

An aerial photograph of the CERN complex in Geneva, Switzerland. The image shows various buildings, including a prominent circular structure in the lower-left quadrant. The text is overlaid on the image.

Optics Measurements, Corrections and Modelling for
High-Performance Storage Rings workshop (OMCM)

The DAΦNE experience

Catia Milardi

June 20th ÷ 22nd 2011, CERN, Geneva

Outline

- *DAΦNE Main Rings*
- *Beam Position diagnostics*
- *Optics Measurements*
- *Closed Orbit steering and correction*
- *σ_y tuning and control*
- *Betatron Coupling analysis and minimization*

Main Rings magnetic layout

General aspects:

- Double ring collider
- Compact magnetic layout
- No periodicity
- All magnetic elements are independently powered
- 4 wigglers in each ring
- 8 dipoles, 4 different kinds each ring, not negligible fringing fields
- Cross talk between e⁺ and e⁻ ring
- Cross talk between e⁻ transfer lines and ring
- Off axis orbit in the low-beta quadrupoles due to horizontal crossing angle at the IP
- Detector solenoidal field (KLOE and FINUDA)
- strongly affecting ring optics

2001 ÷ 2007

- Two 10 meter long IRs common to the colliding beams
- Non-linear terms in the wiggler field almost halved

2007 ÷ 2011

- One IR and complete beam separation 50 cm apart from the IP

Crab-Waist collision scheme

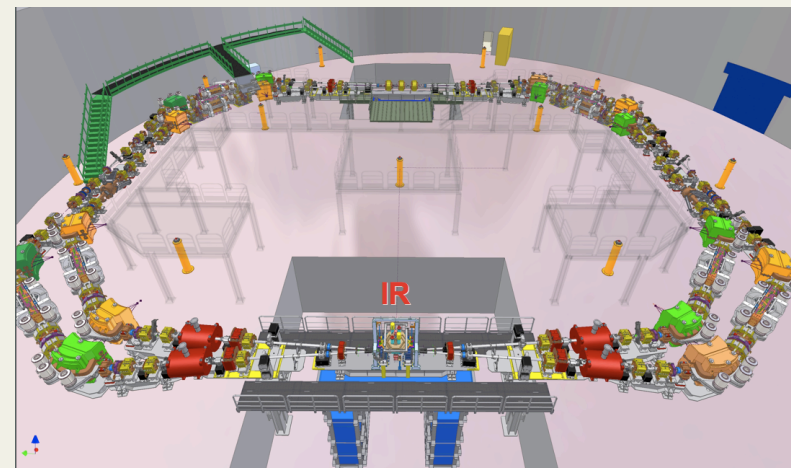
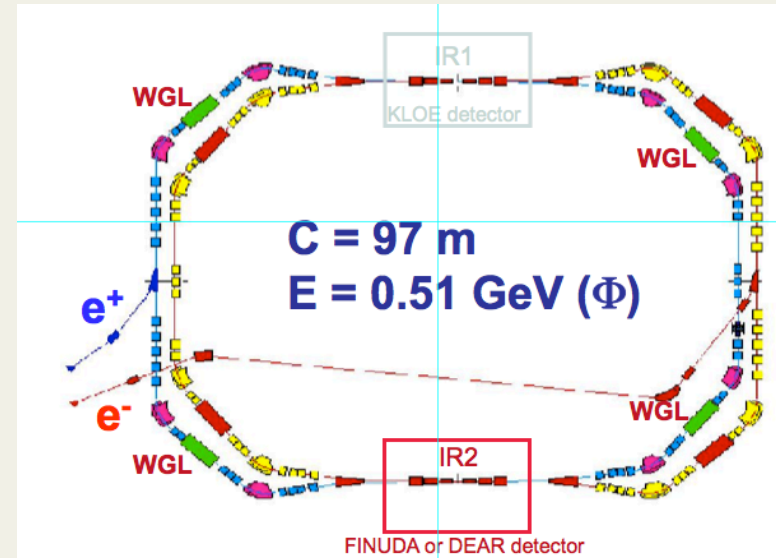

DAΦNE BPMs

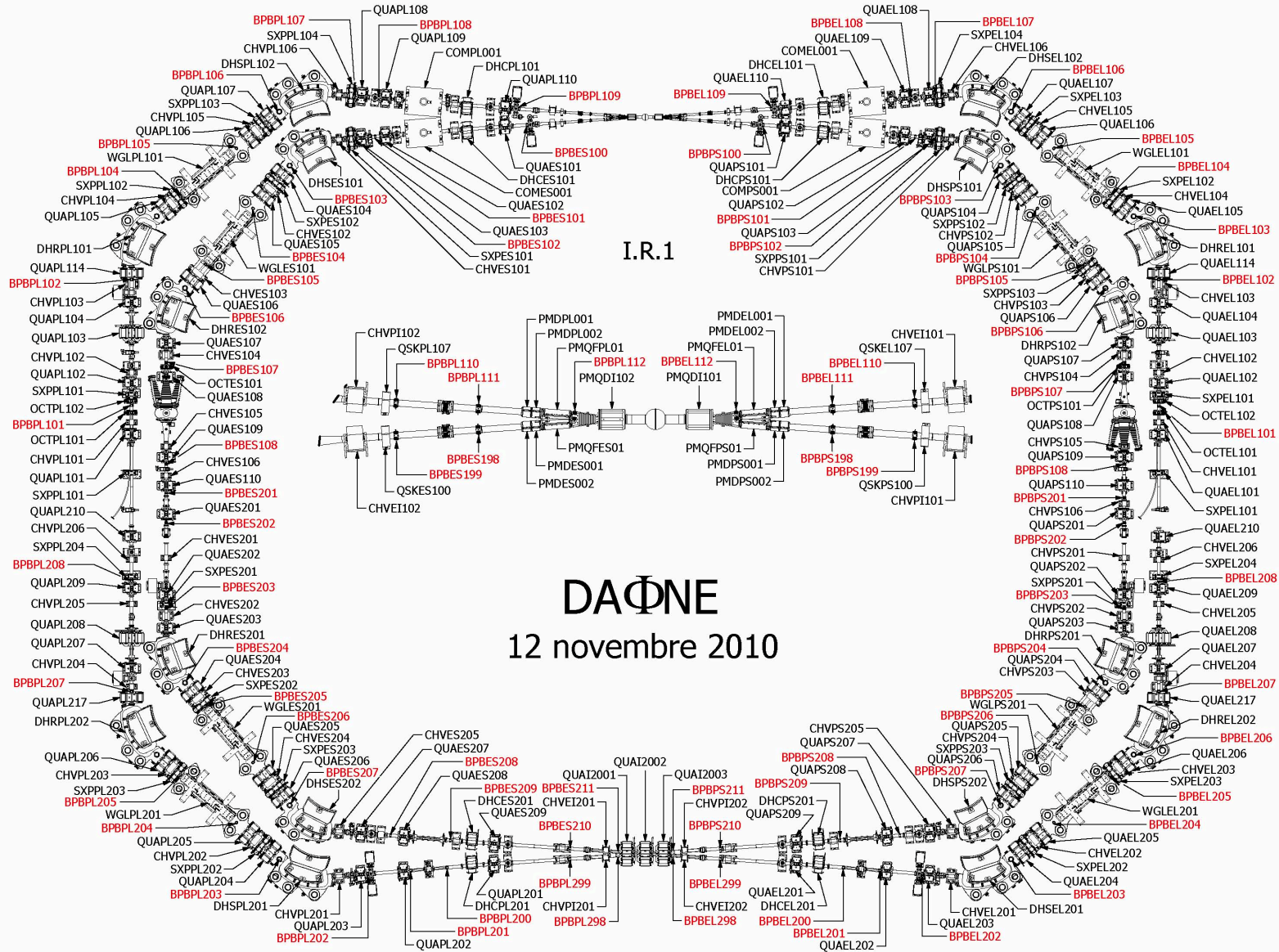

BPM acquisition system

- 120 pickups
- 4 parallel CPUs

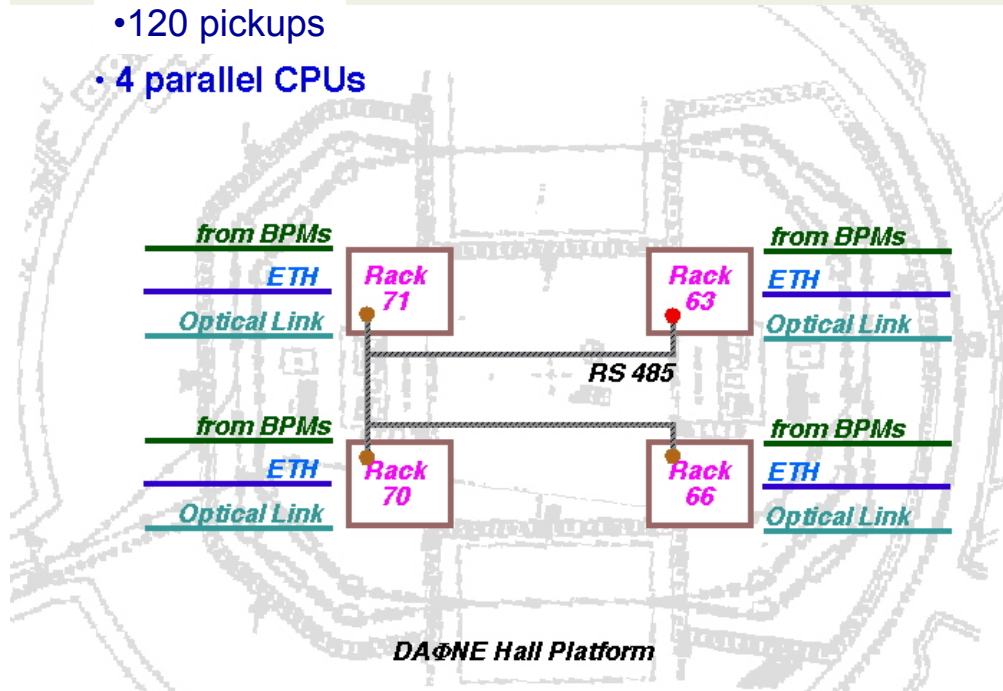

Pickup details:
 Button electrodes 10 mm diameter
 50 Ω matched impedance
 4.2 pF capacitance

Closed Orbit Acquisition Set Up

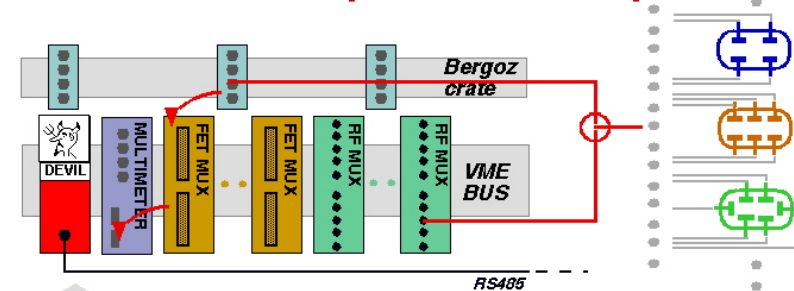

- 5 Orbits each second
- 2000 Orbits stored in the RTDB

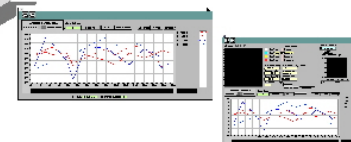

BPM transfer function obtained by:
 Numerical simulation
 Bench measurement
 then used to compensate pickup nonlinearities
 in the range +/- 20 mm

In 2006 4 additional BPMs acquisition systems based on LIBERA modules have been added on each ring



recovery after a major Shutdown	Not yet stored beam <ul style="list-style-type: none"> •Trajectory •Central rev frequency •Tune 	Not available in present system
machine studies	Turn by turn (non linear terms)	Dedicated tracking system
	$\sqrt{\text{Beta}}$ phase advance	Dedicated system
normal operation	Closed orbit	Improved resolution
	Tune	Dedicated system

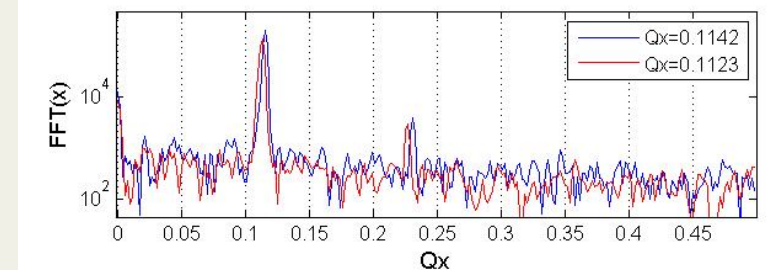
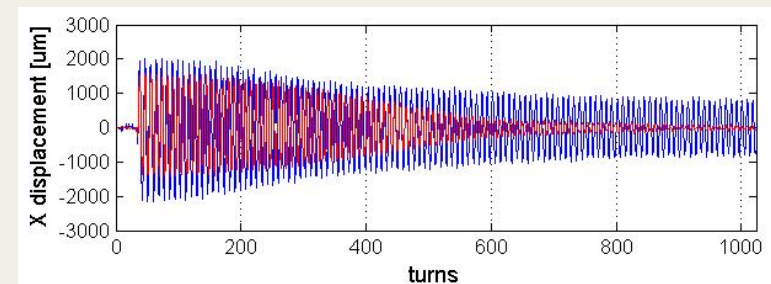

BPM resolution versus beam current

each point is averaged on 100 orbit

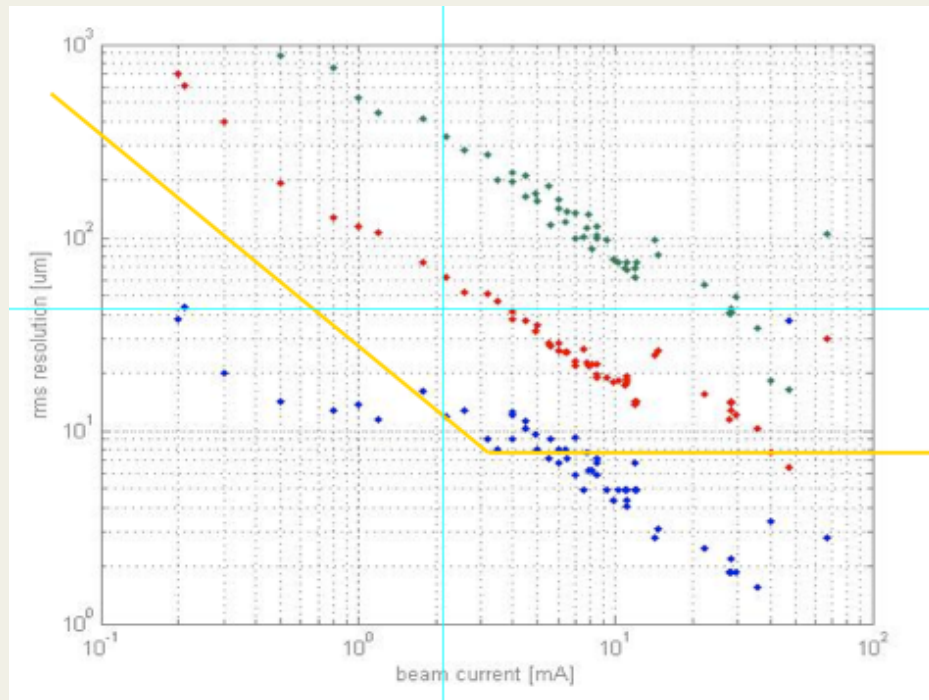

- : Bergoz system resolution
- ◆: libera slow acquisition mode
- ◆: Libera turn by turn mode
- ◆: Libera turn by turn mode (decimated)

For the Bergoz system:

$$\delta x \sim 0.01 \text{ mm} \quad \text{above } \langle I \rangle_{\text{threshold}}$$

3.1 mA (round, diagonal, rect, wiggler)

$$\langle I \rangle_{\text{threshold}} =$$

2.1 mA (dipole, interaction region)

Measured Response Matrix

From Correctors

- orbit correction
- closed bump calculation
- corrector strength reduction
- understand & improve machine linear-model
- dispersion function control
- coupling evaluation

From Quadrupoles

- beam based alignment

$i=1..n_c$ $n_c = 29$ for CHV $n_c = 51$ for QUADS
 $j=1..n_{mon}$ $n_{mon} = 44$

$$z_i = \frac{\sqrt{\beta_i \beta_j}}{2 \sin(\pi \nu)} \cos \nu (|\phi_i - \phi_j| - \pi) \quad z = x, y$$

$$A_{ij} = \frac{\partial z_j}{\partial \vartheta_i} \quad \vartheta_i [mrad] = C_i \frac{I_i [A]}{E [MeV]}$$

$$A_{ij} = \frac{\partial z_j}{\partial I_i}$$

$$A^H = \begin{vmatrix} A^{HH} & 0 \\ 0 & A^{HV} \end{vmatrix}$$

$$A^V = \begin{vmatrix} 0 & A^{VV} \\ A^{VH} & 0 \end{vmatrix}$$

Closed Orbit correction & Beam Steering by measured Response Matrix

- Global Orbit Correction

$$\bar{z} = A\Delta\bar{I}$$

- Corrector strength reduction

$$(\bar{z} + A\bar{I}_0) = A\bar{I}$$

- Best Corrector useful in identifying power supply faults & drifts

$$I_j = \frac{\sum_i z_i A_{ij}}{\sum_i A_{ij}^2}$$

Equations are least square solved by Singular Value Decomposition

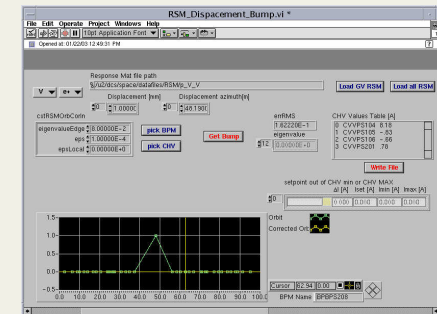

These algorithms are unaffected from:

- model imperfection
- corrector calibration constant
- offset in BPMs alignment
- overall offset in orbit readout

Best Orbit at DAΦNE

Closed Orbit Correction and steering magnet strength minimization to:

- Point out errors in the magnetic layout
- Reduce non-linear contributions to the beam optics ($\varepsilon_x, \alpha_c, \tau$)
- Keep beam dispersion under control
- Minimize transverse coupling (ε_y, κ)
- reduce background hitting the experimental detector and ameliorate scrapers efficiency

Orbit can be made as small as desired, however the most suitable value for operation is obtained iteratively by global, local correction and steering magnet strength minimization.

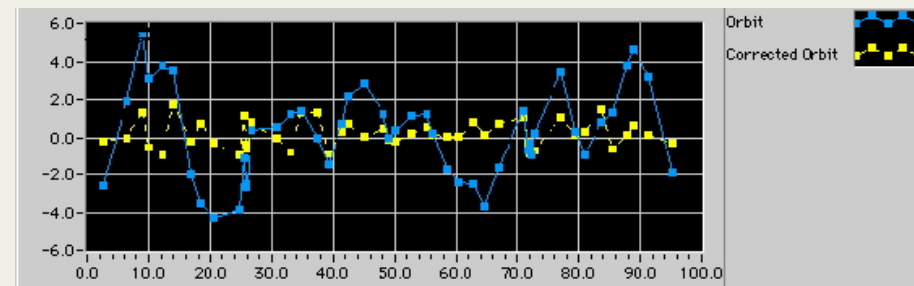

$$-0.5 \text{ [mm]} < R_h^{\text{theoretical}} < 1.8 \text{ [mm]}$$

azimuth [m]

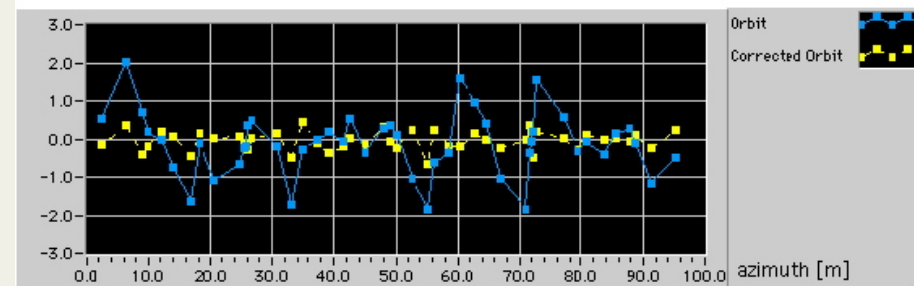

$$-0.5 \text{ [mm]} < R_v^{\text{theoretical}} < 0.5 \text{ [mm]}$$

azimuth [m]

Bare orbit minimization by element alignment

$$z_{bare} = z_{beam} - z_{\Sigma Steers}$$

- A large bare orbit indicates always alignment problems
- Misalignment errors are identified by fitting the measured bare orbit with the machine model

In the example:

Bare orbit has been reduced in both rings by repositioning the outer electromagnetic QUADS in the FINUDA IR

After alignment:

- strengths of the steering magnets adjacent to the IR2 section are considerably reduced
- bare orbit is significantly reduced and is comparable in the two rings

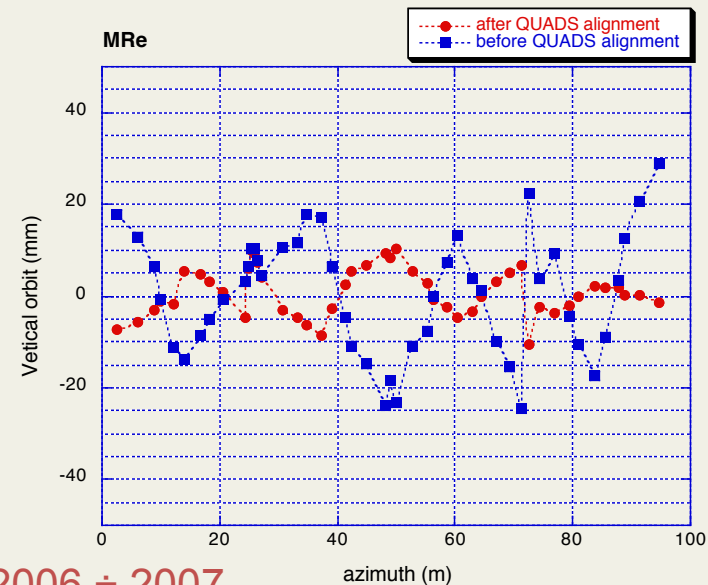
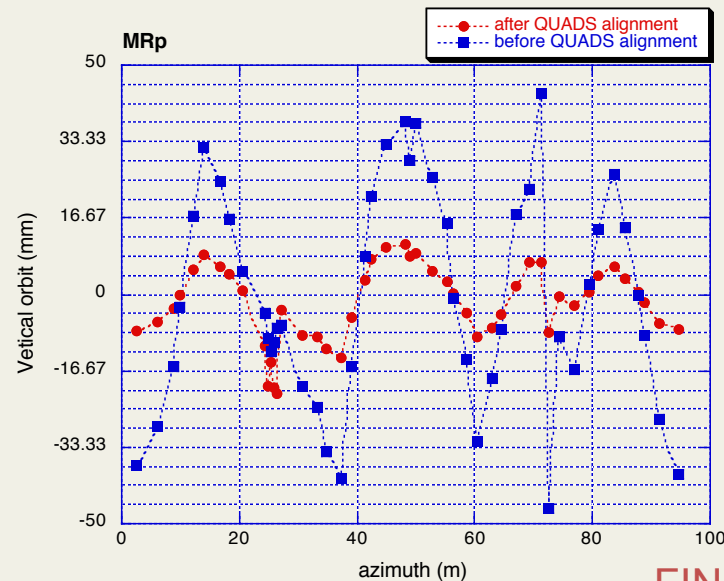

FINUDA run 2006 ÷ 2007

Twiss function measurement & ring optics

β measurements performed by:

- varying the quadrupole strength (**42 QUADS per ring**)
- Correcting the closed orbit variation, if any
- the β value precision depends on the accuracy of the tune measurement, possible systematic errors in the quadrupoles calibration are neglected

Optics measurements ($\beta_1, \beta_2, \nu_1, \nu_2, \eta_x, \eta_y, \xi_x, \xi_y$) are used for model optimization

The model is used for:

- optics computation
- measurements analysis
- lifetime computation
- dynamic aperture studies
- background, beam-beam and e-cloud simulations

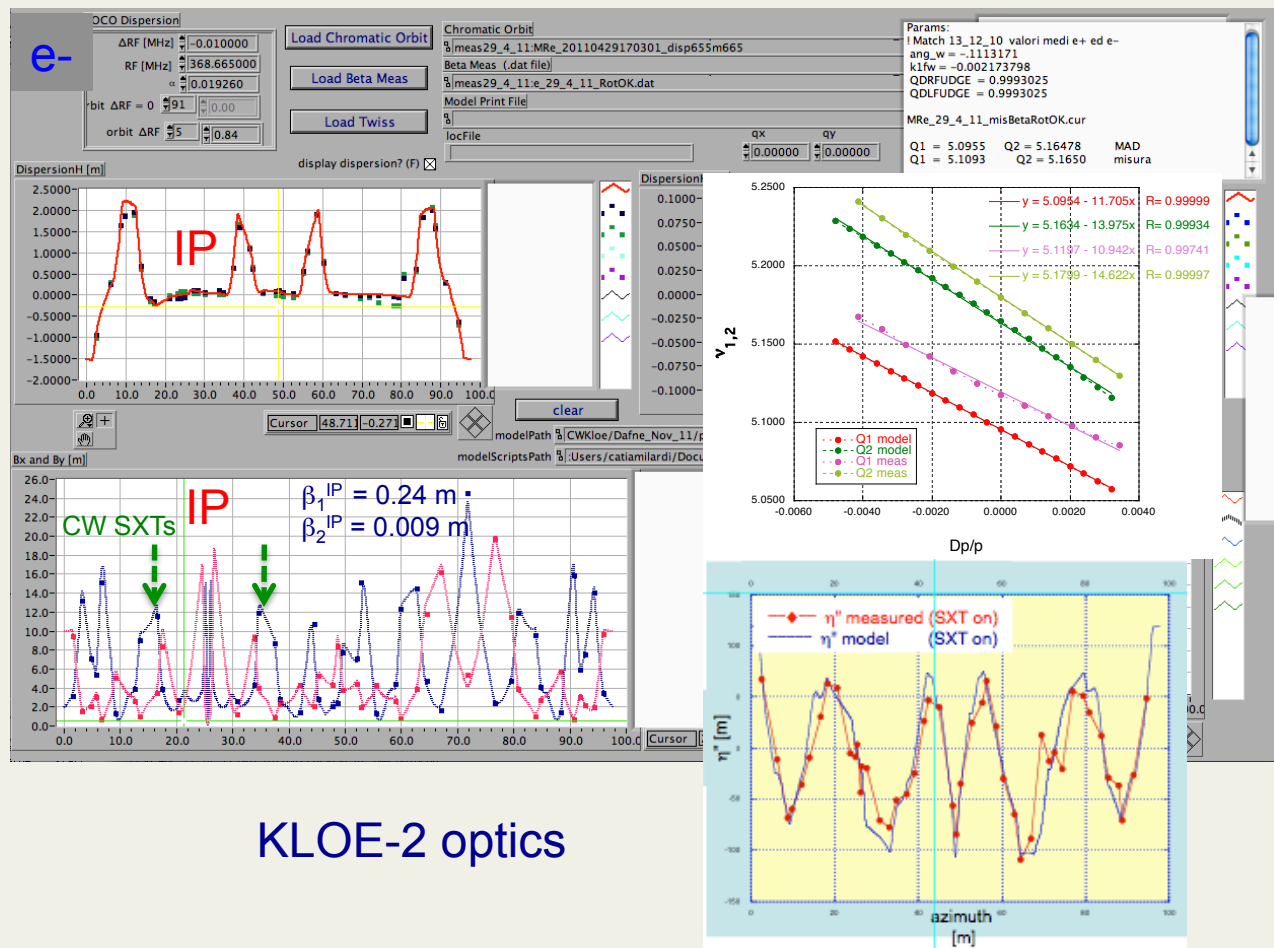

KLOE-2 optics

β -function evaluation by measured Response Matrix

$$R_{ij} = \frac{\sqrt{\beta_i \beta_j}}{2 \sin(\pi \nu)} \cos \nu (|\phi_i - \phi_j| - \pi)$$

$$i=1 \dots n_{BPM} = 44$$

$$j=1 \dots n_{CHV} = 29$$

$$n_{BPM} + n_{CHV} = 73$$

- β can be evaluated in automatic and fast way at all BPMs and CHVs
- The equation system given by the R matrix is solved iteratively by using SVD numerical technique
- The procedure starts from an initial set of $(\beta_i \phi_i)$ and $(\beta_j \phi_j)$ and stops when ν converges to the measured value
- Ambiguity in the β determination can be avoided by imposing equal β at a couple of adjacent BPM and CHV

β_x compared with the MAD model (e⁻ ring)

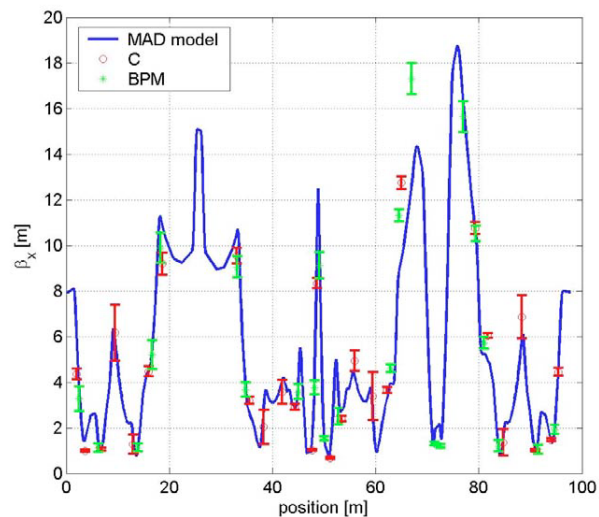

β_y compared with the MAD model (e⁻ ring)

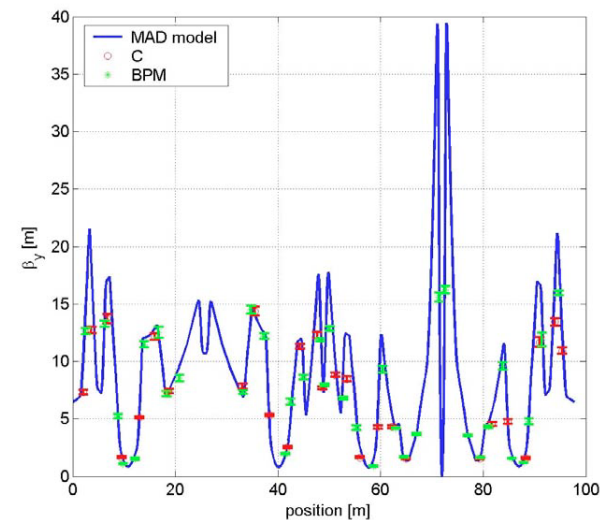

DEAR run (2002)

Original DEAR IR:

$$IR^{DEAR} (Q_F Q_D Q_F) \quad \beta_x^* = 4.4 \text{ m} \quad \beta_y^* = 0.04 \text{ m}$$

New DEAR low-beta

$$IR^{DEAR} (Q_D Q_F)$$

$$\beta_x^* = 1.7 \text{ [m]} \quad \beta_y^* = 0.03 \text{ [m]}$$

$$\alpha_x^* = 25 \rightarrow 29 \text{ mrd}$$

$$\beta_x^{PC} \text{ reduced by 50\%}$$

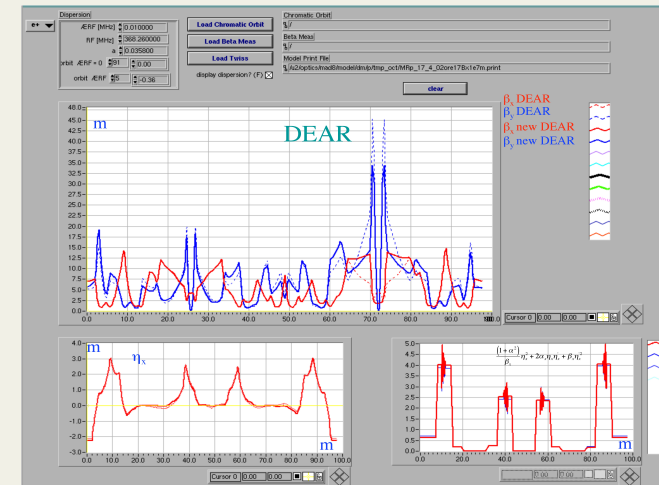

100 contiguous bunches in collision for the first time !

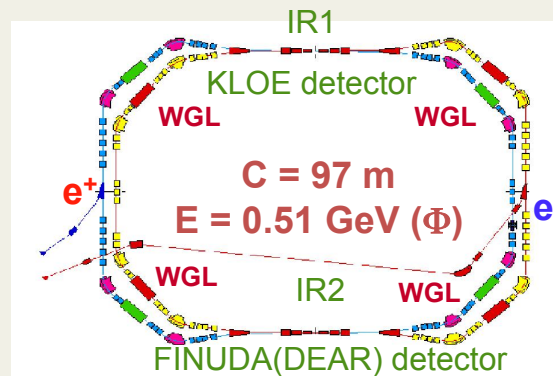

The KLOE IR is going to be modified according the DEAR one

Parasitic Crossings in the DAFNE IR1 (KLOE run 2005)

In the original DAFNE IRs the beams experienced 24 Long Range Beam Beam interactions

computed orbit deflection due to 24 LRBB interactions for the positron bunch colliding against 10 mA electron bunches.

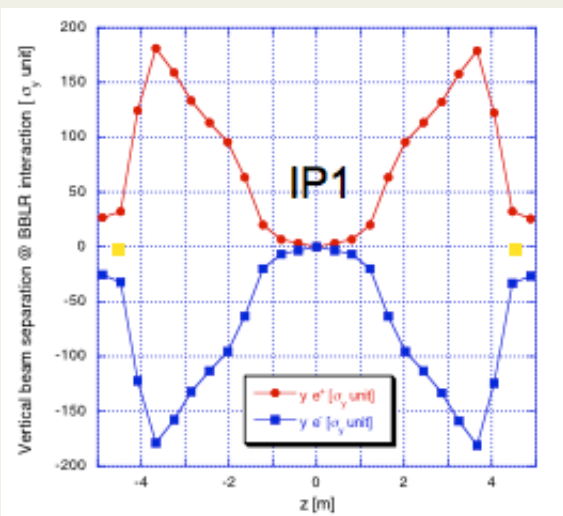
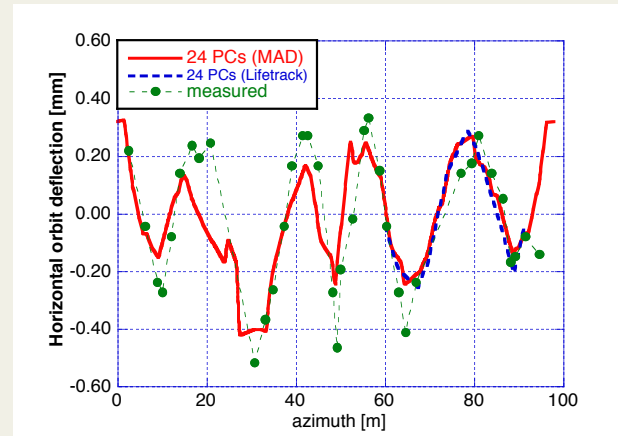
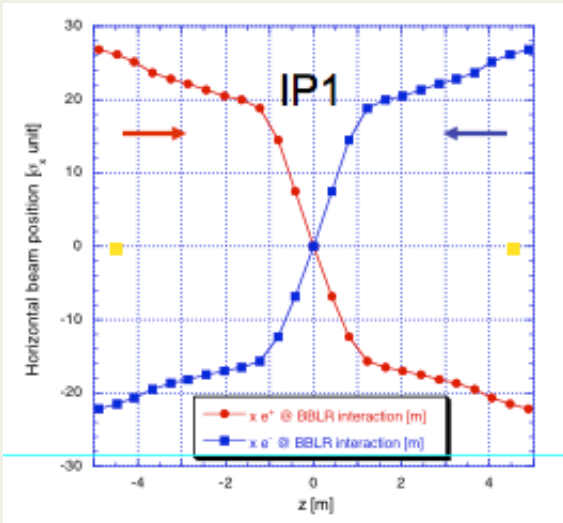

LIFETRACK simulation

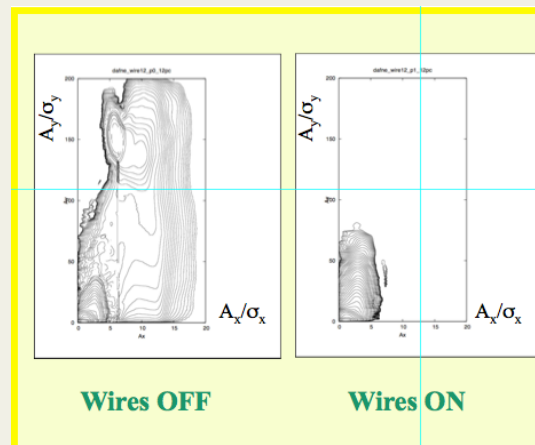

- 2 current carrying windings (wires) installed at both ends of the KLOE interaction region (IR)
- It's necessary to separate the beams as close as possible after the IP

1 IP + 2 nearest PC + C₁₁...

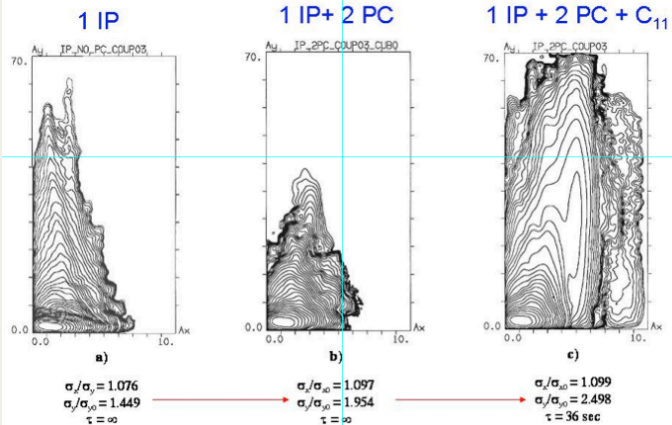

Working point & nonlinearities compensation tuning during II FINUDA run (Nov 06 ÷ May 07)

$$v_x^- = 086 \quad v_x^+ = .1090$$

$$v_y^- = .1560 \quad v_y^+ = .1910.$$



$$v_x^- = .076 \quad v_x^+ = .096$$

$$v_y^- = .14 \quad v_y^+ = .168$$

- Improve peak luminosity
- limit beam-beam blow-up at high currents

During e⁻ beam injection

$$\Delta v_{x,y}^+ = 0.0005 \div 0.0015$$

$$\Delta k_3^+ = 5. \div 15 \text{ A}$$

double the e⁺ beam lifetime

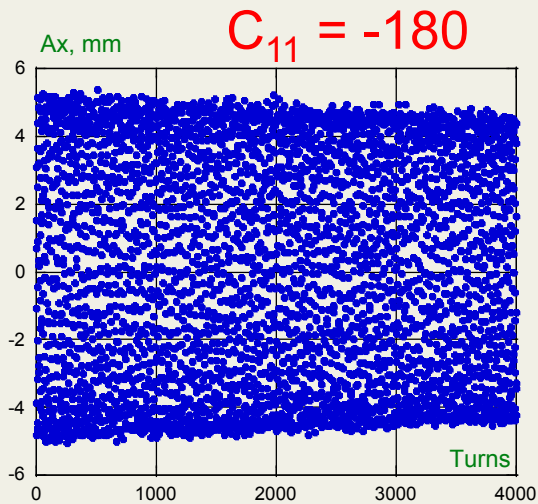
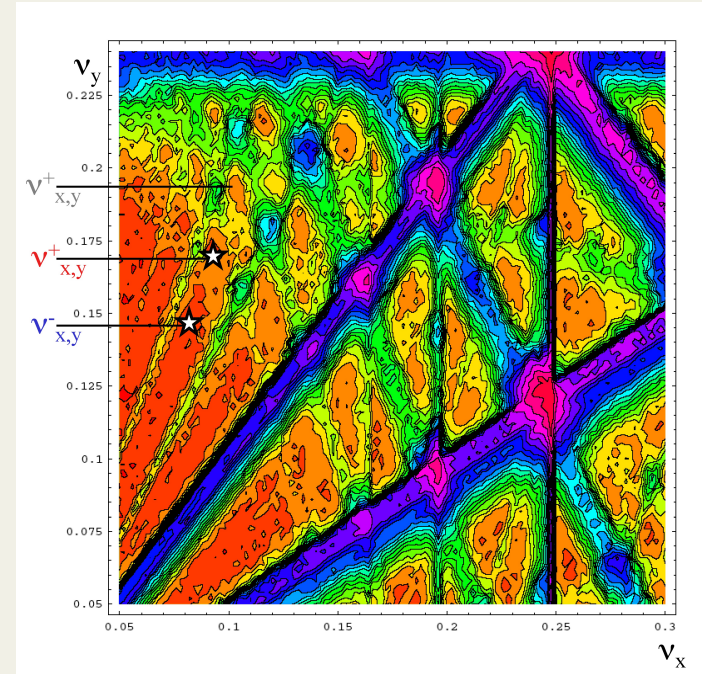

Octupole ON (I = 43 A)

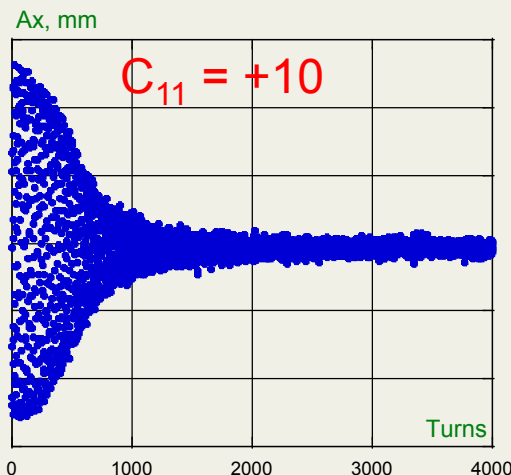

Octupole OFF

Octupole variation affects:

- C₁₁
- dynamic aperture
- ξ''

DAΦNE optics with negative momentum compaction

(KLOE run 2004÷2006)

- Bunch lengthening with current is considerably reduced
- Head-tail instability occurs for $\xi_{x,y} > 0$, the ring can be operated without or with very weak sextupoles
- Beam-beam is in general less harmful and the beam is in general more stable

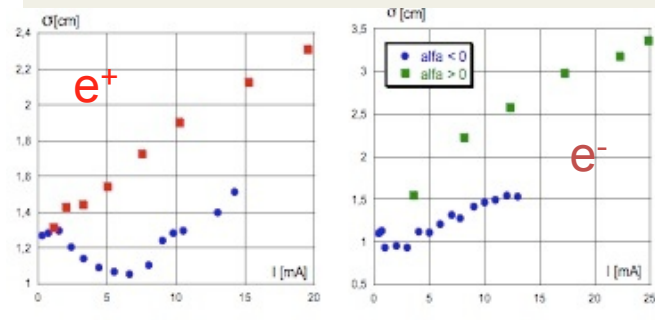
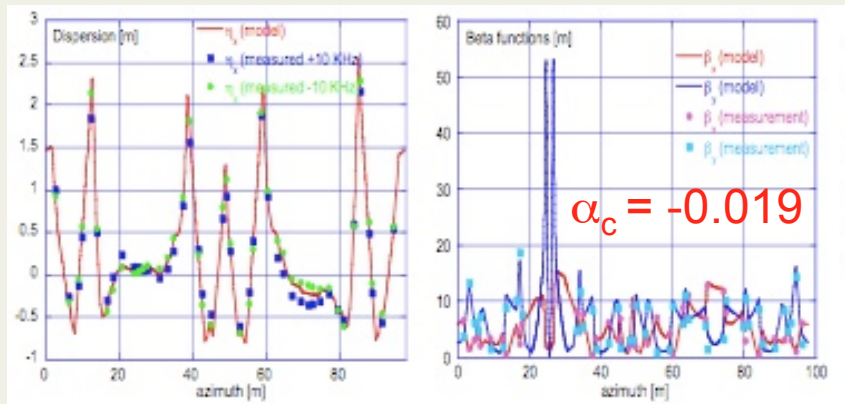

Collision $\alpha_c < 0$

- $\mathcal{L}_{\text{peak}} \sim 2.5 \cdot 10^{31} \text{ cm}^{-2} \text{ s}^{-1}$
- $I^- \sim 0.3 \text{ A}$ $n_b = 100$
- $I^+ \sim 0.3 \text{ A}$

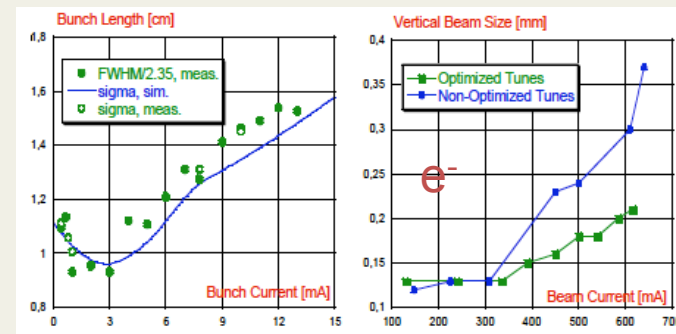
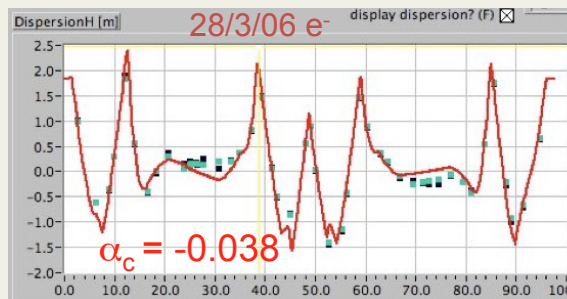

A strong correlation has been observed between the longitudinal microwave instability and the vertical size blow-up

e- Vertical Size Blow-up with large α_c

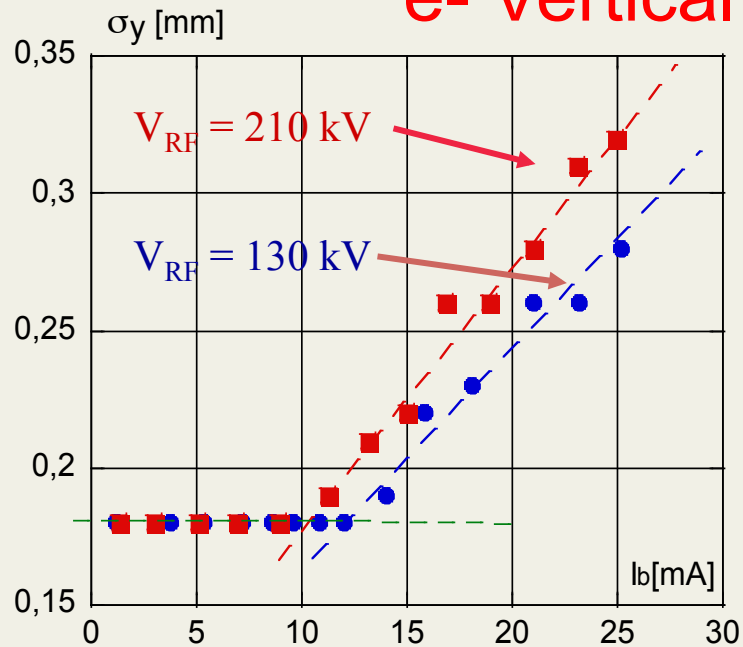

Data from KLOE run Apr. 05

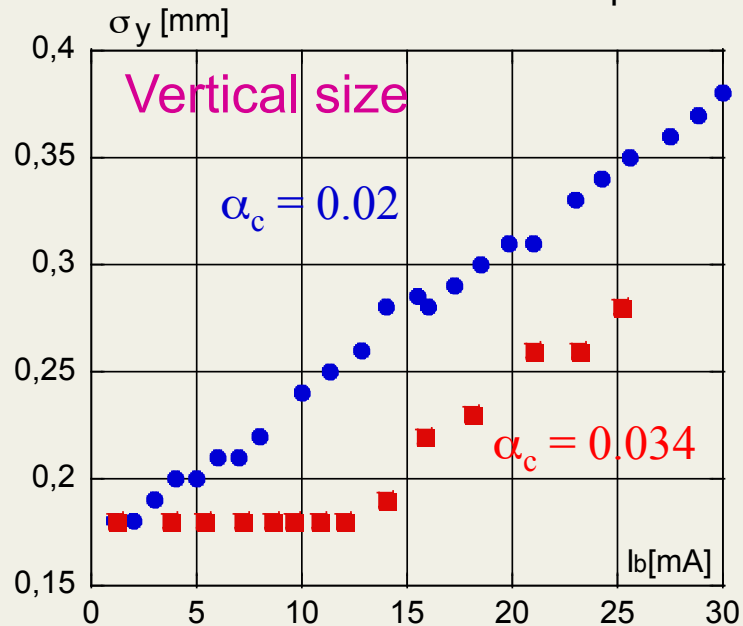

- Single bunch (beam) effect
- It is correlated with the longitudinal microwave instability threshold:

$$\text{Threshold scales} \approx \sqrt{\frac{1}{V_{RF}}} \propto 1.27$$
- It is relevant for the e- ring having higher coupling impedance
- The threshold is higher for higher momentum compaction

It is necessary to reduce the ring impedance

σ_y tuning

High luminosity cannot be achieved without a careful control of the σ_y parameter

$$\sigma_y = \sqrt{\varepsilon_y \beta_y + \eta_y^2 \sigma_p^2} \quad \varepsilon_y = \varepsilon_0 \frac{\kappa}{1 + \kappa}$$

Dominant source of σ_y are:

- large vertical orbit
- vertical dispersion
- transverse betatron coupling due to:
 - experimental solenoid
 - roll errors in quadrupoles
 - vertical orbit distortion in sextupoles
- vacuum chamber impedance

Vertical Dispersion minimization

Correcting orbit and dispersion at the same time by using orbit and dispersion dependence on the **steering magnets** and on the **skew quadrupoles** current

$$\bar{y} = K \Delta \bar{I}_s$$

BPM $i=1 \dots n_m = 44$
 Corrector $j=1 \dots n_c = 29$
 Skew Quadrupole $N_s = 10$

$$y = \begin{pmatrix} \frac{\partial y_1}{\partial C_{h1}} \\ \dots \\ \frac{\partial y_{Nm}}{\partial C_{h1}} \\ \dots \\ \frac{\partial y_1}{\partial C_{hNc}} \\ \dots \\ \frac{\partial y_{Nm}}{\partial C_{hNc}} \\ \frac{\partial y_1}{\partial f_{RF}} \\ \dots \\ \frac{\partial y_{Nm}}{\partial f_{RF}} \end{pmatrix}$$

$$K = \begin{pmatrix} \frac{\partial y_1}{\partial C_{h1} \partial S_1} \dots \frac{\partial y_1}{\partial C_{h1} \partial S_{Ns}} \\ \dots \\ \frac{\partial y_{Nm}}{\partial C_{h1} \partial S_1} \dots \frac{\partial y_{Nm}}{\partial C_{h1} \partial S_{Ns}} \\ \dots \\ \frac{\partial y_1}{\partial C_{hNc} \partial S_1} \dots \frac{\partial y_1}{\partial C_{hNc} \partial S_{Ns}} \\ \dots \\ \frac{\partial y_{Nm}}{\partial C_{hNc} \partial S_1} \dots \frac{\partial y_{Nm}}{\partial C_{hNc} \partial S_{Ns}} \\ \frac{\partial y_1}{\partial f_{RF} \partial S_1} \dots \frac{\partial y_{Nm}}{\partial f_{RF} \partial S_{Ns}} \\ \dots \\ \frac{\partial y_{Nm}}{\partial f_{RF} \partial S_1} \dots \frac{\partial y_{Nm}}{\partial f_{RF} \partial S_{Ns}} \end{pmatrix}$$

$(N_m * N_c) + N_m$

Vertical Dispersion minimization

Correcting orbit and dispersion at the same time using orbit and dispersion dependence on the steering magnets

$$\bar{u} = D\Delta\bar{I}$$

$$i=1 \dots n_{mon} = 44$$

$$j=1 \dots n_{CHV} = 29$$

$$u = \begin{pmatrix} y_1 \\ \cdot \\ y_{n_{mon}} \\ \eta_1 \\ \cdot \\ \eta_{n_{mon}} \end{pmatrix} = \begin{matrix} 2 * n_{mon} \\ D = \cdot \end{matrix} \begin{pmatrix} \cdot & \cdot & \cdot & \cdot \\ \cdot & \cdot & \frac{\partial y_i}{\partial I_j} & \cdot \\ \cdot & \cdot & \cdot & \cdot \\ \cdot & \cdot & \frac{\partial \eta_i}{\partial I_j} & \cdot \\ \cdot & \cdot & \cdot & \cdot \end{pmatrix} \begin{matrix} n_{kick} \\ \cdot \\ \cdot \\ \cdot \\ \cdot \end{matrix}$$

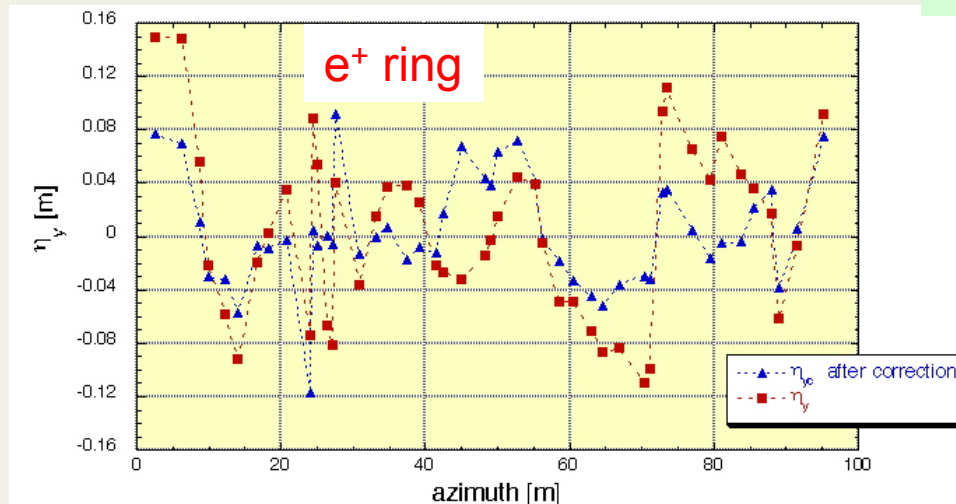

$$(\eta_y)_{rsm} = 0.0647 \text{ m}$$

$$(\eta_{yc})_{rsm} = 0.0411 \text{ m}$$

$$\Delta(\eta_y)_{rsm} = -36\%$$

$$R^+ = 0.093$$

$$R^+_{\eta_c} = 0.081 \text{ measured @ SLM}$$

$$\Delta R^+ = -13\%$$

$$\frac{\partial \eta_i}{\partial I_j} = a \frac{\partial y_i}{\partial I_j}$$

Vertical Dispersion control & Main rings tuning

Closed Orbit Correction and steering magnet strength minimization help in:

- Finding errors in the magnetic layout
- Reducing the effect of non-linear contributions to the beam optics

Sextupoles alignment to avoid unexpected contribution to linear optics

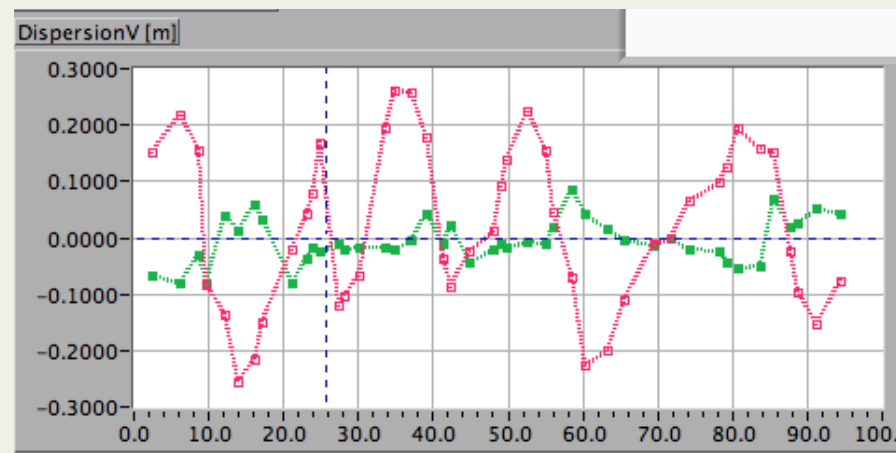
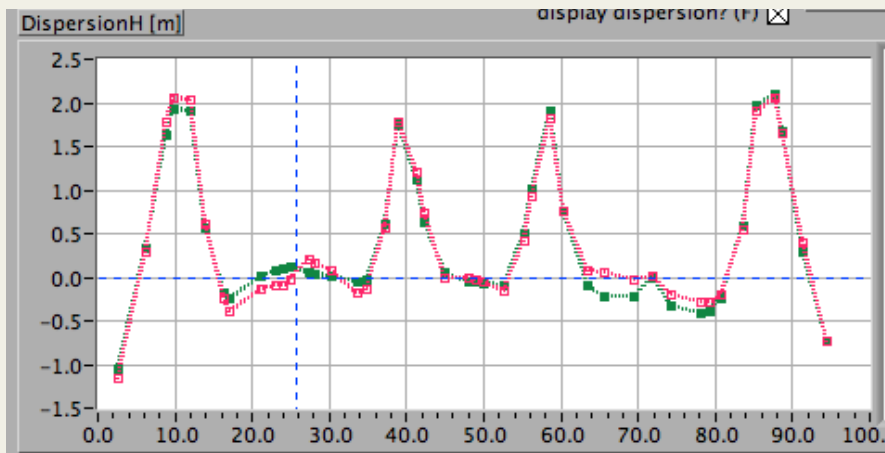

Dispersion evolution before (red MRp_29_11_2010) and after (green MRp_23_5_2011) closed orbit optimization and sextupole alignment

Wiggler measurement

The non-linear components of the WIGEL101 field are evaluated by measuring the beam tune shift dependence on the horizontal displacement bump at its place after switching off the sextupoles in that sector

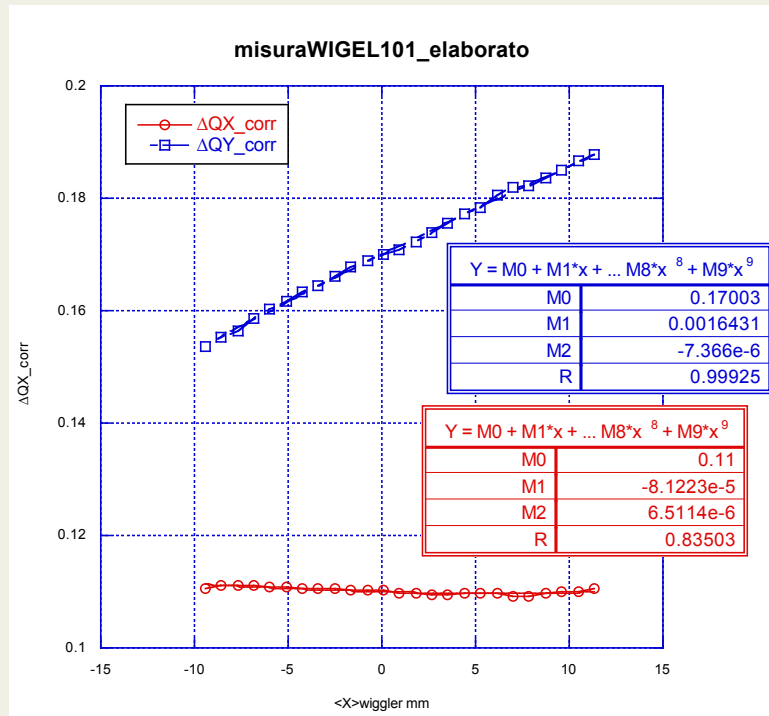
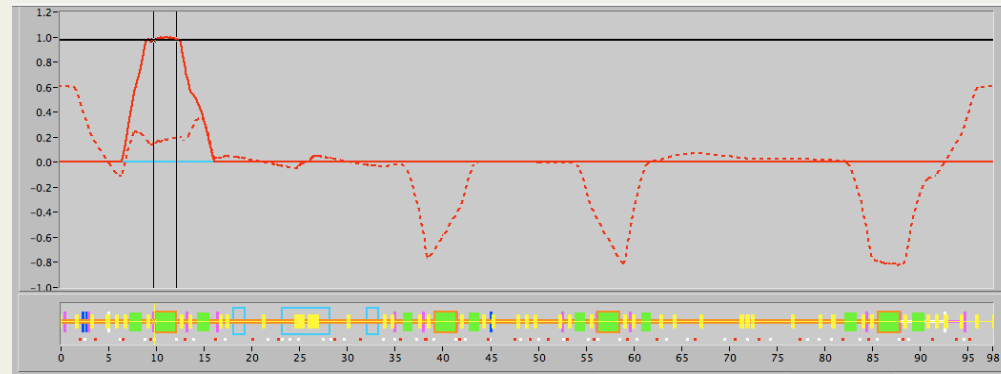

- Δv_x and Δv_y exhibit an evident linear behaviour excluding the presence of any octupole-like or higher component in the magnetic field
- A small sextupole-like dependence is observed in Δv_y only, probably originated in the nearby dipoles included in the bump

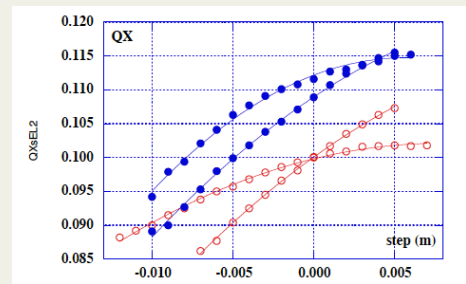

Figure 8: Measured horizontal betatron tune versus beam displacement in 4 wigglers

Published in 2004

K ³ [m ⁻³]	Year
800	2001
360	2004
0	2011

κ correction @ DAΦNE

FINUDA IR

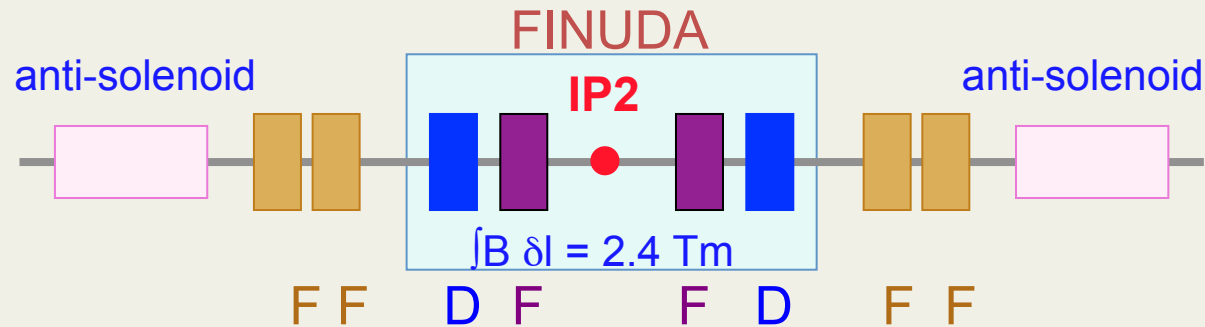

- $\int B \delta l = 2.4 \text{ Tm}$
- 2 superconductive compensator solenoids •
- 4 permanent magnet QUADs • •
- 4 electromagnetic QUADs •
- Independent QUADs rotation

- KLOE solenoids off (IP_1)
- $\epsilon_x = .34 \mu$
 $\Delta x \sim 13 \sigma_x$ @ 1st par. cros.
 100 consecutive bunches (1 bucket 2.7 ns)
- low- β @ FINUDA IP_2
 $\beta_x^* = 2.33 \text{ m}$
 $\beta_y^* = .024 \text{ m}$
 $\theta_x = .021 \text{ rad}$

The main part of residual transverse coupling has been corrected by rotating the QUADs in IR2

Fine tuning is performed using skew QUADs

Betatron coupling correction

- local correction
 - by minimizing the coupling term of the measured Response Matrix by the IRs QUAD rotations $\Delta\phi_j$ $j=1..8$

$$M\Delta\phi = C^{meas}$$

$$M^{mod} = \begin{matrix} \frac{\partial y_{m_1}}{\partial k_{h_1} \partial \phi_1} & \cdot & \cdot & \cdot & \frac{\partial y_{m_1}}{\partial k_{h_1} \partial \phi_8} \\ \cdot & \cdot & \cdot & \cdot & \cdot \\ \cdot & \cdot & \cdot & \cdot & \cdot \\ \frac{\partial y_{m_{nBPM}}}{\partial k_{h_n kick} \partial \phi_1} & \cdot & \cdot & \cdot & \frac{\partial y_{m_{nBPM}}}{\partial k_{h_n kick} \partial \phi_8} \\ \frac{\partial x_{m_1}}{\partial k_{v_1} \partial \phi_1} & & & & \frac{\partial x_{m_1}}{\partial k_{v_1} \partial \phi_8} \\ \cdot & & & & \cdot \\ \cdot & & & & \cdot \\ \frac{\partial x_{m_{nBPM}}}{\partial k_{v_n kick} \partial \phi_1} & & & & \frac{\partial x_{m_{nBPM}}}{\partial k_{v_n kick} \partial \phi_8} \end{matrix}$$

$$C^{meas} = \begin{matrix} \frac{\partial y_{m_1}}{\partial k_{h_1}} \\ \cdot \\ \cdot \\ \frac{\partial y_{m_{nBPM}}}{\partial k_{h_n kick}} \\ \frac{\partial x_{m_1}}{\partial k_{v_1}} \\ \cdot \\ \cdot \\ \frac{\partial x_{m_{nBPM}}}{\partial k_{v_n kick}} \end{matrix}$$

- linear system solved by SVD
- after few iteration 40% reduction in rms (C^{meas})

- global correction by SKEW QUADS

σ_y (KEK) = .3 mm
 σ_y (PEP) > .4 mm

$\kappa = .3\%$

measured by

- beam - beam scan
- beam aspect ratio @ SLM

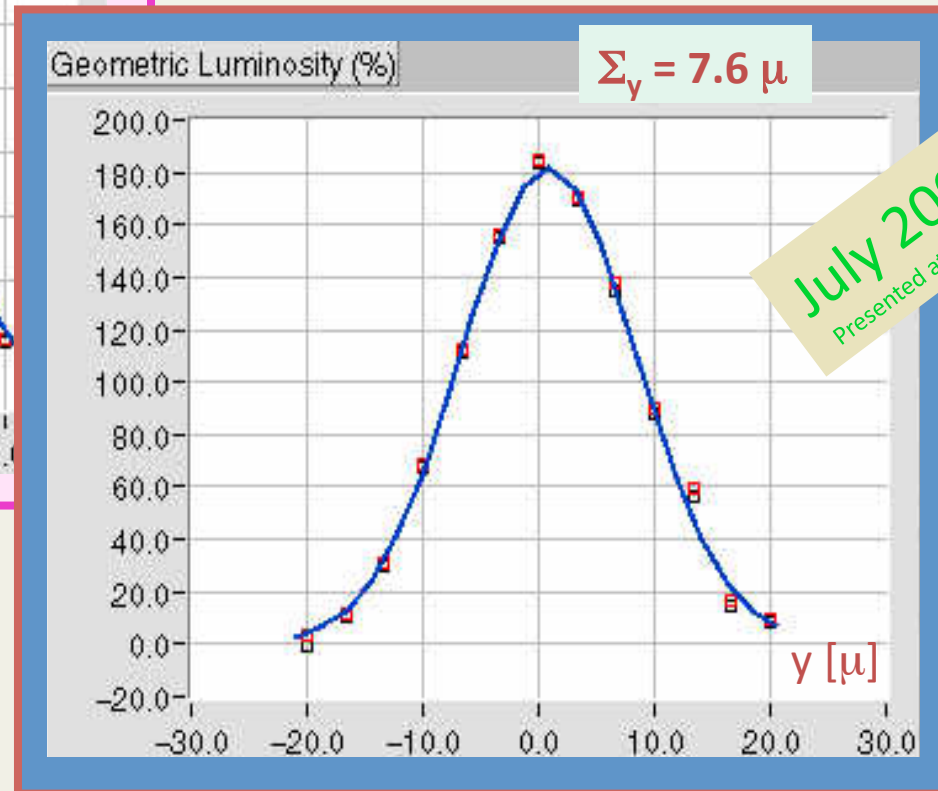
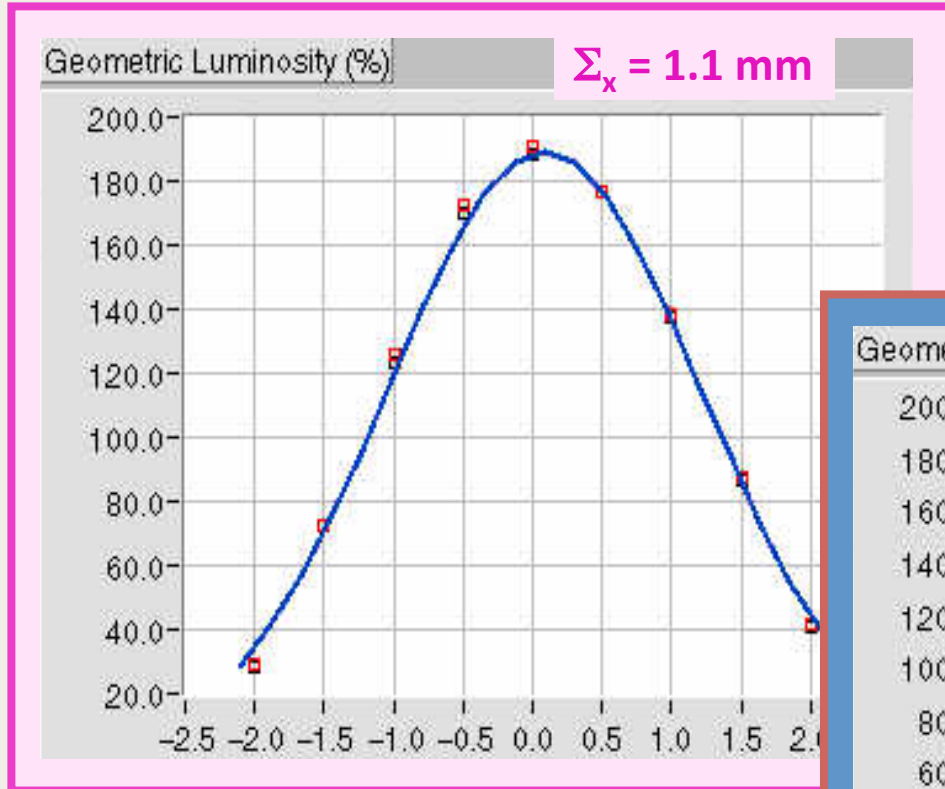

July 2006
 Presented at EPAC04

$$\Sigma_{x,y} = \sqrt{(\sigma_{x,y}^{+2} + \sigma_{x,y}^{-2})}$$

The new KLOE-2 IR with the *Crab-Waist* collision scheme

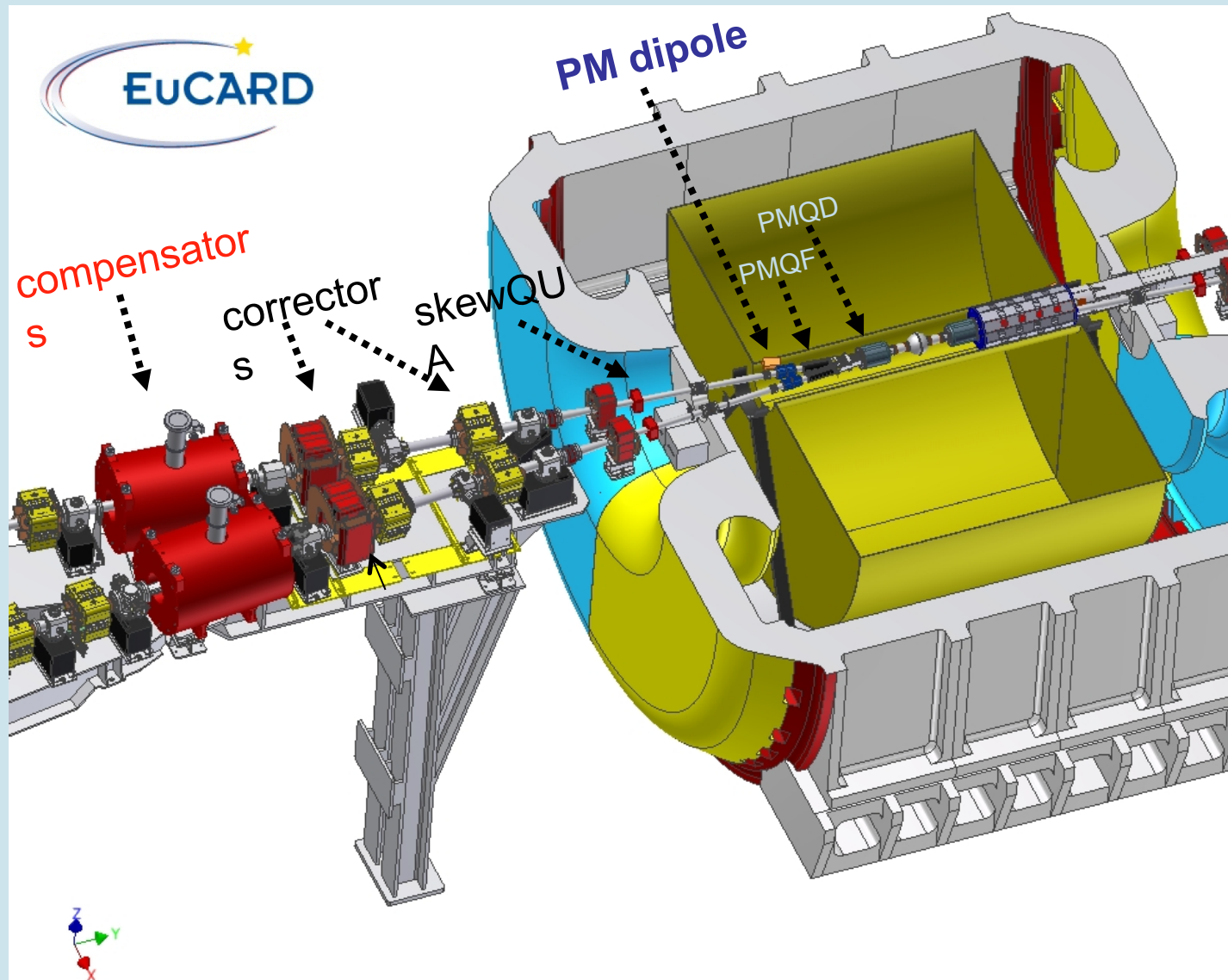

Coupling correction

• $\int_{KLOE} B \cdot dl$ canceled by 2 anti-solenoids for each beam

$$\int_{KLOE} B \cdot dl = 2.048 \quad [Tm] \quad \rightarrow \quad I_{KLOE} = 2300. [A]$$

$$\int_{comp} B \cdot dl = \pm 1.024 \quad [Tm] \quad \rightarrow \quad I_{comp} = 86.7 [A]$$

To achieve coupling compensation also for off-energy particles

Fixed QUAD rotations

K is expected to be lower than for KLOE past

$$K_{KLOE1} = 0.2 \div 0.3 \%$$

	Z from the IP [m]	Quadrupole rotation angles [deg] <i>Anti-solenoid current [A]</i>
PMQDI101	0.415	0.0
PMQFPS01	0.963	-4.48
QSKPS100	2.634	used for fine tuning
QUAPS101	4.438	-13.73
QUAPS102	8.219	0.906
QUAPS103	8.981	-0.906
COMPS001	6.963	72.48 (optimal value 86.7)

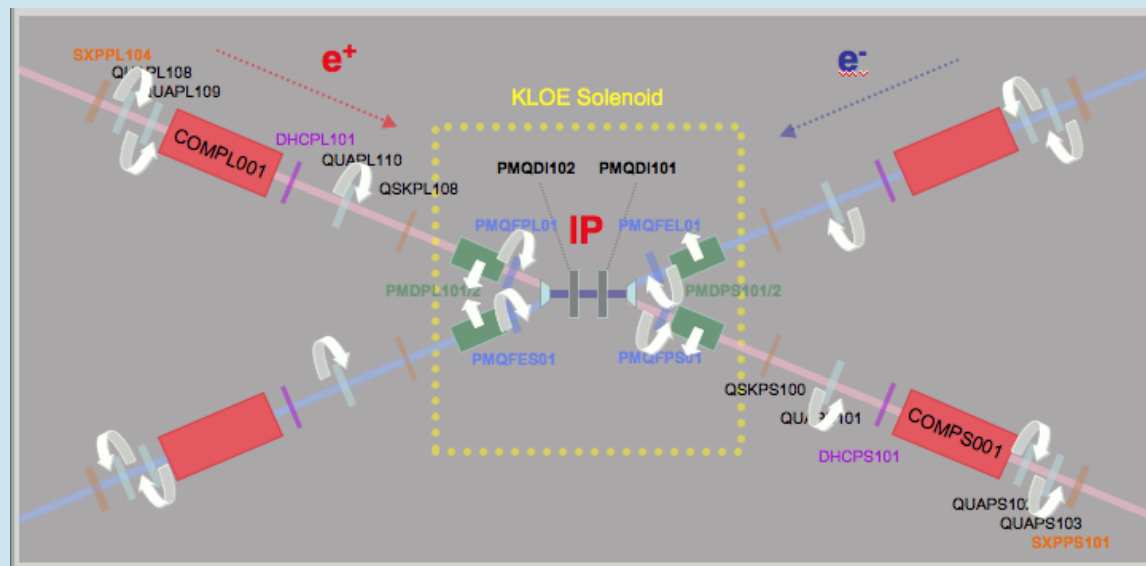

Betatron coupling analysis

- Transverse beam dynamics in presence of coupling is described by two normal modes
- normal modes when projected on the x-y plane are represented by an ellipse with a given eccentricity and tilt
- In this graphs the normal mode tilts computed from the ring model are compared with the corresponding values obtained from the measured steering magnet response matrices

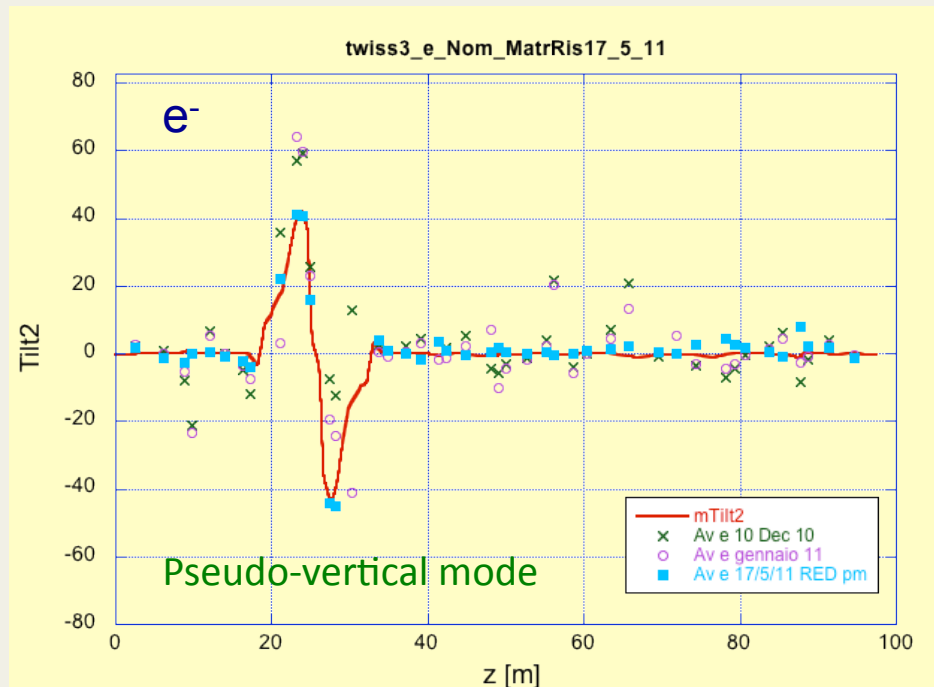
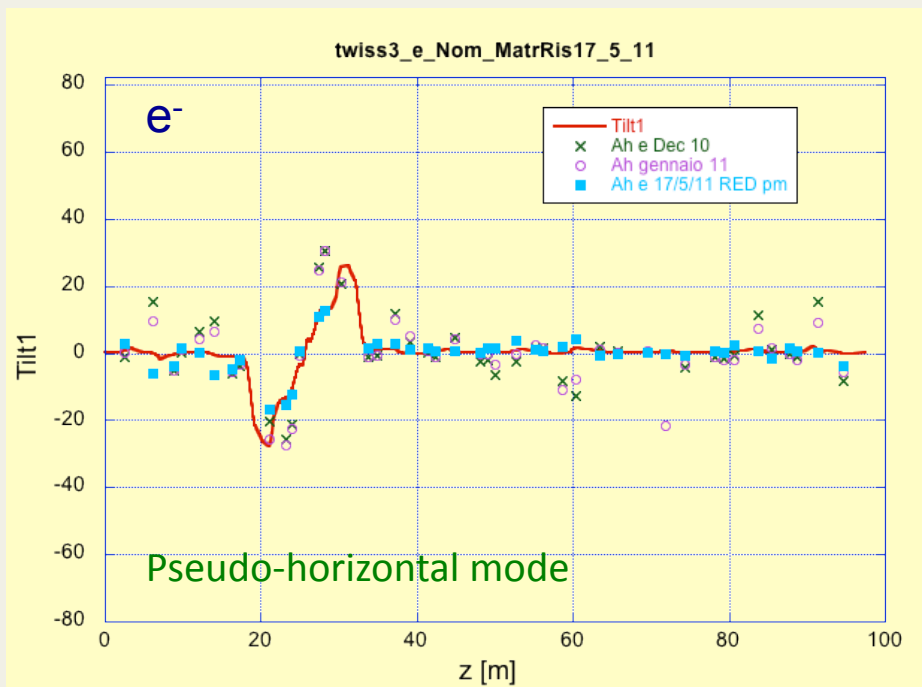
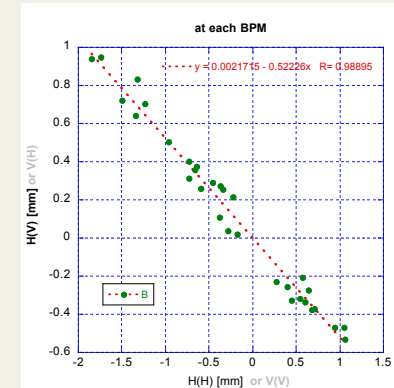

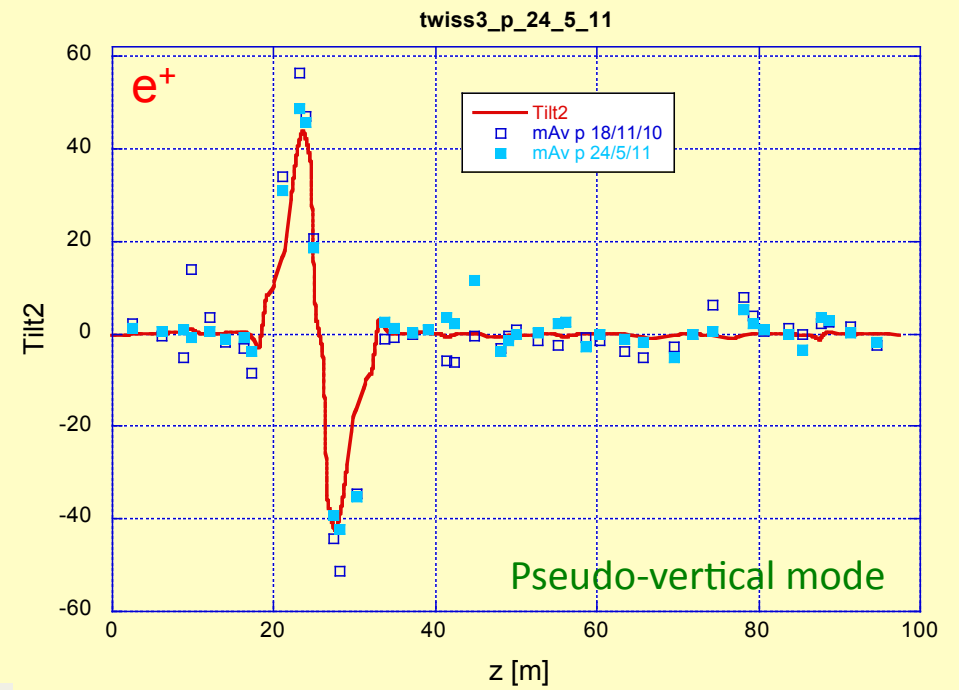
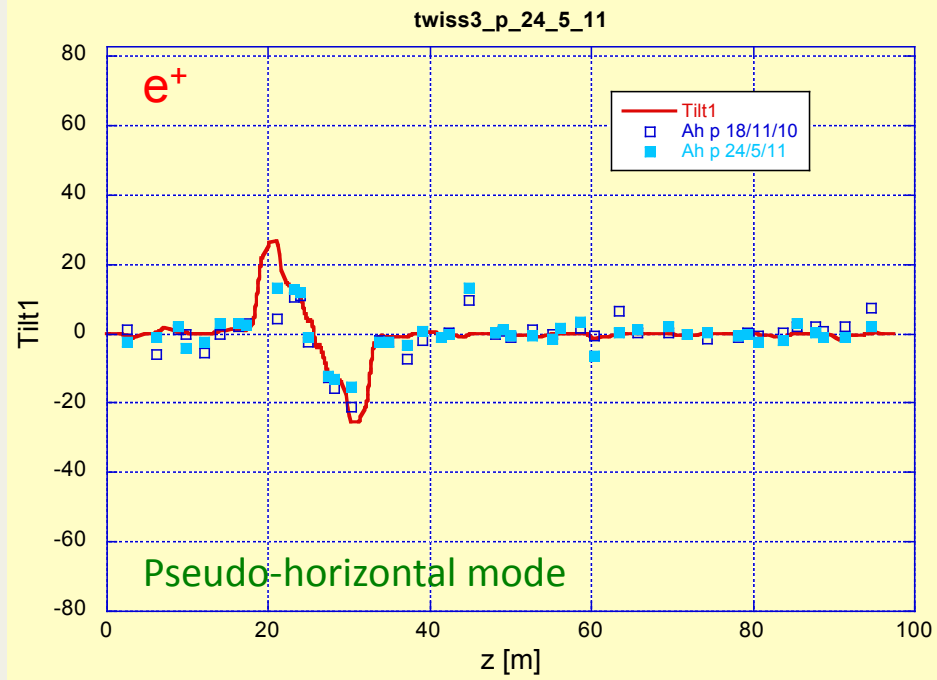

Vertical beam-beam *Luminosity scan*

$$\Sigma_y = \sqrt{\sigma_{yp}^2 + \sigma_{ye}^2}$$

$$\Sigma_y = \Sigma_y^{meas} * 0.88$$

May 2011

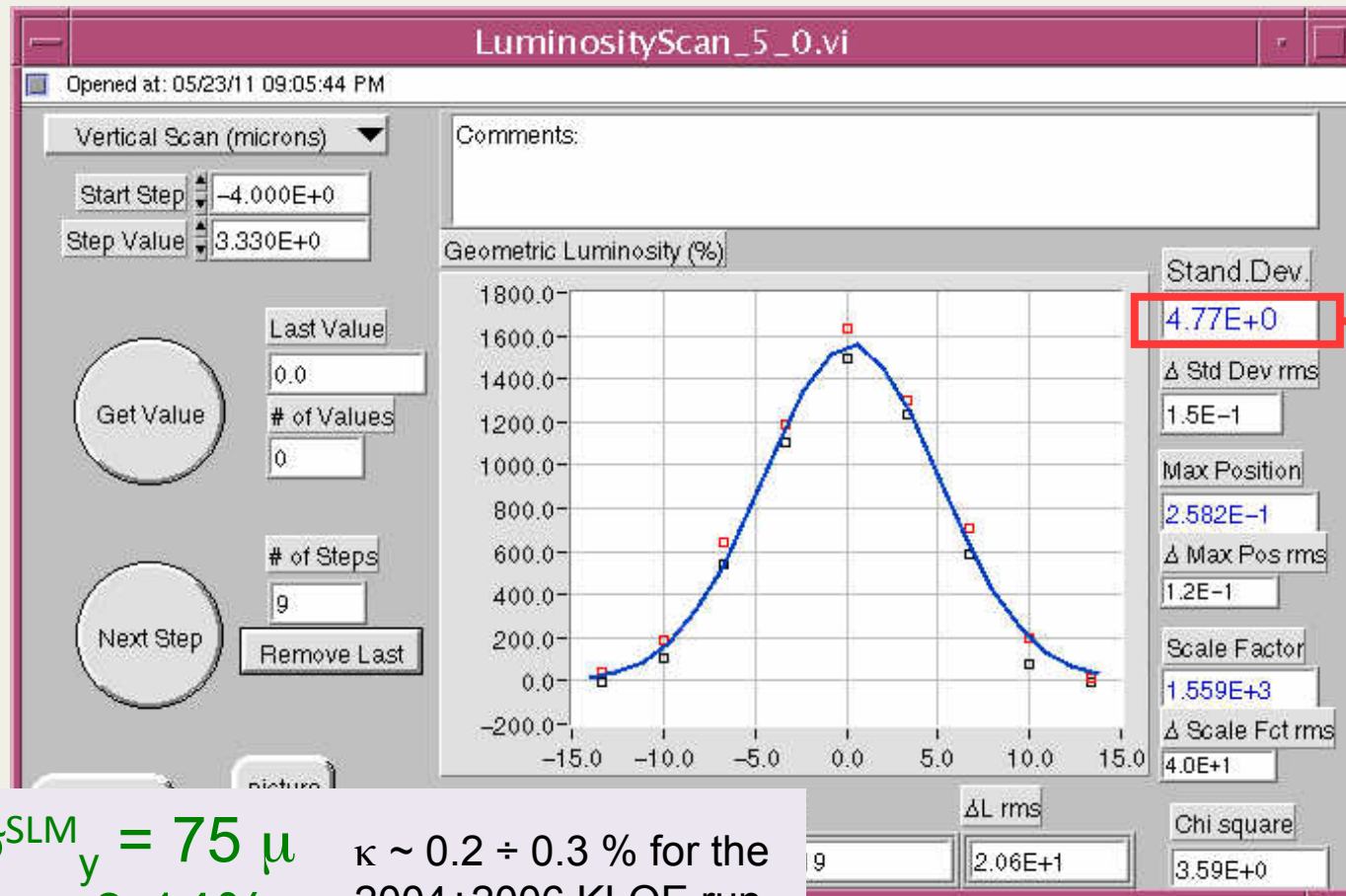

$\sigma_y \approx 3.0 \mu m$

$\sigma_y^{SLM} = 75 \mu$
 $\kappa \sim 0.14\%$

$\kappa \sim 0.2 \div 0.3 \%$ for the
 2004÷2006 KLOE run

Vertical beam-beam Luminosity scan (SIDDHARTA run)

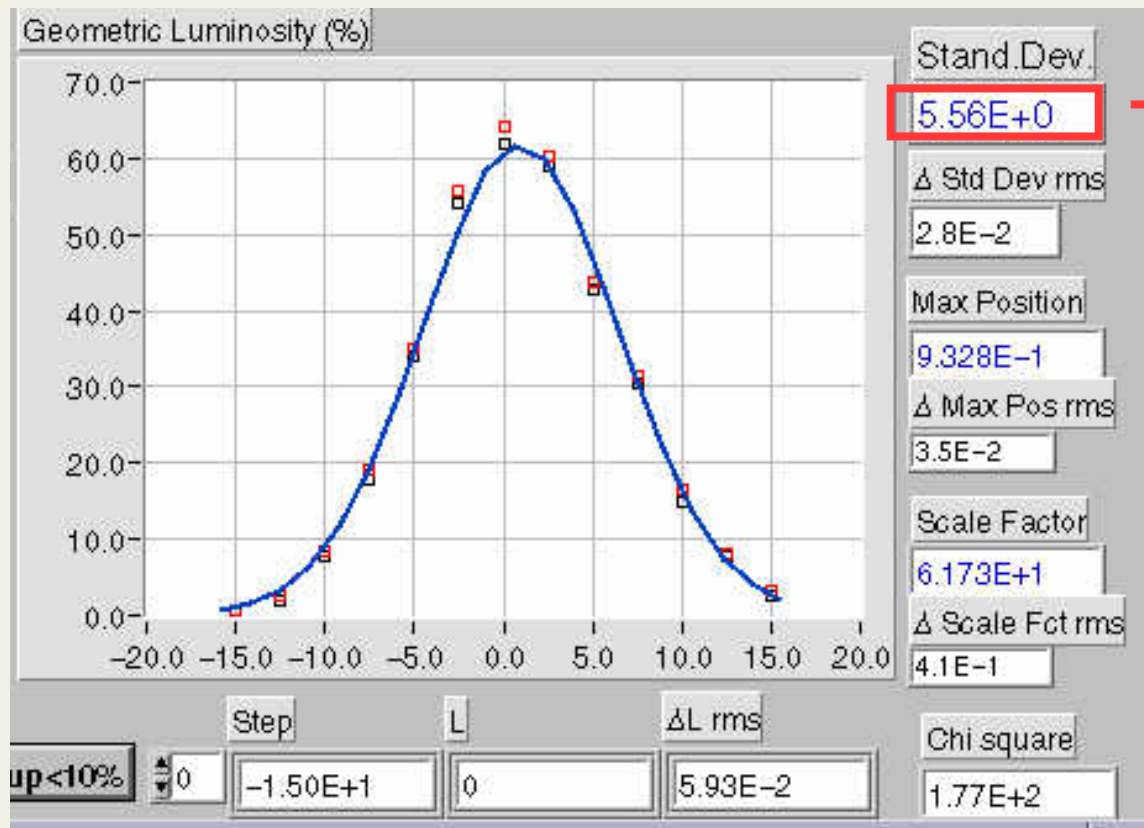

$$\sigma_y \approx 3.5 \mu\text{m}$$

Design value 3.1 μm

July 1st 2008
Presented PAC09

SIDDHARTA was a small detector without solenoidal field !!

Conclusions

The DAΦNE model has been essential in:

Setting up Collisions with:

Two low-beta

Low-beta in 1 IR and detuning the second one

FINUDA

DEAR

KLOE

SIDDHARTA

Crab-Waist collision scheme

KLOE-2

KLOE-2 with the solenoidal detector off

computing several optics configuration

Detuning alternatively one of the two IRs

Changing beam emittance

Tuning crossing angle and β in the IR

High momentum compaction

Negative momentum compaction

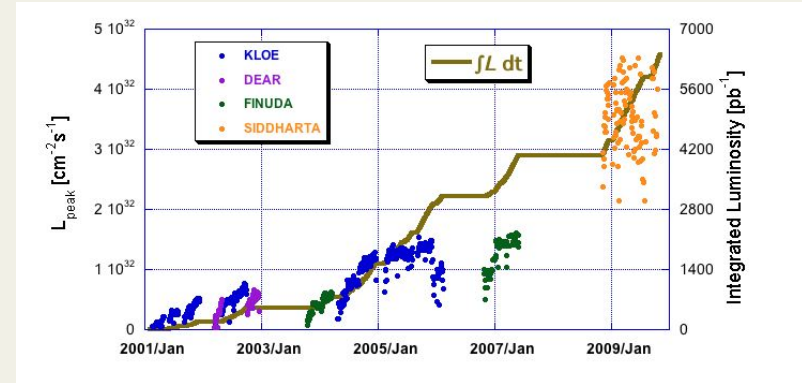

The model has been extensively used to investigate recognize and mitigate several limiting factors affecting the collider performances.

All those studies paved the way to the many progressive upgrades implemented on DAFNE during the past years

Acknowledgment

I like to thank: A. Stella, A. Drago, M. Preger, P. Raimondi, D. Alesini, M. Zobov