



# POLAR PROJECT STATUS

*U. Ammann<sup>2</sup>, T.J.-L. Courvoisier<sup>4</sup>, W. Hajdas<sup>1</sup>, D. Hass<sup>4</sup>, I. Herda<sup>1</sup>, M. Jaworski<sup>1</sup>,  
G. Lamanna<sup>5</sup>, C. Leluc<sup>3</sup>, R. Marcinkowski<sup>6</sup>, A. Mtchedlishvili<sup>1</sup>, M. Pohl<sup>3</sup>,  
N. Produit<sup>4</sup>, D. Rapin<sup>3</sup>, E. Suarez-Garcia<sup>1,3</sup>, Ch. Tao<sup>7</sup>, J.-P. Vialle<sup>5</sup>,  
R. Walter<sup>4</sup>, G. Wrochna<sup>6</sup>, B. Wu<sup>8</sup>, S. Xiang<sup>8</sup>, S.N. Zhang<sup>8</sup>*

<sup>1</sup>PSI Paul Scherrer Institut, Villigen, Switzerland

<sup>2</sup>PI Electronik, Daettwil, Switzerland

<sup>3</sup>DPNC, Universite de Geneve, Switzerland

<sup>4</sup>ISDC, Universite de Geneve, Switzerland

<sup>5</sup>LAPP/IN2P3/CNRS, Annecy, France

<sup>6</sup>IPJ, Warsaw, Poland

<sup>7</sup>CPPM, Universite de la Mediterranee, France

<sup>8</sup>IHEP and China Academy of Science, Beijing, China





# Outline

- Laboratory Results
- Demonstration Model Development
- Monte Carlo Simulations
- Launch Opportunities



# POLAR Reminder

- Novel Gamma Ray Burst Polarimeter
- Principle: Compton scattering
- Construction: uniform array of 40x40 low Z, fast scintillators
- Signal conversion: new multi-anode photomultipliers
- 3 x large:
  - area  $\sim 600 \text{ cm}^2$
  - field of view  $\sim 1/3$  of the sky
  - modulation factor  $\mu_{100} \sim 35\%$

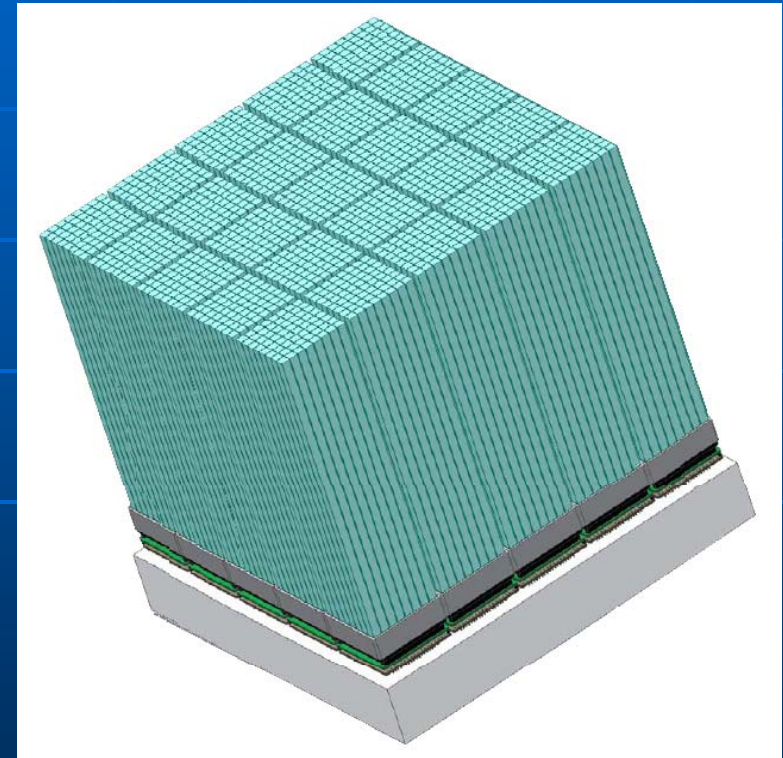



# Engineering Model with SNF

- Proposal accepted by SNF - 804 kCHF, Kick-off meeting April 2007
- Foundation Schmidheiny – 50 kCHF for PMs
- Engineering/Qualification Model in 3 years until May 2010
- Aimed for launch opportunity around 2012

Berne, le 15 mars 2007

**Décision**

**200021-116081 / 1**

Monsieur,

Nous avons le plaisir de vous informer que le Conseil de la recherche a décidé de vous allouer un subside de recherche de CHF 804'570.00 pour le projet "POLAR - Wide Field Polarimeter for Hard X-Rays from Gamma-Ray Bursts".



# Plastic Scintillator BC400

- Roughness:
  - Glass side highly, saw cut side fairly well polished
  - Height distribution STD  $\approx 50 \text{ \AA}$  (glass) and  $150 \text{ \AA}$  (saw cut)
- Light Collection:
  - Best results with 3M wrapping foil
- Linearity:
  - Amplitude shift for Teflon, Al and 3M foil wrapping  
 $\Delta P/P = 10\text{-}15\%$

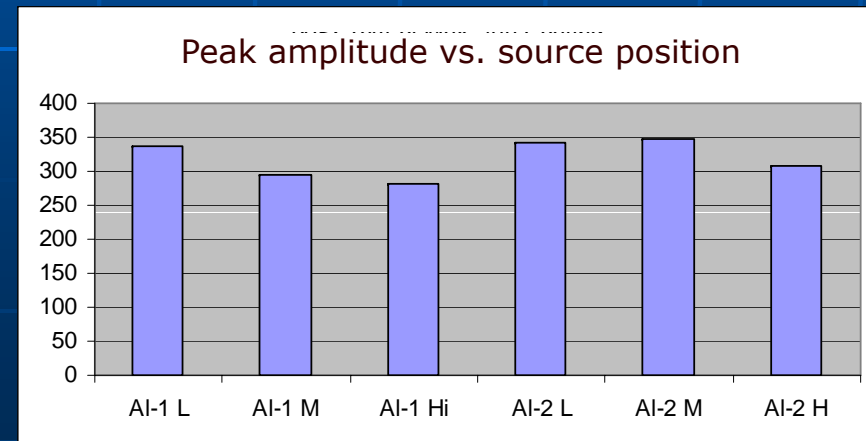
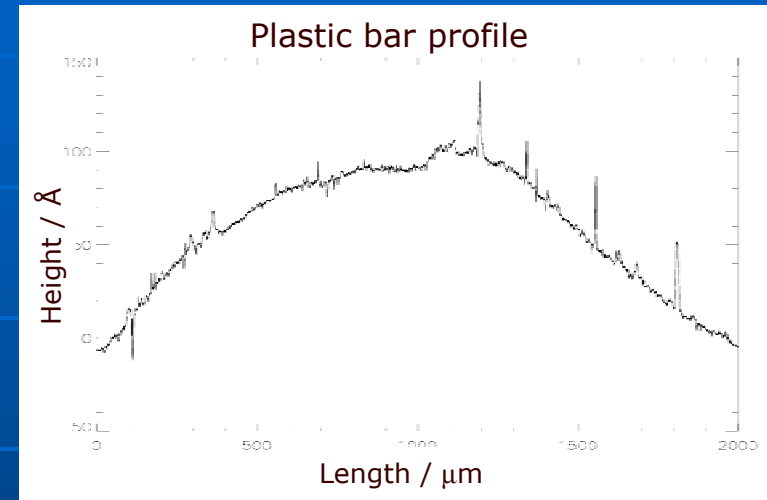



# HAMAMATSU MAMPT H8500

- Threshold studies:
  - Threshold of 5 keV possible
  - Pulse height variations between anodes by a factor of 2
- Vibration studies:
  - Shaker at Bern University
  - Levels for China Space Lab
  - No performance worsening

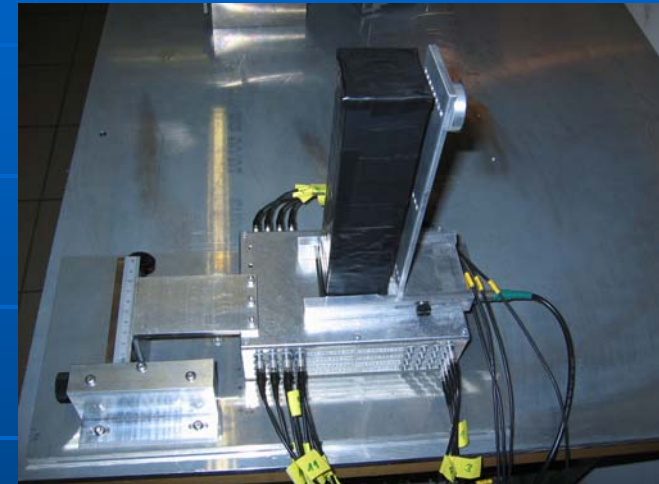





# Demonstration Model

- POLAR concept with DM for 2x64 channels
- Testing functionality and major characteristics
- Study modularity and data flow from two PMs
- Development with industry (PI Elektronik, Daettwil)

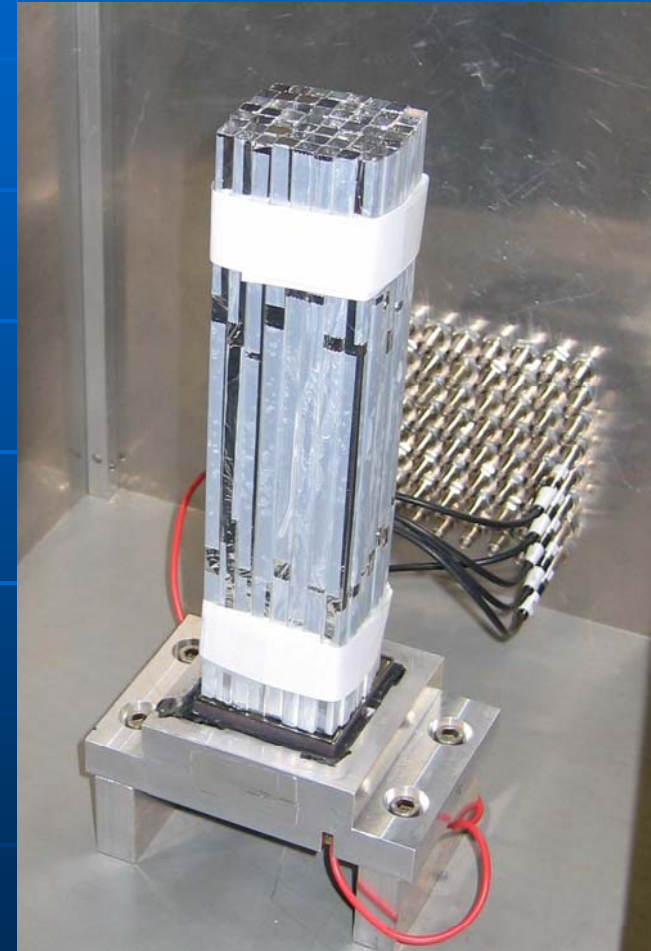



# DM Scheme

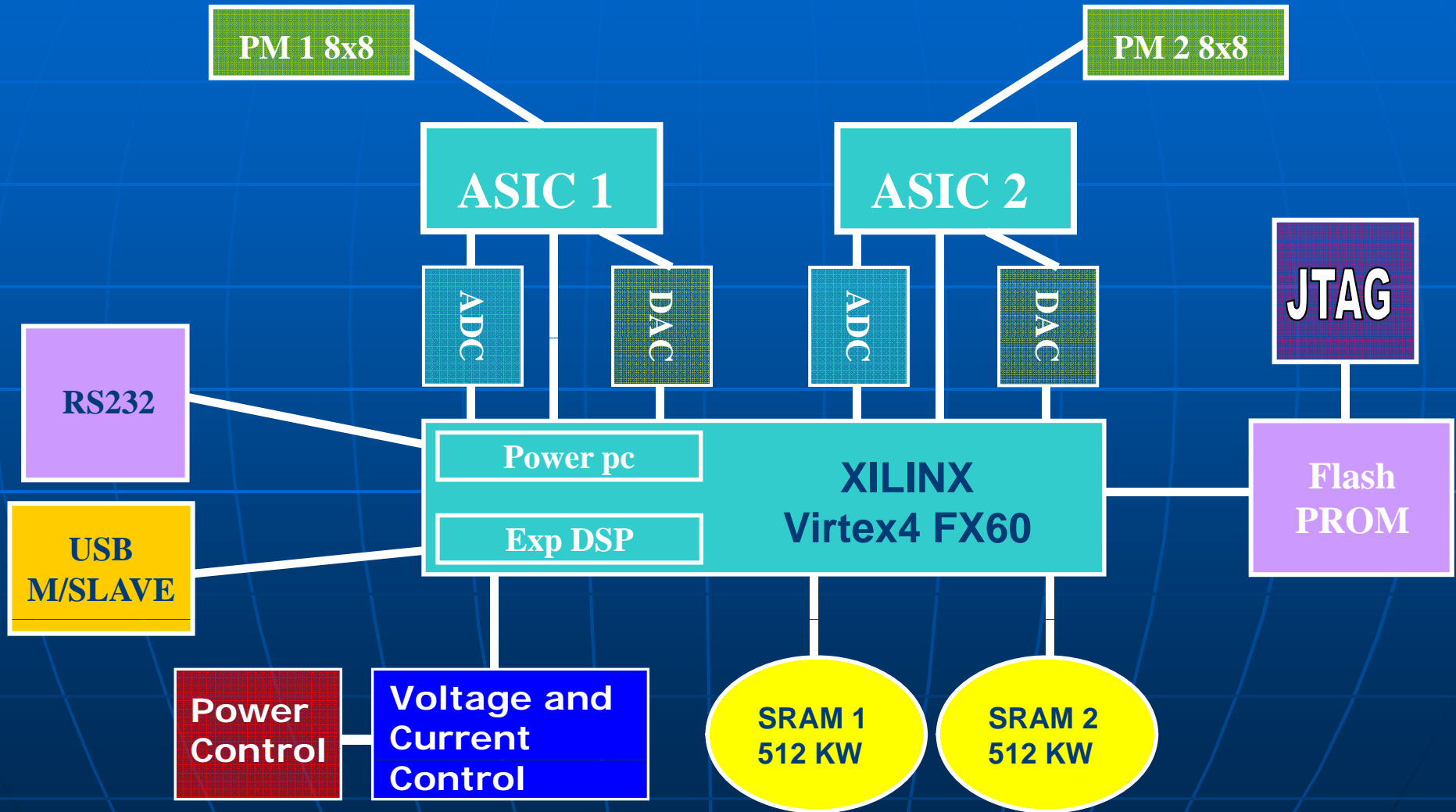





# DM Assembled Board

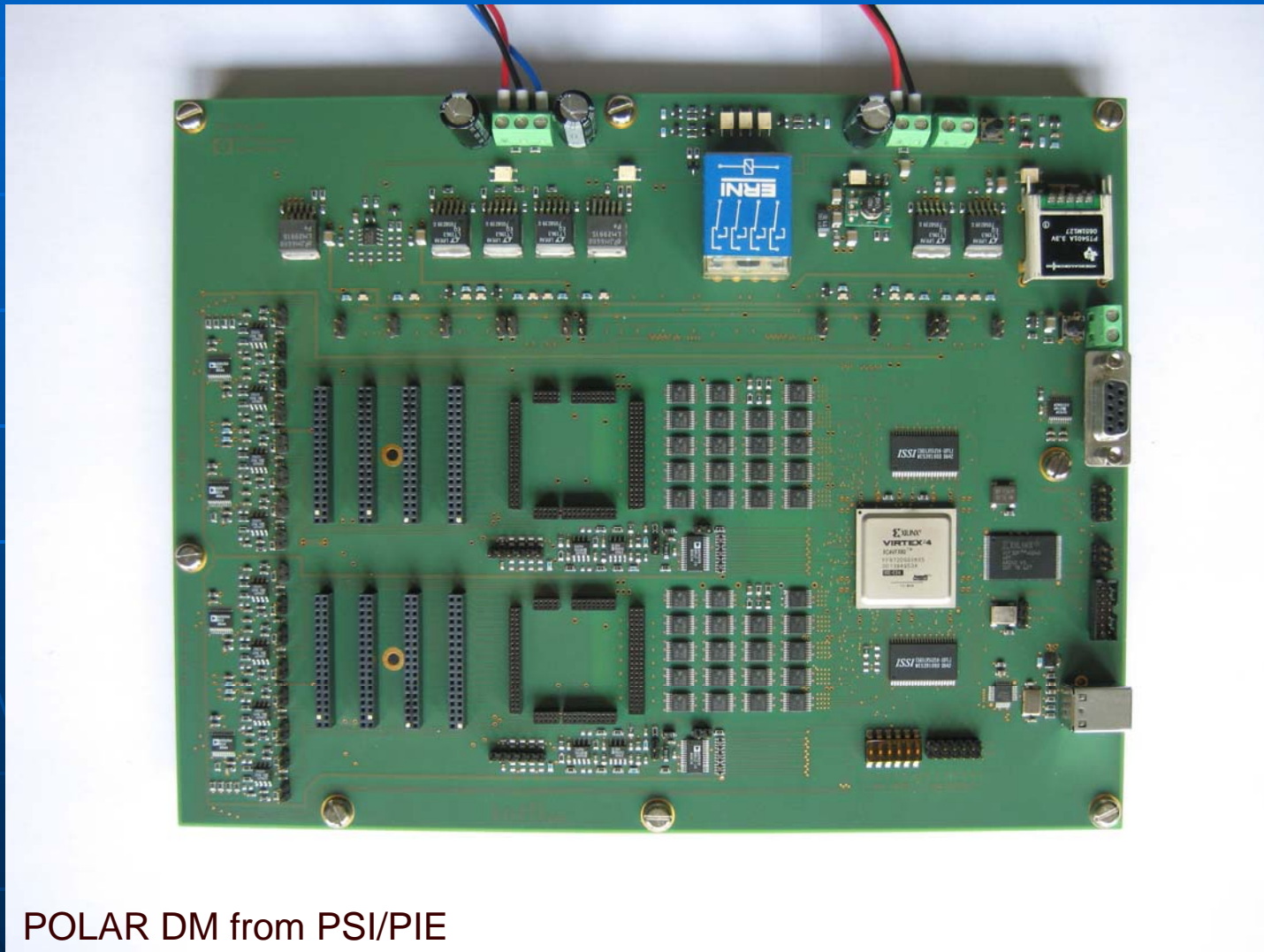

POLAR DM from PSI/PIE

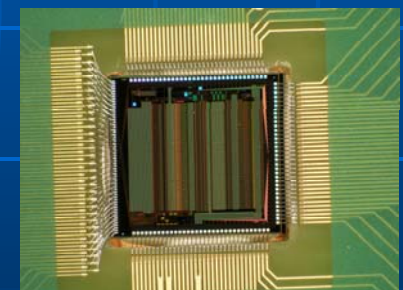
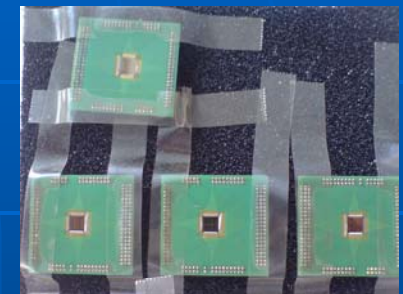

VA64MAPMT ASIC  
from IDEAS with  
PSI/HighTech PCB



# Monte Carlo Simulations

- Model in GEANT4:
  - Size 240x240x200 mm<sup>3</sup>
  - Single plastics 6x6x200mm<sup>3</sup>
  - User defined:
    - Shielding and wrapping
    - Photon spectrum, direction and polarization
  
- Modulation Factor results:
  - Example for 150 keV:
    - $\mu_{100} = 35 \pm 1 \%$
  - Analysis with ROOT

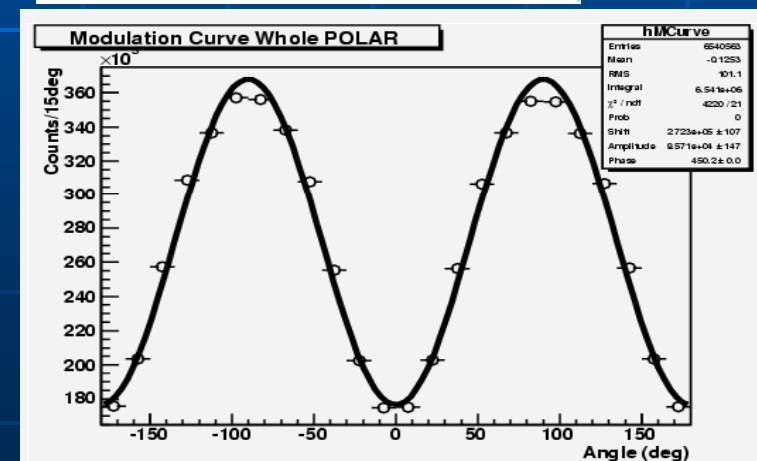
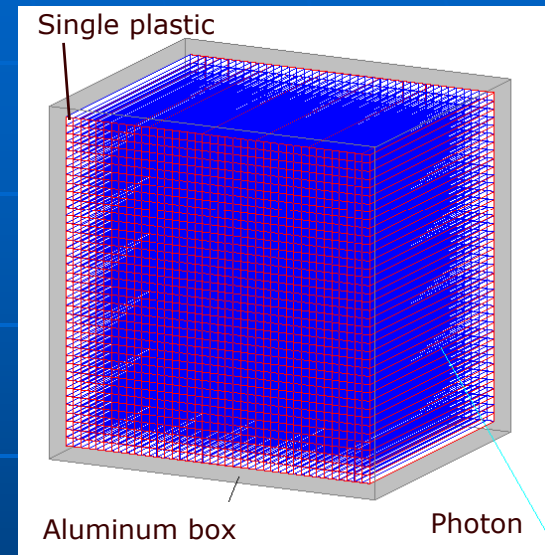



# MC Light Collection

- Scintillation and Optical Photons packets in G4:
  - Photon yield, attenuation length, refraction and roughness
  - Reflective index of wrapping
  - PM Glass thickness and surface parameters & optical grease
- Results:
  - 45% optical photons detected
  - Difference for top-bottom photon collection by 10-20 %
  - Polishing of the scintillator surface crucial
  - 3M foil with reflective index > 0.99 best

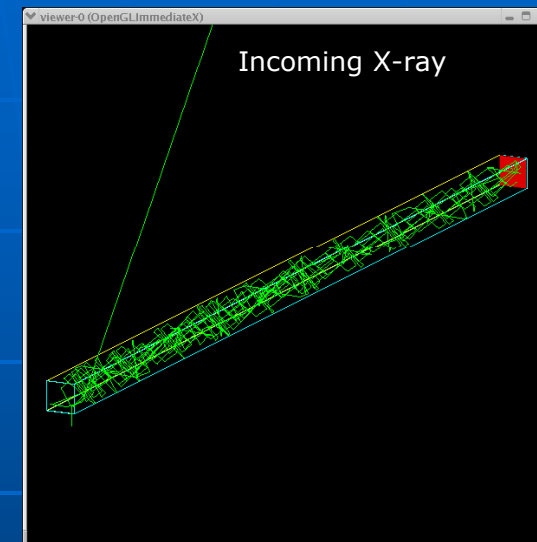

Tracks of optical photons in plastic bar

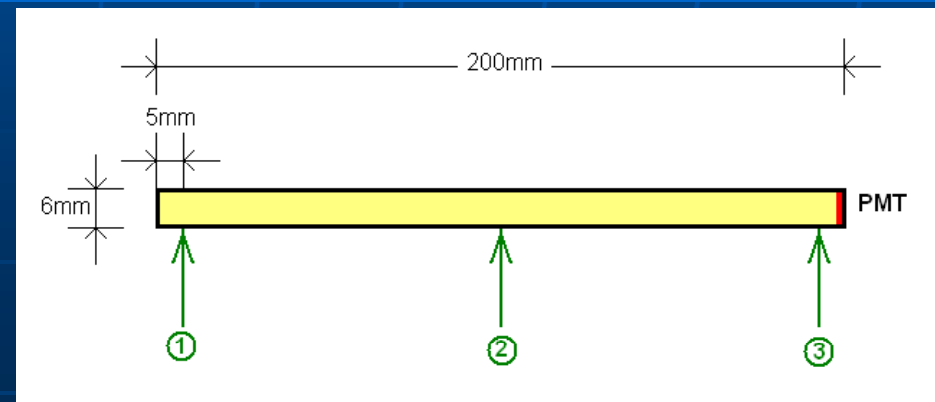

Simulation setup with  $\gamma$ -ray injection points



# MC Orbital Studies

- Particle environments from NASA AP8/AE8 models and Cosmic Rays
- Suitable orbit is LEO (ISS), except of SAA
- GEO has too high background from electrons
- Cosmic Rays rate low  $\sim 1000 \text{ s}^{-1}$ , further discrimination possible
- Using CR for calibration under studies (board design, PIF facility verification)

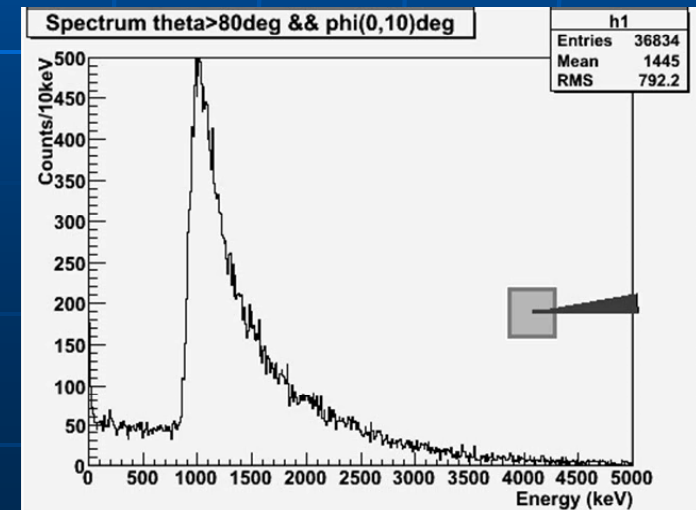
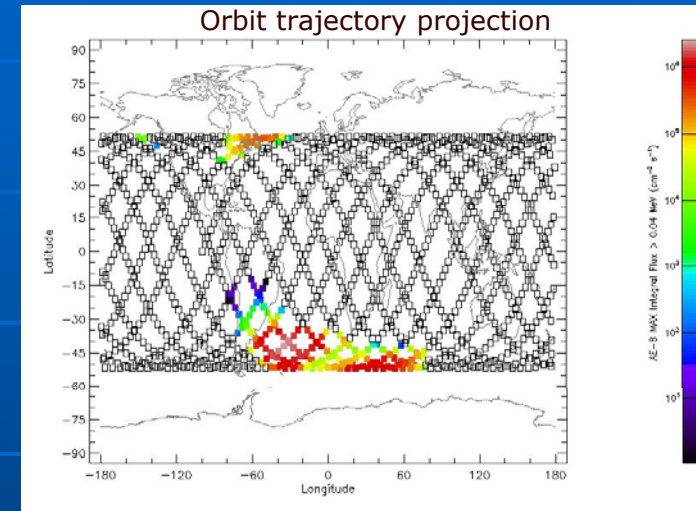



# Polar vs BATSE GRB Catalog

- Realistic distribution of Minimum Detectable Polarizations in 1 year
- Using GRBs parameters provided by BATSE CGRO
- Bursts frequency: 210 bursts/year
- Strong GRBs seen in POLAR FOV:
  - $F_{\text{tot}} > 10^{-5}$  /erg/cm<sup>2</sup>
  - $\sim 12$  GRB /year
  - MDP  $\sim 10\%$  ( $3\sigma$ )
- Mission objectives fulfilled in 2-3 years

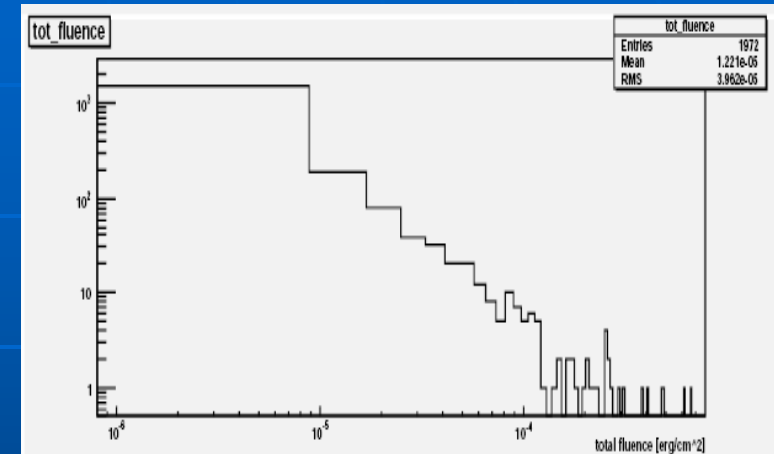

BATSE GRB total fluence distribution 1991-2000

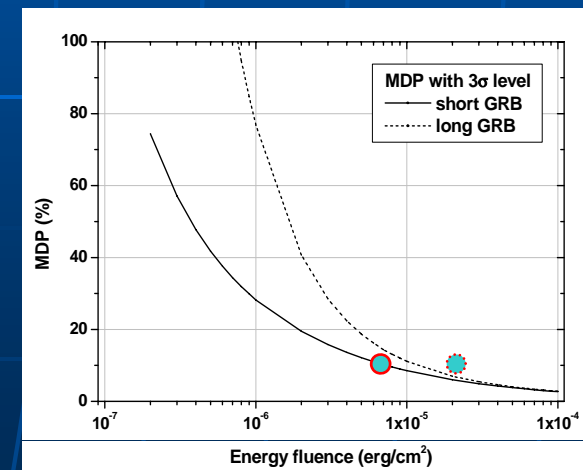

POLAR MDP sensitivity curve with 2 BATSE GRBs:  
5563 – short and 6763 - long





# Flight Possibilities

- Proposal for Flight Model with SSO PRODEX program
- Chinese Space Lab, ~2012
  - Collaboration with Institute for High Energy Physics and China Academy of Science established
- International Space Station
  - Topic group will be created at ESA for POLAR on Columbus
  - Call for proposals in 2008

Chinese Space Lab



International Space Station



Columbus Module





# Road Map for China's Space Astronomy and Solar Physics

From presentation of S.N. Zhang during IHEP-Beijing meeting on 18<sup>th</sup> Sep 2007

A journey to the Sun and black holes

Astrophys Res.: data analysis, theory & computation based on space astronomy data

Capacity building and enabling technology: platform, detector, electronics, telescope

Education and public outreach: future space scientist, public understanding of science

The Sun as the closest laboratory of astronomy & astrophysics

Micro-satellite on explosive high energy solar activities

Midrange-satellite on solar magnetic element

Advanced solar Astronomy observatory

Generation and reconnection of magnetic field, shock, particle acceleration  
Jet, stellar evolution, compact object, galaxy formation, cosmic structure...

Black holes as probes of stellar and cosmic evolutions

Spacelab or small-satellite on explosive high energy phenomena

SVOM, POLAR

Midrange-satellite as finder of Hidden supermassive black holes

HXMT, Simbol-X

Large-satellite as observatory on black hole environments

XEUS?  
GRI??  
XTP??

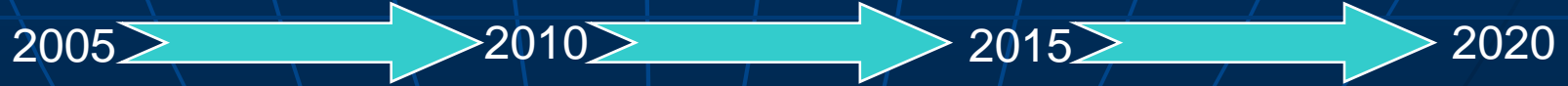



# Summary

- Manufacturing of POLAR EM secured by SNF (3 years)
- Team with 3 Swiss institutes created
- International collaboration established
- First set of feasibility studies successfully finished
- Comprehensive Monte Carlo model developed
- Demonstration Model (2x64) under first tests (PSI, PIE)
- FM financing and flight opportunities defined



# Thank You !

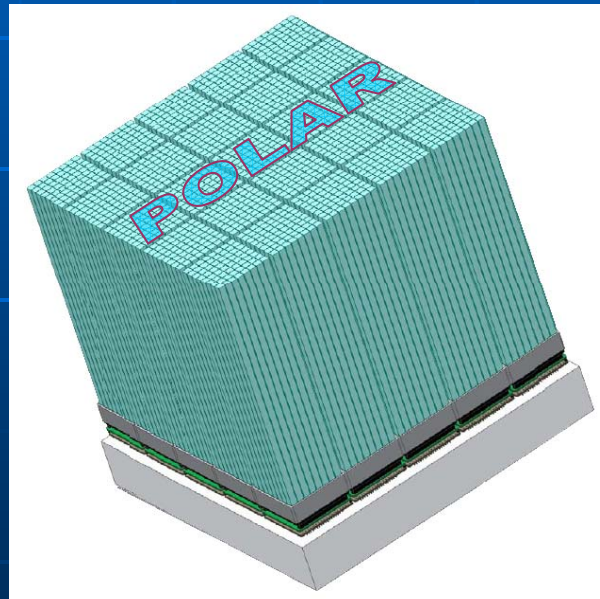



# POLAR Goals and Firsts

- Polarization in  $\gamma$ -rays neglected to date !
- First systematic and accurate determination of polarization
- Providing final observable to find true nature of GRBs – biggest explosions in the universe
- Probing magnetic field strength and topology during birth of Black Holes
- Testing Quantum Gravity theories with experiment
- Verifying of the Lorentz invariance
- Looking into Universe Dark Ages