



## PPAC monitoring at EAR2

**L. Tassan-Got, L. Audouin, C. Le Naour,  
C.O. Bacri CACAO, NEEDS**  
*IPN Orsay-France*

**I. Duran , E. Leal**  
*Santiago de Compostela - Spain*

**n\_TOF collaboration**  
*CERN - Switzerland*

### Topics and tasks

- Construct a new vessel with 2 or 3 PPACs and 1 or 2 targets (USC)
- New dedicated gas regulation (USC)
- Change the front end electronics to stand the high counting rate (IPNO)
- Make 2 or 3 PPAC dedicated to the monitoring (IPNO)

### DAQ requirements

- Beam characterization mode : 10 or 15 FADC channels
- Monitoring mode: 2 or 3 FADC channels

## Instantaneous counting rate

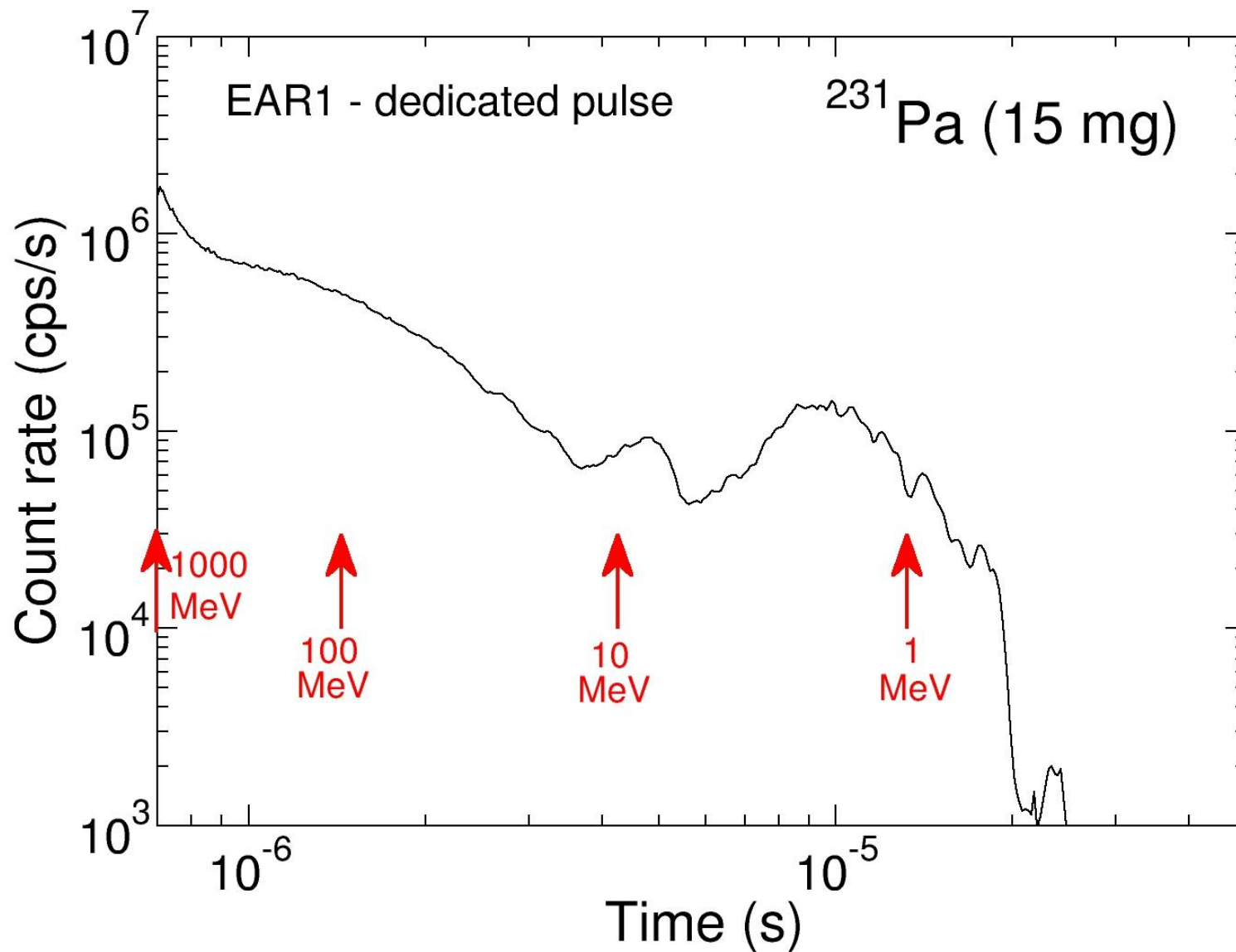

# Pile up of localisation signals

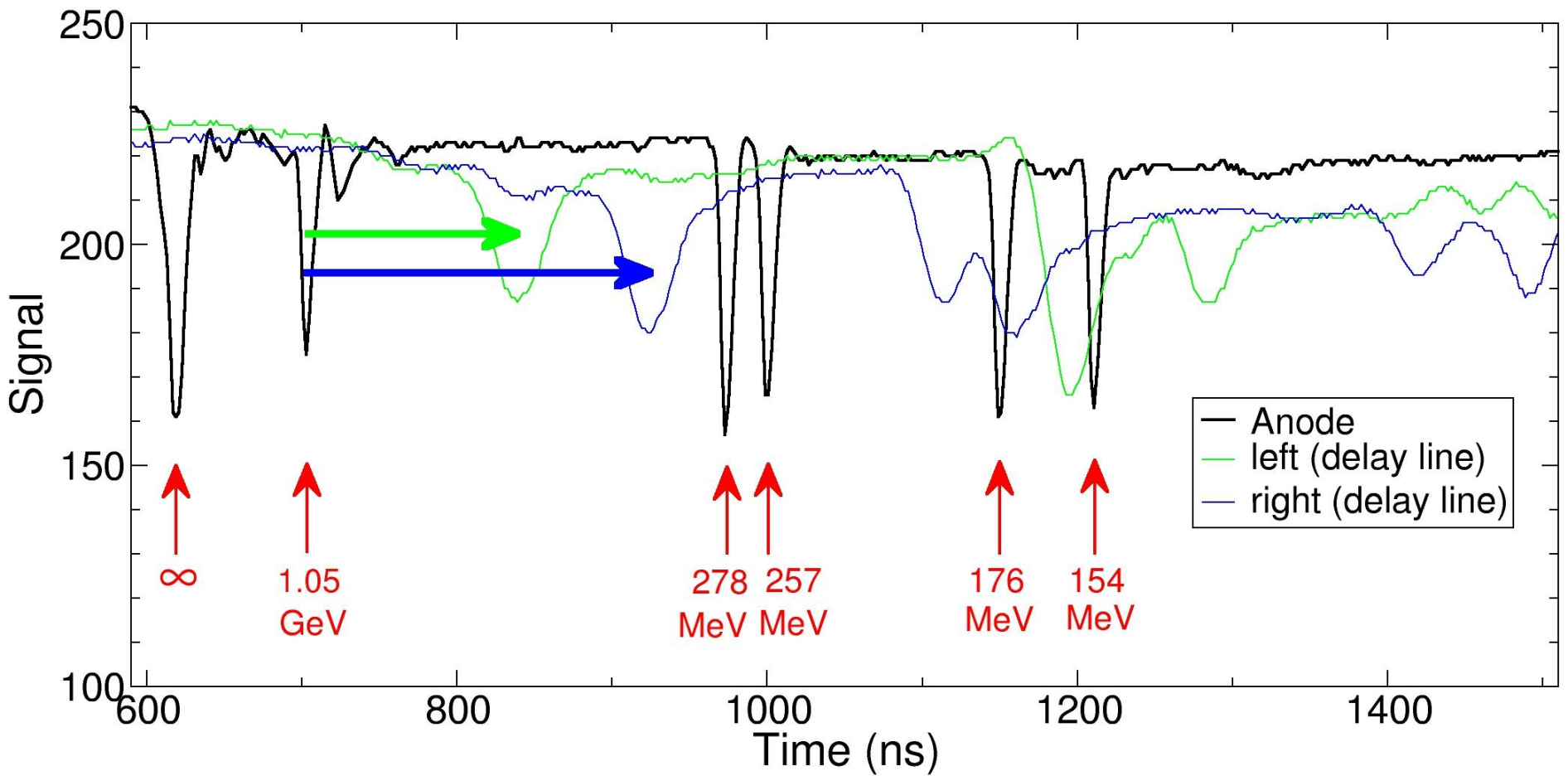

## EAR2 modification of electronics

- Change the 20 delay lines : 320 ns  80 ns
- Change the charge sensitive preamps to fast current preamps
- FADC at 1 GS/s desired
  
- For fission: beam spot of 3cm in diameter is enough

# Conceptual drawing

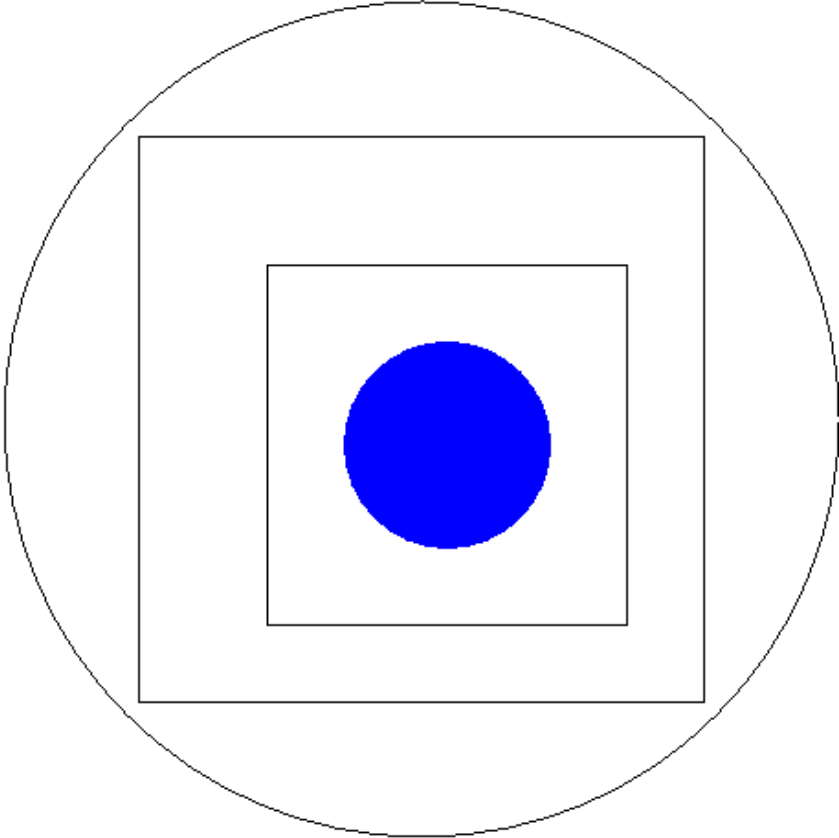
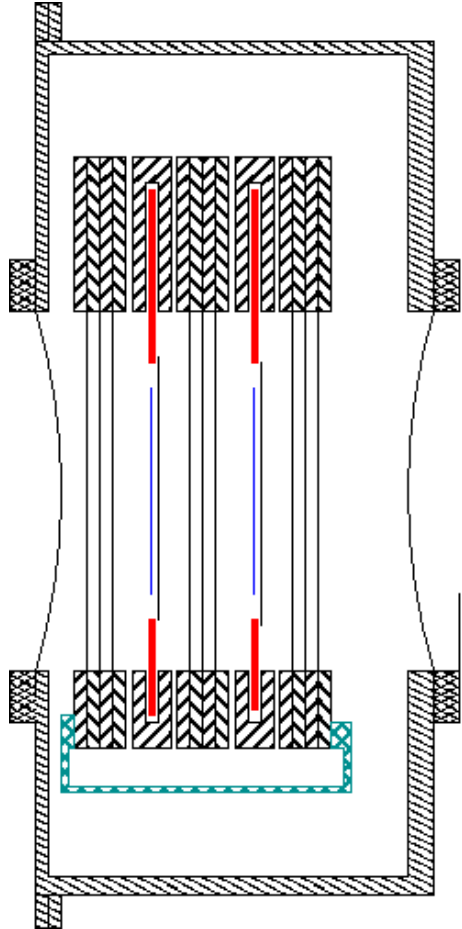

# Preliminary design (USC+Vigo)

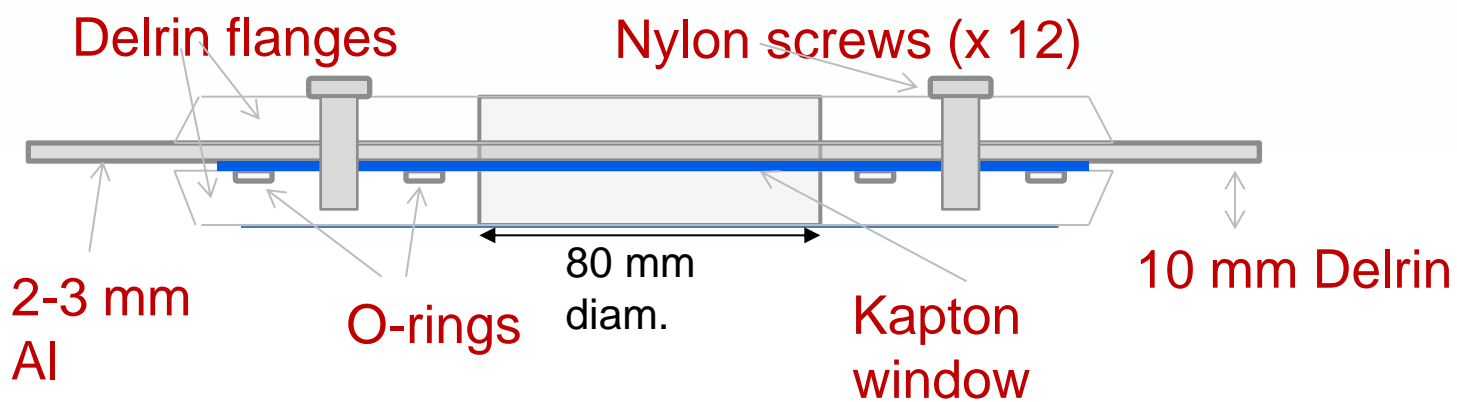
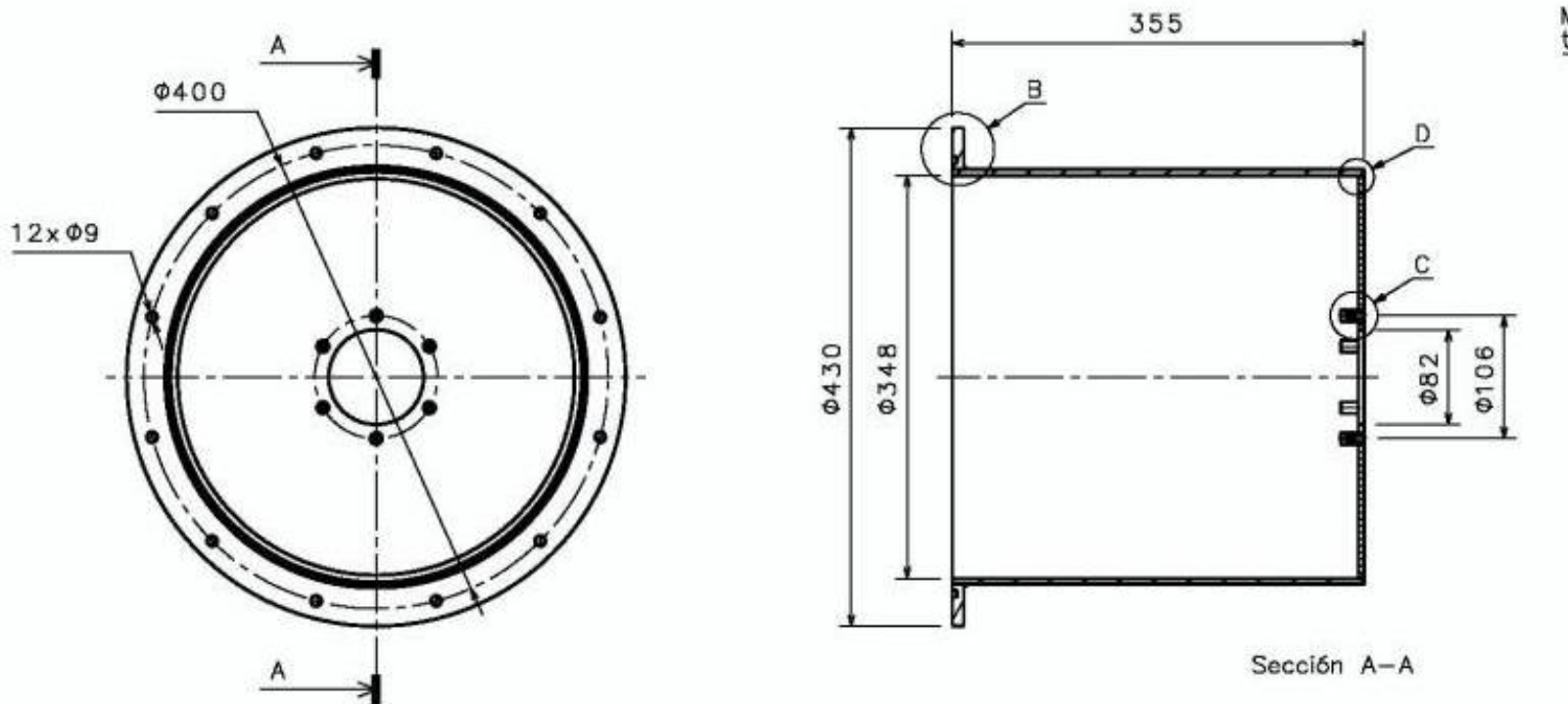

# Preliminary design (USC+Vigo)

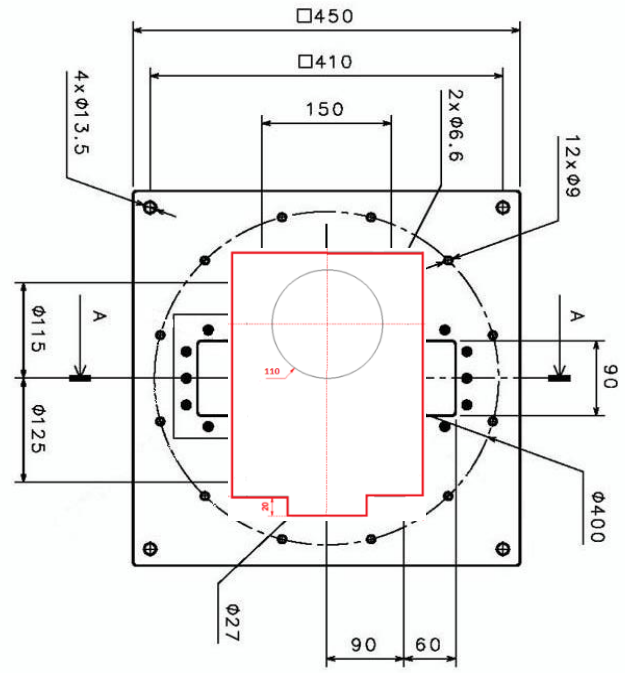
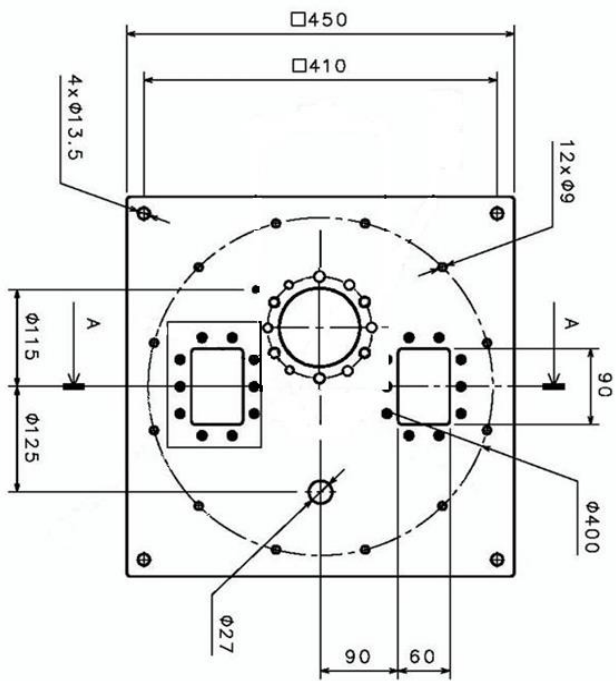

Sección A-A

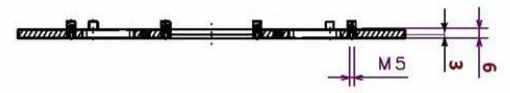



### Present status

- Front end electronics funded by Needs, will start in January
- PPACs not financed, but for commissioning we have 2 spare PPACs
- $^{235}\text{U}$  targets have to be done, but we have 2 in spare for the commissioning
- Gas regulation hopefully financed by USC. Will come late but for commissioning we can use the IPNO one.
- Vessel hopefully financed by Vigo, absolutely needed for the commissioning, only first draft at the moment and a lot of design has still to be done. For the commissioning the IPNO chamber could be used, but cumbersome.