

**BANK\_33\_34\_35\_36**

SHEET=22

**IO\_CONNECTORS**

SHEET=66

**PGP**

SHEET=2

**ZONE3\_CONNECTORS**

SHEET=13

**FRONT\_PNL\_CNTRL**

SHEET=SHEET

**EV**

SHEET=3

**ZONE3\_GPIO**

SHEET=13

**BANK\_32**

SHEET=13

**PCIE**

SHEET=4

**PWR\_REG**

SHEET=8

FPGA\_POR — FPGA\_POR

**FPGA\_PWR**

SHEET=6

**FPGA\_CONFIG**

SHEET=7

FPGA\_POR — FPGA\_POR

**FPGA\_UNUSED**

SHEET=5

AD7P  
AD7M  
AD15P  
AD15M

AD7P  
AD7M  
AD15P  
AD15M

AD7P  
AD7M  
AD15P  
AD15M

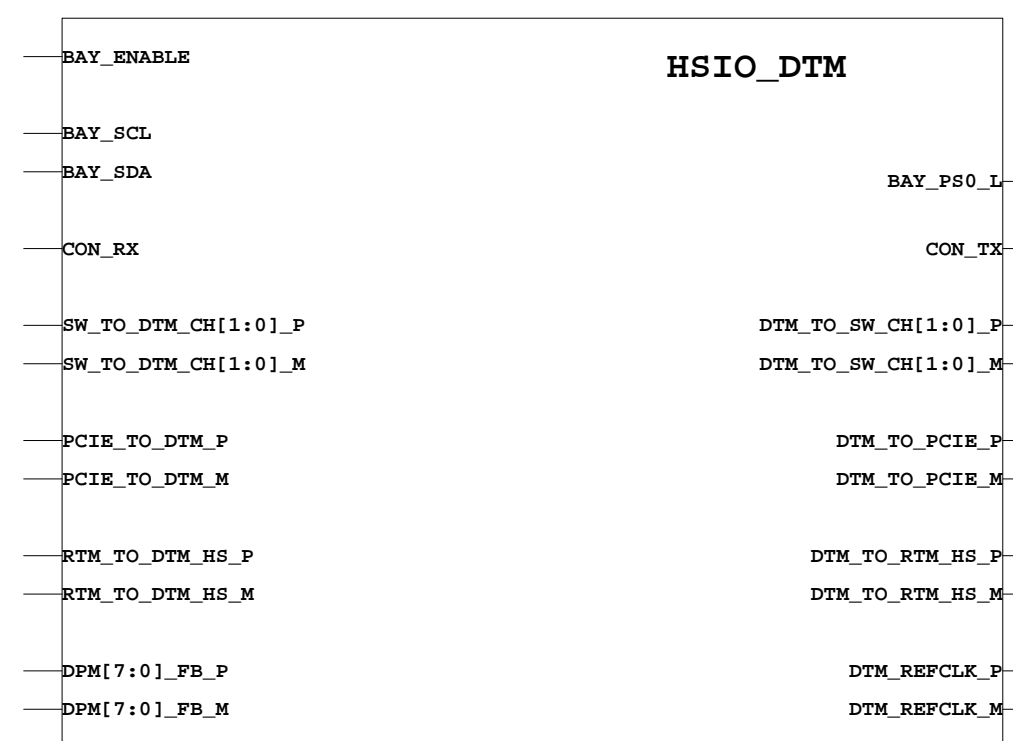

SLAC NATIONAL ACCELERATOR LABORATORY U.S. DEPARTMENT OF ENERGY <small>STANFORD UNIVERSITY STANFORD, CALIFORNIA</small>		
<small>PROPRIETARY DATA OF STANFORD UNIVERSITY AND/OR U.S. DEPARTMENT OF ENERGY. RECIPIENT SHALL NOT PUBLISH THE INFORMATION WITHIN UNLESS GRANTED SPECIFIC PERMISSION OF STANFORD UNIVERSITY.</small>		
ENR	DATE	APPROVALS
Larry Ruckman	2013	
DFR		
CHK		

SHEET 1 OF 8
<b>PGP CARD Generation 3</b> <b>TOP LEVEL BLOCK</b>
<b>LOCATED AT SHEET TOP</b>
SD-260-101-03-C00

31/01/2014:13:46

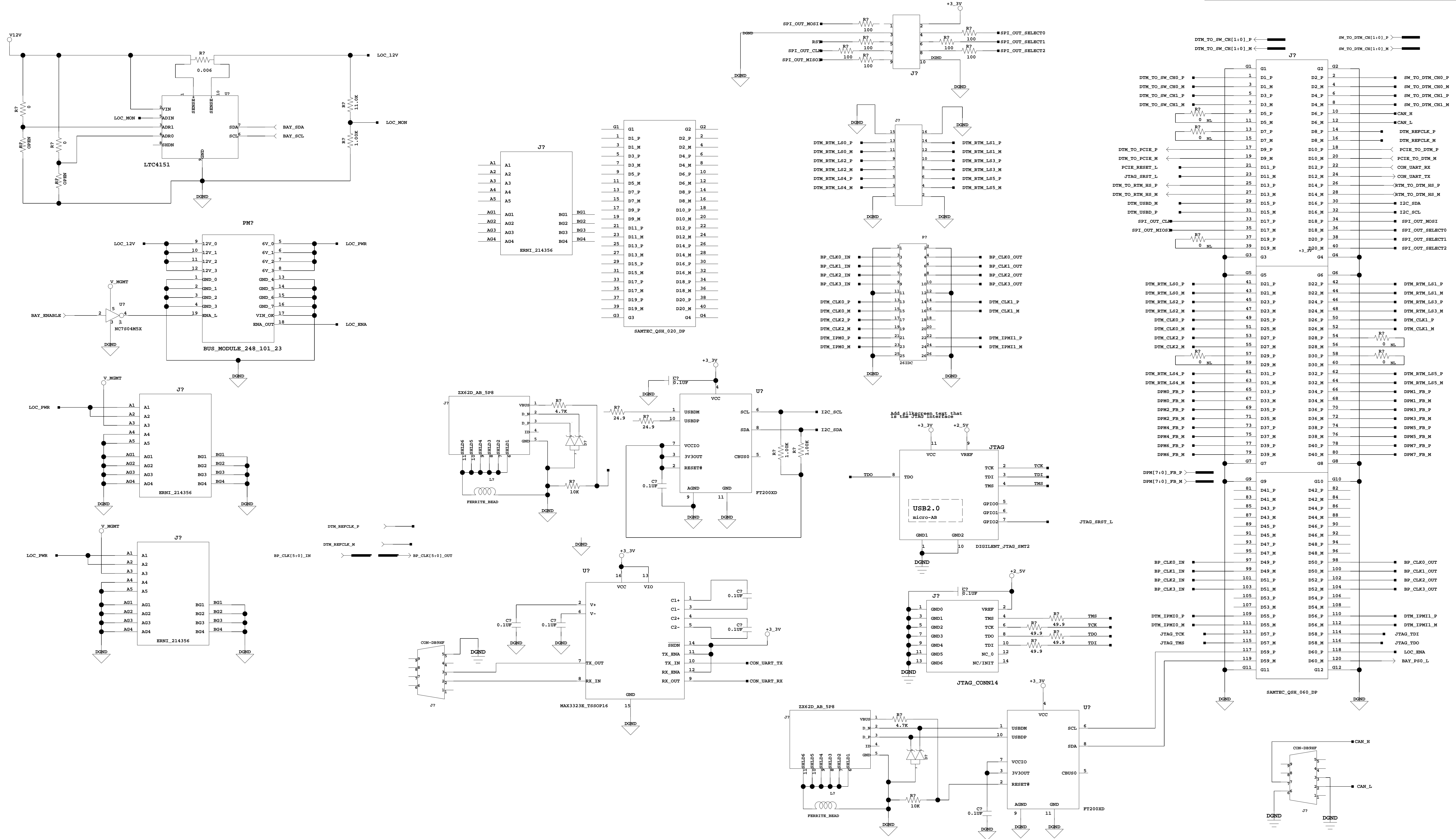

[Empty box for signature or date]







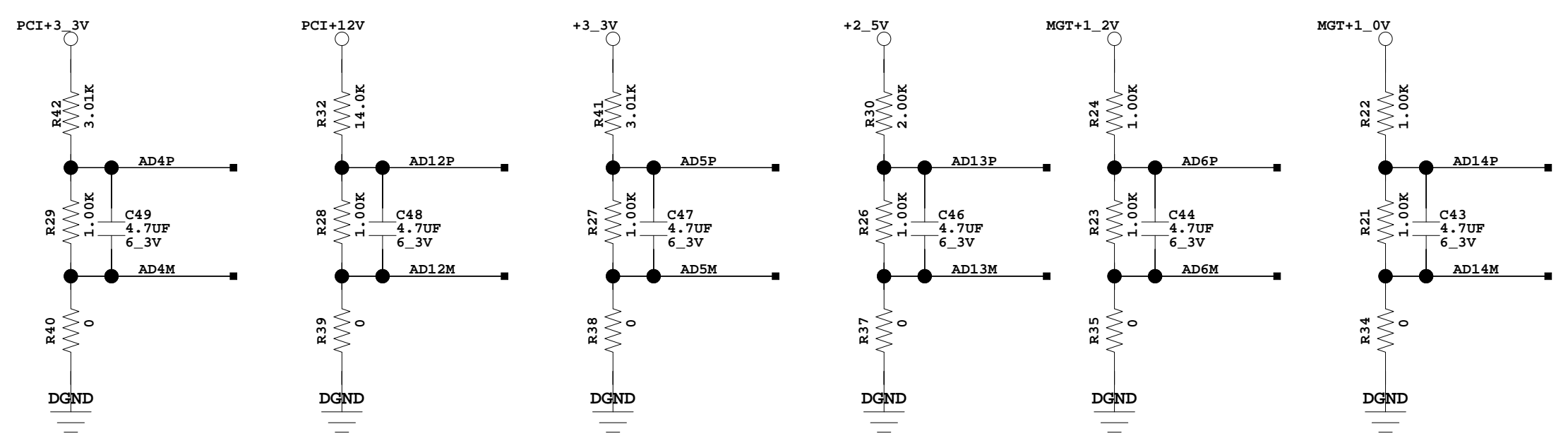
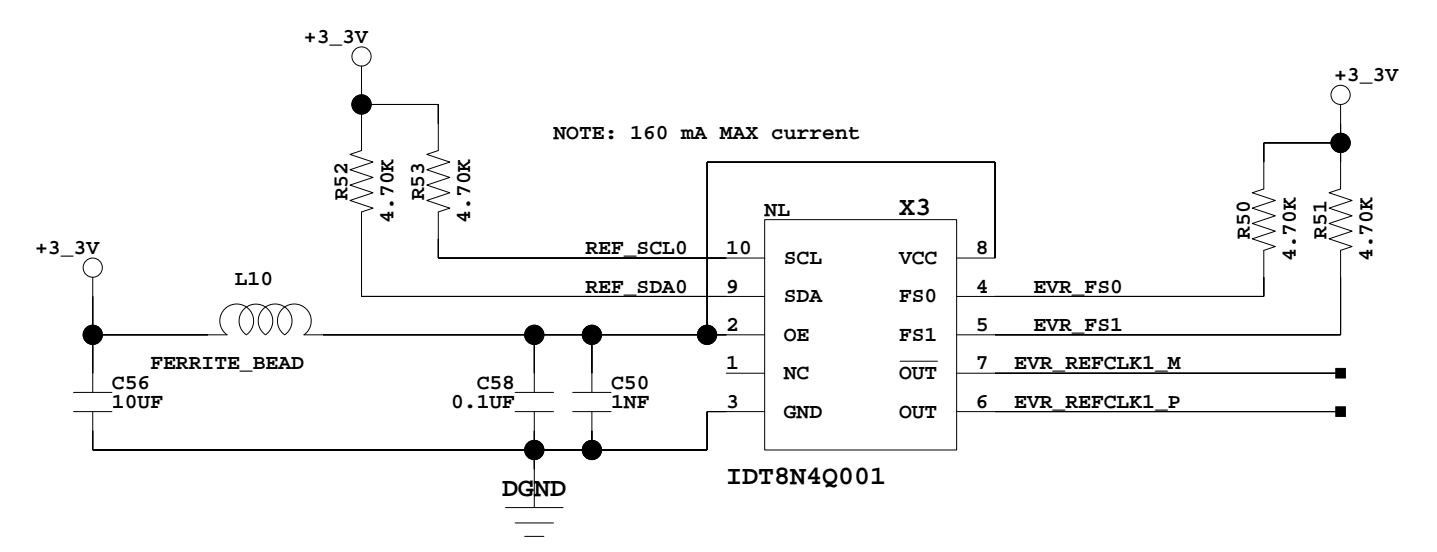
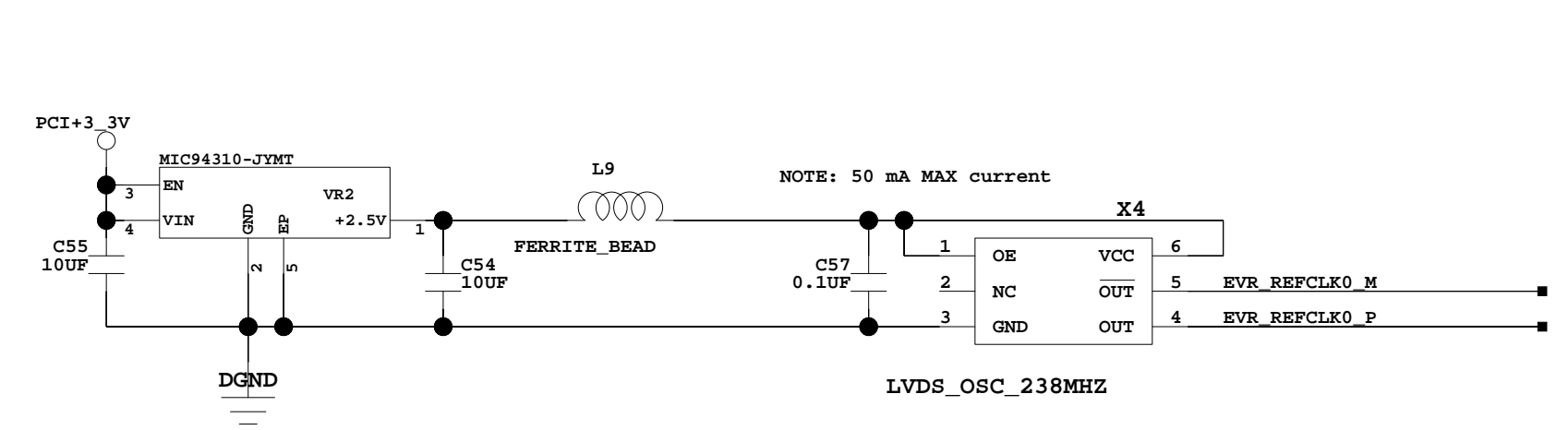
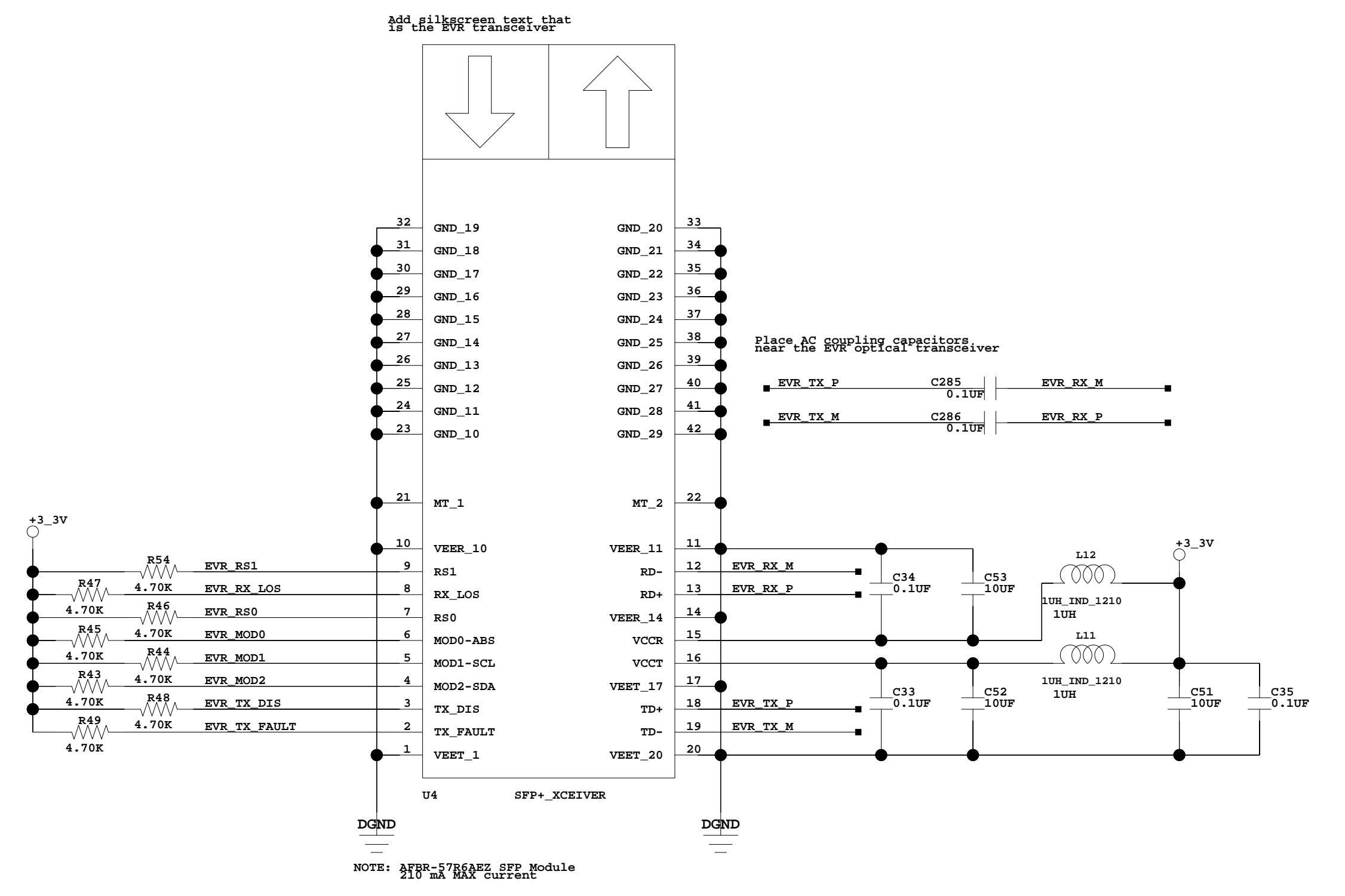
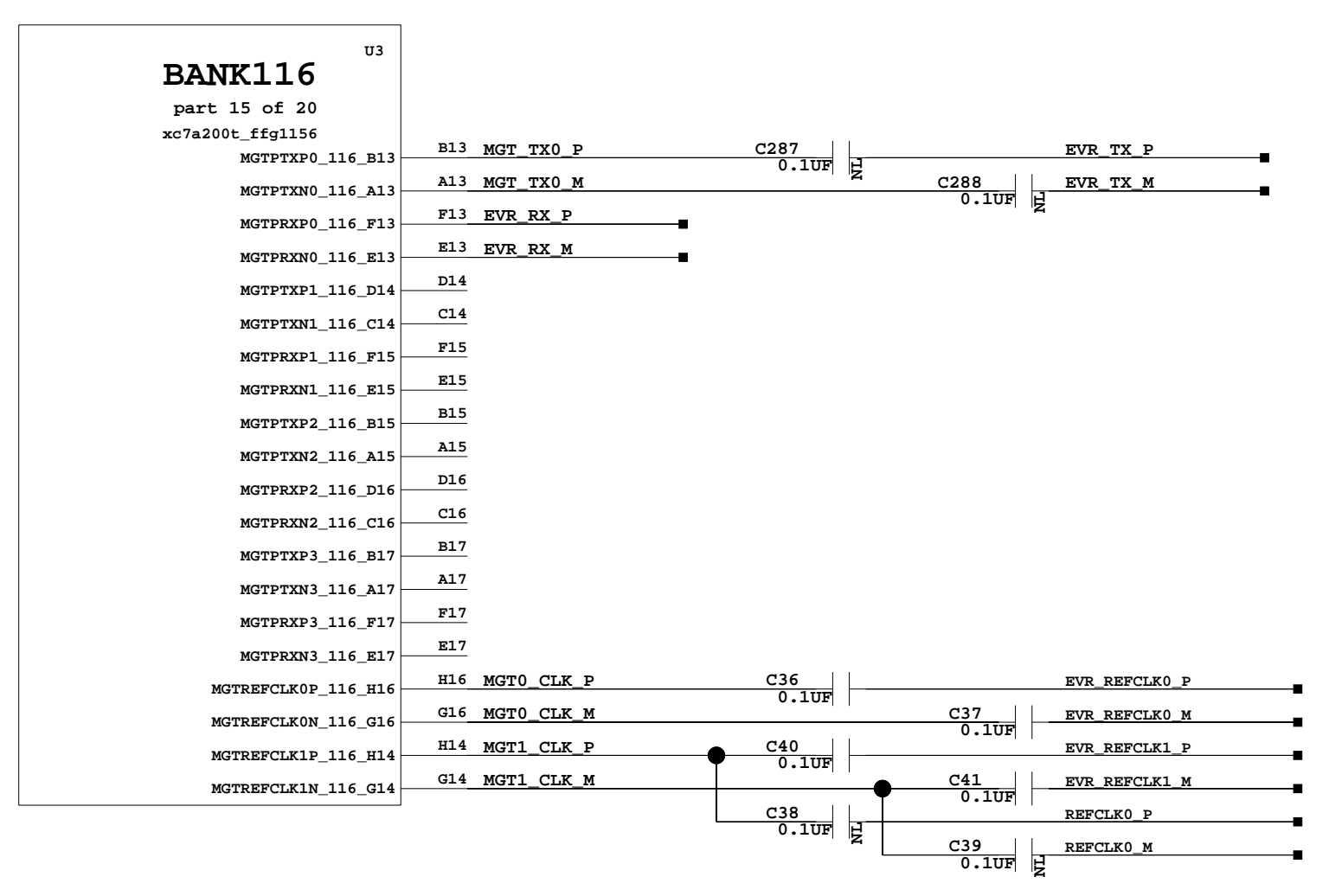
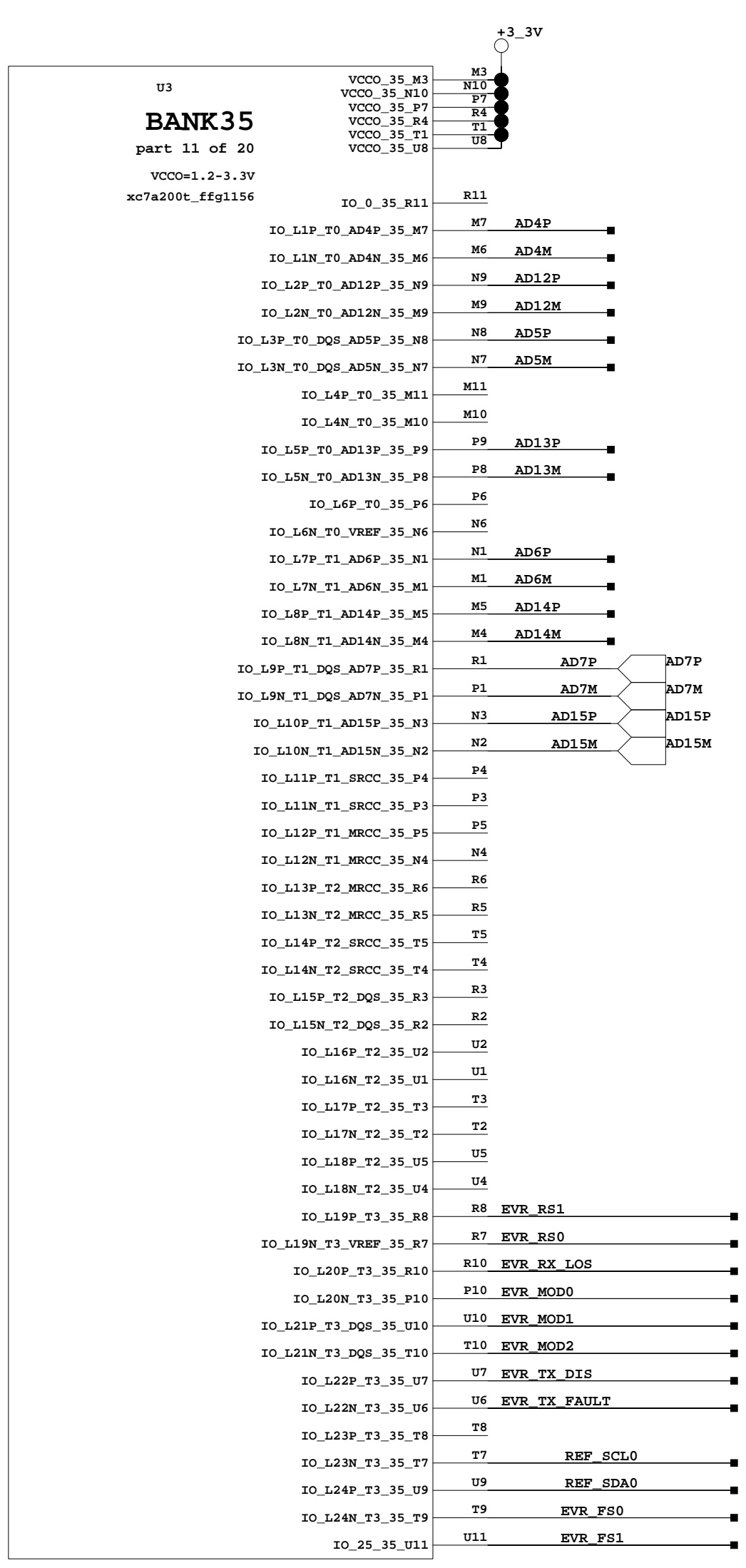
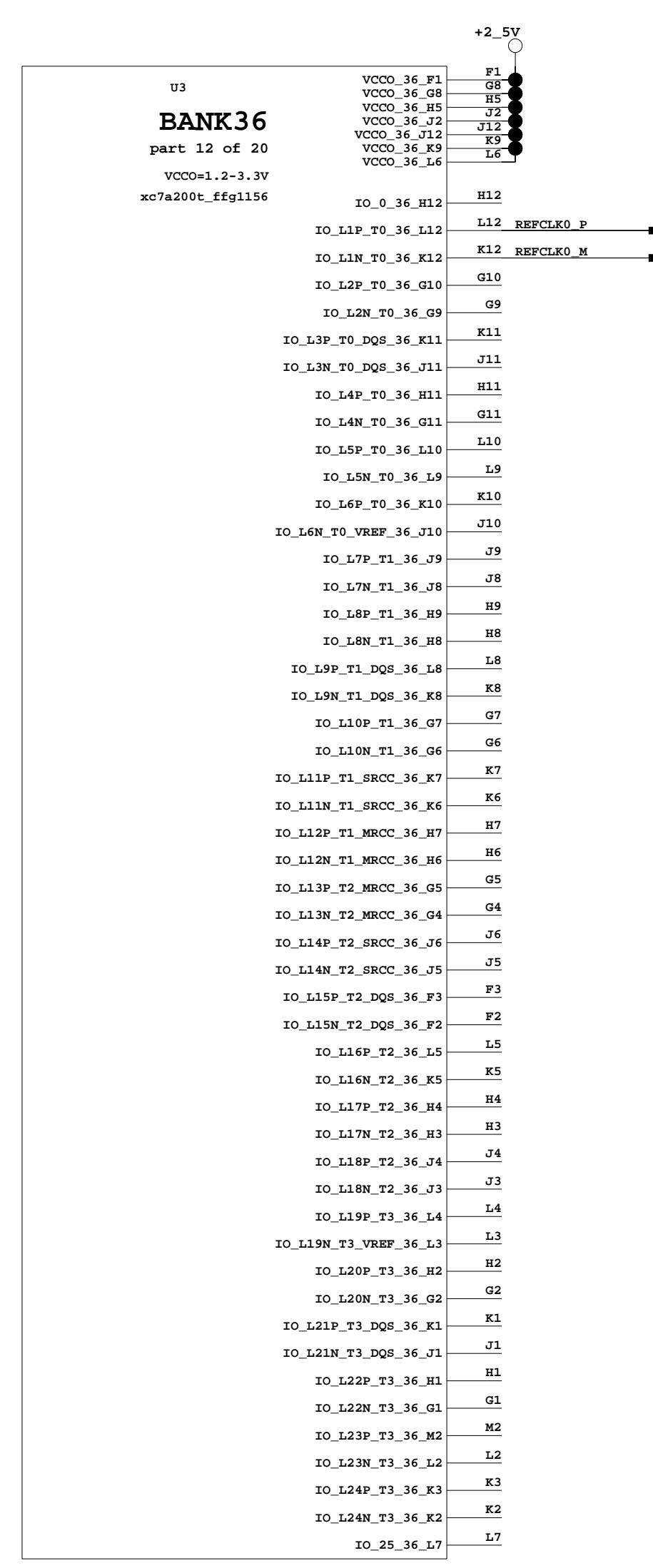

04/11/2013:10:36

SLAC NATIONAL ACCELERATOR LABORATORY U.S. DEPARTMENT OF ENERGY STANFORD UNIVERSITY STANFORD, CALIFORNIA		SHEET 3 OF 8
PROPRIETARY DATA OF STANFORD UNIVERSITY AND/OR U.S. DEPARTMENT OF ENERGY. RECIPIENT SHALL NOT PUBLISH THE INFORMATION WITHIN UNLESS GRANTED SPECIFIC PERMISSION OF STANFORD UNIVERSITY.		GPG CARD Generation 3 EVR Block
ENR Larry Ruckman DFR CDR	DATE 2013 APPROVALS	LOCATED AT SHEET 1 SD-260-101-03-C00



U3  
part 19 of 20  
xc7a200t\_ffgl156

A1	GND_A1	
A2	GND_A2	
A3	GND_A3	
A4	GND_A4	
A5	GND_A5	
A6	GND_A6	
A7	GND_A7	
A8	GND_A8	
A9	GND_A9	
A10	GND_A10	
A11	GND_A11	
A12	GND_A12	
A13	GND_A13	
A14	GND_A14	
A15	GND_A15	
A16	GND_A16	
A17	GND_A17	
A18	GND_A18	
A19	GND_A19	
A20	GND_A20	
A21	GND_A21	
A22	GND_A22	
A23	GND_A23	
A24	GND_A24	
A25	GND_A25	
A26	GND_A26	
A27	GND_A27	
A28	GND_A28	
A29	GND_A29	
A30	GND_A30	
A31	GND_A31	
A32	GND_A32	
A33	GND_A33	
A34	GND_A34	
A35	GND_A35	
A36	GND_A36	
A37	GND_A37	
A38	GND_A38	
A39	GND_A39	
A40	GND_A40	
A41	GND_A41	
A42	GND_A42	
A43	GND_A43	
A44	GND_A44	
A45	GND_A45	
A46	GND_A46	
A47	GND_A47	
A48	GND_A48	
A49	GND_A49	
A50	GND_A50	
A51	GND_A51	
A52	GND_A52	
A53	GND_A53	
A54	GND_A54	
A55	GND_A55	
A56	GND_A56	
A57	GND_A57	
A58	GND_A58	
A59	GND_A59	
A60	GND_A60	
A61	GND_A61	
A62	GND_A62	
A63	GND_A63	
A64	GND_A64	
A65	GND_A65	
A66	GND_A66	
A67	GND_A67	
A68	GND_A68	
A69	GND_A69	
A70	GND_A70	
A71	GND_A71	
A72	GND_A72	
A73	GND_A73	
A74	GND_A74	
A75	GND_A75	
A76	GND_A76	
A77	GND_A77	
A78	GND_A78	
A79	GND_A79	
A80	GND_A80	
A81	GND_A81	
A82	GND_A82	
A83	GND_A83	
A84	GND_A84	
A85	GND_A85	
A86	GND_A86	
A87	GND_A87	
A88	GND_A88	
A89	GND_A89	
A90	GND_A90	
A91	GND_A91	
A92	GND_A92	
A93	GND_A93	
A94	GND_A94	
A95	GND_A95	
A96	GND_A96	
A97	GND_A97	
A98	GND_A98	
A99	GND_A99	
A100	GND_A100	

U3  
part 20 of 20  
xc7a200t\_ffgl156

K14	VCCINT_E14	
K15	VCCINT_E15	
K16	VCCINT_E16	
K17	VCCINT_E17	
K18	VCCINT_E18	
K19	VCCINT_E19	
K20	VCCINT_E20	
K21	VCCINT_E21	
K22	VCCINT_E22	
K23	VCCINT_E23	
K24	VCCINT_E24	
K25	VCCINT_E25	
K26	VCCINT_E26	
K27	VCCINT_E27	
K28	VCCINT_E28	
K29	VCCINT_E29	
K30	VCCINT_E30	
K31	VCCINT_E31	
K32	VCCINT_E32	
K33	VCCINT_E33	
K34	VCCINT_E34	
K35	VCCINT_E35	
K36	VCCINT_E36	
K37	VCCINT_E37	
K38	VCCINT_E38	
K39	VCCINT_E39	
K40	VCCINT_E40	
K41	VCCINT_E41	
K42	VCCINT_E42	
K43	VCCINT_E43	
K44	VCCINT_E44	
K45	VCCINT_E45	
K46	VCCINT_E46	
K47	VCCINT_E47	
K48	VCCINT_E48	
K49	VCCINT_E49	
K50	VCCINT_E50	
K51	VCCINT_E51	
K52	VCCINT_E52	
K53	VCCINT_E53	
K54	VCCINT_E54	
K55	VCCINT_E55	
K56	VCCINT_E56	
K57	VCCINT_E57	
K58	VCCINT_E58	
K59	VCCINT_E59	
K60	VCCINT_E60	
K61	VCCINT_E61	
K62	VCCINT_E62	
K63	VCCINT_E63	
K64	VCCINT_E64	
K65	VCCINT_E65	
K66	VCCINT_E66	
K67	VCCINT_E67	
K68	VCCINT_E68	
K69	VCCINT_E69	
K70	VCCINT_E70	
K71	VCCINT_E71	
K72	VCCINT_E72	
K73	VCCINT_E73	
K74	VCCINT_E74	
K75	VCCINT_E75	
K76	VCCINT_E76	
K77	VCCINT_E77	
K78	VCCINT_E78	
K79	VCCINT_E79	
K80	VCCINT_E80	
K81	VCCINT_E81	
K82	VCCINT_E82	
K83	VCCINT_E83	
K84	VCCINT_E84	
K85	VCCINT_E85	
K86	VCCINT_E86	
K87	VCCINT_E87	
K88	VCCINT_E88	
K89	VCCINT_E89	
K90	VCCINT_E90	
K91	VCCINT_E91	
K92	VCCINT_E92	
K93	VCCINT_E93	
K94	VCCINT_E94	
K95	VCCINT_E95	
K96	VCCINT_E96	
K97	VCCINT_E97	
K98	VCCINT_E98	
K99	VCCINT_E99	
K100	VCCINT_E100	

U3  
part 18 of 20  
xc7a200t\_ffgl156

M20	VCCBRAM_M20	
M21	VCCBRAM_M21	
M22	VCCBRAM_M22	
M23	VCCBRAM_M23	
M24	VCCBRAM_M24	
M25	VCCBRAM_M25	
M26	VCCBRAM_M26	
M27	VCCBRAM_M27	
M28	VCCBRAM_M28	
M29	VCCBRAM_M29	
M30	VCCBRAM_M30	
M31	VCCBRAM_M31	
M32	VCCBRAM_M32	
M33	VCCBRAM_M33	
M34	VCCBRAM_M34	
M35	VCCBRAM_M35	
M36	VCCBRAM_M36	
M37	VCCBRAM_M37	
M38	VCCBRAM_M38	
M39	VCCBRAM_M39	
M40	VCCBRAM_M40	
M41	VCCBRAM_M41	
M42	VCCBRAM_M42	
M43	VCCBRAM_M43	
M44	VCCBRAM_M44	
M45	VCCBRAM_M45	
M46	VCCBRAM_M46	
M47	VCCBRAM_M47	
M48	VCCBRAM_M48	
M49	VCCBRAM_M49	
M50	VCCBRAM_M50	
M51	VCCBRAM_M51	
M52	VCCBRAM_M52	
M53	VCCBRAM_M53	
M54	VCCBRAM_M54	
M55	VCCBRAM_M55	
M56	VCCBRAM_M56	
M57	VCCBRAM_M57	
M58	VCCBRAM_M58	
M59	VCCBRAM_M59	
M60	VCCBRAM_M60	
M61	VCCBRAM_M61	
M62	VCCBRAM_M62	
M63	VCCBRAM_M63	
M64	VCCBRAM_M64	
M65	VCCBRAM_M65	
M66	VCCBRAM_M66	
M67	VCCBRAM_M67	
M68	VCCBRAM_M68	
M69	VCCBRAM_M69	
M70	VCCBRAM_M70	
M71	VCCBRAM_M71	
M72	VCCBRAM_M72	
M73	VCCBRAM_M73	
M74	VCCBRAM_M74	
M75	VCCBRAM_M75	
M76	VCCBRAM_M76	
M77	VCCBRAM_M77	
M78	VCCBRAM_M78	
M79	VCCBRAM_M79	
M80	VCCBRAM_M80	
M81	VCCBRAM_M81	
M82	VCCBRAM_M82	
M83	VCCBRAM_M83	
M84	VCCBRAM_M84	
M85	VCCBRAM_M85	
M86	VCCBRAM_M86	
M87	VCCBRAM_M87	
M88	VCCBRAM_M88	
M89	VCCBRAM_M89	
M90	VCCBRAM_M90	
M91	VCCBRAM_M91	
M92	VCCBRAM_M92	
M93	VCCBRAM_M93	
M94	VCCBRAM_M94	
M95	VCCBRAM_M95	
M96	VCCBRAM_M96	
M97	VCCBRAM_M97	
M98	VCCBRAM_M98	
M99	VCCBRAM_M99	
M100	VCCBRAM_M100	

U3  
part 18 of 20  
xc7a200t\_ffgl156

AJ22	MGTREF_P13_AJ22	
AJ23	MGTREF_P13_AJ23	
AJ24	MGTREF_P13_AJ24	
AJ25	MGTREF_P13_AJ25	
AJ26	MGTREF_P13_AJ26	
AJ27	MGTREF_P13_AJ27	
AJ28	MGTREF_P13_AJ28	
AJ29	MGTREF_P13_AJ29	
AJ30	MGTREF_P13_AJ30	
AJ31	MGTREF_P13_AJ31	
AJ32	MGTREF_P13_AJ32	
AJ33	MGTREF_P13_AJ33	
AJ34	MGTREF_P13_AJ34	
AJ35	MGTREF_P13_AJ35	
AJ36	MGTREF_P13_AJ36	
AJ37	MGTREF_P13_AJ37	
AJ38	MGTREF_P13_AJ38	
AJ39	MGTREF_P13_AJ39	
AJ40	MGTREF_P13_AJ40	
AJ41	MGTREF_P13_AJ41	
AJ42	MGTREF_P13_AJ42	
AJ43	MGTREF_P13_AJ43	
AJ44	MGTREF_P13_AJ44	
AJ45	MGTREF_P13_AJ45	
AJ46	MGTREF_P13_AJ46	
AJ47	MGTREF_P13_AJ47	
AJ48	MGTREF_P13_AJ48	
AJ49	MGTREF_P13_AJ49	
AJ50	MGTREF_P13_AJ50	
AJ51	MGTREF_P13_AJ51	
AJ52	MGTREF_P13_AJ52	
AJ53	MGTREF_P13_AJ53	
AJ54	MGTREF_P13_AJ54	
AJ55	MGTREF_P13_AJ55	
AJ56	MGTREF_P13_AJ56	
AJ57	MGTREF_P13_AJ57	
AJ58	MGTREF_P13_AJ58	
AJ59	MGTREF_P13_AJ59	
AJ60	MGTREF_P13_AJ60	
AJ61	MGTREF_P13_AJ61	
AJ62	MGTREF_P13_AJ62	
AJ63	MGTREF_P13_AJ63	
AJ64	MGTREF_P13_AJ64	
AJ65	MGTREF_P13_AJ65	
AJ66	MGTREF_P13_AJ66	
AJ67	MGTREF_P13_AJ67	
AJ68	MGTREF_P13_AJ68	
AJ69	MGTREF_P13_AJ69	
AJ70	MGTREF_P13_AJ70	
AJ71	MGTREF_P13_AJ71	
AJ72	MGTREF_P13_AJ72	
AJ73	MGTREF_P13_AJ73	
AJ74	MGTREF_P13_AJ74	
AJ75	MGTREF_P13_AJ75	
AJ76	MGTREF_P13_AJ76	
AJ77	MGTREF_P13_AJ77	
AJ78	MGTREF_P13_AJ78	
AJ79	MGTREF_P13_AJ79	
AJ80	MGTREF_P13_AJ80	
AJ81	MGTREF_P13_AJ81	
AJ82	MGTREF_P13_AJ82	
AJ83	MGTREF_P13_AJ83	
AJ84	MGTREF_P13_AJ84	
AJ85	MGTREF_P13_AJ85	
AJ86	MGTREF_P13_AJ86	
AJ87	MGTREF_P13_AJ87	
AJ88	MGTREF_P13_AJ88	
AJ89	MGTREF_P13_AJ89	
AJ90	MGTREF_P13_AJ90	
AJ91	MGTREF_P13_AJ91	
AJ92	MGTREF_P13_AJ92	
AJ93	MGTREF_P13_AJ93	
AJ94	MGTREF_P13_AJ94	
AJ95	MGTREF_P13_AJ95	
AJ96	MGTREF_P13_AJ96	
AJ97	MGTREF_P13_AJ97	
AJ98	MGTREF_P13_AJ98	
AJ99	MGTREF_P13_AJ99	
AJ100	MGTREF_P13_AJ100	

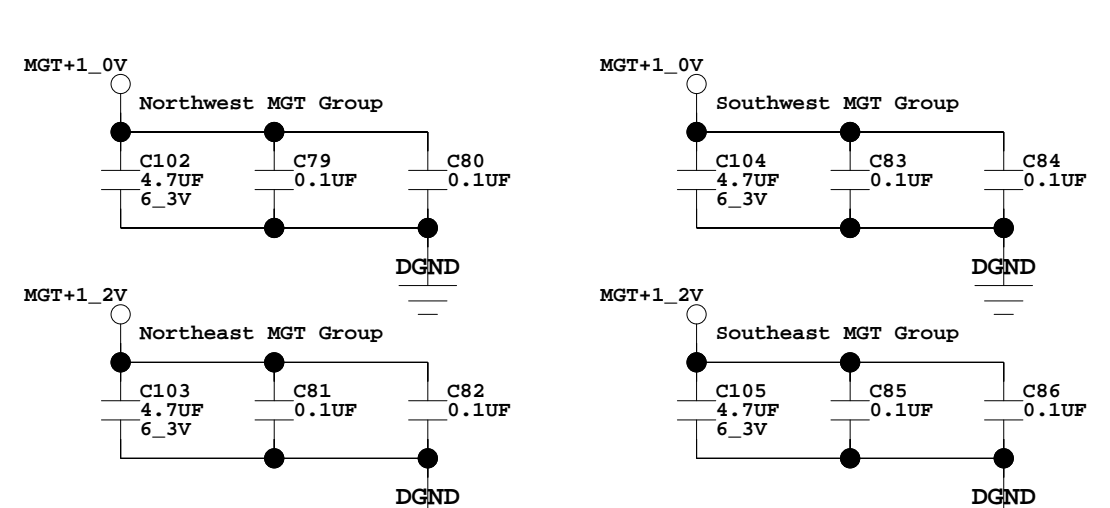
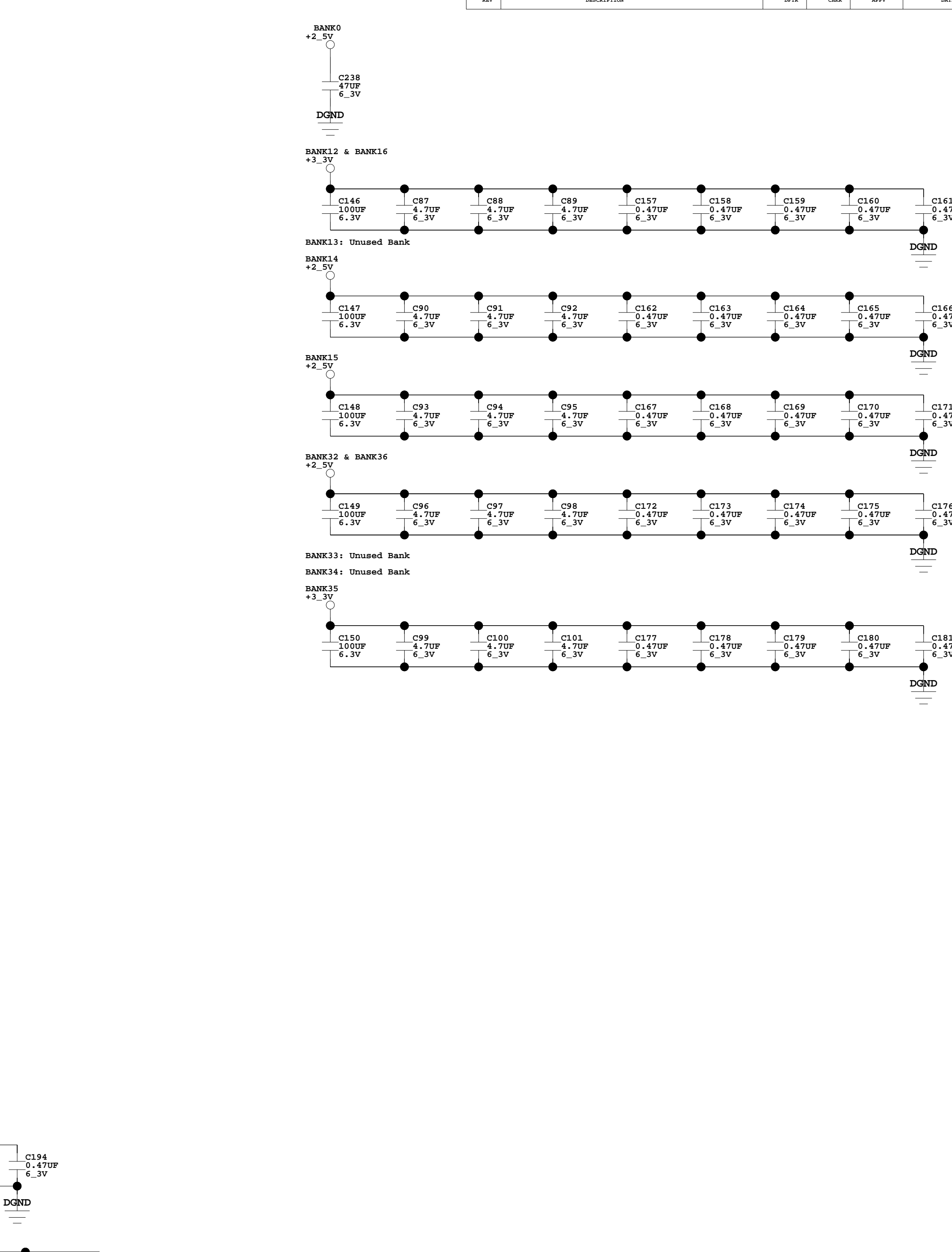
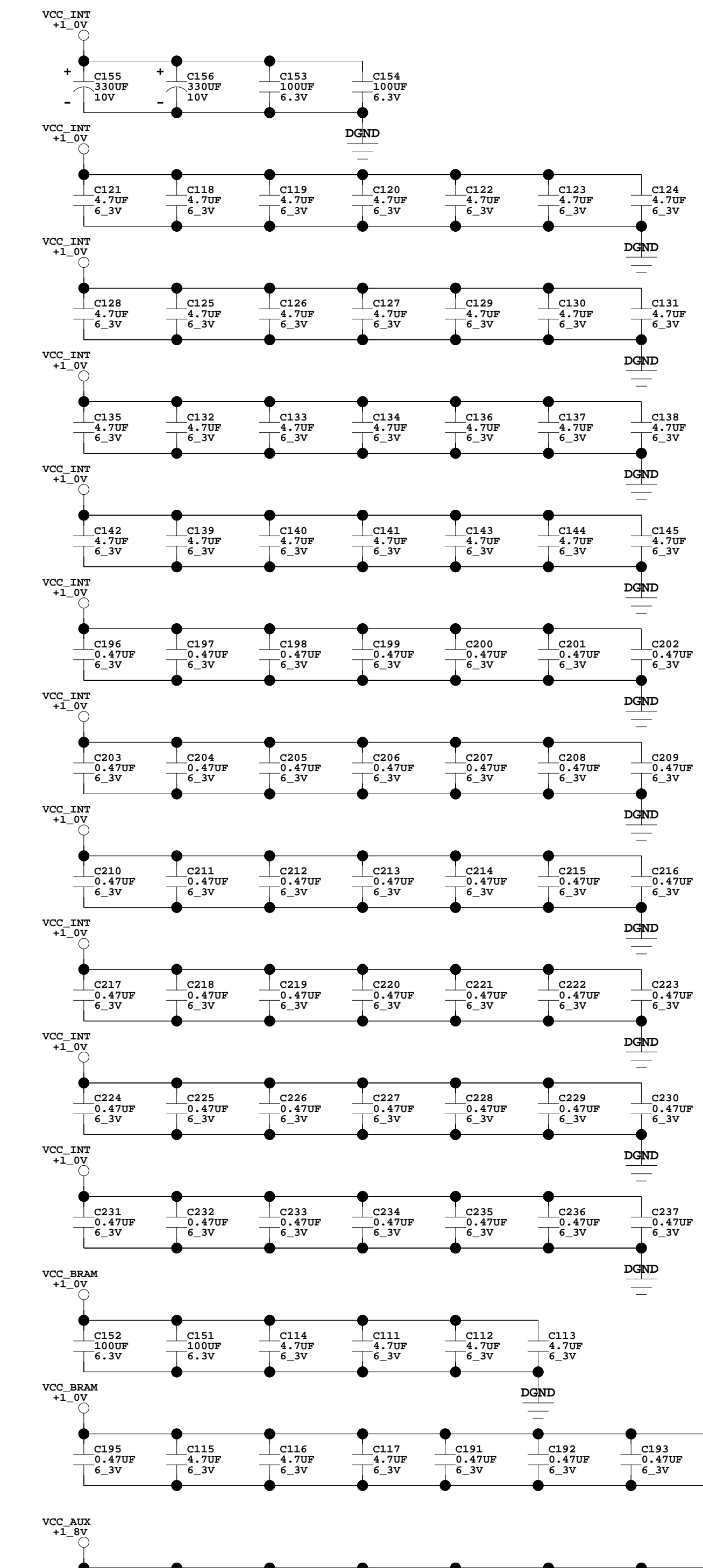

Place resistor close to FPGA input

04/11/2013:10:36

SLAC NATIONAL ACCELERATOR LABORATORY U.S. DEPARTMENT OF ENERGY		SHEET 6 OF 8
STANFORD UNIVERSITY STANFORD, CALIFORNIA		<b>FGP CARD Generation 3</b> <b>FPGA POWER Block</b>  LOCATED AT SHEET 1 SD-260-101-03-C00
PROPRIETARY DATA OF STANFORD UNIVERSITY AND/OR U.S. DEPARTMENT OF ENERGY. RECIPIENT SHALL NOT PUBLISH THE INFORMATION WITHIN UNLESS GRANTED SPECIFIC PERMISSION OF STANFORD UNIVERSITY.		
DATE 2013	APPROVALS Larry Ruckman	
OTHER INFORMATION		



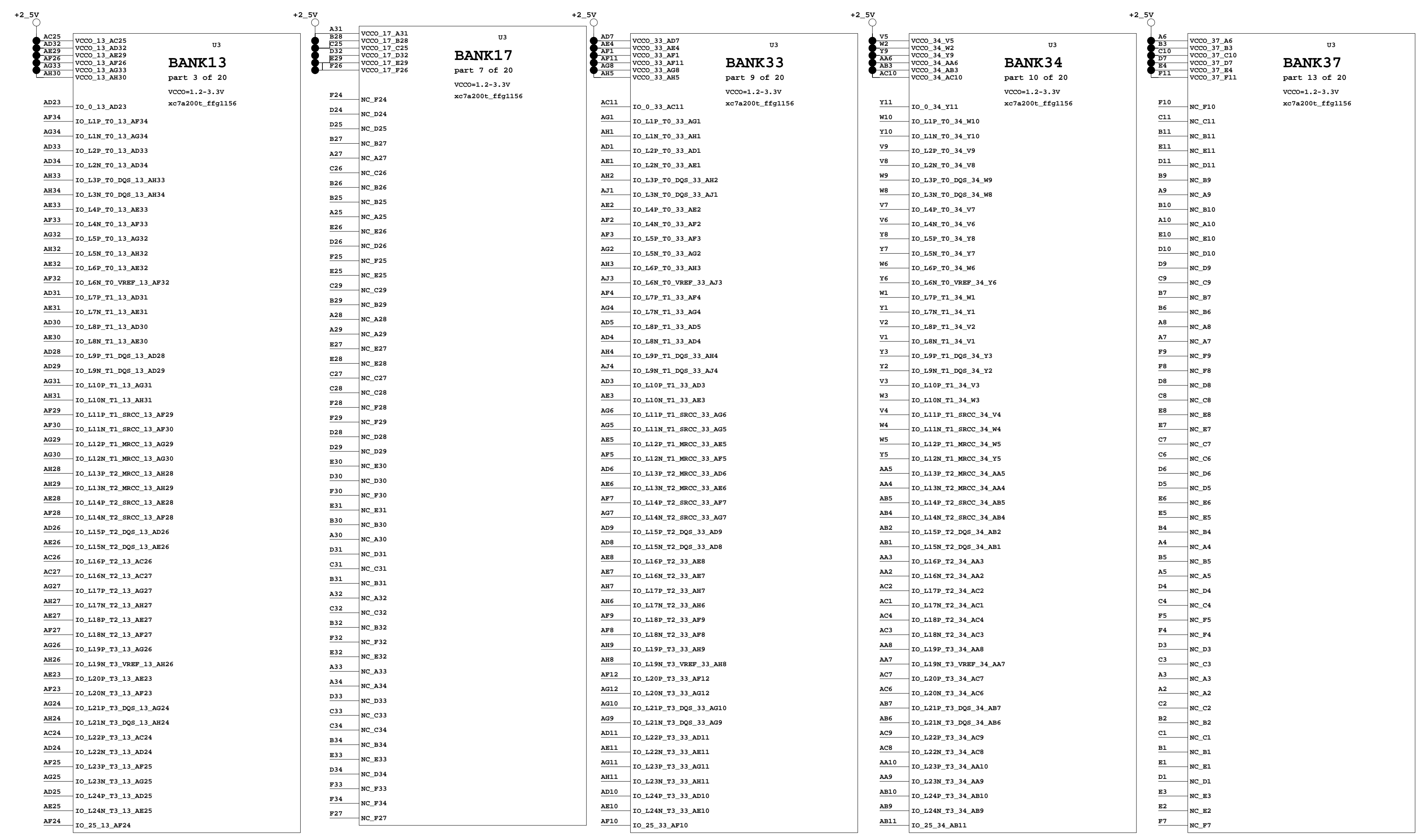

04/11/2013:10:36

SLAC NATIONAL ACCELERATOR LABORATORY U.S. DEPARTMENT OF ENERGY <small>STANFORD UNIVERSITY STANFORD, CALIFORNIA</small>		SHEET 5 OF 8								
PROPRIETARY DATA OF STANFORD UNIVERSITY AND/OR U.S. DEPARTMENT OF ENERGY. RECIPIENT SHALL NOT PUBLISH THE INFORMATION WITHIN UNLESS GRANTED SPECIFIC PERMISSION OF STANFORD UNIVERSITY.		FGP CARD Generation 3 FPGA UNUSED BANK Block								
<table border="1"> <thead> <tr> <th>DATE</th> <th>APPROVALS</th> </tr> </thead> <tbody> <tr> <td>2013</td> <td>Larry Ruckman</td> </tr> <tr> <td> </td> <td> </td> </tr> <tr> <td> </td> <td> </td> </tr> </tbody> </table>	DATE	APPROVALS	2013	Larry Ruckman					LOCATED AT SHEET 1 SD-260-101-03-C00	D
DATE	APPROVALS									
2013	Larry Ruckman									

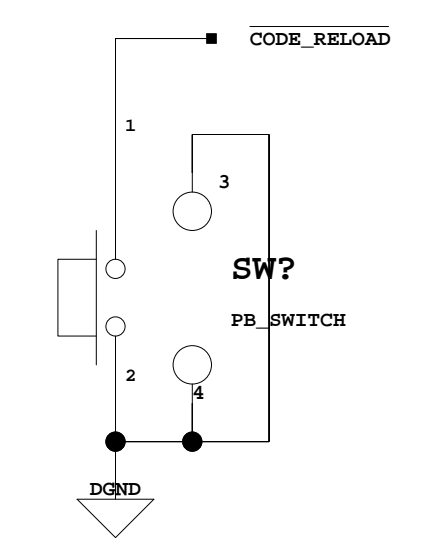
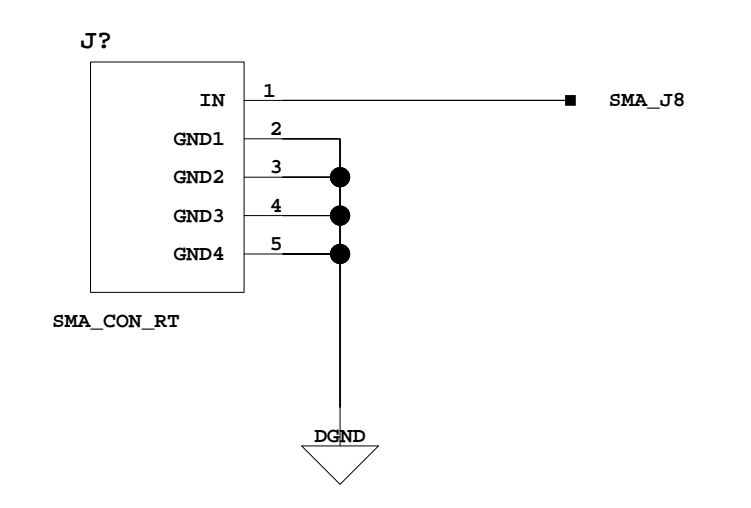
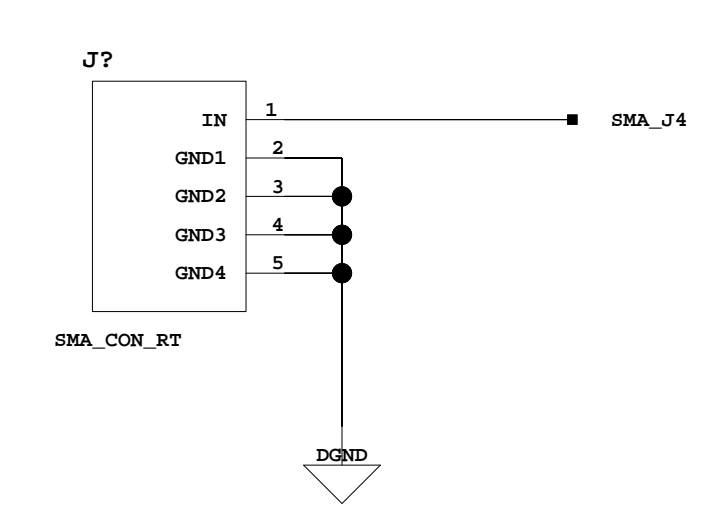
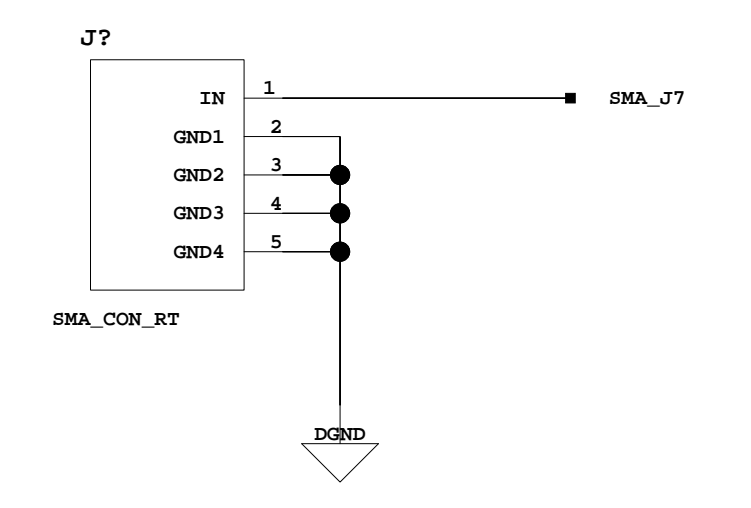
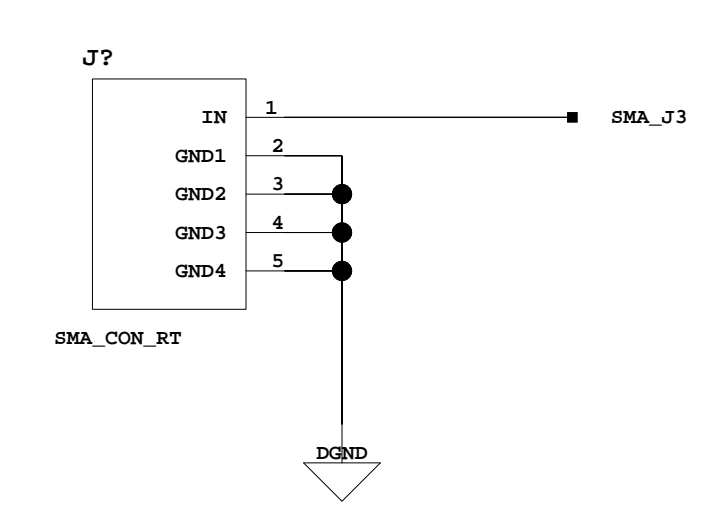
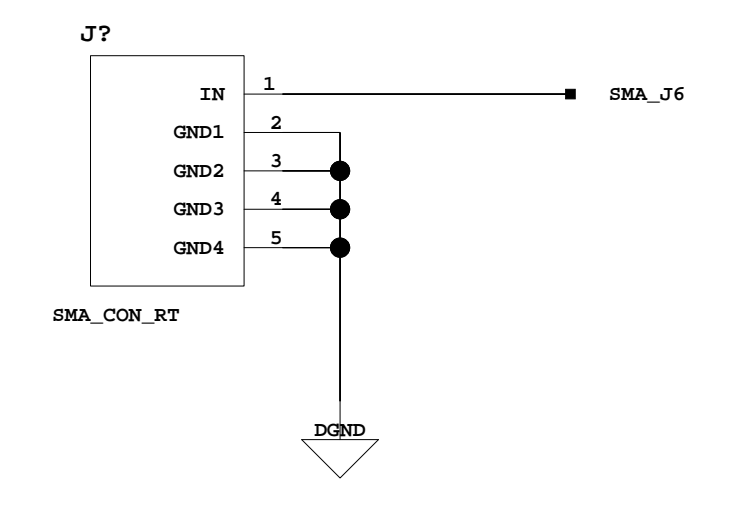
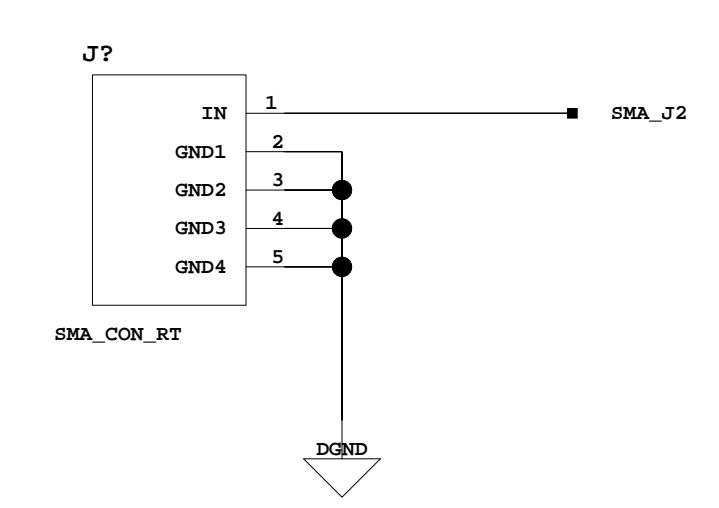
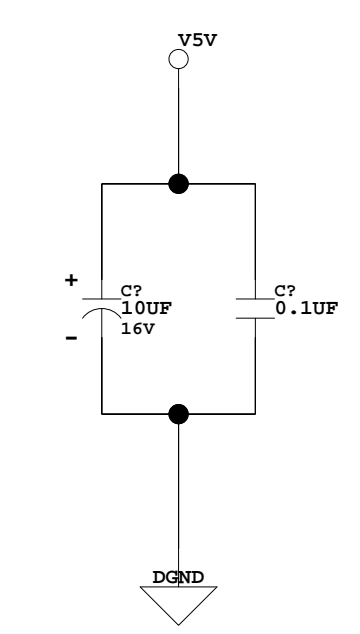
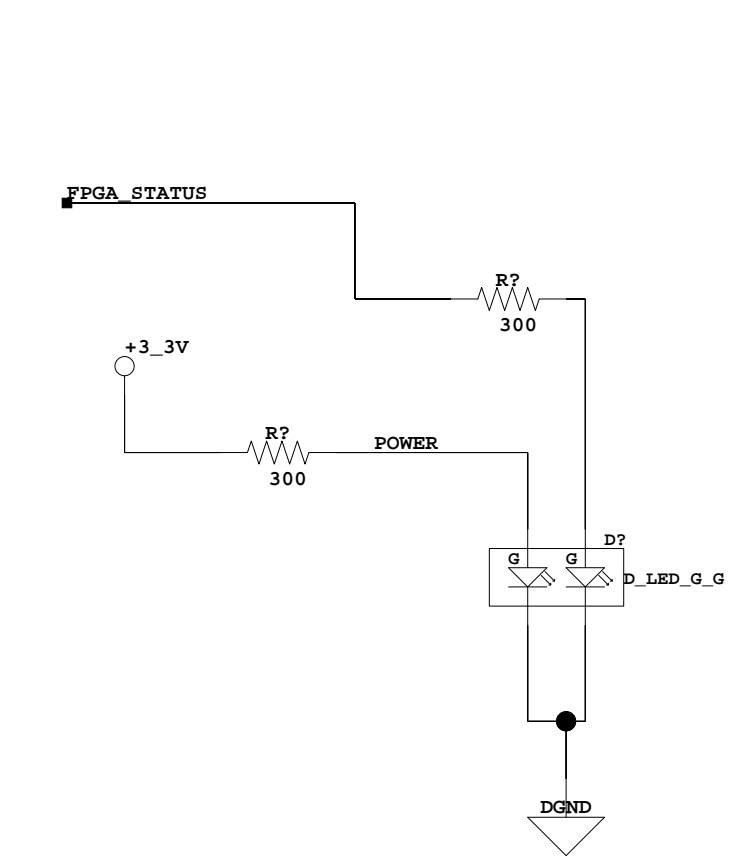
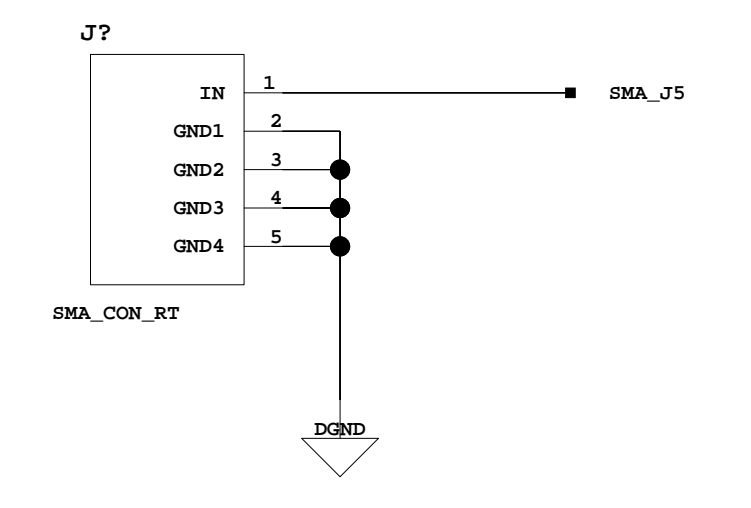
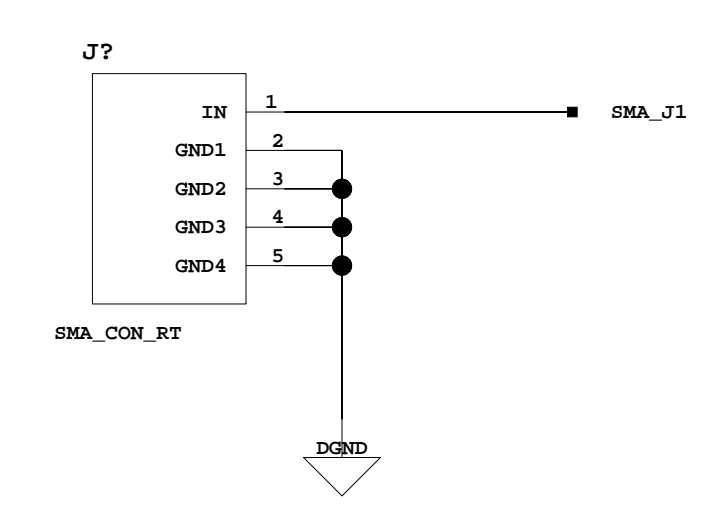
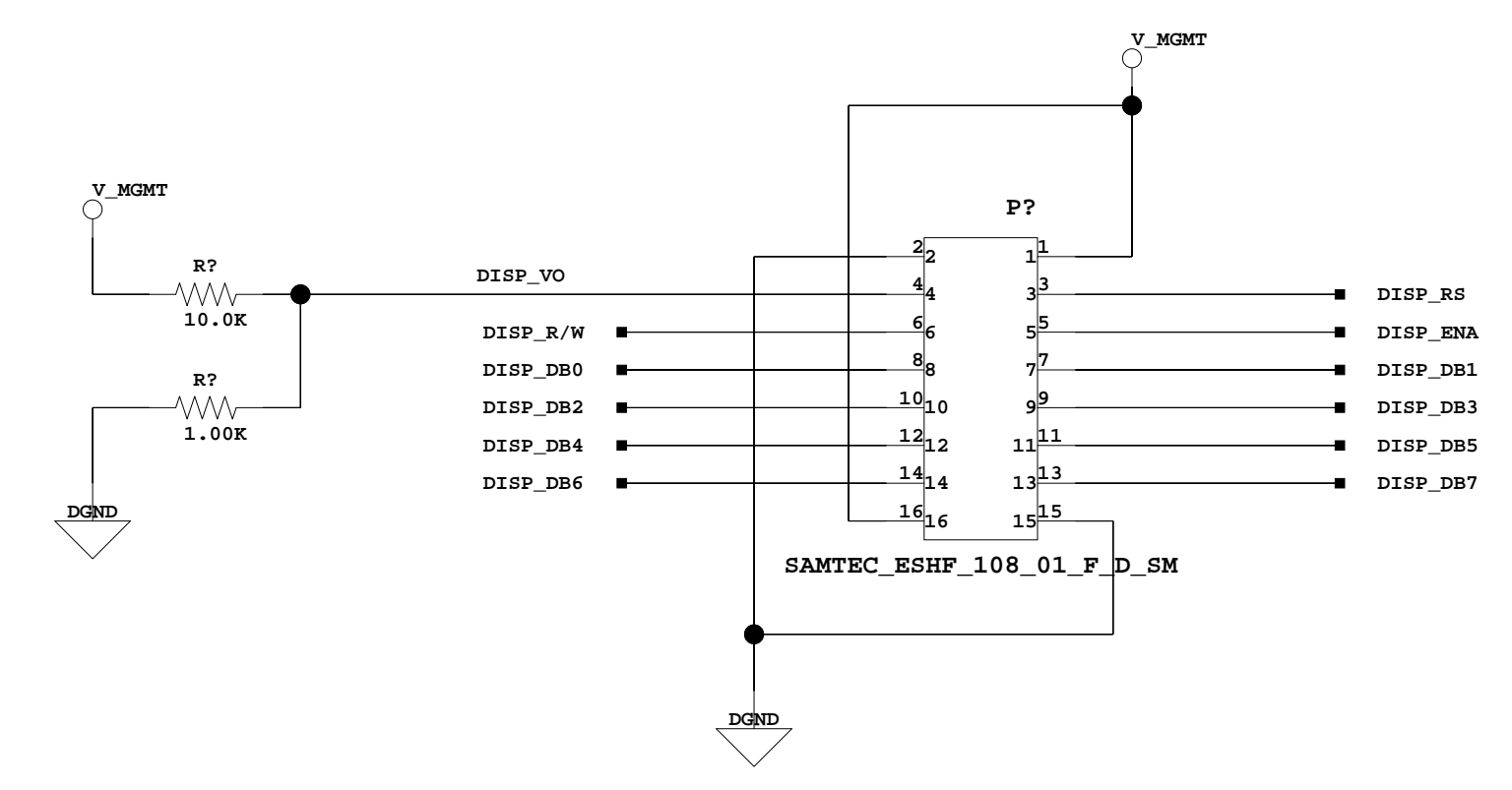
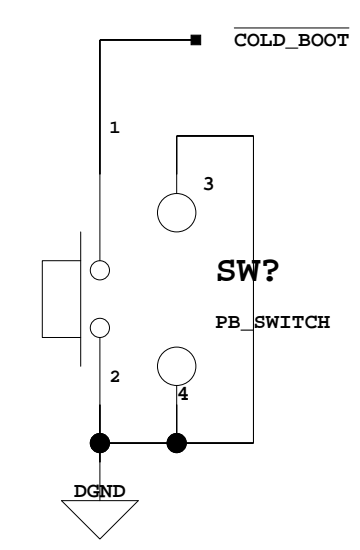

SMA\_J[8:1]

<b>SLAC NATIONAL ACCELERATOR LABORATORY</b> <b>U.S. DEPARTMENT OF ENERGY</b> <small>STANFORD UNIVERSITY STANFORD, CALIFORNIA</small>		
<small>PROPRIETARY DATA OF STANFORD UNIVERSITY AND/OR U.S. DEPARTMENT OF ENERGY. RECIPIENT SHALL NOT PUBLISH THE INFORMATION WITHIN UNLESS GRANTED SPECIFIC PERMISSION OF STANFORD UNIVERSITY.</small>		
ENGR	DATE	APPROVALS
DFTK		
CHKD		

<b>SHEET</b> <b>OF</b>  <b>SLAC</b>  <b>SD-</b>	<b>D</b>
---	----------

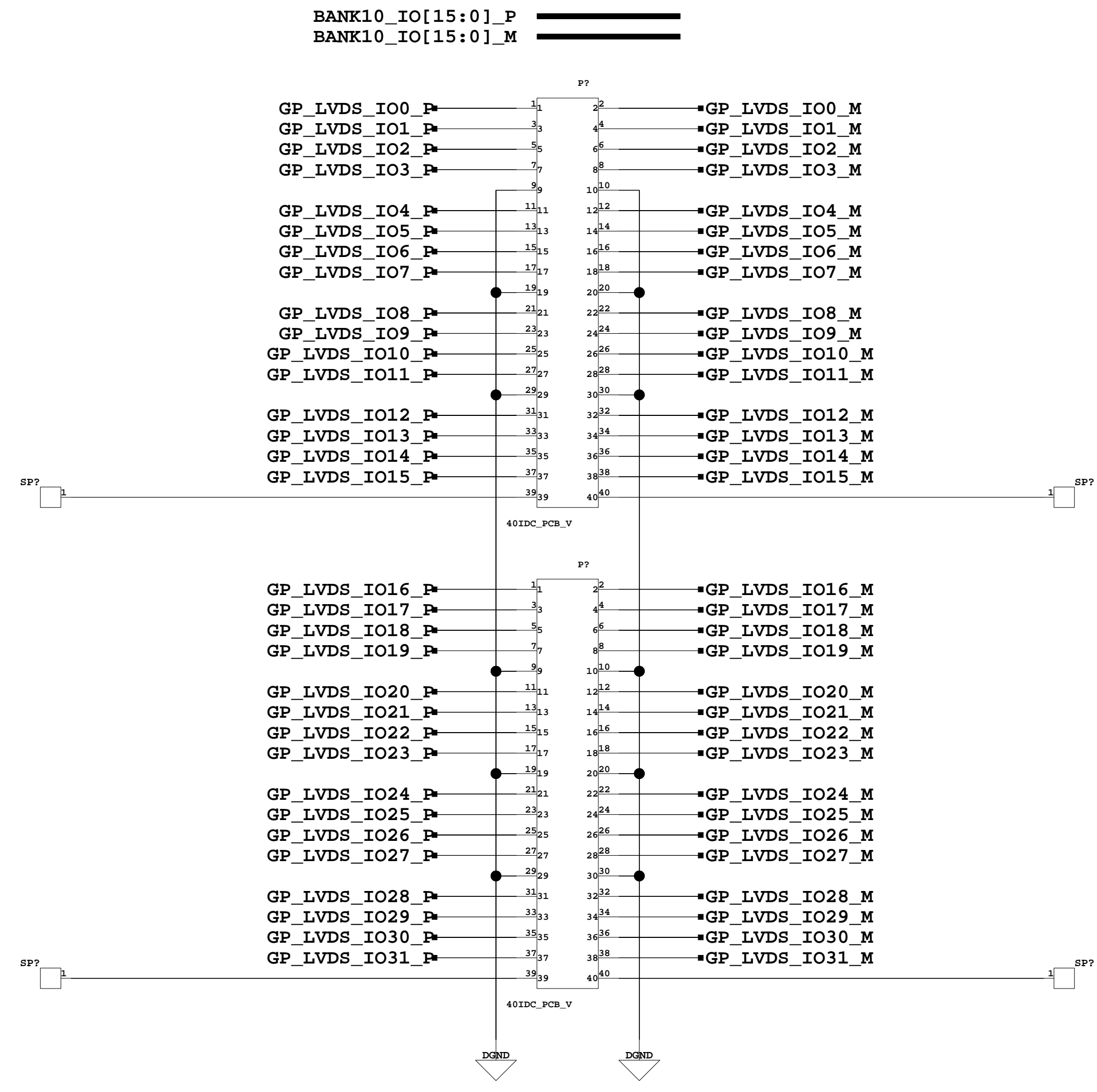

SLAC NATIONAL ACCELERATOR LABORATORY U.S. DEPARTMENT OF ENERGY		
STANFORD UNIVERSITY		STANFORD, CALIFORNIA
PROPRIETARY DATA OF STANFORD UNIVERSITY AND/OR U.S. DEPARTMENT OF ENERGY. RECIPIENT SHALL NOT PUBLISH THE INFORMATION WITHIN UNLESS GRANTED SPECIFIC PERMISSION OF STANFORD UNIVERSITY.		
ENR	DATE	APPROVALS

SHEET	OF
SLAC	
SD-	D

# NOTE: Not 10W slot Compatible

NOTE: PCI-E Hard IP core located in U3, and U3 group 216 (GIP\_X0V4, GIP\_X0V5, GIP\_X0V6, and GIP\_X0V7)

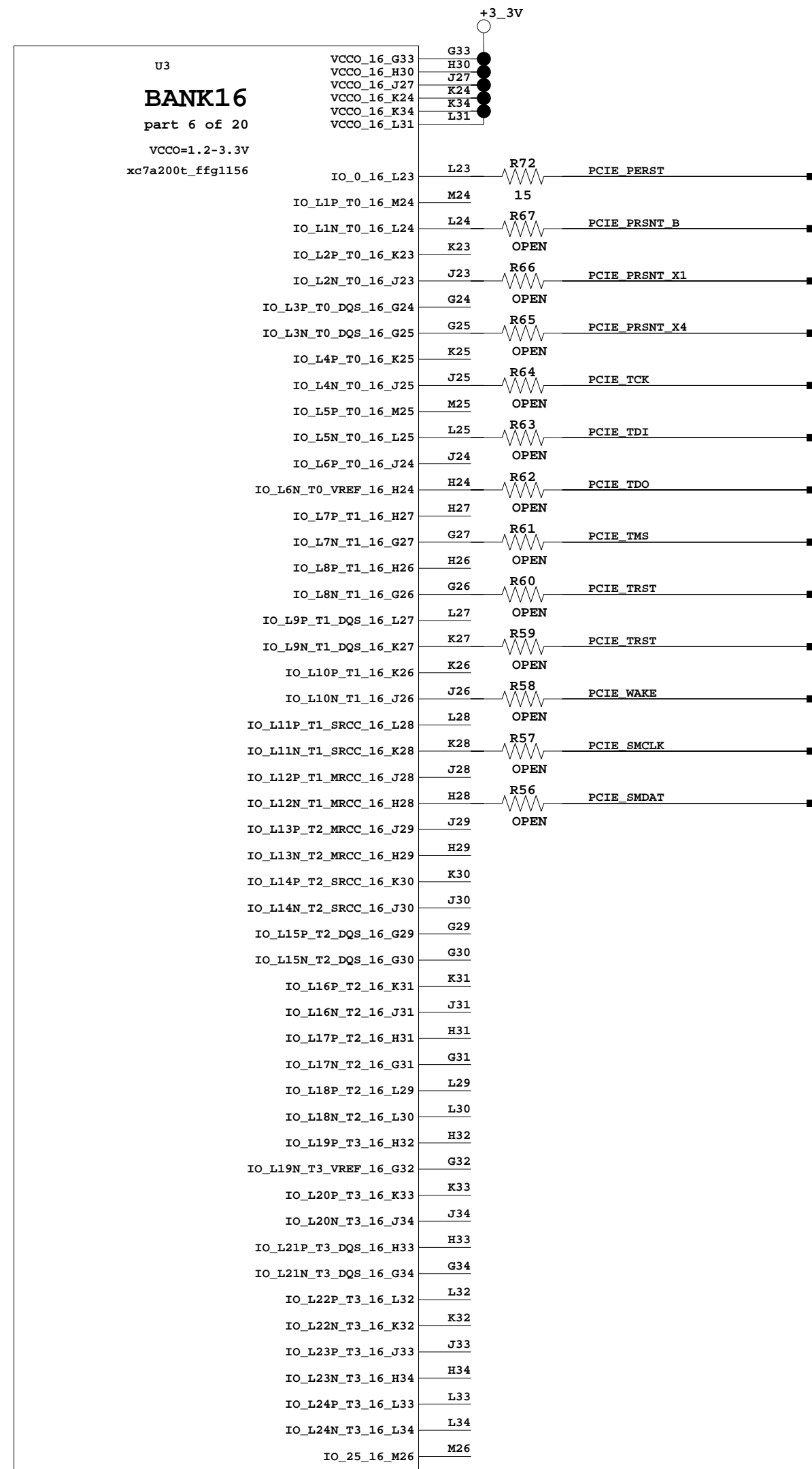
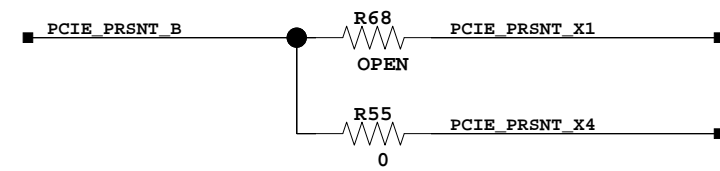
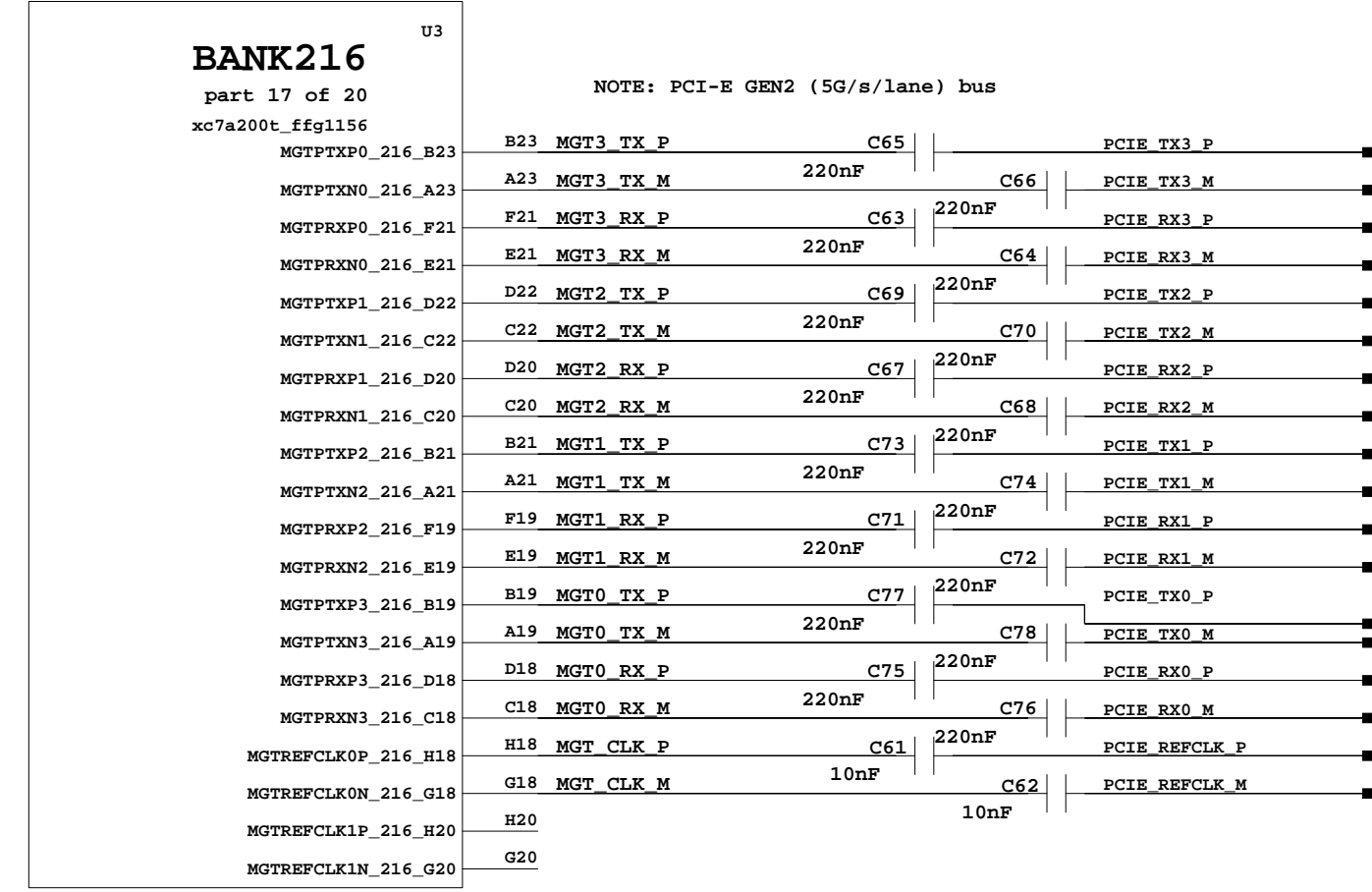

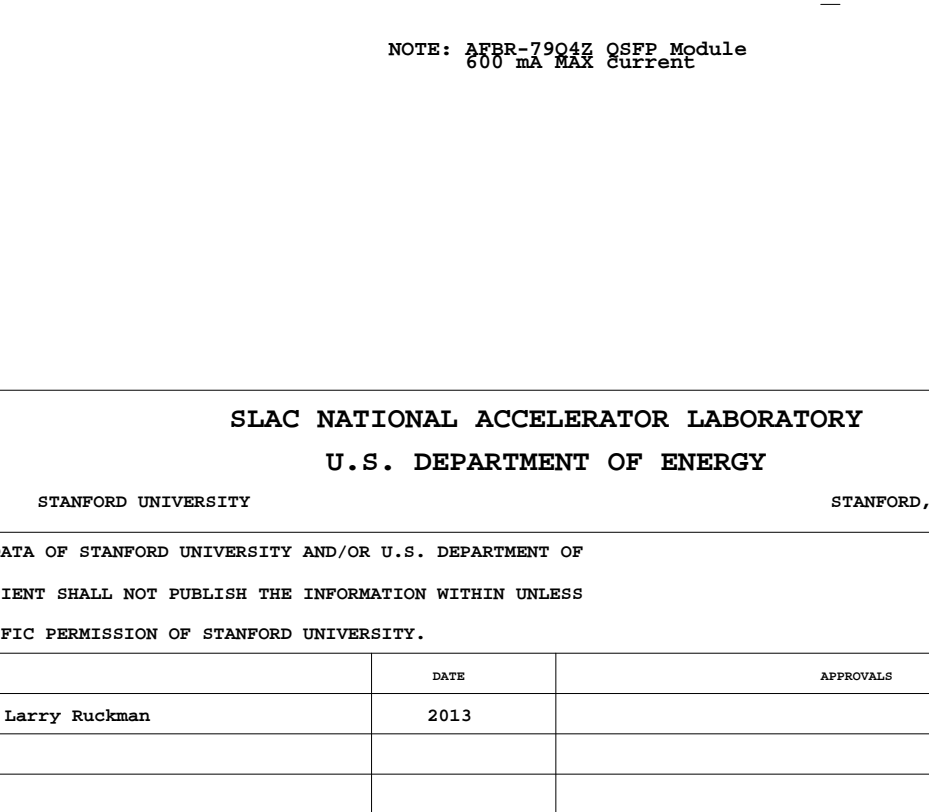
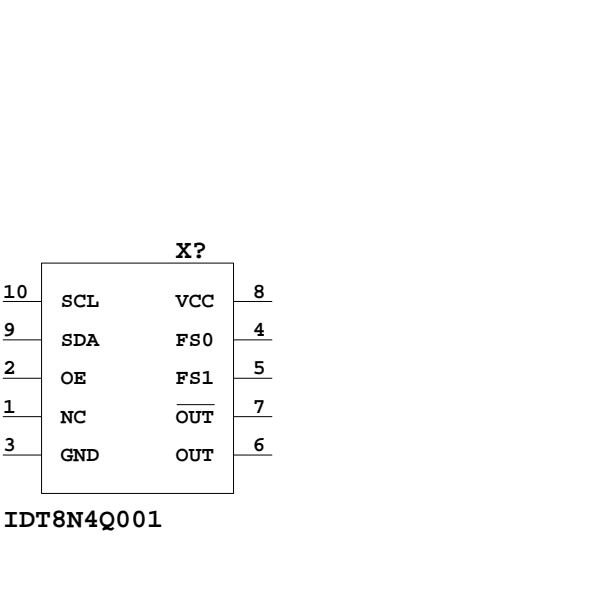
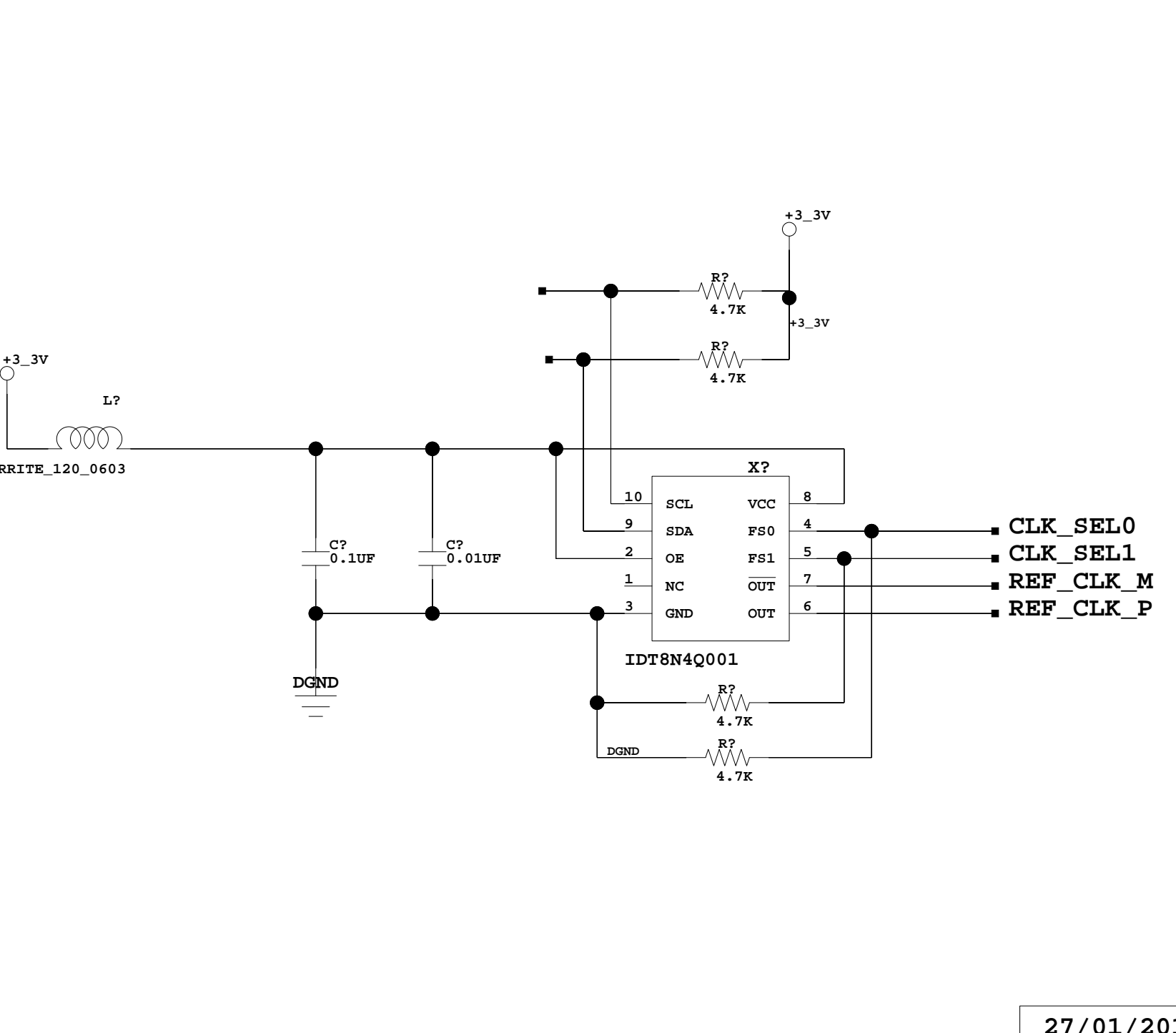
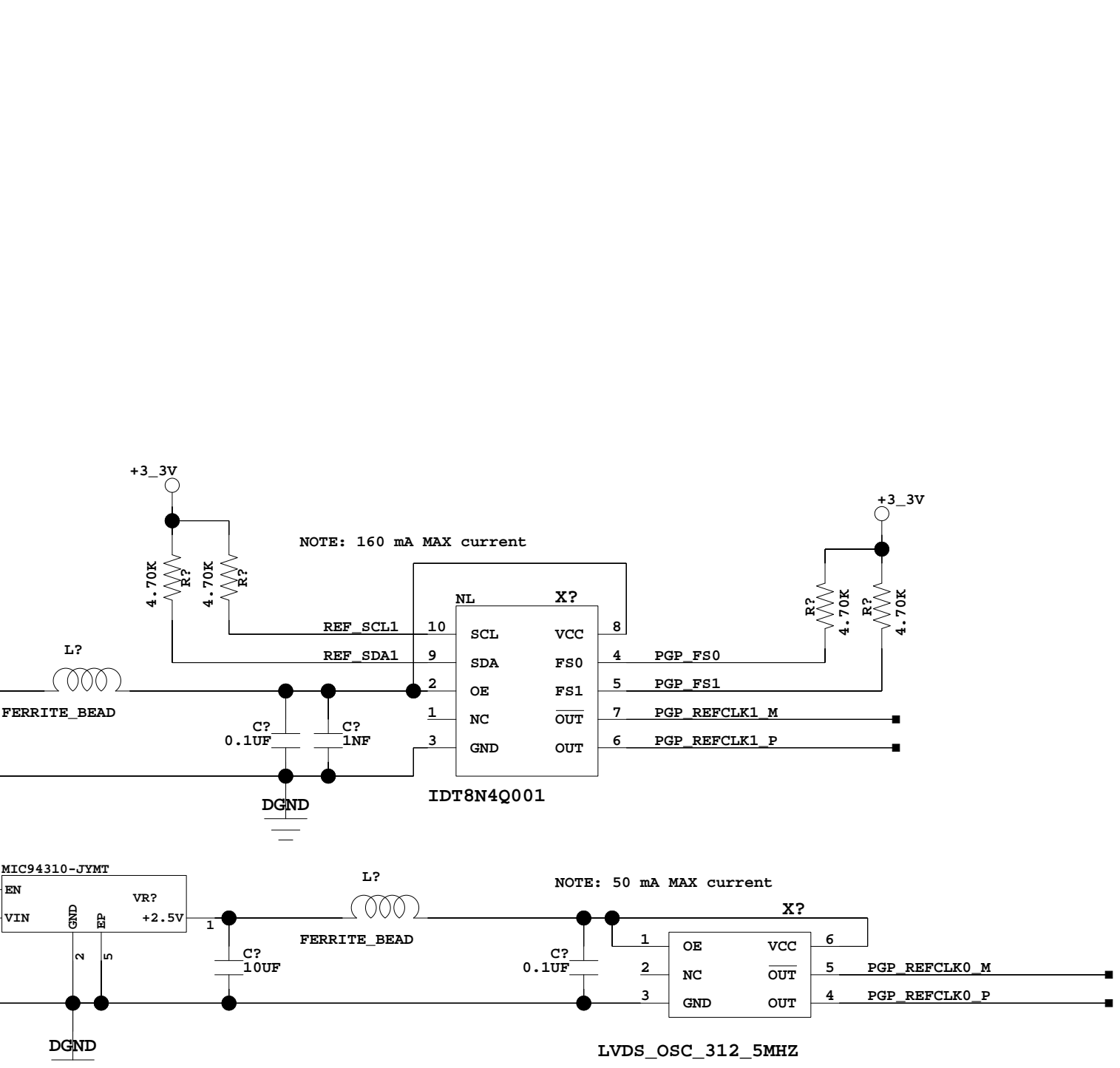
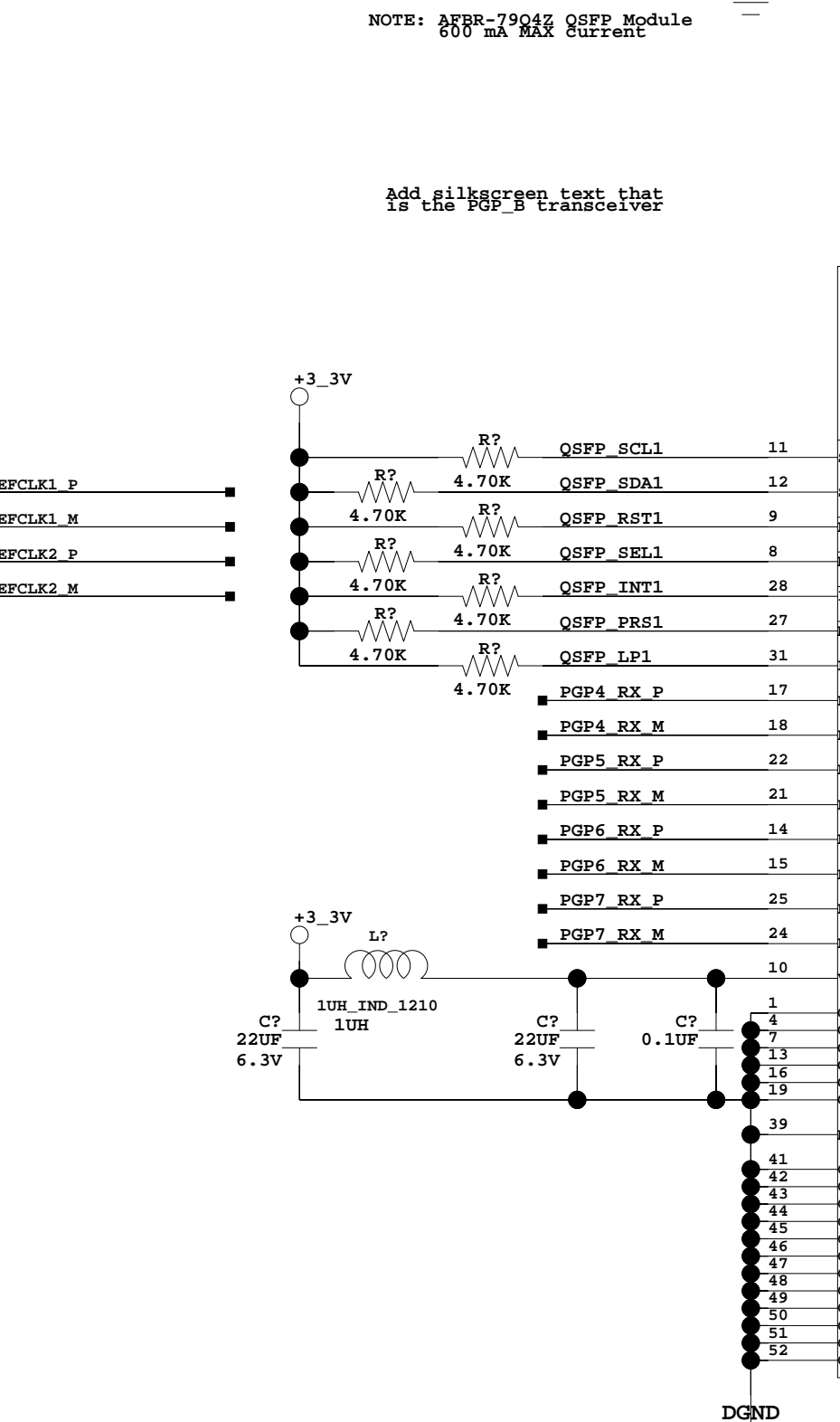
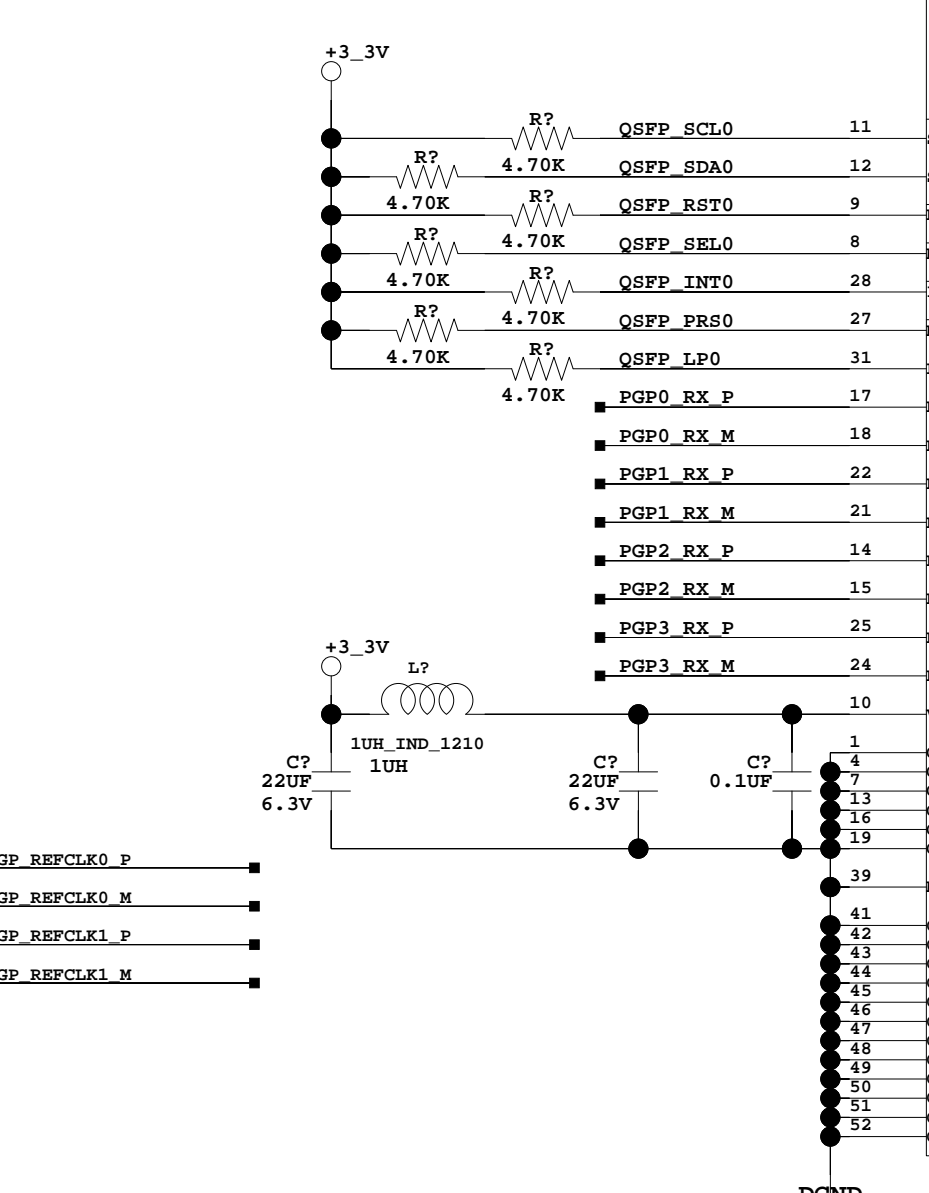
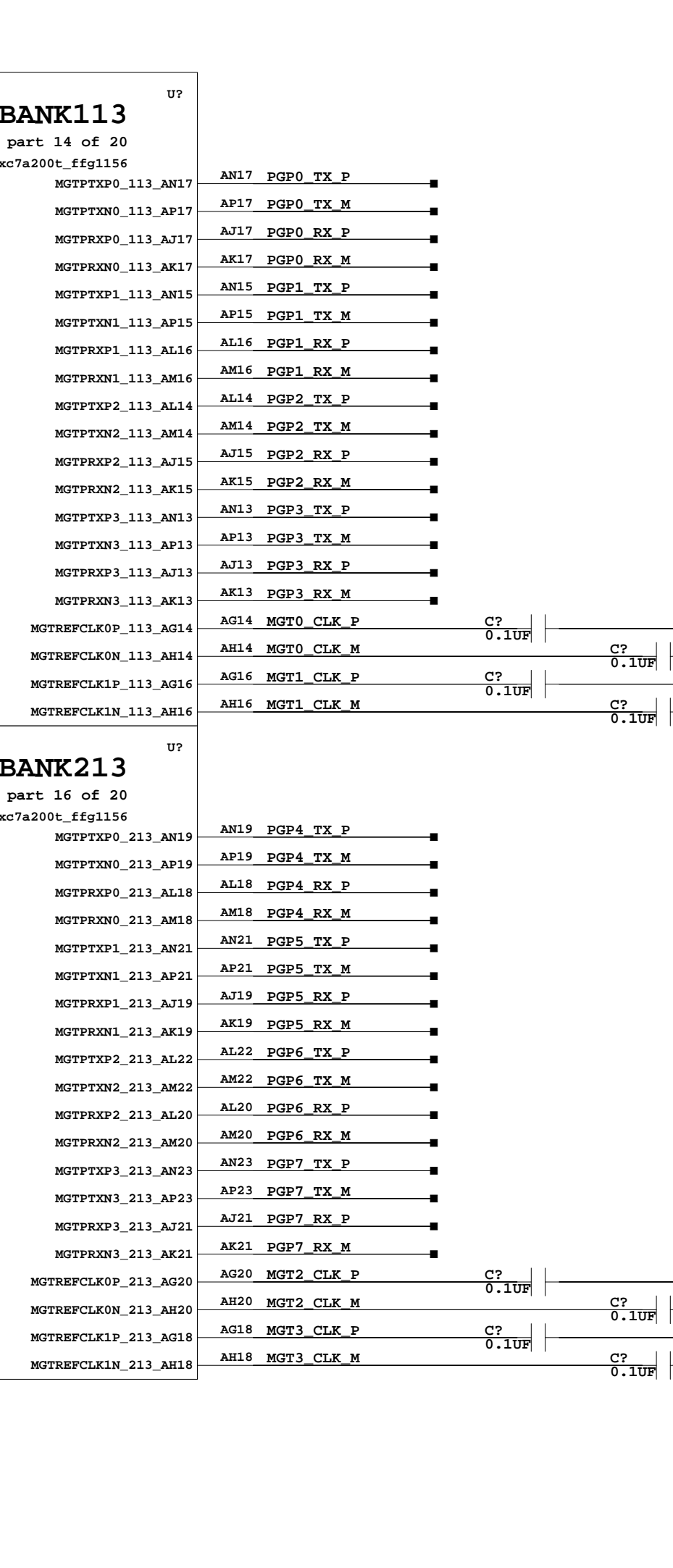
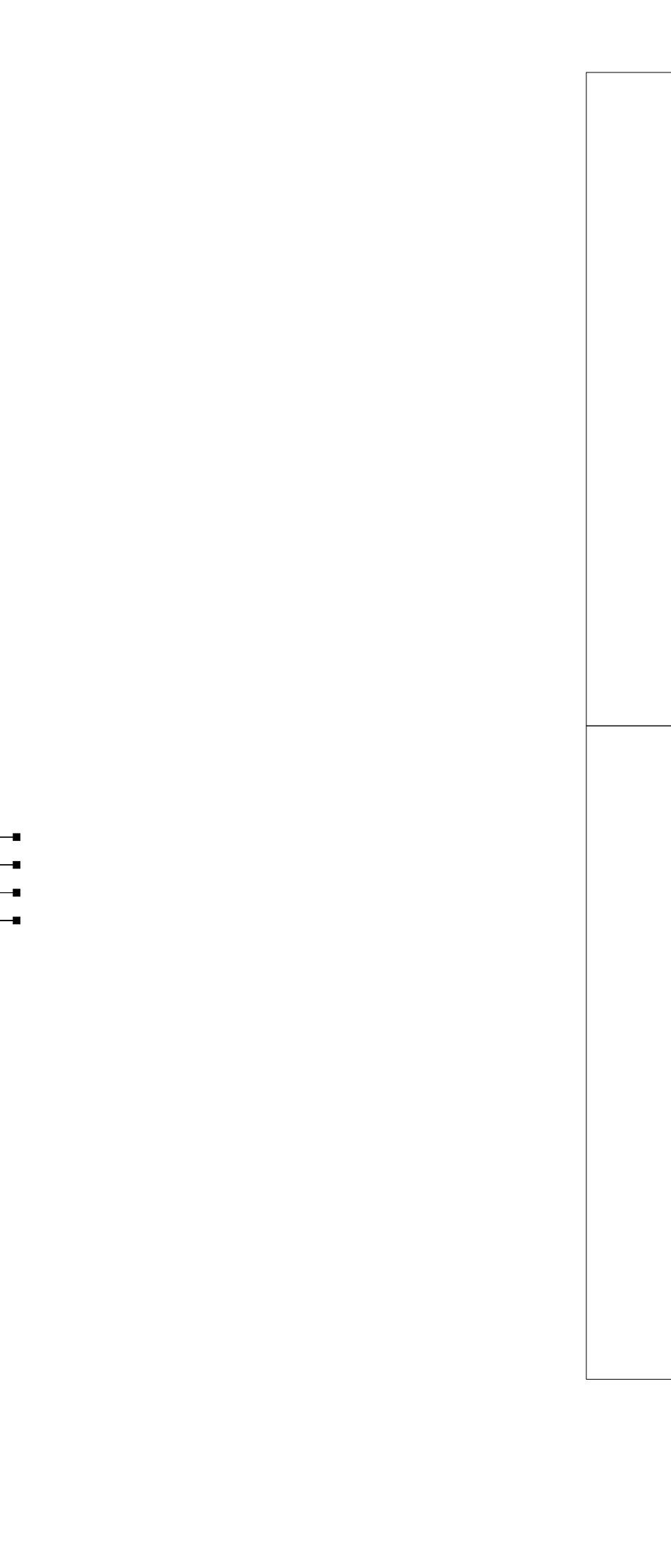
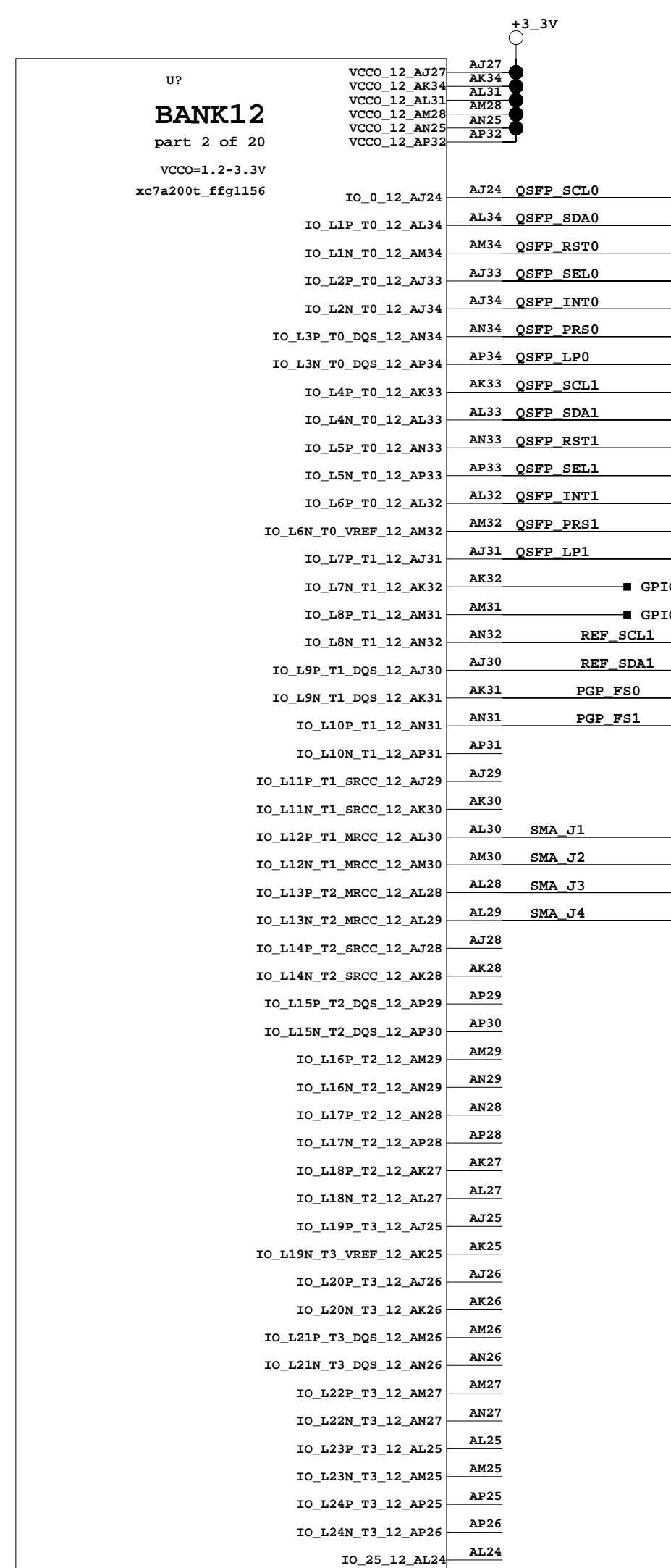
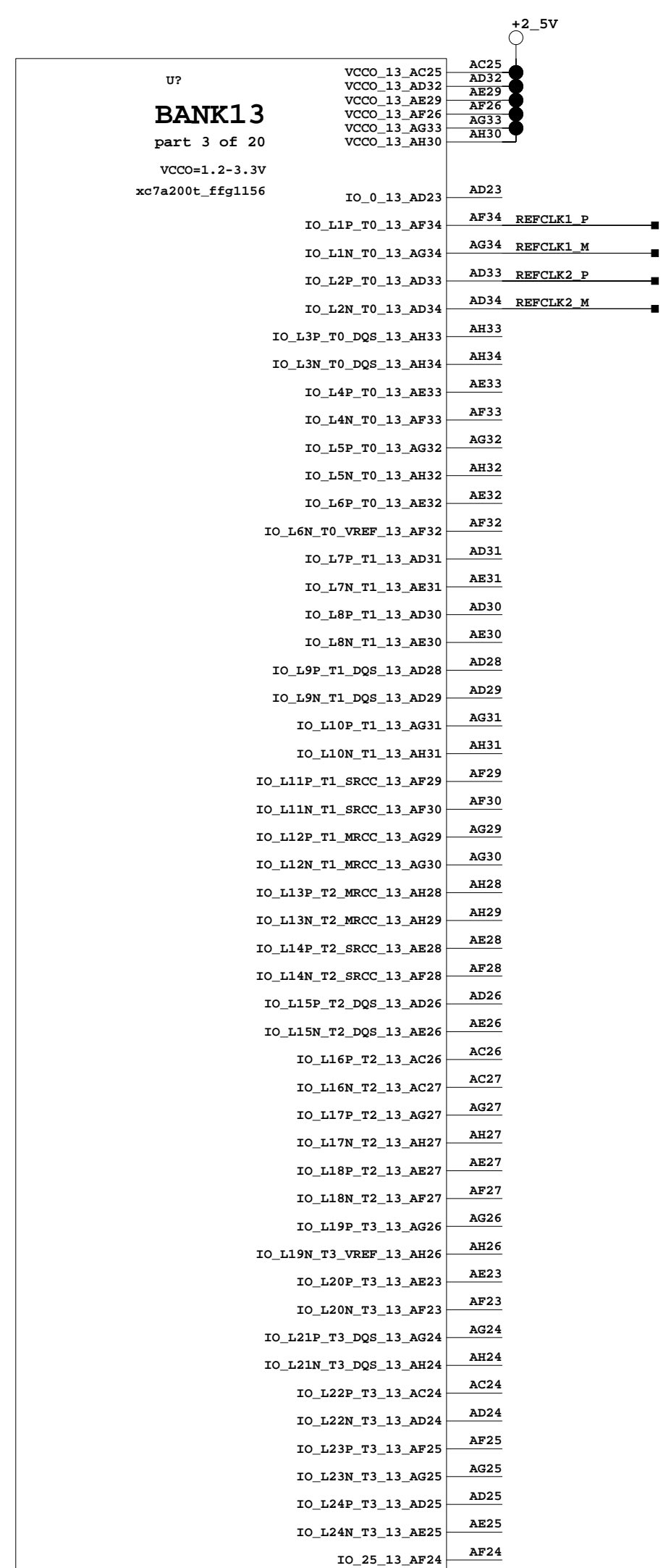

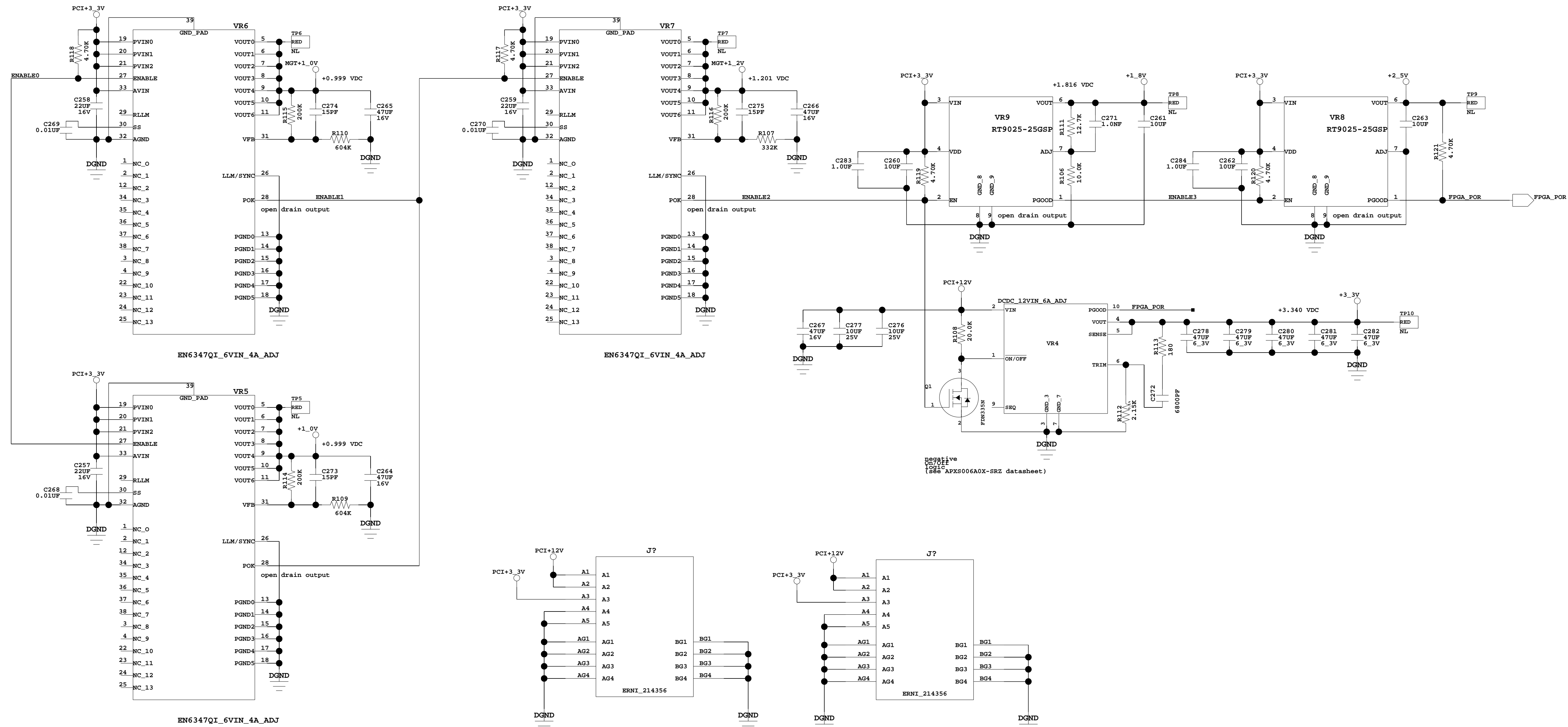

29/01/2014:10:22

SLAC NATIONAL ACCELERATOR LABORATORY U.S. DEPARTMENT OF ENERGY		SHEET 8 OF 8
STANFORD UNIVERSITY STANFORD, CALIFORNIA		PGP CARD Generation 3 Power Regulation Block
PROPRIETARY DATA OF STANFORD UNIVERSITY AND/OR U.S. DEPARTMENT OF ENERGY. RECIPIENT SHALL NOT PUBLISH THE INFORMATION WITHIN UNLESS GRANTED SPECIFIC PERMISSION OF STANFORD UNIVERSITY.		
DATE	APPROVALS	LOCATED AT SHEET 1 SD-260-101-03-C00
DRN Larry Ruckman	2013	
DFR		
CDR		

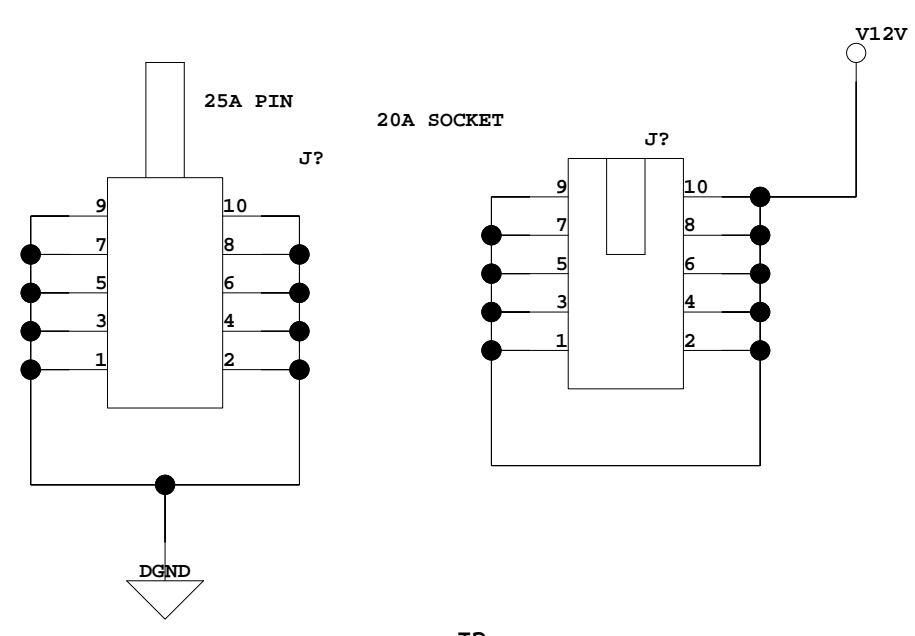

J26\_LVDS\_[31:0]\_P  
 J26\_LVDS\_[31:0]\_M  
 J26\_LVDS\_[39:32]\_P  
 J26\_LVDS\_[39:32]\_M

J27\_LVDS\_[7:0]\_P  
 J27\_LVDS\_[7:0]\_M  
 J27\_LVDS\_[39:8]\_P  
 J27\_LVDS\_[39:8]\_M

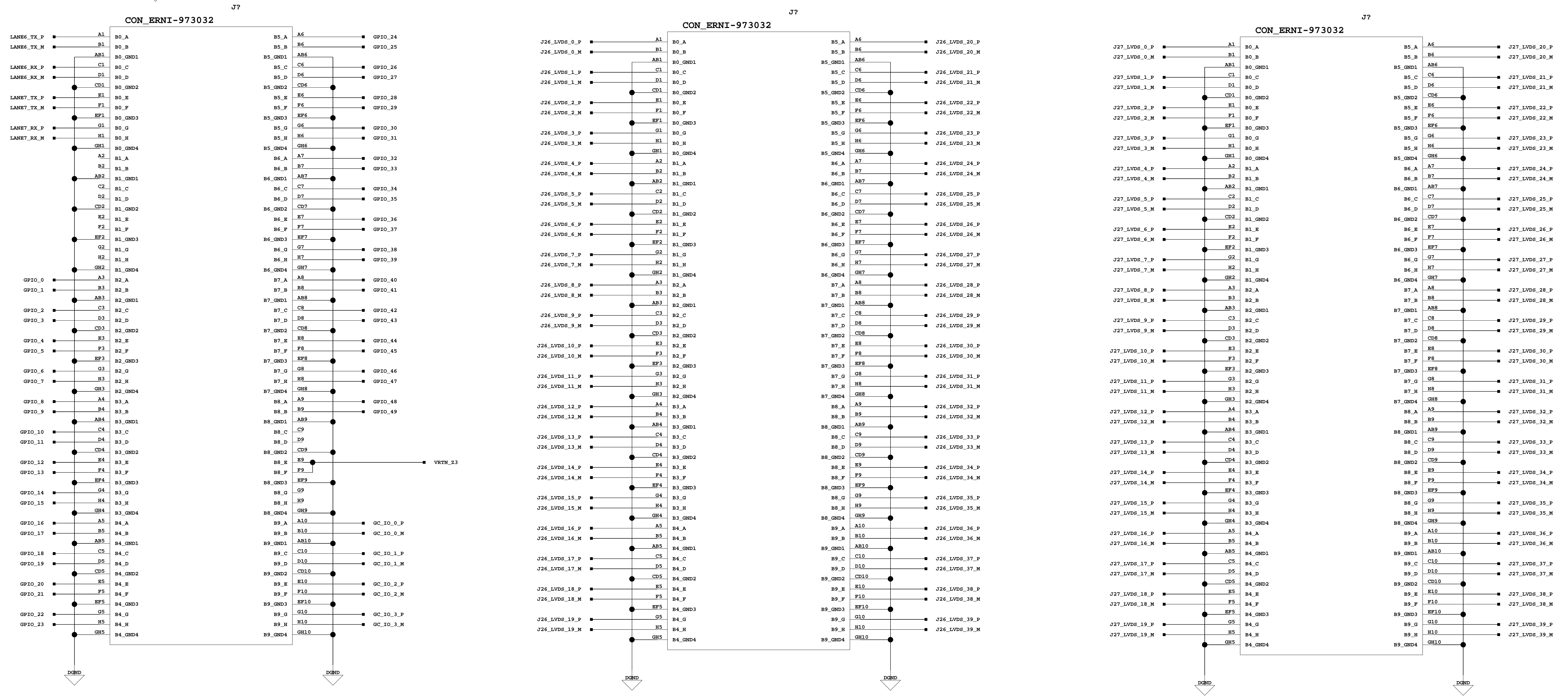

GPIO\_[49:0]

LANE[7:6]\_TX\_P  
 LANE[7:6]\_TX\_M  
 LANE[7:6]\_RX\_P  
 LANE[7:6]\_RX\_M  
 LANE[17:16]\_TX\_P  
 LANE[17:16]\_TX\_M  
 LANE[17:16]\_RX\_P  
 LANE[17:16]\_RX\_M

GC\_IO\_[3:0]\_P  
 GC\_IO\_[3:0]\_M

**SLAC NATIONAL ACCELERATOR LABORATORY**  
**U.S. DEPARTMENT OF ENERGY**

STANFORD UNIVERSITY STANFORD, CALIFORNIA

PROPRIETARY DATA OF STANFORD UNIVERSITY AND/OR U.S. DEPARTMENT OF ENERGY. RECIPIENT SHALL NOT PUBLISH THE INFORMATION WITHIN UNLESS GRANTED SPECIFIC PERMISSION OF STANFORD UNIVERSITY.

DATE	APPROVALS

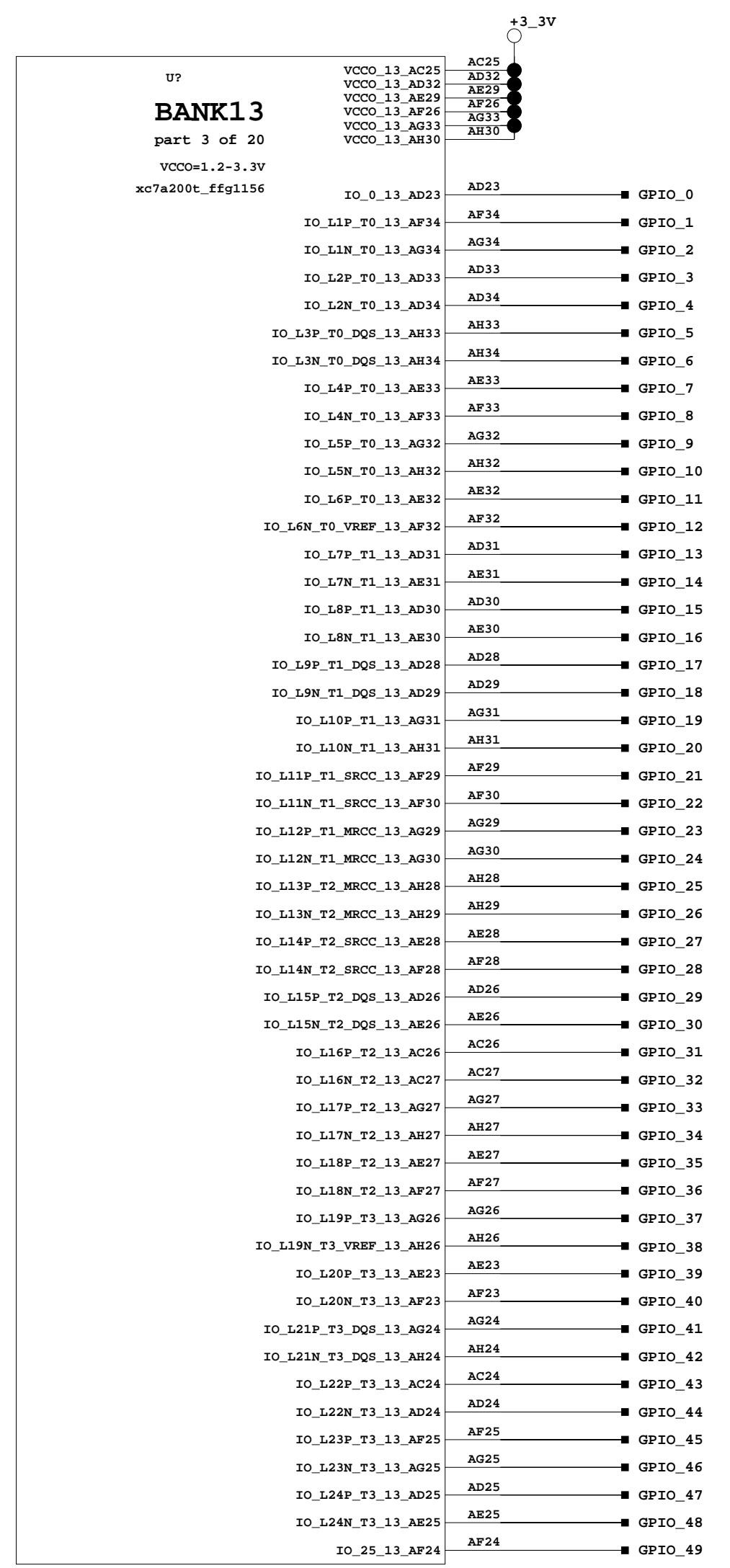

[Empty box]

SLAC NATIONAL ACCELERATOR LABORATORY  
 U.S. DEPARTMENT OF ENERGY  
 STANFORD UNIVERSITY STANFORD, CALIFORNIA

PROPRIETARY DATA OF STANFORD UNIVERSITY AND/OR U.S. DEPARTMENT OF ENERGY. RECIPIENT SHALL NOT PUBLISH THE INFORMATION WITHIN UNLESS GRANTED SPECIFIC PERMISSION OF STANFORD UNIVERSITY.

ENR	DATE	APPROVALS

SHEET OF

**SLAC**

**SD-**

**D**



