

Signals in Particle Detectors (1/2?)

Werner Riegler, CERN

CERN Detector Seminar, 5.9.2008

The principle mechanisms and formulas for signal generation in particle detectors are reviewed.

As examples the signals in parallel plate chambers, wire chambers and silicon detectors are discussed.

Lecture 1: Principles and Signal Theorems

Lecture 2: Signals in Solid State Detectors, Gas Detectors (Wire Chambers, GEMs, MICROMEGAs) and Liquid Calorimeters

Signals in Detectors

During the academic training lectures on particle detectors

<http://indico.cern.ch/conferenceDisplay.py?confId=24765>

a few slides on signal generation principles and signal theorems created quite a lot of questions and discussions.

It seems that there is a need for a discussion of signals in particle detectors.

Although the principles and formulas are well known since a long time, there exists considerable confusion about this topic.

This is probably due to different vocabulary in different detector traditions and also due to the fact that the signal explanations in many (or most !) textbooks on particle detectors are simply wrong.

Creation of the Signal

From a modern detector text book:

... It is important to realize that the signals from wire chambers operating in proportional mode are primarily generated by *induction* due to the moving charges rather than by the *collection* of these charges on the electrodes ...

... When a charged [...] particle traverses the gap, it ionizes the atoms [...]. Because of the presence of an electric field, the electrons and ions created in this process drift to their respective electrodes. The charge collected at these electrodes forms the [...] signal, in contrast to gaseous detectors described above, where the signal corresponds to the current *induced* on the electrodes by the drifting charges (ions). ...

These statements are completely wrong !

All signals in particle detectors are due to *induction* by moving charges. Once the charges have arrived at the electrodes the signals are 'over'.

Creation of the Signal

Charged particles leave a trail of ions (and excited atoms) along their path:
Electron-Ion pairs in gases and liquids, electron hole pairs in solids.

Photons from de-excitation are usually converted to electrons for detection.

The produced charges can be registered → Position measurement → Time measurement → Tracking Detectors

Cloud Chamber: Charges create drops → photography.

Bubble Chamber: Charges create bubbles → photography.

Emulsion: Charges 'blacked' the film.

Spark Chamber: Charges produce a conductive channel that create a discharge → photography

Gas and Solid State Detectors: Moving Charges (electric fields) induce electronic signals on metallic electrons that can be read by dedicated electronics.

→In solid state detectors the charge created by the incoming particle is sufficient (not exactly correct, in Avalanche Photo Diodes one produces avalanches in a solid state detector)

→In gas detectors (e.g. wire chamber) the charges are internally multiplied in order to provide a measurable signal.

Cloud Chamber, C.T.R. Wilson 1910

Charges act as condensation nuclei in supersaturated water vapor

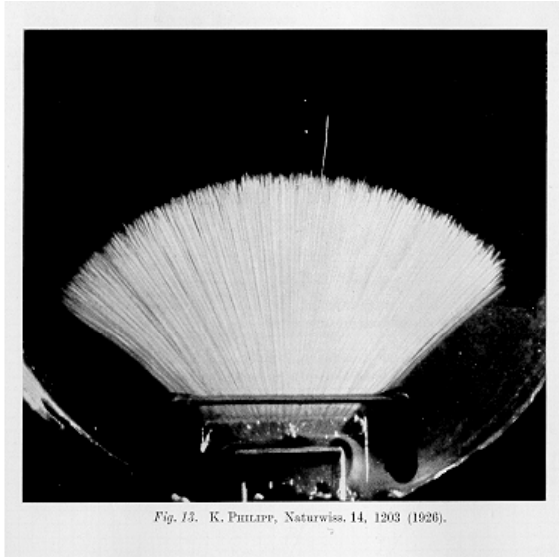

Alphas, Philipp 1926

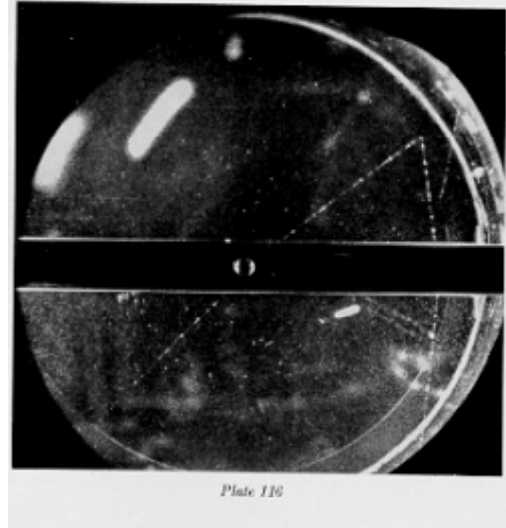
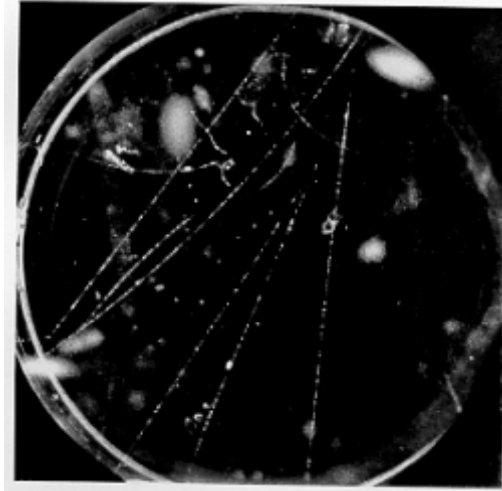

V- particles, Rochester and Wilson, 1940ies

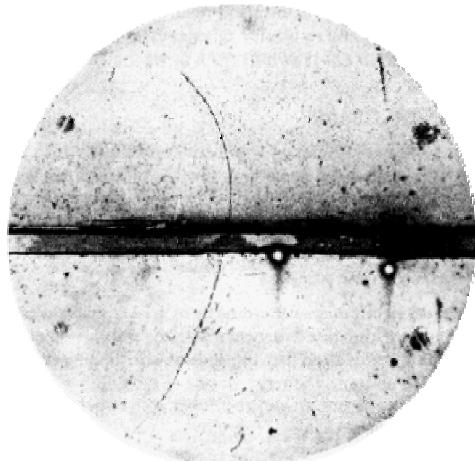

Positron discovery, Carl Andersen 1933

Nuclear Emulsion, M. Blau 1930ies

Charges initiate a chemical reaction that blackens the emulsion (film)

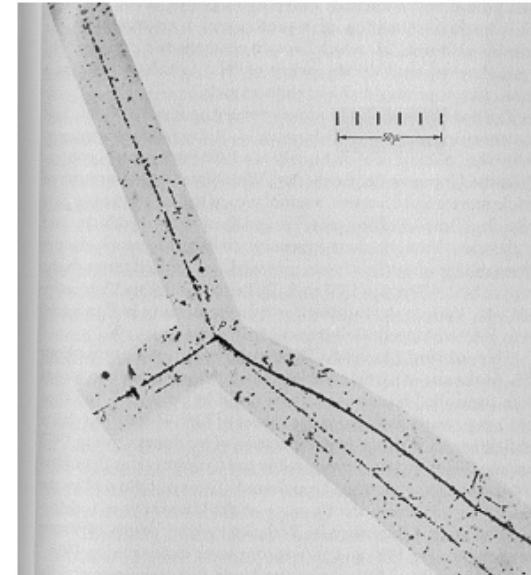
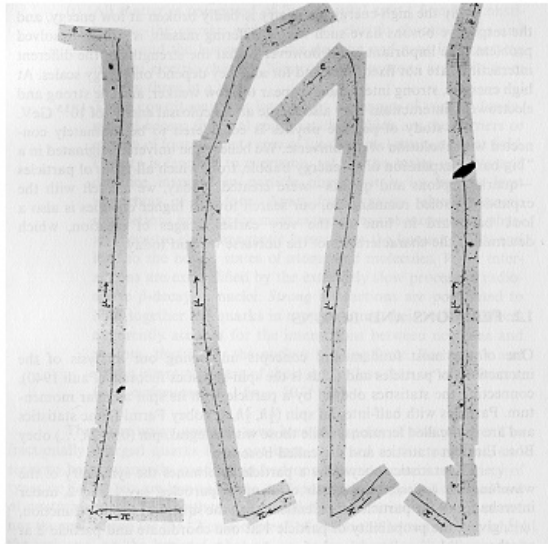

C. Powell, Discovery of muon and pion, 1947

Kaon Decay into 3 pions, 1949

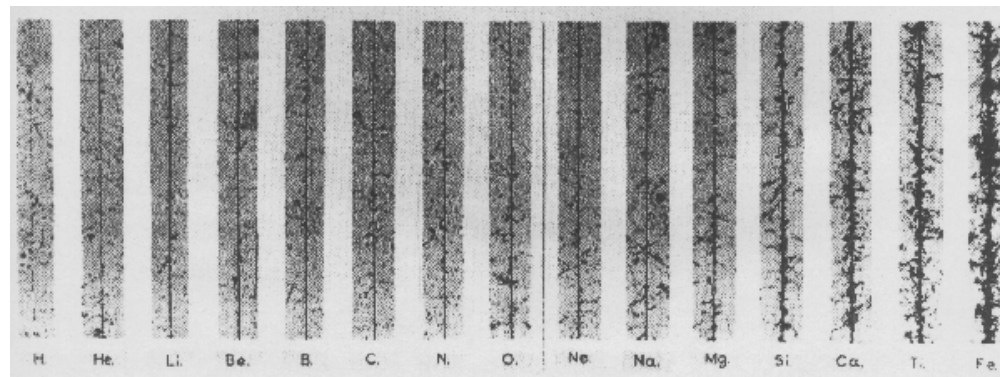

Cosmic Ray Composition

Bubble Chamber, D. Glaser 1952

Charges create bubbles in superheated liquid, e.g. propane or Hydrogen (Alvarez)

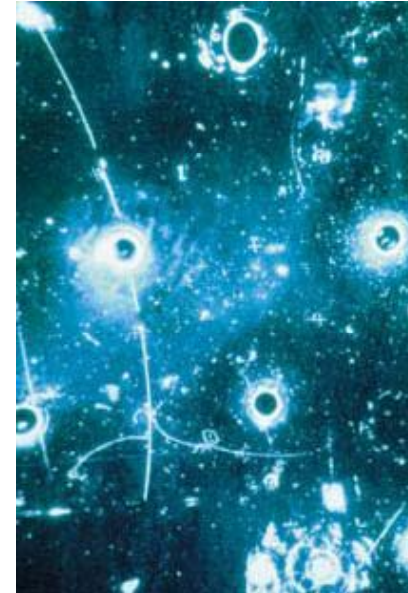
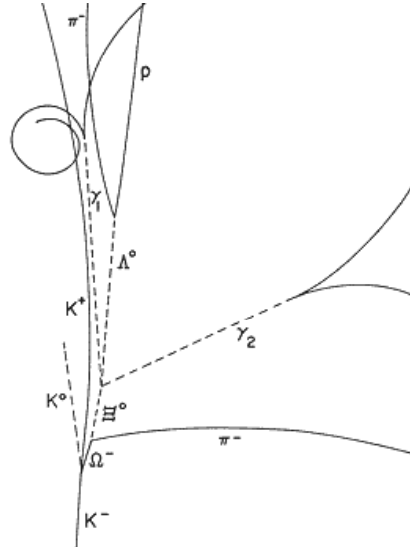
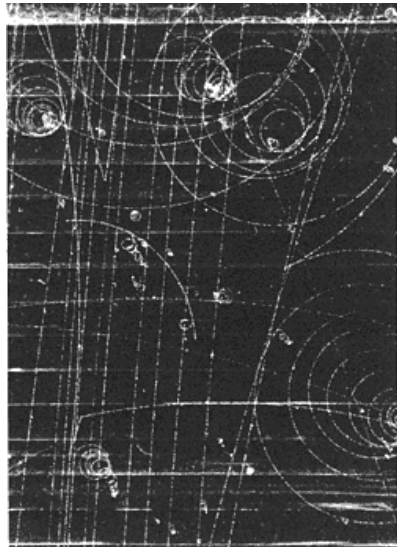

Discovery of the ϕ^- in 1964

Neutral Currents 1973

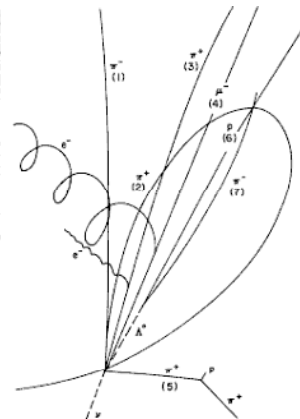
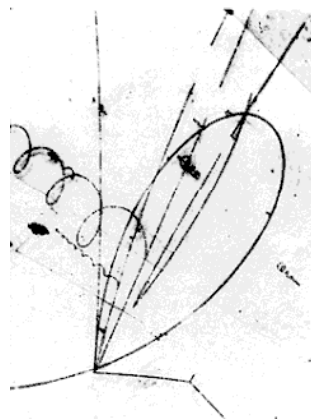

Charmed Baryon, 1975

Spark Chamber, 1960ies

Charges create 'conductive channel' which initiates a spark in case HV is applied.

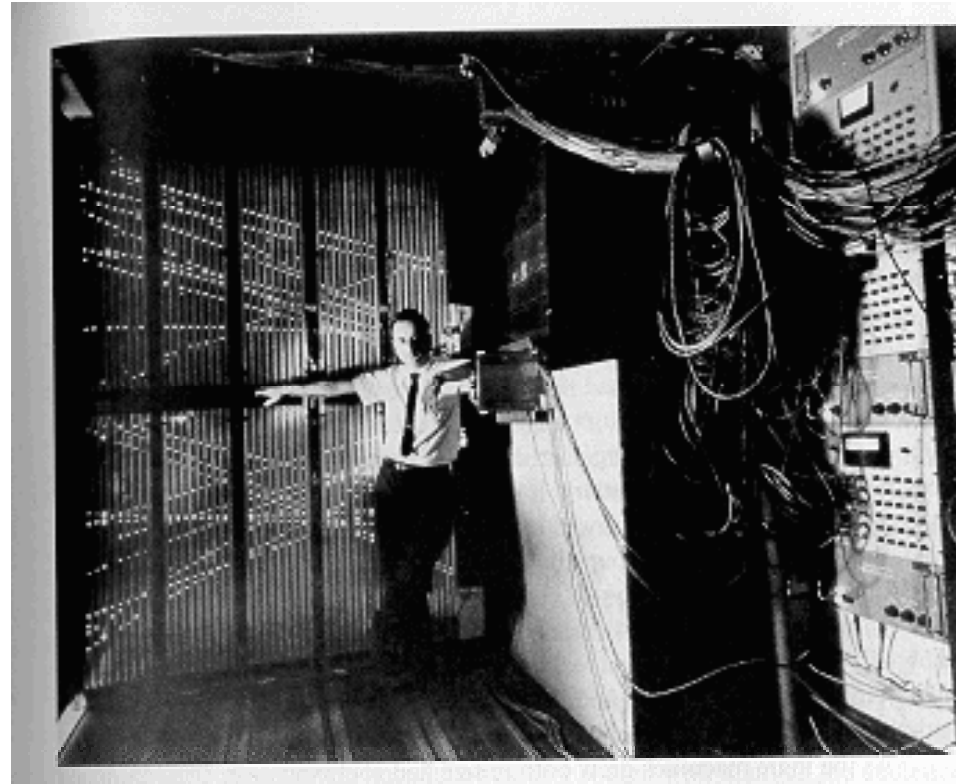
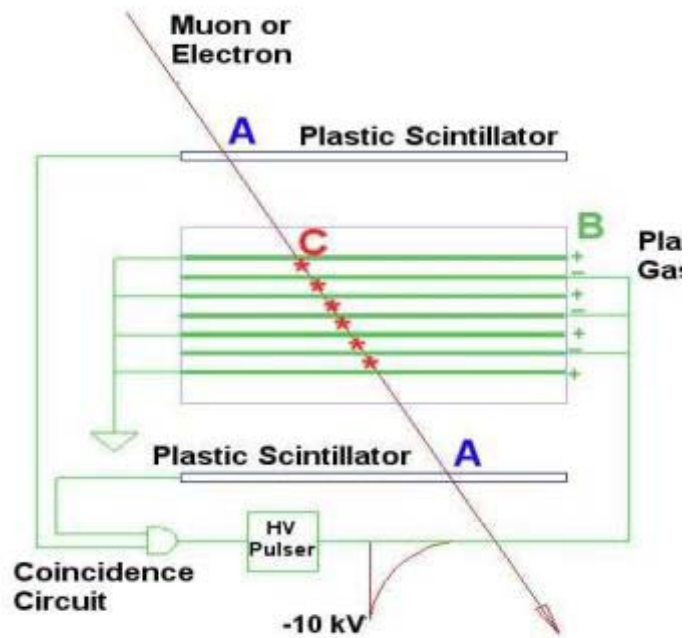

Discovery of the Muon Neutrino 1960ies

Tip Counter, Geiger 1914

Charges create a discharge of a needle which is at HV with respect to a cylinder.

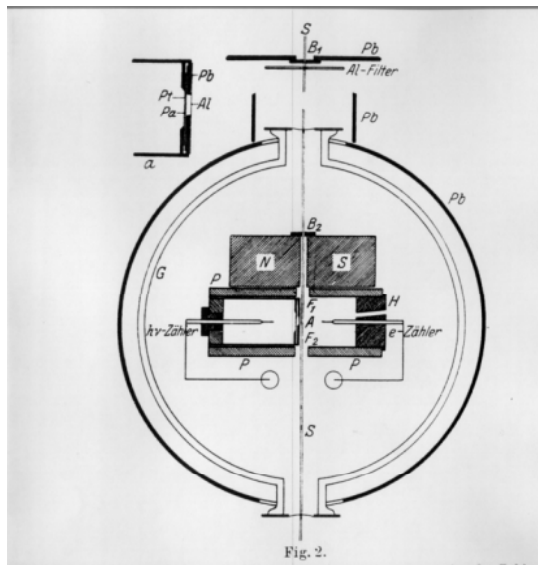

The needle is connected to an electrostatic that can detect the produced charge.

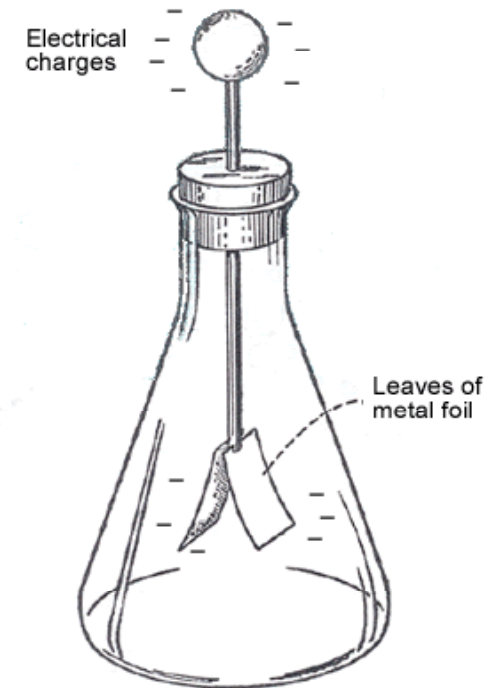

Electric Registration of Geiger Müller Tube Signals

Charges create a discharge in a cylinder with a thin wire set to HV. The charge is measured with a electronics circuit consisting of tubes → electronic signal.

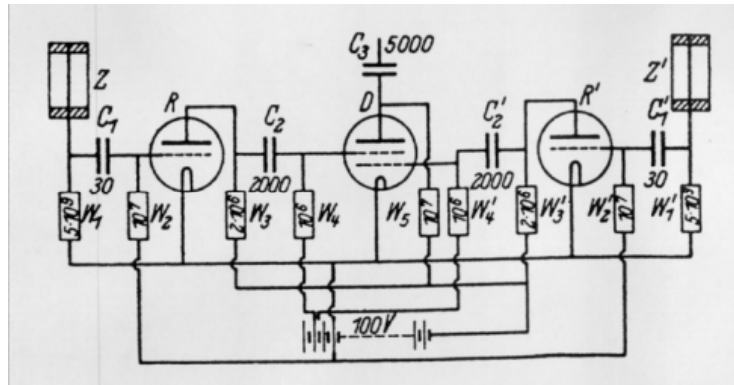

W. Bothe, 1928

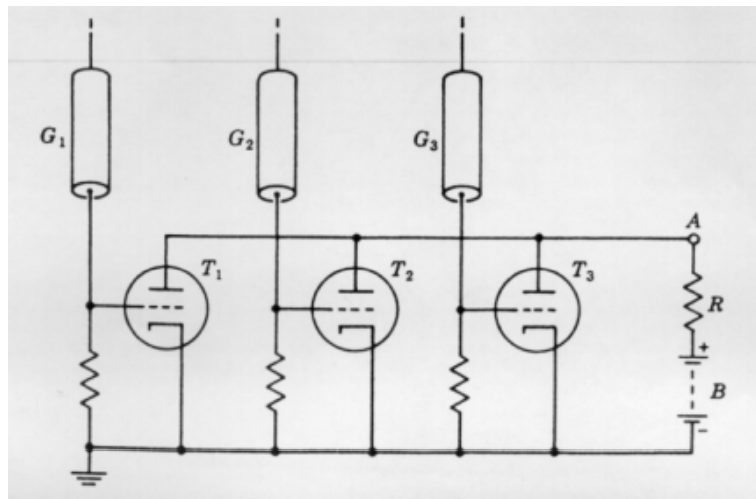

B. Rossi, 1932

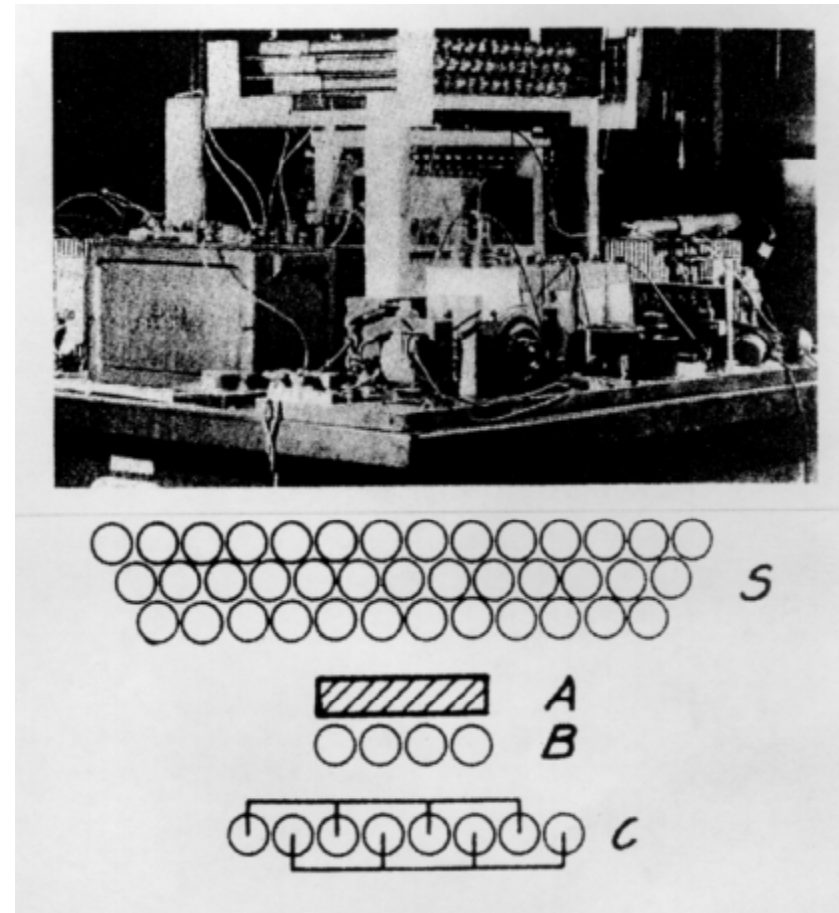

Cosmic Ray Telescope 1930ies

Ionization Chambers, Wire Chambers, Solid State Detectors

!The movement of charges in electric fields induces signal on readout electrodes (No discharge, there is no charge flowing from cathode to Anode) !

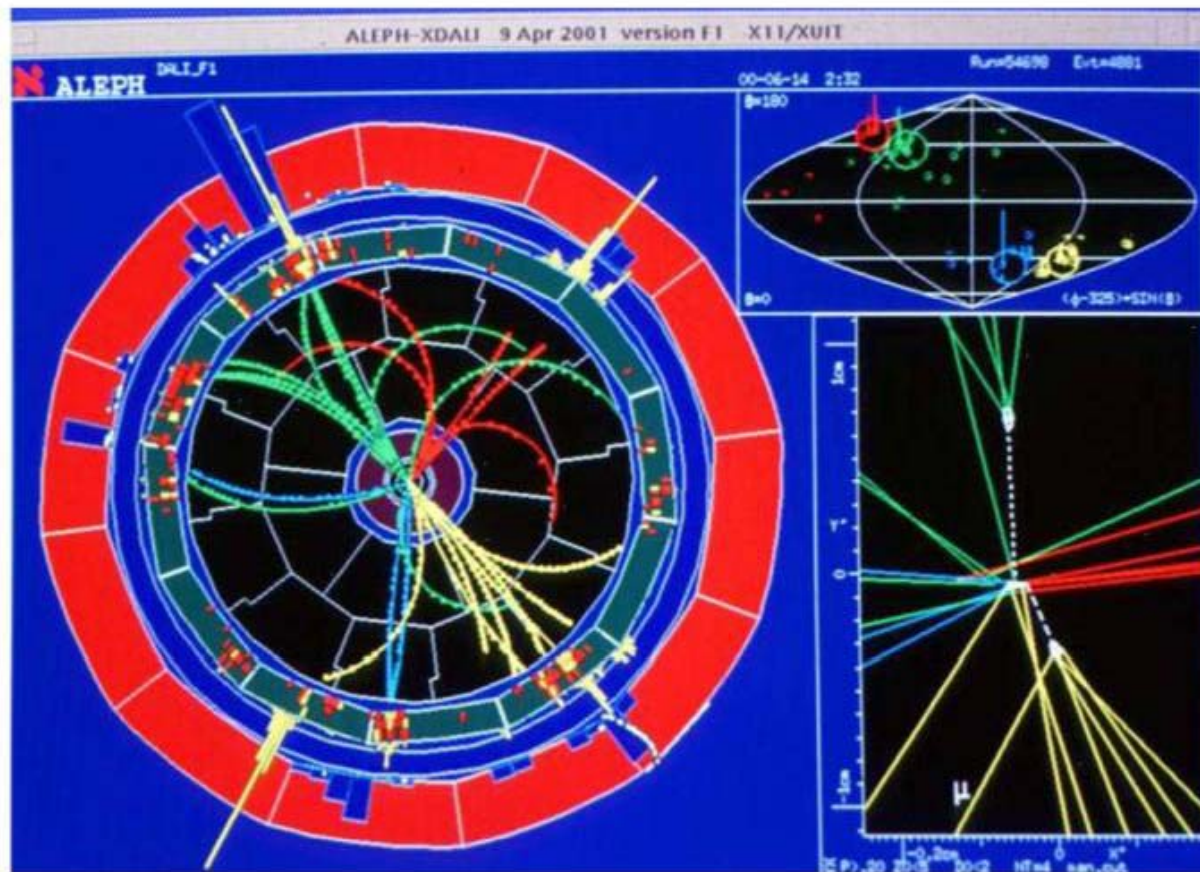

The Principle of Signal Induction on Metal Electrodes by Moving Charges

Induced Charges

A point charge q at a distance z_0 above a grounded metal plate 'induces' a surface charge.

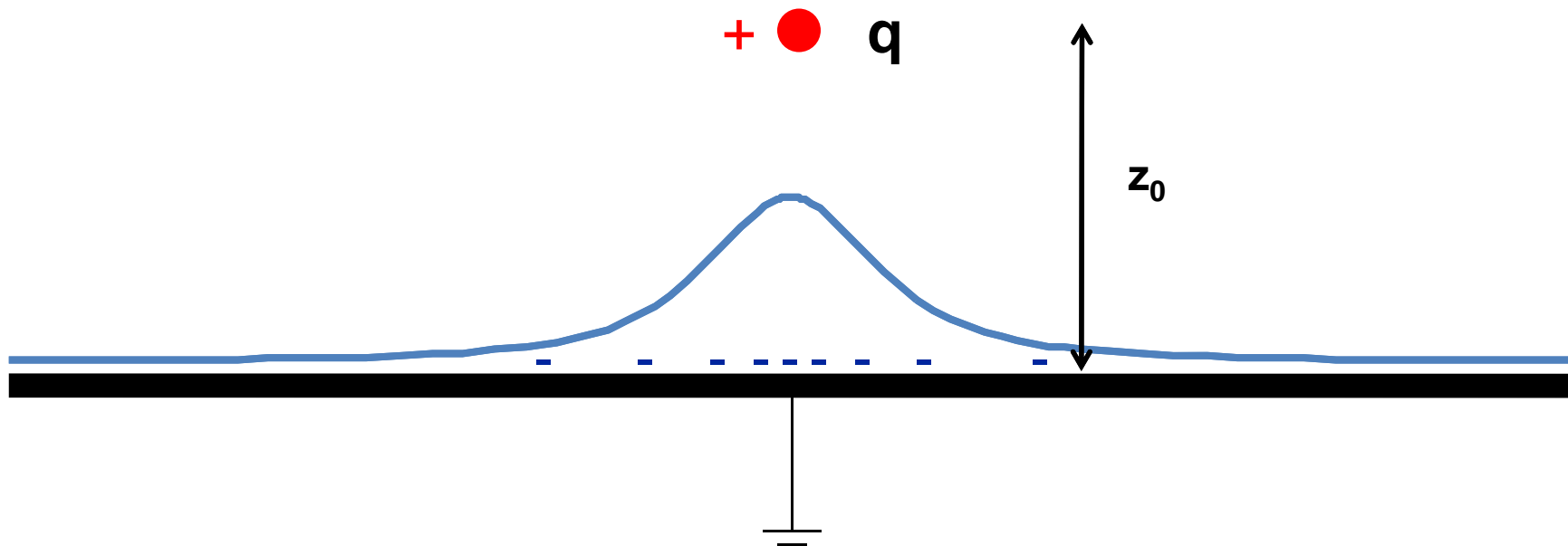

Electrostatics, Things we Know

Poisson Equation:

$$\Delta\varphi = -\frac{\rho}{\epsilon_0} \quad \vec{E} = -\vec{\nabla}\varphi$$

Gauss Law:

$$\oint \vec{E} d\vec{A} = \frac{1}{\epsilon_0} \int \rho dV$$

→ **Metal Surface: Electric Field is perpendicular to the surface. Charges are only on the surface. Surface Charge Density σ and electric E field on the surface are related by**

$$E A = \frac{1}{\epsilon_0} \sigma A \quad \rightarrow \quad \sigma = \epsilon_0 E$$

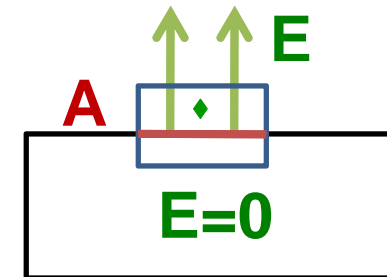
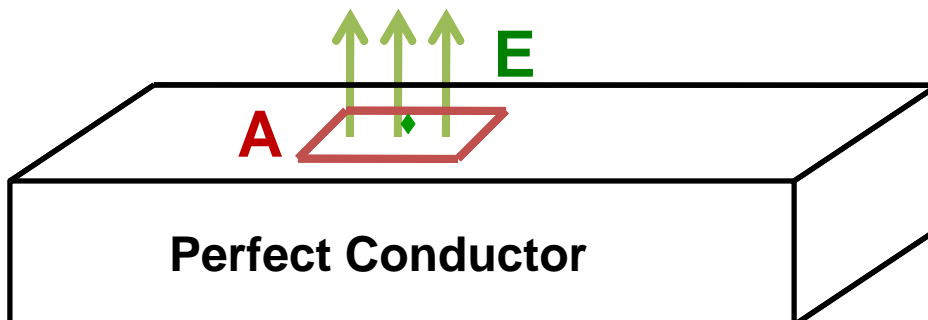

Induced Charges

In order to find the charge induced on an electrode we therefore have to

- a) Solve the Poisson equation with boundary condition that $\mathcal{E}_n=0$ on the conductor surface.
- b) Calculate the electric field E on the surface of the conductor
- c) Integrate e_0E over the electrode surface.

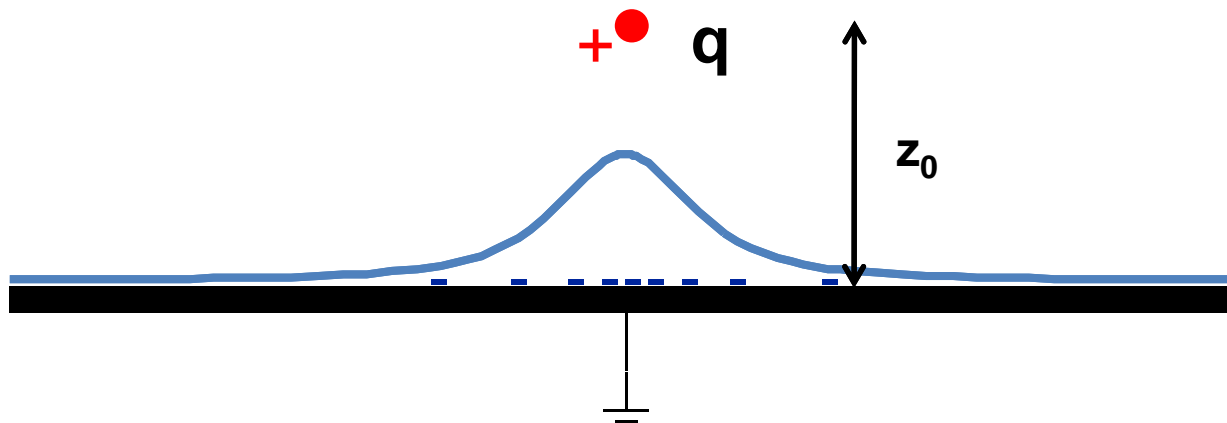

Induced Charges

The solution for the field of a point charge in front of a metal plate is equal to the solution of the charge together with a (negative) mirror charge at $z=-z_0$.

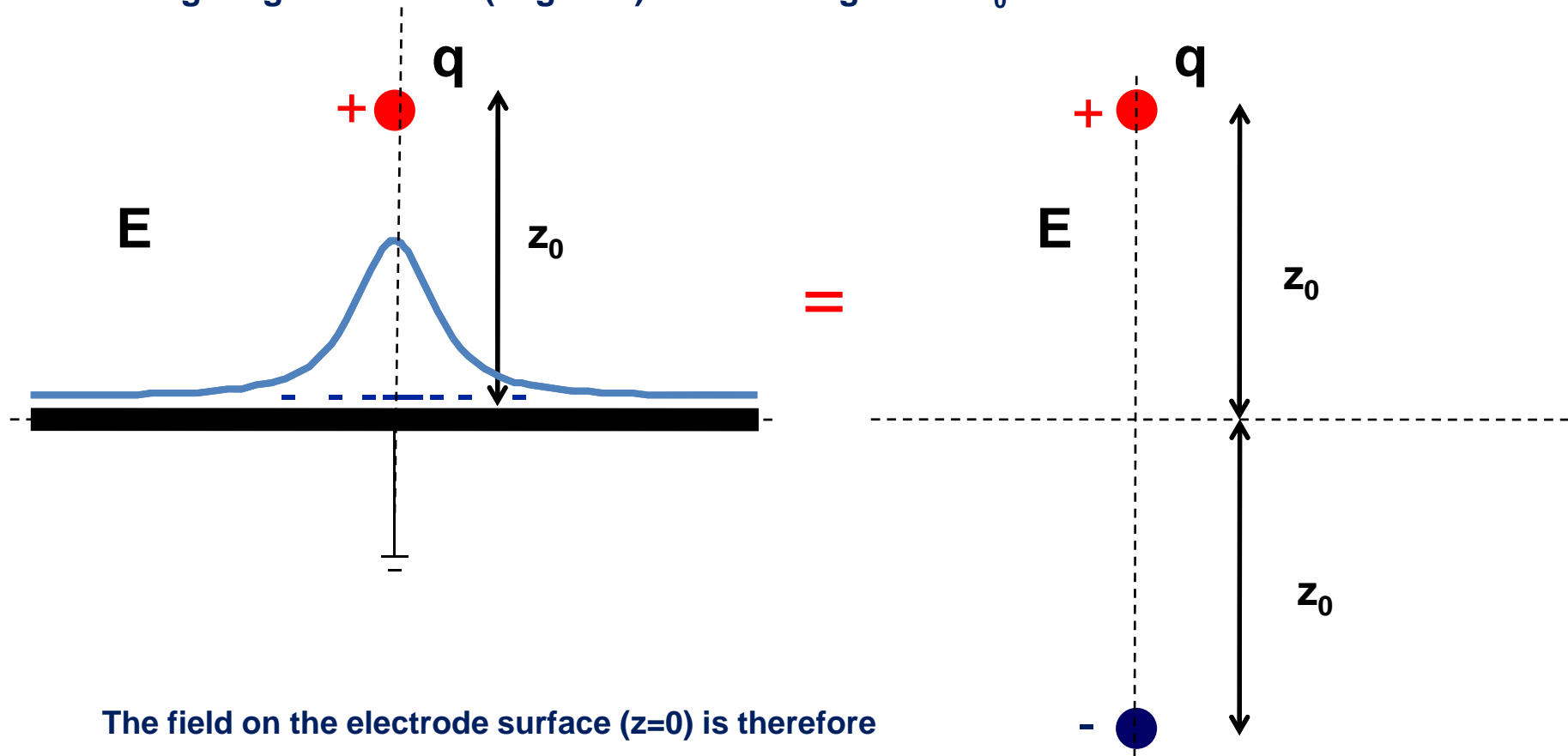

The field on the electrode surface ($z=0$) is therefore

$$E_z(x, y) = -\frac{qz_0}{2\pi\epsilon_0(x^2 + y^2 + z_0^2)^{\frac{3}{2}}}$$

$$E_x = E_y = 0$$

Induced Charges

We therefore find a surface charge density of

$$\sigma(x, y) = \varepsilon_0 E_z(x, y) = -\frac{qz_0}{2\pi(x^2 + y^2 + z_0^2)^{\frac{3}{2}}}$$

And therefore a total induced charge of

$$Q = \int_{-\infty}^{\infty} \int_{-\infty}^{\infty} \sigma(x, y) dx dy = -q$$

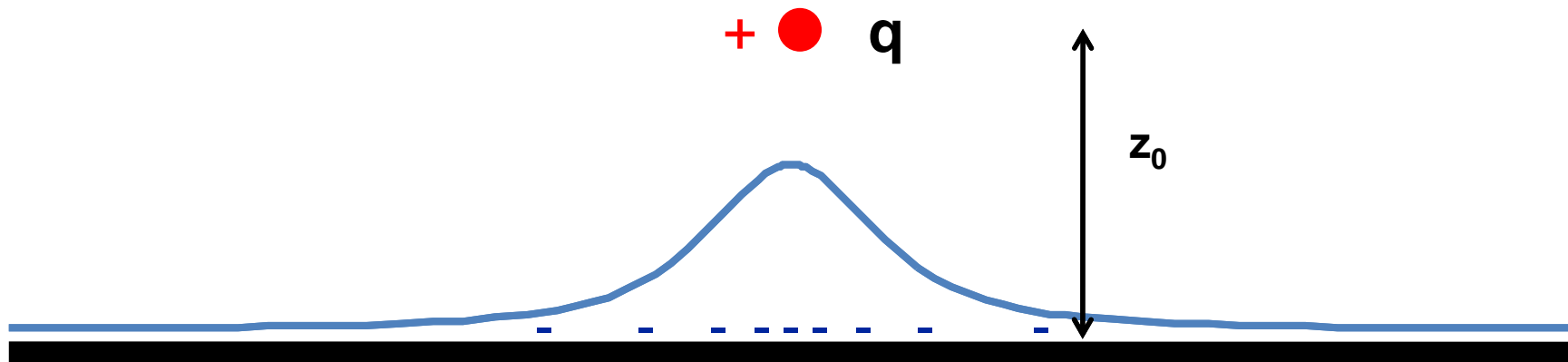

Induced Charges

The total charge induced by a point charge q on an infinitely large grounded metal plate is equal to $-q$, independent of the distance of the charge from the plate.

The surface charge distribution is however depending on the distance z_0 of the charge q .

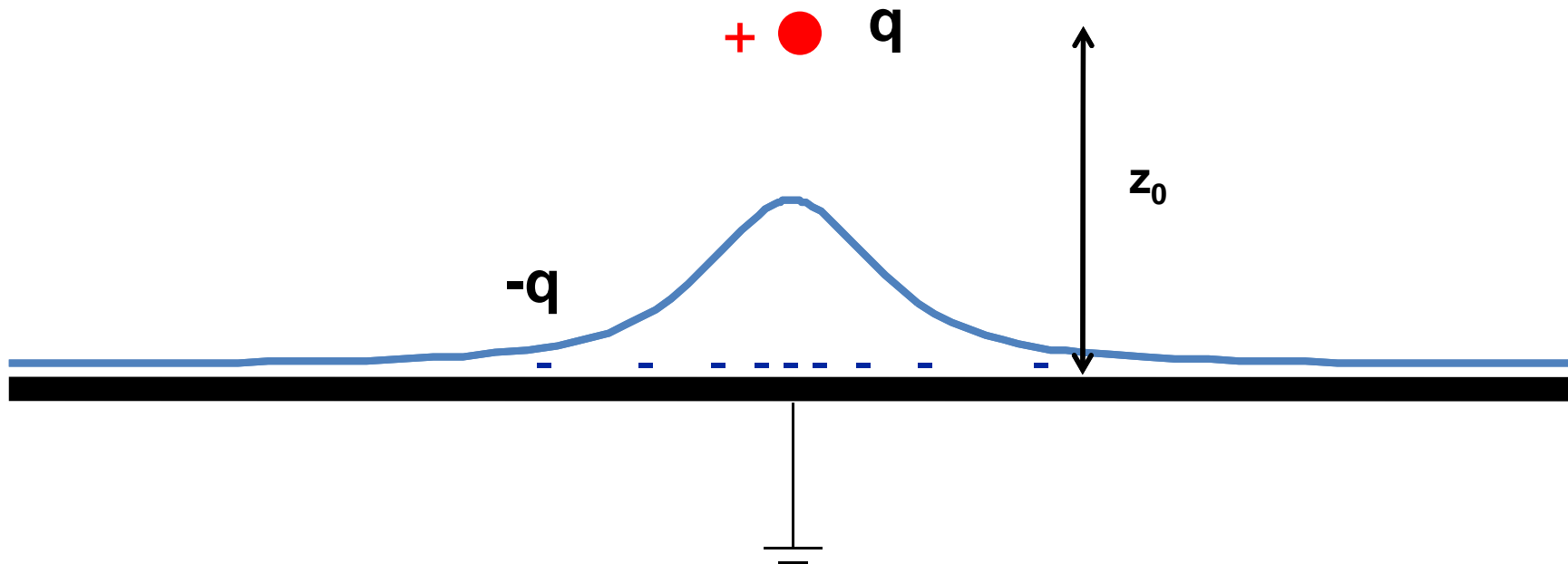

Induced Charges

Moving the point charge closer to the metal plate, the surface charge distribution becomes more peaked, the total induced charge is however always equal to $-q$.

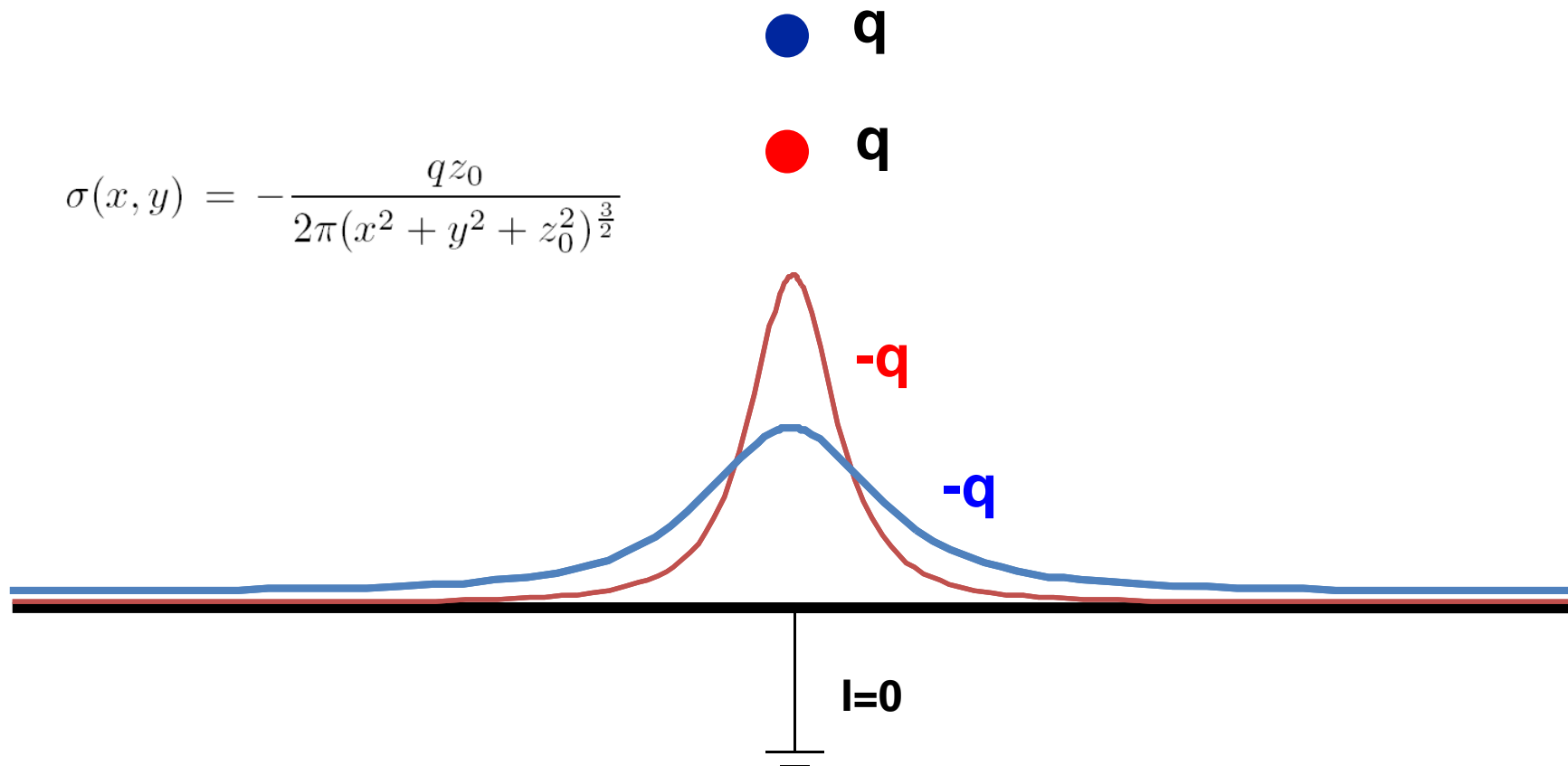

Signal Induction by Moving Charges

If we segment the grounded metal plate and if we ground the individual strips, the surface charge density doesn't change with respect to the continuous metal plate.

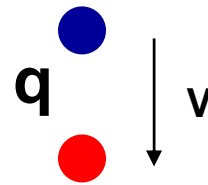

The charge induced on the individual strips is now depending on the position z_0 of the charge.

If the charge is moving there are currents flowing between the strips and ground.

→ The movement of the charge induces a current.

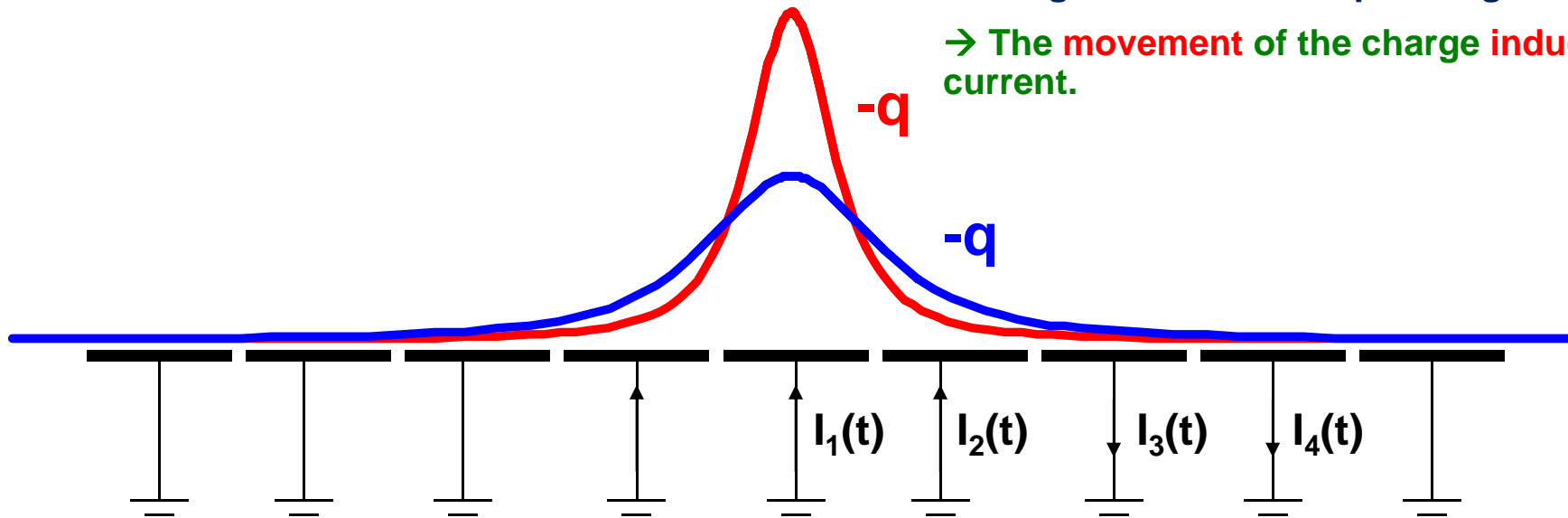

$$Q_1(z_0) = \int_{-\infty}^{\infty} \int_{-w/2}^{w/2} \sigma(x, y) dx dy = -\frac{2q}{\pi} \arctan\left(\frac{w}{2z_0}\right) \quad z_0(t) = z_0 - vt$$

$$I_1^{ind}(t) = -\frac{d}{dt} Q_1[z_0(t)] = -\frac{\partial Q_1[z_0(t)]}{\partial z_0} \frac{dz_0(t)}{dt} = \frac{4qw}{\pi[4z_0(t)^2 + w^2]} v$$

Formulation of the Problem

In a real particle detector, the electrodes (wires, cathode strips, silicon strips, plate electrodes ...) are not grounded but they are connected to readout electronics and interconnected by other discrete elements.

We want to answer the question:

What are the voltages induced on metal electrodes by a charge q moving along a trajectory $x(t)$, in case these metal electrodes are connected by arbitrary linear impedance components ?

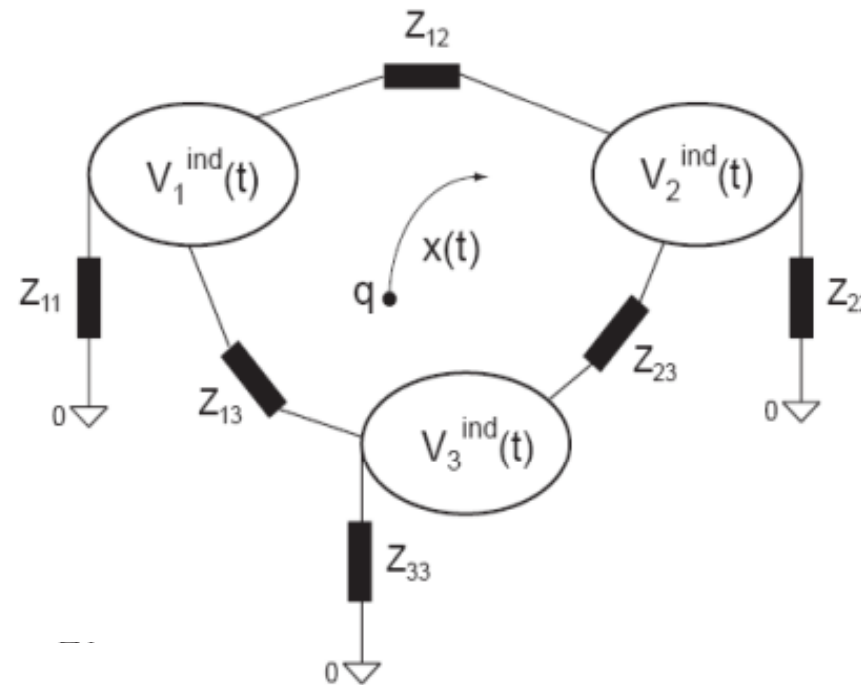

Formulation of the Problem

We will divide the problem into two parts:

We first calculate the currents induced on grounded electrodes.

A theorem, that we will proof later, states that we then have to place these currents as ideal current sources on a circuit containing the discrete components and the mutual electrode capacitances

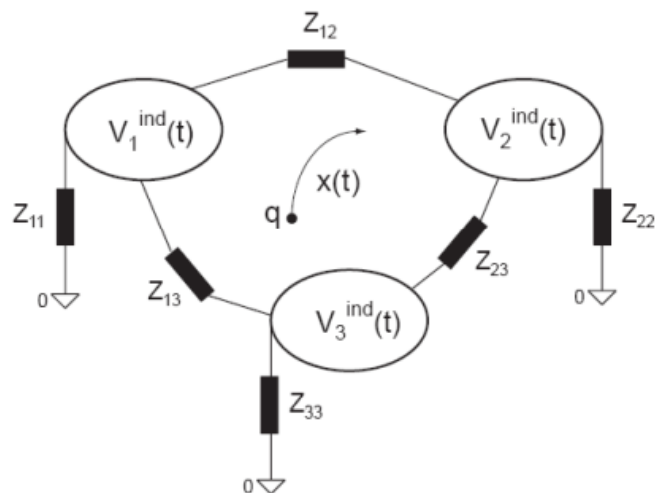

=

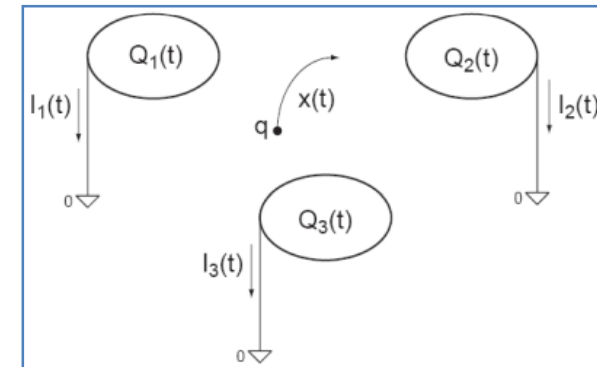

+

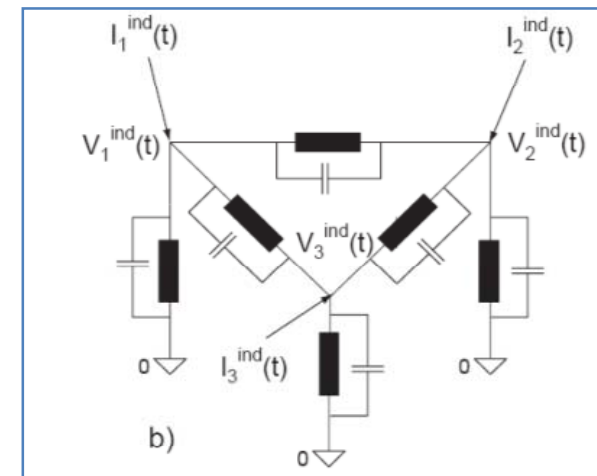

The second step is typically performed by using an analog circuit simulation program. We will first focus on the induced currents.

Currents on Grounded Electrodes

We can imagine this case by reading the signal with an ideal current amplifier of zero input impedance

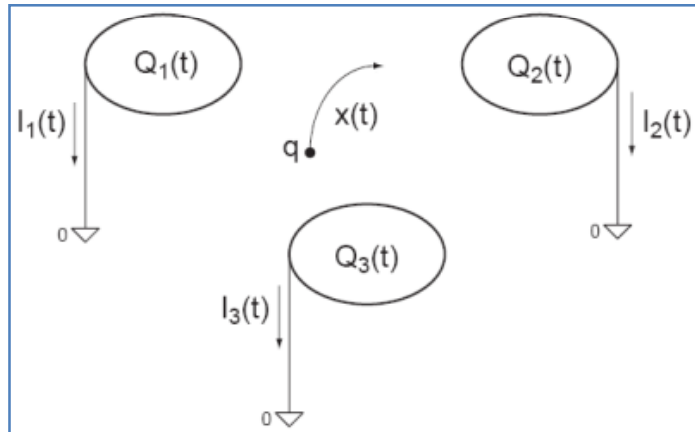

=

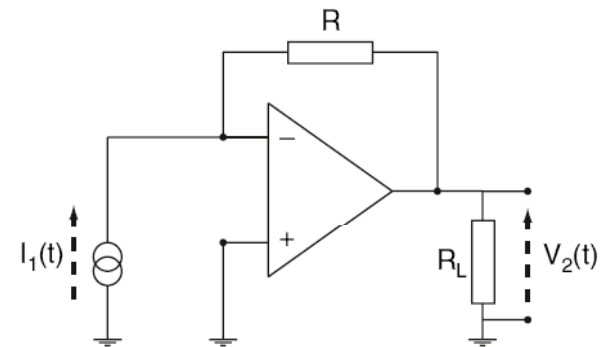
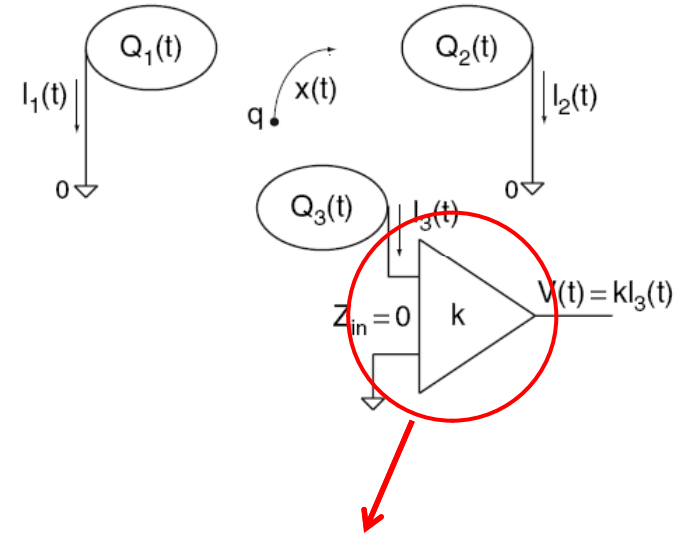

$$V_2(t) = -R I_1(t)$$

Parallel Plate Chamber

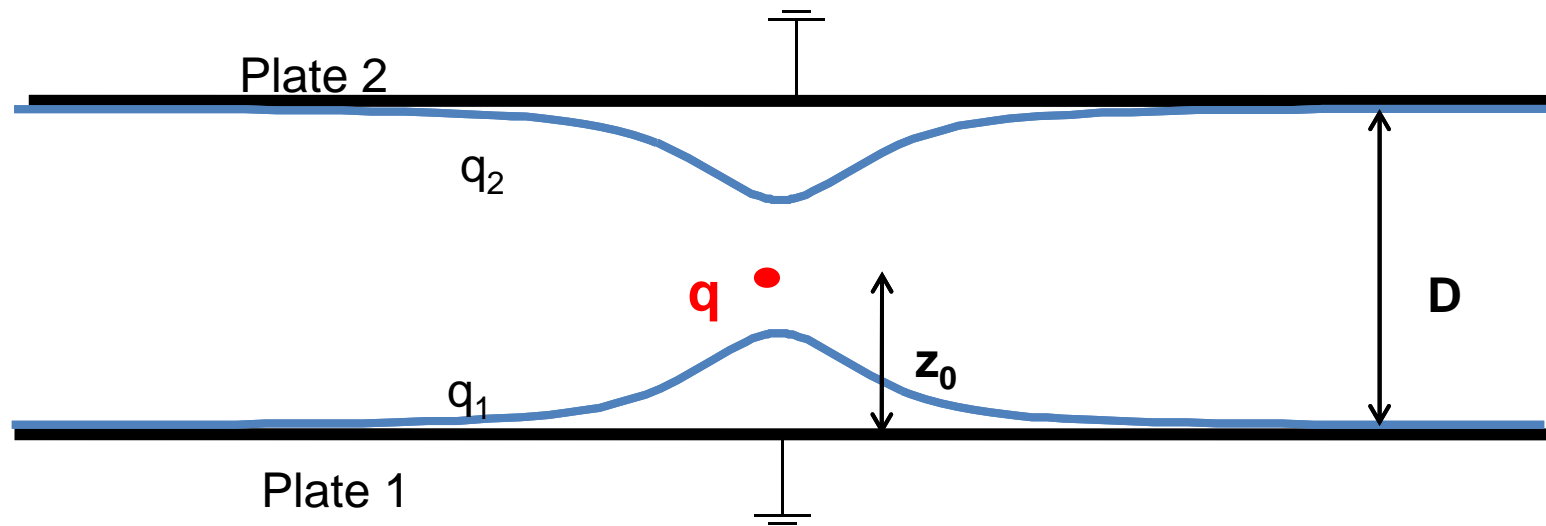

$$\phi(r, z) = \frac{q}{\varepsilon_0 \pi D} \sum_{n=1}^{\infty} \sin\left(\frac{n\pi}{D} z\right) \sin\left(\frac{n\pi}{D} z_0\right) K_0\left(\frac{n\pi}{D} r\right) \quad [5]$$

$$E(r, z) = \frac{q}{\varepsilon_0 \pi D} \sum_{n=1}^{\infty} \frac{n\pi}{D} \cos\left(\frac{n\pi}{D} z\right) \sin\left(\frac{n\pi}{D} z_0\right) K_0\left(\frac{n\pi}{D} r\right)$$

$$\sigma_1(r) = \varepsilon_0 E(r, z=0) = \frac{q}{\pi D} \sum_{n=1}^{\infty} \frac{n\pi}{D} \sin\left(\frac{n\pi}{D} z_0\right) K_0\left(\frac{n\pi}{D} r\right)$$

[5] C. Y. Fong, C. Kittel, Induced Charge on Capacitor Plates, Am. J. Phys. 35(1967)1091.

Parallel Plate Chamber

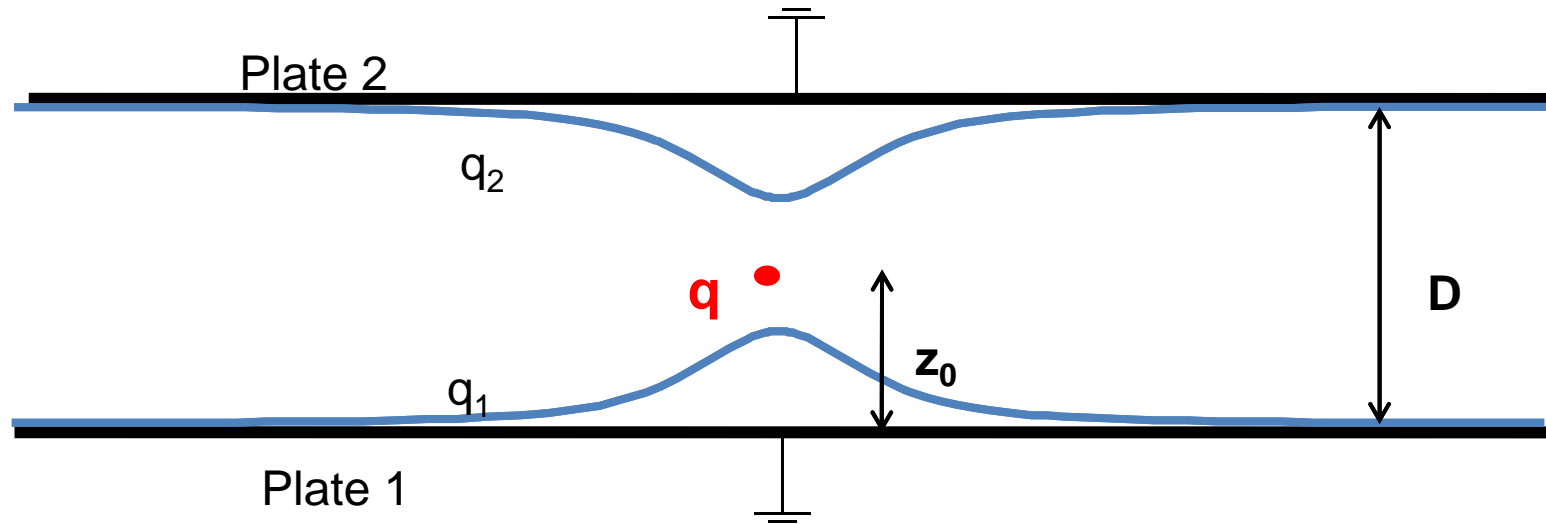

$$q_1 = \int_0^\infty 2r\pi\sigma(r)dr = \frac{q}{\pi D} \sum_{n=1}^{\infty} \frac{n\pi}{D} \sin\left(\frac{n\pi}{D} z_0\right) \int_0^\infty 2r\pi K_0\left(\frac{n\pi}{D} r\right) dr = \frac{2q}{\pi} \sum_{n=1}^{\infty} \frac{1}{n} \sin\left(\frac{n\pi}{D} z_0\right) =$$

$$= -q \left(1 - \frac{z_0}{D}\right)$$

$$q_2 = \dots = -q \frac{z_0}{D}$$

$$q_1 + q_2 = -q$$

Parallel Plate Chamber

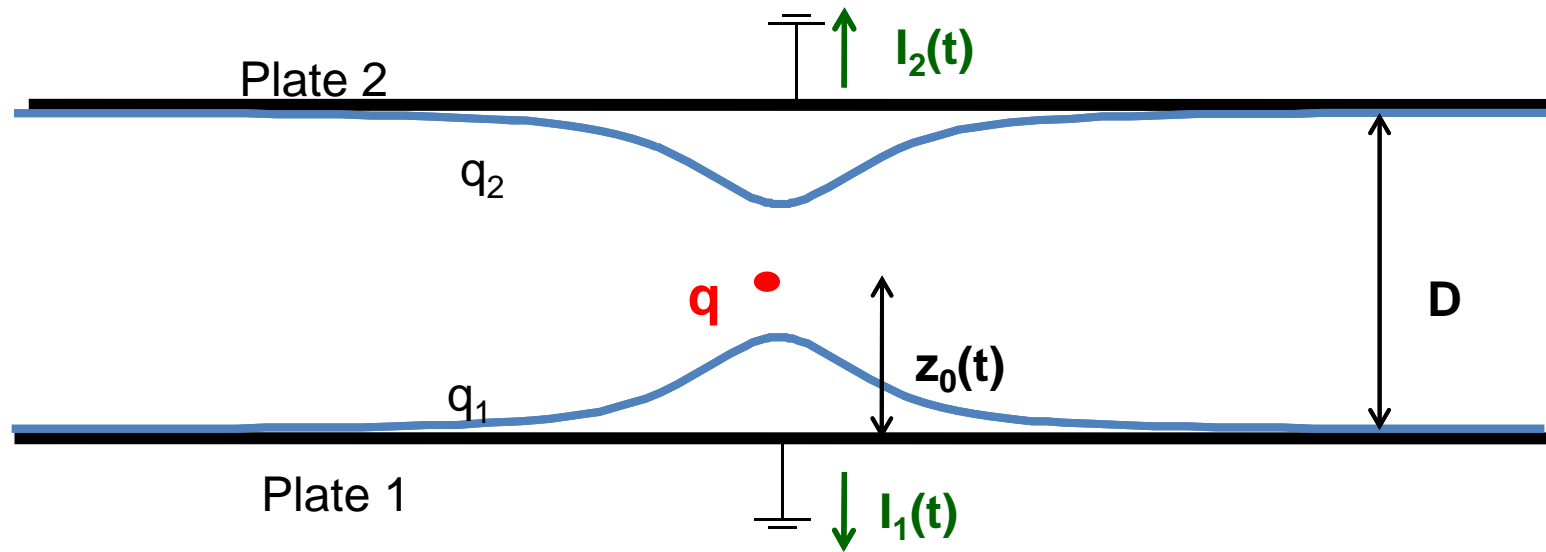

$$q_1 = -q \left(1 - \frac{z_0}{D}\right)$$

$$q_2 = -q \frac{z_0}{D}$$

$$z_0(t) = vt$$

$$q_1(t) = -q \left(1 - \frac{vt}{D}\right)$$

$$q_2(t) = -q \frac{vt}{D}$$

$$q_1(t) + q_2(t) = q$$

$$I_1(t) = -\frac{dq_1(t)}{dt} = -\frac{qv}{D}$$

$$I_2(t) = -\frac{dq_2(t)}{dt} = +\frac{qv}{D}$$

$$I_1(t) + I_2(t) = 0$$

Parallel Plate Chamber

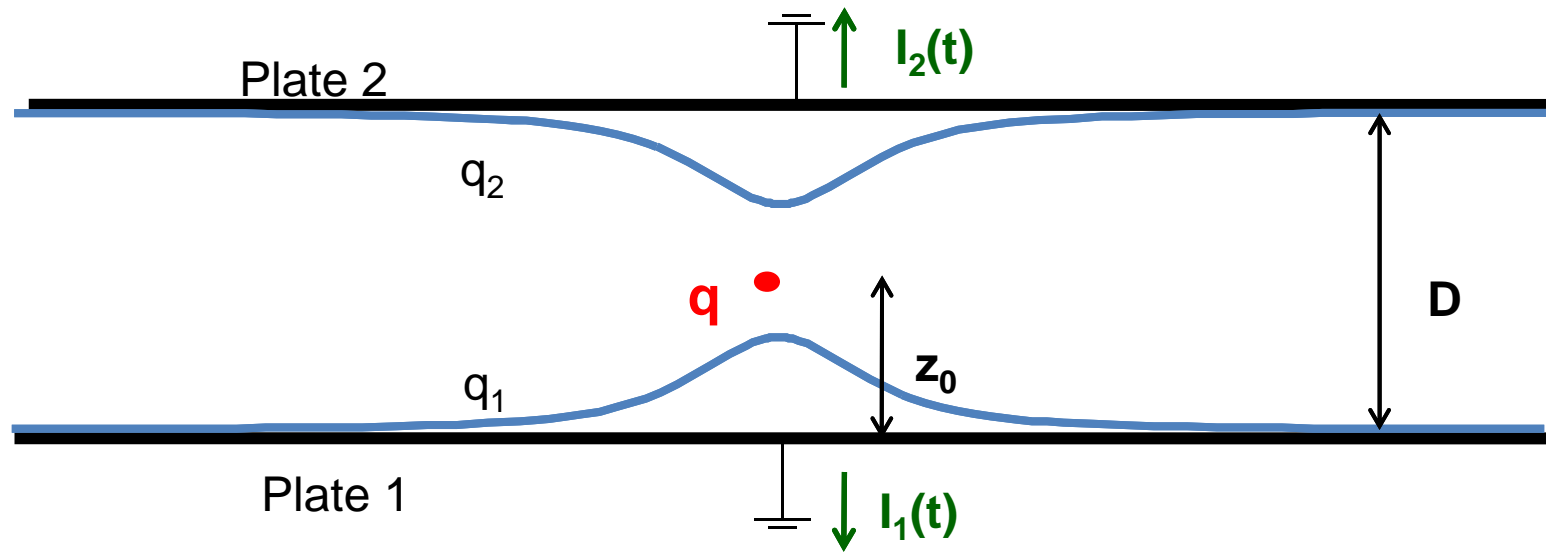

$$q_1(t) = -q \left(1 - \frac{vt}{D} \right) \quad q_2(t) = -q \frac{vt}{D} \quad I_1(t) = -\frac{dq_1(t)}{dt} = -\frac{qv}{D} \quad I_2(t) = -\frac{dq_2(t)}{dt} = +\frac{qv}{D}$$

The sum of all induced charges is equal to the moving charge at any time.

The sum of the induced currents is zero at any time.

The field calculation is complicated, the formula for the induced signal is however very simple – there might be an easier way to calculate the signals ?

→ Ramo-Schottky theorem !

Signal Polarity Definition

$$I(t) = -\frac{dQ(t)}{dt}$$

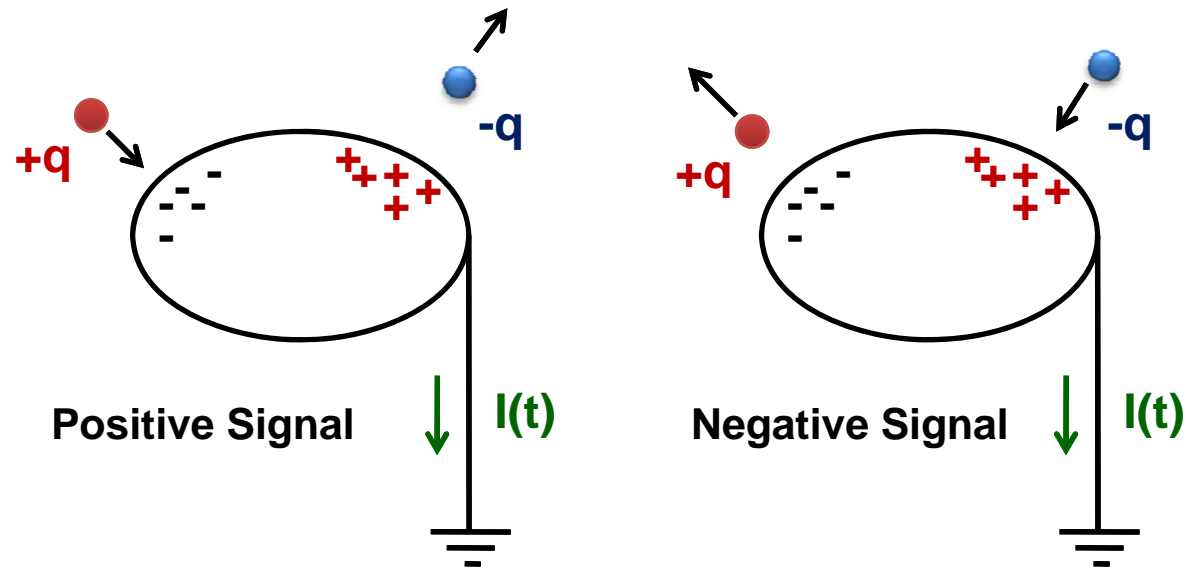

The definition of $I=-dQ/dt$ states that the positive current is pointing away from the electrode.

The signal is positive if:

Positive charge is moving from electrode to ground or
Negative charge is moving from ground to the electrode

The signal is negative if:

Negative charge is moving from electrode to ground or
Positive charge is moving from ground to the electrode

Signal Polarity Definition

$$I(t) = -\frac{dQ(t)}{dt}$$

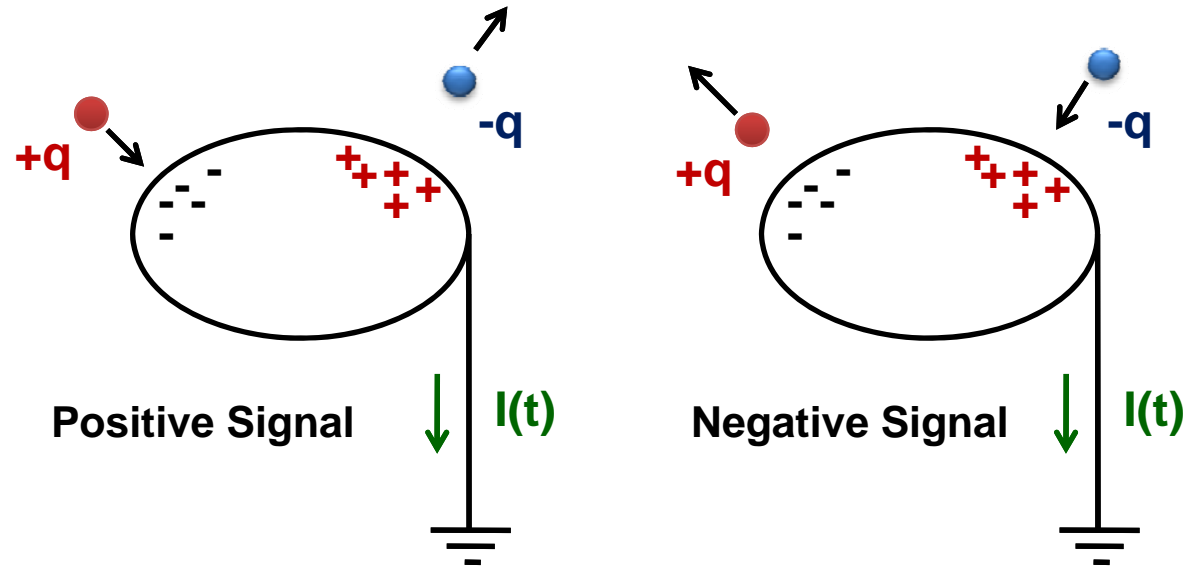

By this we can guess the signal polarities:

In a wire chamber, the electrons are moving towards the wire, which means that they attract positive charges that are moving from ground to the electrode. The signal of a wire that collects electrons is therefore negative.

Sum of Induced Charges and Currents

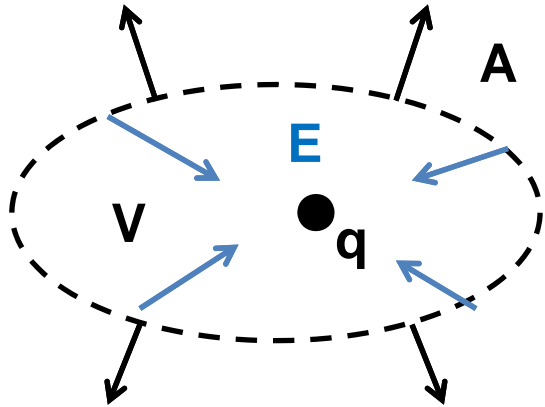

$$\oint_{\vec{A}} \vec{E} d\vec{A} = \frac{1}{\epsilon_0} \int_V \rho dV = \frac{q}{\epsilon_0}$$

The surface A must be oriented towards the outside of the volume V.

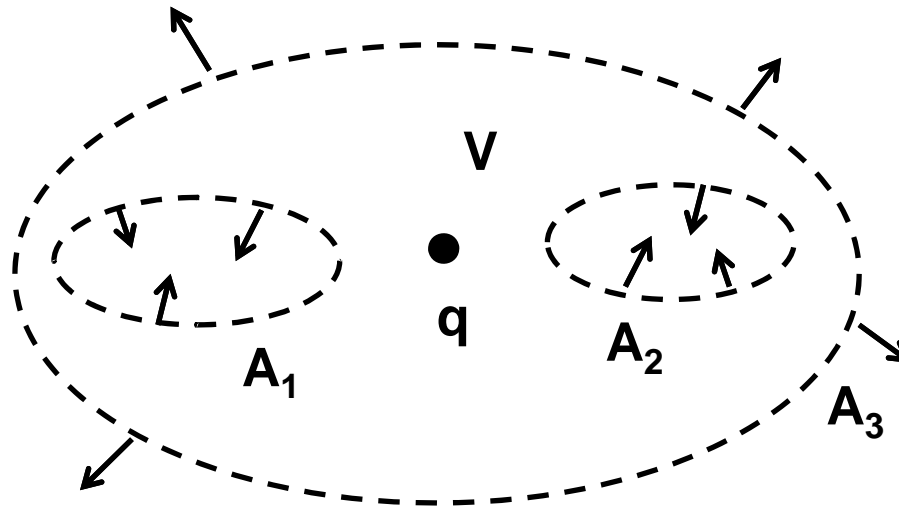

$$\mathbf{A} = \mathbf{A}_1 + \mathbf{A}_2 + \mathbf{A}_3$$

$$\oint_{\vec{A}} \vec{E} d\vec{A} = \oint_{\vec{A}_1} \vec{E} d\vec{A} + \oint_{\vec{A}_2} \vec{E} d\vec{A} + \oint_{\vec{A}_3} \vec{E} d\vec{A} = \frac{q}{\epsilon_0}$$

Sum of Induced Charges and Currents

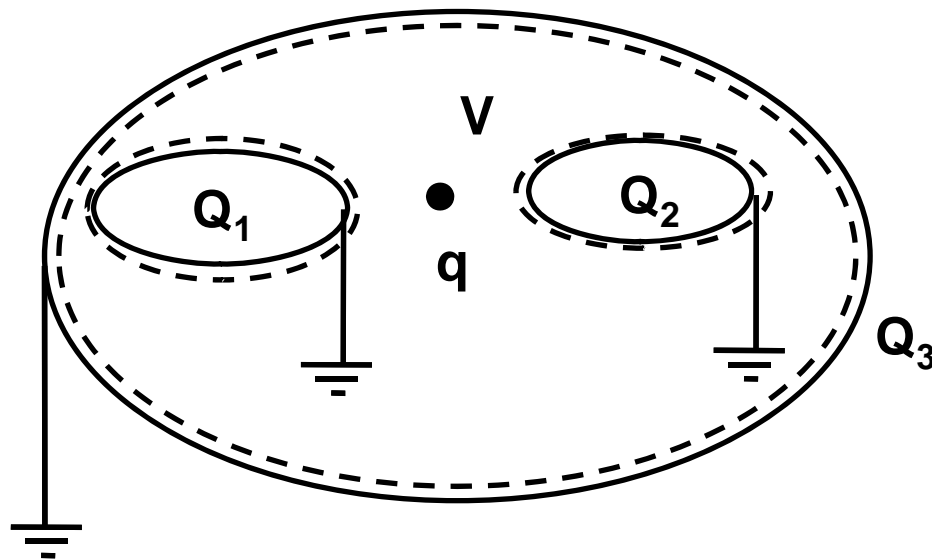

$$\oint_{\vec{A}} \vec{E} d\vec{A} = \oint_{\vec{A}_1} \vec{E} d\vec{A} + \oint_{\vec{A}_2} \vec{E} d\vec{A} + \oint_{\vec{A}_3} \vec{E} d\vec{A} = \frac{q}{\epsilon_0}$$

In case the surfaces are metal electrodes we know that

$$Q_1 = - \oint_{\vec{A}_1} \epsilon_0 \vec{E} d\vec{A} \quad Q_2 = - \oint_{\vec{A}_2} \epsilon_0 \vec{E} d\vec{A} \quad Q_3 = - \oint_{\vec{A}_3} \epsilon_0 \vec{E} d\vec{A}$$

And we therefore have

$$Q_1 + Q_2 + Q_3 = -q$$

In case there is one electrode enclosing all the others, the sum of all induced charges is always equal to the point charge.

The sum of all induced currents is therefore zero at any time !

Charged Electrodes

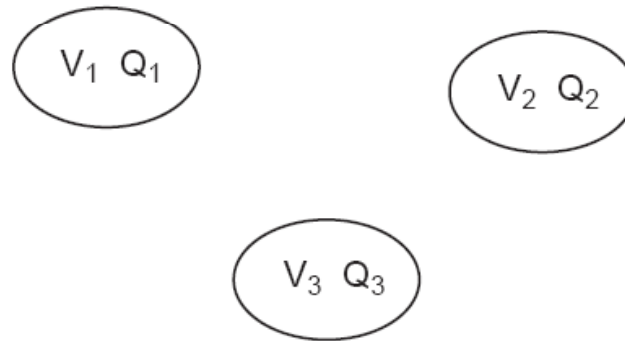

Setting the three electrodes to potentials V_1, V_2, V_3 results in charges Q_1, Q_2, Q_3 . In order to find them we have to solve the Laplace equation

$$\Delta\varphi = 0$$

with boundary condition

$$\varphi|_{\vec{A}_1} = V_1 \quad \varphi|_{\vec{A}_2} = V_2 \quad \varphi|_{\vec{A}_3} = V_3$$

And then calculate

$$Q_1 = \oint_{\vec{A}_1} -\vec{\nabla}\varphi d\vec{A} \quad Q_2 = \oint_{\vec{A}_2} -\vec{\nabla}\varphi d\vec{A} \quad Q_3 = \oint_{\vec{A}_3} -\vec{\nabla}\varphi d\vec{A}$$

Green's Second Theorem

Gauss Law which is valid for Vector Field and Volume V surrounded by the Surface A:

$$\oint_{\vec{A}} \vec{E} d\vec{A} = \int_V \vec{\nabla} \cdot \vec{E} dV$$

By setting

$$\vec{E} = \varphi \vec{\nabla} \psi \quad \oint_{\vec{A}} \varphi \vec{\nabla} \psi d\vec{A} = \int_V \vec{\nabla} \varphi \cdot \vec{\nabla} \psi dV + \int_V \varphi \Delta \psi dV$$

and setting

$$\vec{E} = \psi \vec{\nabla} \varphi \quad \oint_{\vec{A}} \psi \vec{\nabla} \varphi d\vec{A} = \int_V \vec{\nabla} \psi \cdot \vec{\nabla} \varphi dV + \int_V \psi \Delta \varphi dV$$

and subtracting the two expressions we get Green's second theorem:

$$\oint_{\vec{A}} (\varphi \vec{\nabla} \psi - \psi \vec{\nabla} \varphi) d\vec{A} = \int_V (\varphi \Delta \psi - \psi \Delta \varphi) dV$$

Green's Theorem, Reciprocity

$$V_1 \quad Q_1$$

$$V_2 \quad Q_2$$

$$V_3 \quad Q_3$$

$$\Delta\varphi = 0$$

$$\bar{V}_1 \quad \bar{Q}_1$$

$$\bar{V}_2 \quad \bar{Q}_2$$

$$\bar{V}_3 \quad \bar{Q}_3$$

$$\Delta\psi = 0$$

$$\varphi|_{\bar{A}_1} = V_1 \quad \varphi|_{\bar{A}_2} = V_2 \quad \varphi|_{\bar{A}_3} = V_3$$

$$\psi|_{\bar{A}_1} = \bar{V}_1 \quad \psi|_{\bar{A}_2} = \bar{V}_2 \quad \psi|_{\bar{A}_3} = \bar{V}_3$$

$$Q_1 = \oint_{\bar{A}_1} -\vec{\nabla}\varphi d\vec{A} \quad Q_2 = \oint_{\bar{A}_2} -\vec{\nabla}\varphi d\vec{A} \quad Q_3 = \oint_{\bar{A}_3} -\vec{\nabla}\varphi d\vec{A}$$

$$\bar{Q}_1 = \oint_{\bar{A}_1} -\vec{\nabla}\psi d\vec{A} \quad \bar{Q}_2 = \oint_{\bar{A}_2} -\vec{\nabla}\psi d\vec{A} \quad \bar{Q}_3 = \oint_{\bar{A}_3} -\vec{\nabla}\psi d\vec{A}$$

$$\oint_{\bar{A}} (\varphi \vec{\nabla}\psi - \psi \vec{\nabla}\varphi) d\vec{A} = \oint_V (\varphi \Delta\psi - \psi \Delta\varphi) dV$$



$$\sum_{n=1}^N Q_n \bar{V}_n = \sum_{n=1}^N \bar{Q}_n V_n$$

Reciprocity Theorem

It related two electrostatic states, i.e. two sets of voltages and charges

Electrostatics, Capacitance Matrix

From the reciprocity theorem it follows that the voltages of the electrodes and the charges on the electrodes are related by a matrix

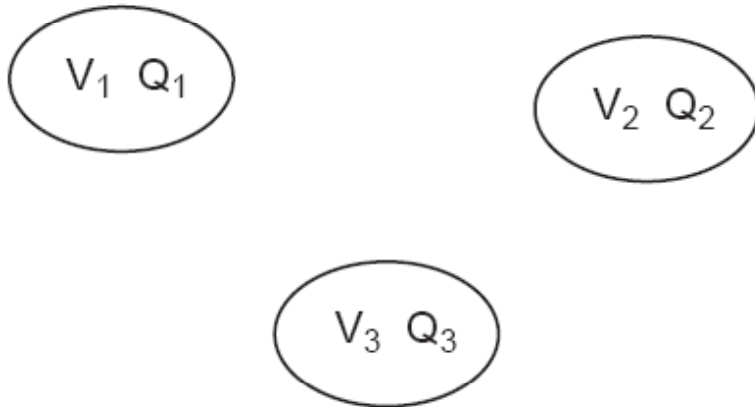

$$Q_n = \sum_{m=1}^N c_{nm} V_m$$

The matrix c_{nm} is called the capacitance matrix with the important properties

$$c_{nm} = c_{mn} \quad c_{nm} < 0 \quad \sum_{m=1}^N c_{nm} > 0$$

The capacitance matrix elements are not to be confused with the electrode capacitances of the equivalent circuit. They are related by

$$C_{nm} = -c_{nm} \quad n \neq m \quad C_{nn} = \sum_{m=1}^N c_{nm}$$

Induced Charge

We assume three grounded electrodes and a point charge in between. We want to know the charges induced on the grounded electrodes. We assume the point charge to be an very small metal electrode with charge q , so we have a system of 4 electrodes with $V_1=0$, $V_2=0$, $V_3=0$, $Q_0=q$.

We can now assume another set of voltages and charges where we remove the charge from electrode zero, we put electrode 1 to voltage V_w and keep electrodes 2 and 3 grounded.

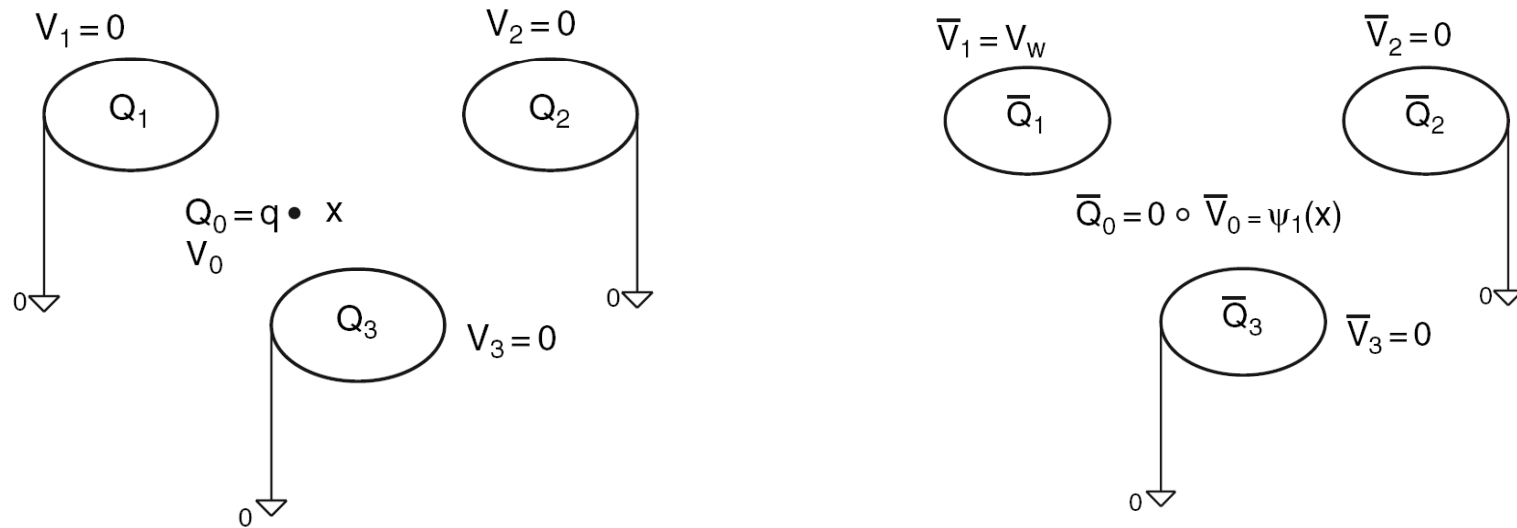

Using the reciprocity theorem $\sum_{n=1}^N Q_n \bar{V}_n = \sum_{n=1}^N \bar{Q}_n V_n$ we get

$$q \bar{V}_0 + Q_1 V_w = 0 \quad \rightarrow \quad Q_1 = -q \frac{\bar{V}_0}{V_w} .$$

Induced Charge

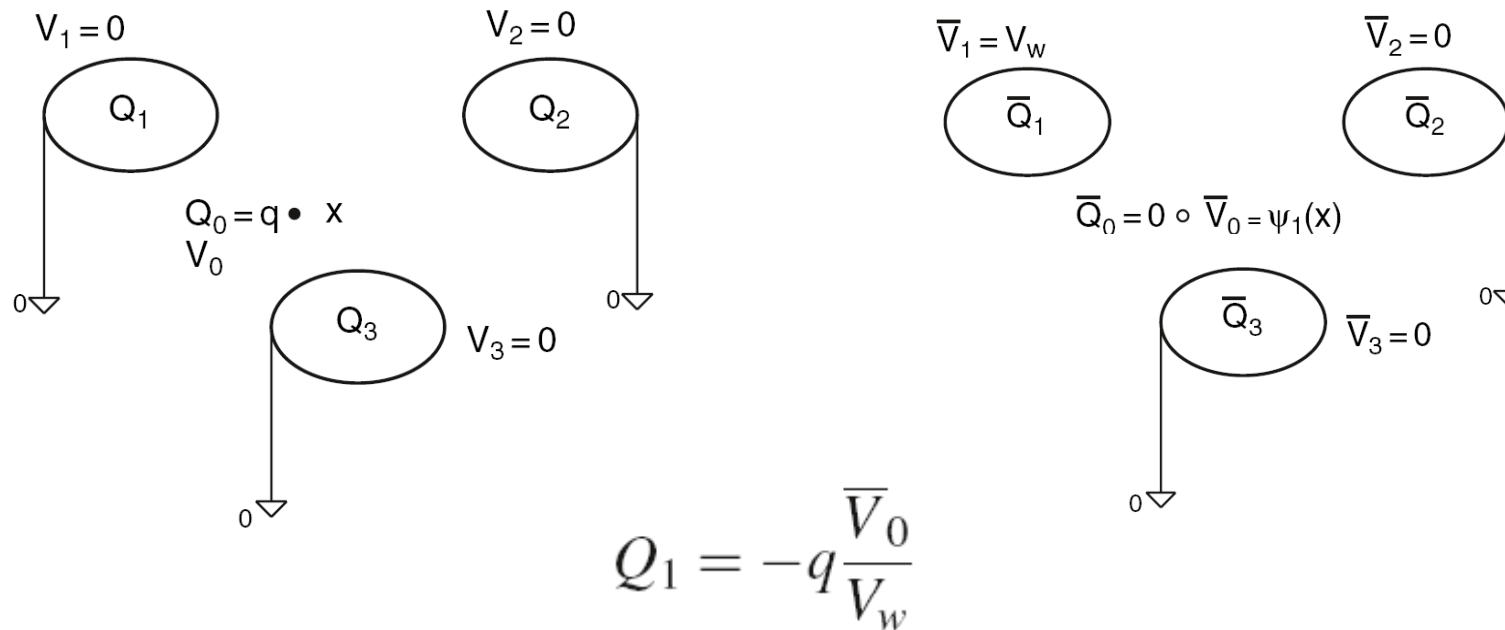

The voltage \bar{V}_0 is the voltage of the small uncharged electrode for the second electrostatic state, and because a small uncharged electrode is equal to having no electrode, \bar{V}_0 is the voltage at the place x of the point charge in case the charge is removed, electrode 1 is put to voltage V_w and the other electrodes are grounded.

We call the potential $\psi_1(x)$ the weighting potential of electrode 1.

Induced Charge

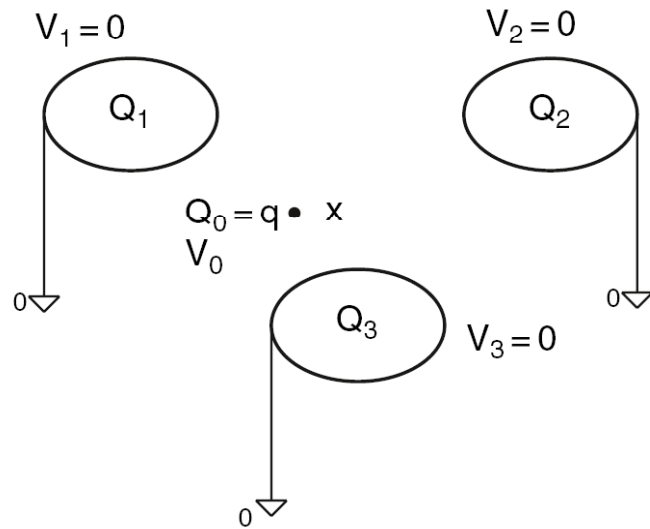

$$Q = -\frac{q}{V_w} \psi(\vec{x})$$

The charge induced by a point charge q at position x on a grounded electrode can be calculated the following way: One removes the point charge, puts the electrode in question to potential V_w while keeping the other electrodes grounded.

This defines the potential 'weighting potential' $\psi(x)$ from which the induced charge can be calculated by the above formula.

Induced Current, Ramo Schottky Theorem

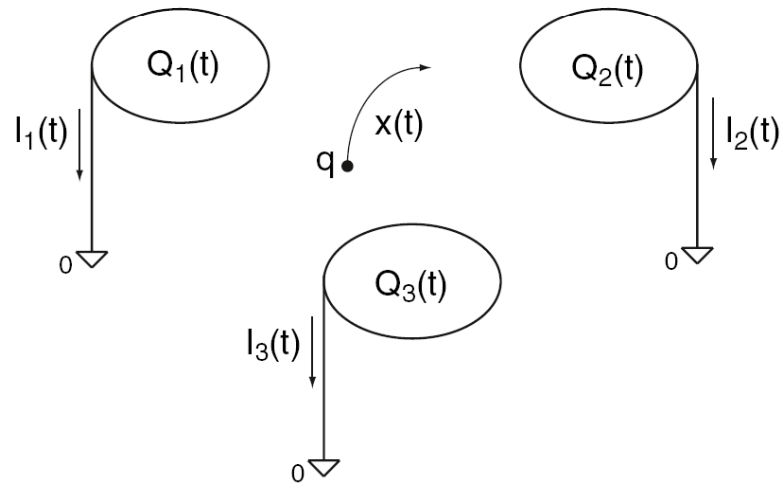

$$Q = -\frac{q}{V_w} \psi(\vec{x})$$

In case the charge is moving along a trajectory $x(t)$, the time dependent induced charge is

$$Q(t) = -\frac{q}{V_w} \psi(\vec{x}(t))$$

And the induced current is

$$I(t) = -\frac{dQ}{dt} = \frac{q}{V_w} \vec{\nabla} \psi(\vec{x}(t)) \frac{d\vec{x}(t)}{dt} = -\frac{q}{V_w} \vec{E}(\vec{x}(t)) \vec{v}(t)$$

Induced Charge

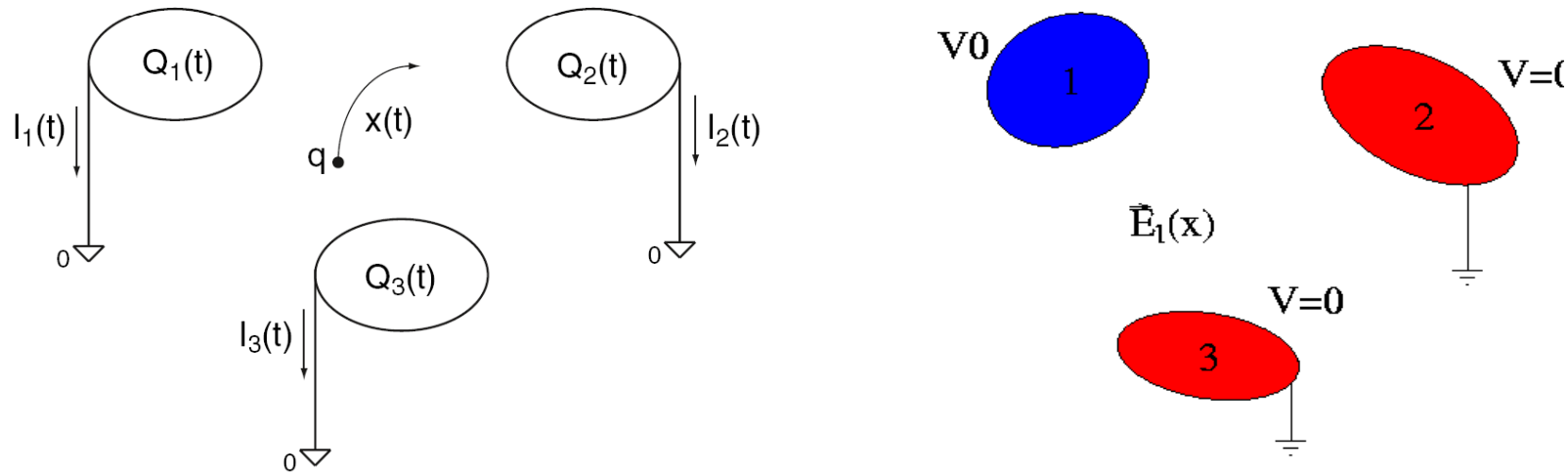

The current induced on a grounded electrode n by a moving point charge q is given by

$$I_n(t) = -\frac{q}{V_w} \vec{E}_n(\vec{x}(t)) \cdot \vec{v}(t)$$

Where the weighting field E_n is defined by removing the point charge, setting the electrode in question to potential V_w and keeping the other electrodes grounded.

Removing the charge means that we just have to solve the Laplace equation and not the Poisson equation !

Parallel Plate Chamber

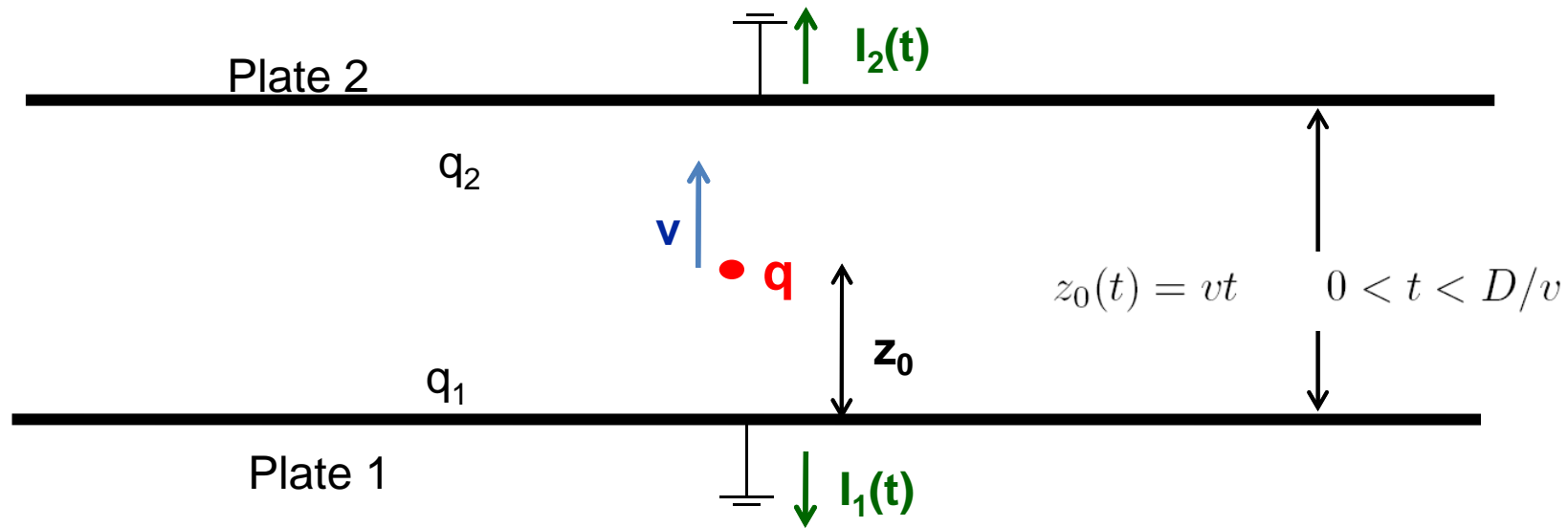

Weighting field E_1 of plate 1: Remove charge, set plate1 to V_w and keep plate2 grounded

$$E_1 = \frac{V_w}{D}$$

Weighting field E_2 of plate 2: Remove charge, set plate2 to V_w and keep plate1 grounded

$$E_2 = -\frac{V_w}{D}$$

So we have the induced currents

$$I_1 = -\frac{q}{V_w} \frac{V_w}{D} E_1 v = -\frac{qv}{D} \quad I_2 = -\frac{q}{V_w} \frac{V_w}{D} E_2 v = \frac{qv}{D}$$

Arguing with Energy ? Not a good Idea !

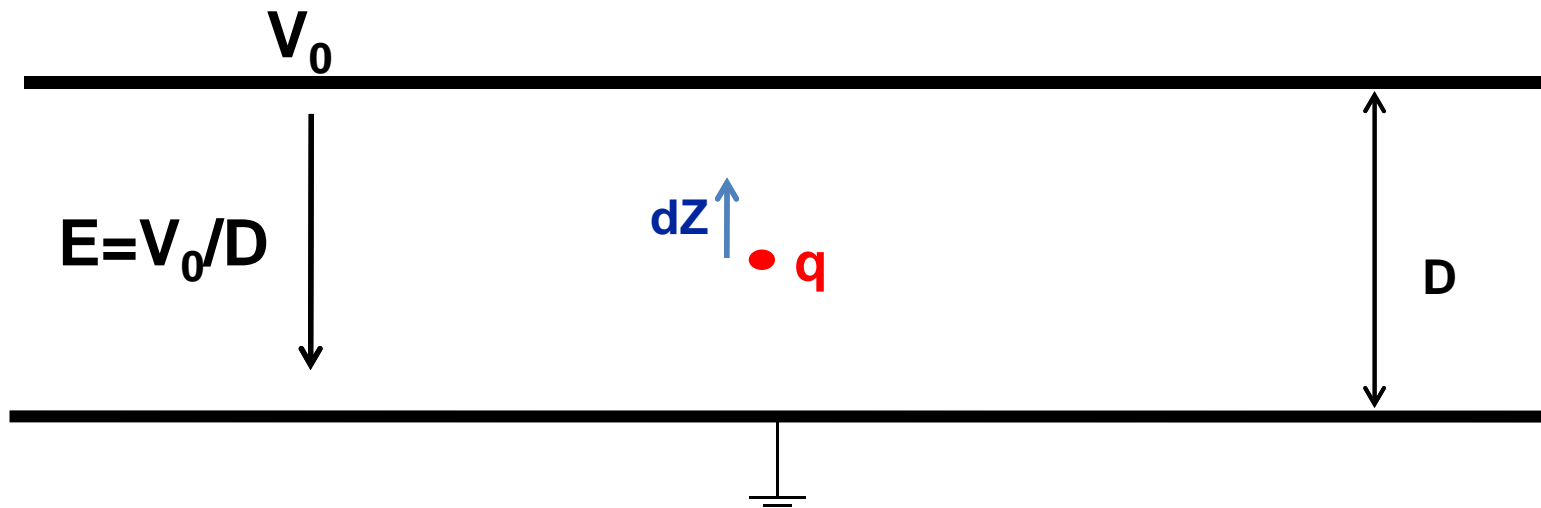

$$Energy = \frac{1}{2} C V_0^2 = \frac{1}{2} \frac{Q^2}{C}$$

$$dW = q E dz = \frac{q V_0}{D} dz$$

$$d(Energy) = dW$$

$$d \frac{1}{2} \frac{Q^2}{C} = \frac{q V_0}{D} dz$$

$$\frac{1}{2} \frac{1}{C} Q dQ = \frac{q V_0}{D} dz$$

$$dQ = \frac{q}{D} dz$$

This argument gives the correct result, it is however only correct for a 2 electrode system because there the weighting field and the real field are equal. In addition the argument is very misleading.

Arguing with Energy ? Not a good Idea !

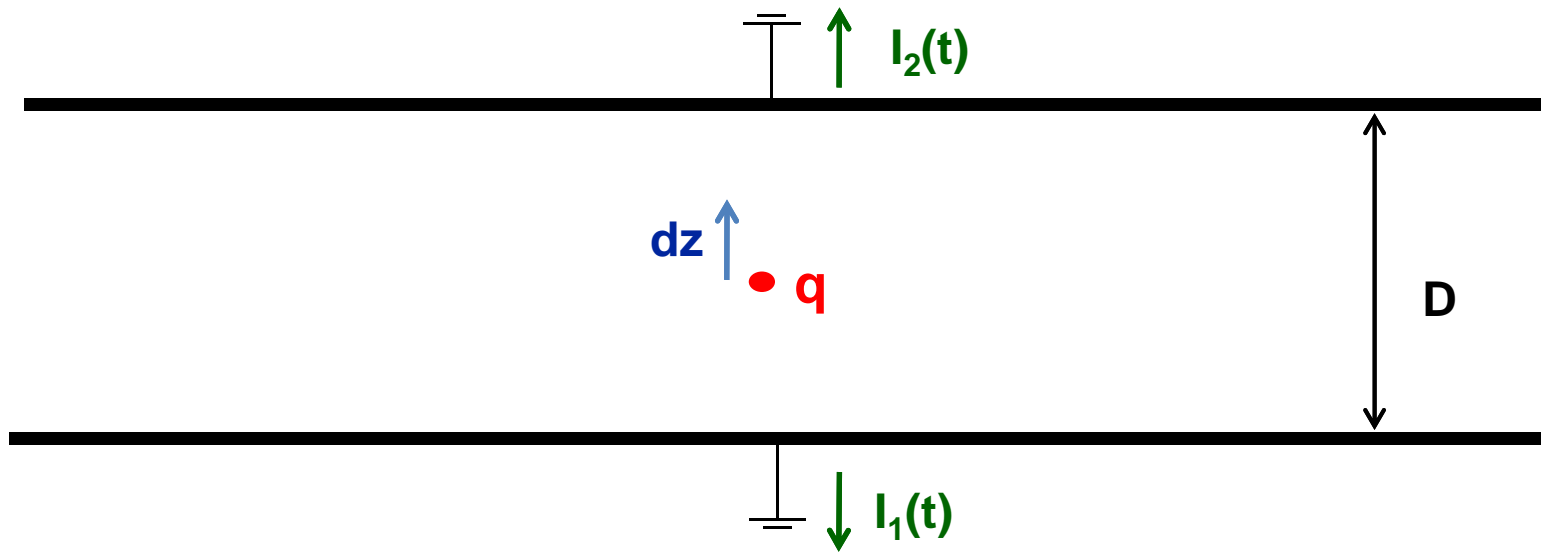

An induced current signal has nothing to do with Energy. In a gas detector the electrons are moving at constant speed in a constant electric field, so the energy gained by the electron in the electric field is lost into collisions with the gas, i.e. heating of the gas.

In absence of an electric field, the charge can be moved across the gap without using any force and currents are flowing.

The electric signals are due to induction !

Total Induced Charge

If a charge is moving from point \mathbf{x}_0 to point \mathbf{x}_1 , the induced charge is

$$Q_n^{ind} = \int_{t_0}^{t_1} I_n^{ind}(t) dt = -\frac{q}{V_w} \int_{t_0}^{t_1} \mathbf{E}_n[\mathbf{x}(t)] \dot{\mathbf{x}}(t) dt = \frac{q}{V_w} [\psi_n(\mathbf{x}_1) - \psi_n(\mathbf{x}_0)]$$

If a pair of charges $+q$ and $-q$ is produced at point \mathbf{x}_0 and q moves to \mathbf{x}_1 while $-q$ moves to \mathbf{x}_2 , the charge induced on electrode n is given by

$$Q_n^{ind} = \int_{t_0}^{t_1} I_n^{ind}(t) dt = \frac{q}{V_w} [\psi_n(\mathbf{x}_1) - \psi_n(\mathbf{x}_2)]$$

If the charge q moves to electrode n while the charge $-q$ moves to another electrode, the total induced charge on electrode n is q , because the ψ_n is equal to V_w on electrode n and equal to zero on all other electrodes.

In case both charges go to different electrodes the total induced charge is zero.

After ALL charges have arrived at the electrodes, the total induced charge on a given electrode is equal to the charge that has ARRIVED at this electrode.

Current signals on electrodes that don't receive a charge are therefore strictly bipolar.

Induced Charge, 'Collected' Charge

The fact that the total induced charge on an electrode, once ALL charges have arrived at the electrodes, is equal to the actual charge that has ARRIVED at the electrode, leads to very different 'vocabulary for detectors in different detectors.

In wire chambers the ions take hundreds of microseconds to arrive at the cathodes. Because the electronics 'integration time' is typically much shorter than this time, the reality that the signal is 'induced' is very well known for wire chambers, and the signal shape is dominated by the movement of the ions.

The longer the amplifier integration time, the more charge is integrated, which is sometimes called 'collected', but it has nothing to do with collecting charge from the detector volume ...

In Silicon Detectors, the electrons and holes take only a few ns to arrive at their electrodes, so e.g. for typical 'integration times' of amplifiers of 25ns, the shape is dominated by the amplifier response. The peak of the amplifier output is the proportional to the primary charge, and all the charge is 'collected'

Still, the signal is not due to charges entering the amplifier from the detector, it is due to induction by the moving charge. Once the charge has actually arrived at the electrode, the signal is over !

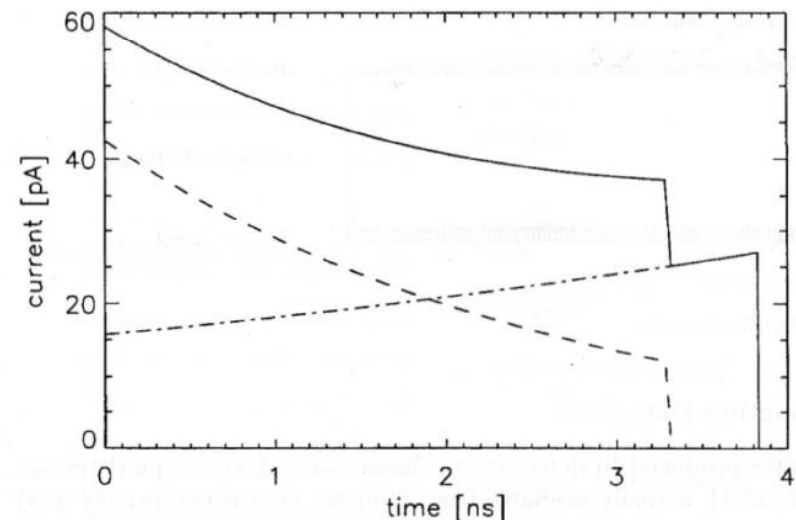
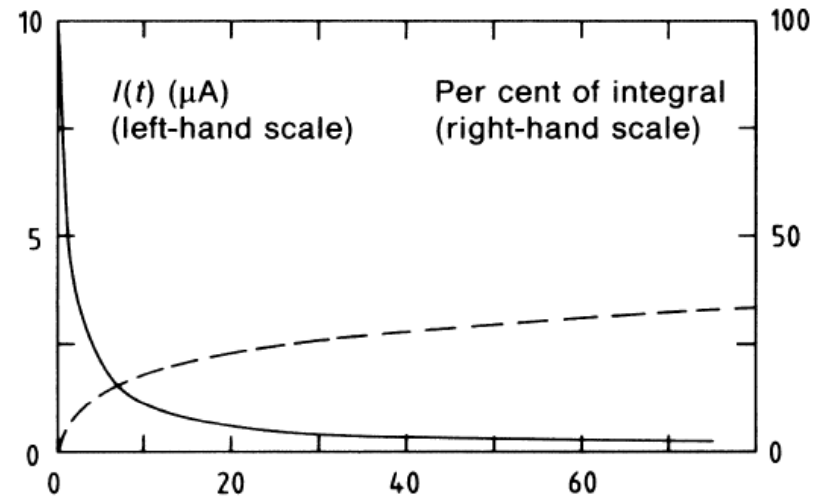

Total Induced Charge

Imagine avalanche in a drift tube, caused by a single electron.

Let's assume that the gas gain is 10^4 .

We read out the wire signal with an ideal integrator

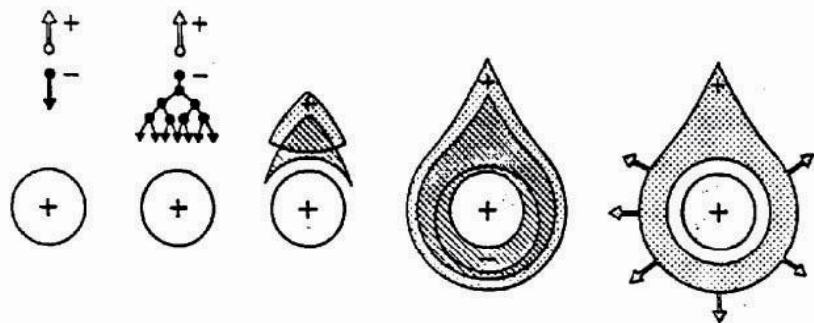

The 10^4 electrons arrive at the wire within $<1\text{ns}$, so the integrator should instantly see the full charge of $-10^4 e_0$ electrons ?

No ! The ions close to the wire induce the opposite charge on the wire, so in the very beginning there is zero charge on the integrator and only once the ions have moved away from the wire the integrator measures the full $-10^4 e_0$

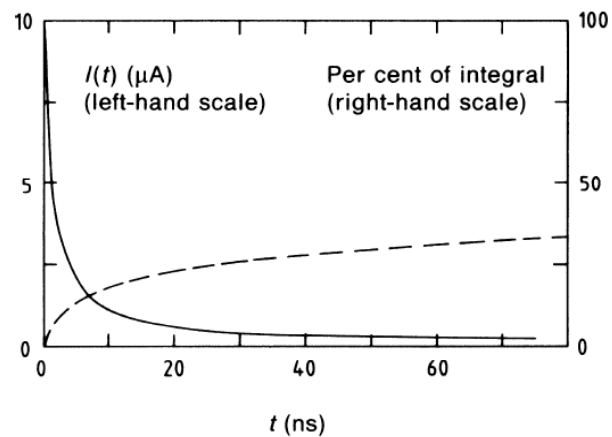
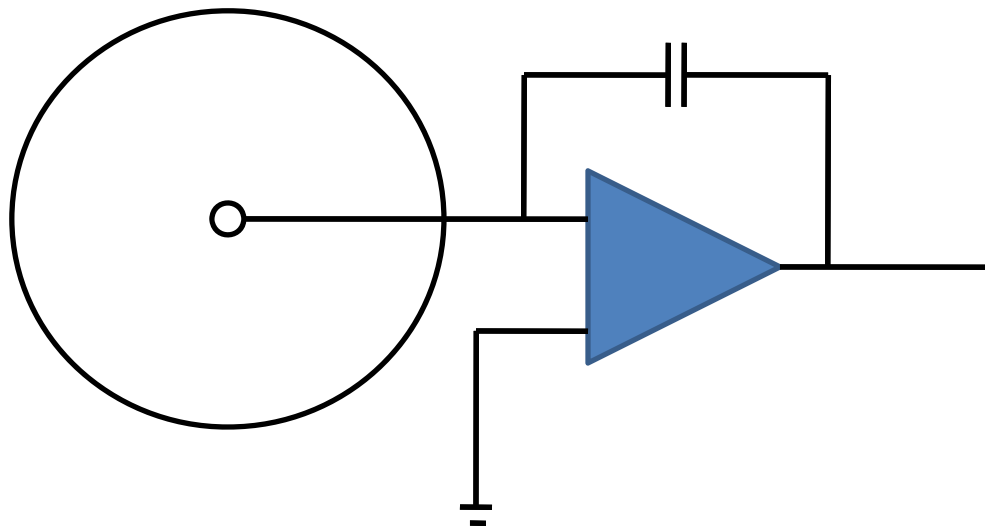

Signal Calculation in 3 Steps

What are the signals induced by a moving charge on electrodes that are connected with arbitrary linear impedance elements ?

- 1) Calculate the particle trajectory in the 'real' electric field.
- 2) Remove all the impedance elements, connect the electrodes to ground and calculate the currents induced by the moving charge on the grounded electrodes.

The current induced on a grounded electrode by a charge q moving along a trajectory $x(t)$ is calculated the following way (Ramo Theorem):

One removes the charge q from the setup, puts the electrode to voltage V_0 while keeping all other electrodes grounded. This results in an electric field $E_n(x)$, the Weighting Field, in the volume between the electrodes, from which the current is calculated by

$$I_n(t) = -\frac{q}{V_0} \vec{E}_n[\vec{x}(t)] \frac{d\vec{x}(t)}{dt} = -\frac{q}{V_0} \vec{E}_n[\vec{x}(t)] \vec{v}(t)$$

- 3) These currents are then placed as ideal current sources on a circuit where the electrodes are 'shrunk' to simple nodes and the mutual electrode capacitances are added between the nodes. These capacitances are calculated from the weighting fields by

$$c_{nm} = \frac{\epsilon_0}{V_w} \oint_{A_n} \vec{E}_m(x) dA \quad C_{nn} = \sum_m c_{nm} \quad C_{nm} = -c_{nm} \quad n \neq m$$

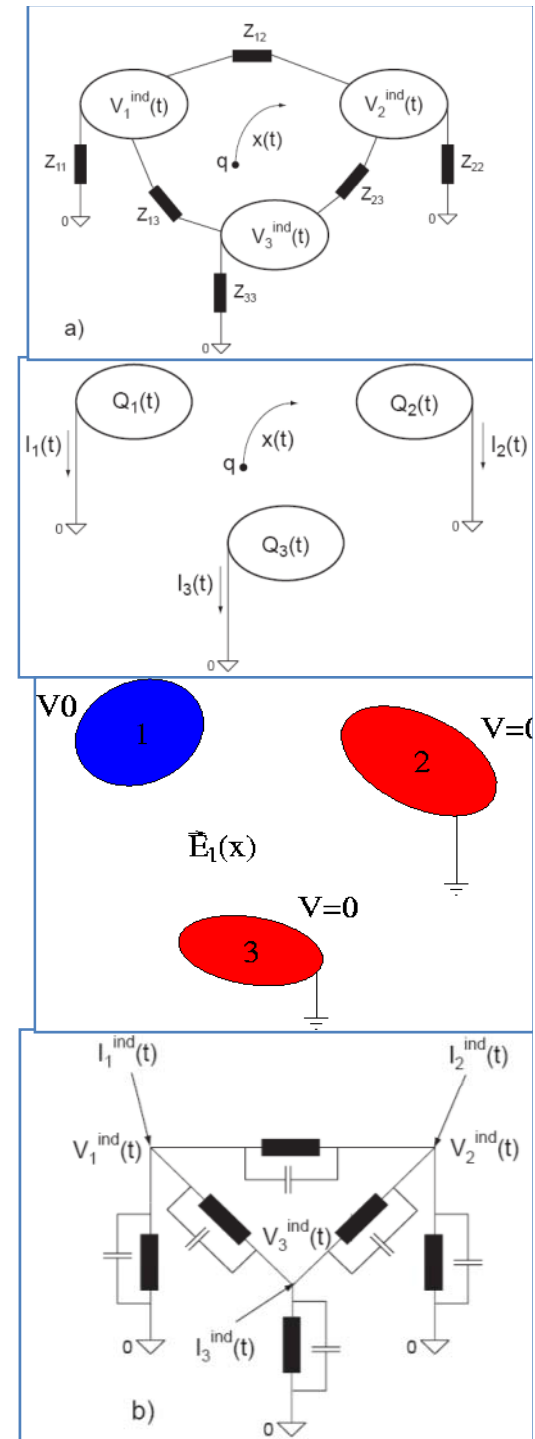

General Signal Theorems

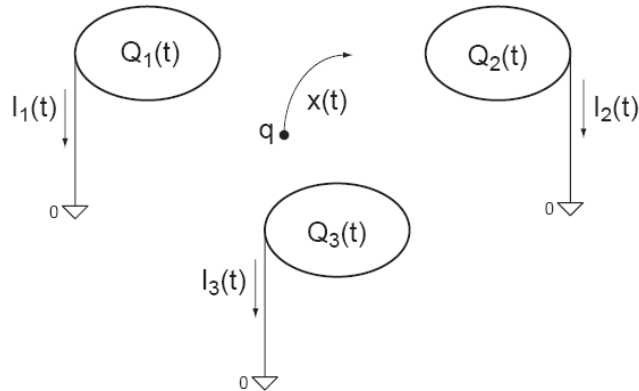

The following relations hold for the induced currents:

1) The charge induced on an electrode in case a charge in between the electrode has moved from a point x_0 to a point x_1 is

$$Q_n^{ind} = \int_{t_0}^{t_1} I_n^{ind}(t) dt = -\frac{q}{V_w} \int_{t_0}^{t_1} \mathbf{E}_n[\mathbf{x}(t)] \dot{\mathbf{x}}(t) dt = \frac{q}{V_w} [\psi_n(\mathbf{x}_1) - \psi_n(\mathbf{x}_0)]$$

and is independent on the actual path.

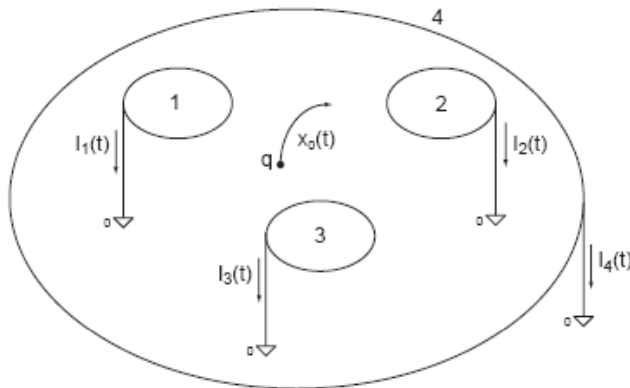

2) Once ALL charges have arrived at the electrodes, the total induced charge in the electrodes is equal to the charge that has ARRIVED at this electrode.

3) In case there is one electrode enclosing all the others, the sum of all induced currents is zero at any time.

Signals in a Parallel Plate Geometry

E.g.: Electron-ion pair in gas
 or Electron-ion pair in a liquid
 or Electron-hole pair in a solid

$$E_1 = V_0/D$$

$$E_2 = -V_0/D$$

$$I_1 = -(-q)/V_0 * (V_0/D) * v_e - q/V_0 (V_0/D) (-v_i)$$

$$= q/D * v_e + q/D * v_i$$

$$I_2 = -I_1$$

$$Q_1^{\text{tot}} = \int I_1 dt = q/D * v_e T_e + q/D * v_i T_i$$

$$= q/D * v_e * (D - z_0)/v_e + q/D * v_i * z_0/v_i$$

$$= q(D - z_0)/D + qz_0/D =$$

$$q_e + q_i = q$$

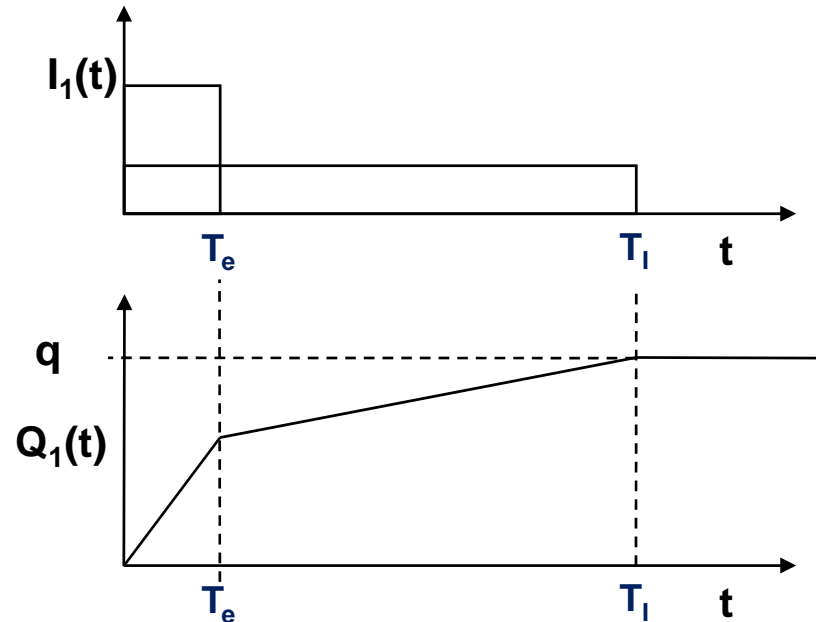
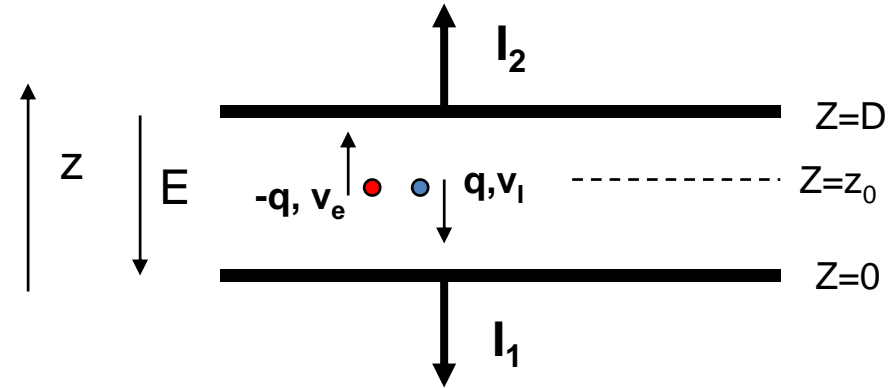

The total induced charge on a specific electrode, once all the charges have arrived at the electrodes, is equal to the charge that has arrived at this specific electrode.

Wire Chamber Signals

Wire with radius (10-25 μm) in a tube of radius b (1-3cm):

$$E(r) = \frac{\lambda}{2\pi\epsilon_0 r} = \frac{V_0}{\ln \frac{b}{a}} \frac{1}{r}, \quad V(r) = \frac{V_0}{\ln \frac{b}{a}} \ln \frac{r}{a},$$

Electric field close to a thin wire (100-300kV/cm). E.g. $V_0=1000\text{V}$, $a=10\mu\text{m}$, $b=10\text{mm}$, $E(a)=150\text{kV/cm}$

Electric field is sufficient to accelerate electrons to energies which are sufficient to produce secondary ionization \rightarrow electron avalanche \rightarrow signal.

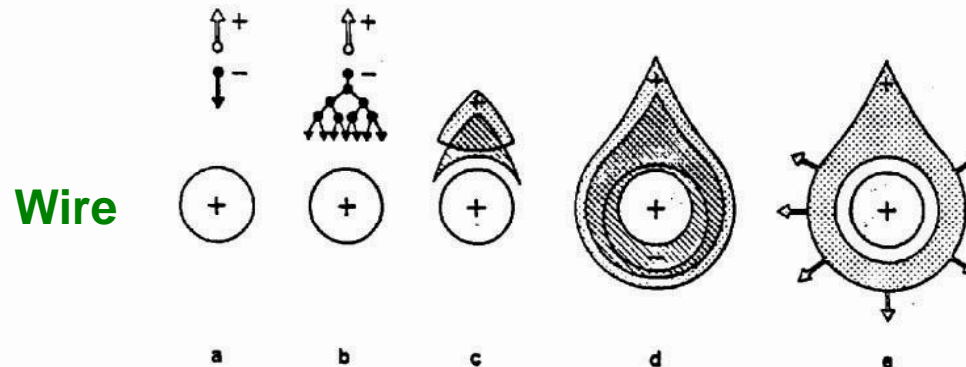
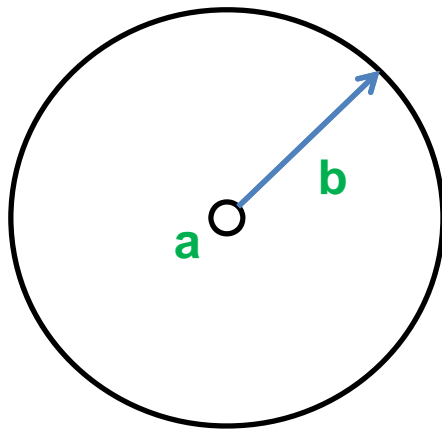

Wire Chamber Signals

The electrons are produced very close to the wire, so for now we assume that N_{tot} ions are moving from the wire surface to the tube wall

$$E(r) = \frac{\lambda}{2\pi\epsilon_0 r} = \frac{U}{\ln \frac{b}{a}}, \quad V(r) = \frac{U}{\ln \frac{b}{a}} \ln \frac{r}{a},$$

Ions move with a velocity proportional to the electric field.

$$v = \mu E$$

$$\frac{dr(t)}{dt} = \mu \frac{U}{r(t) \ln(b/a)} \rightarrow r(t) = a \sqrt{1 + \frac{t}{t_0}} \quad t_0 = \frac{a^2 \ln(b/a)}{2\mu U}$$

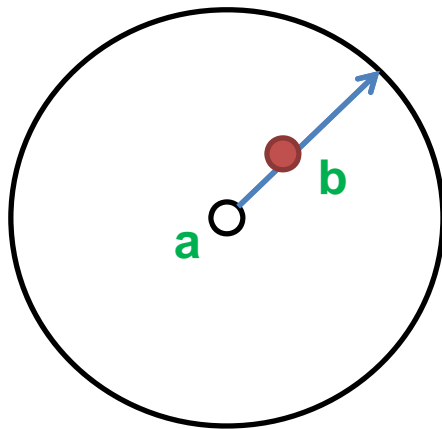

Weighting Field of the wire: Remove charge and set wire to V_w while grounding the tube wall.

$$E_1(r) = \frac{V_w}{r \ln(b/a)}$$

The induced current is therefore

$$I_1^{ind}(t) = -\frac{N_{tot}e_0}{V_w} E_1[r(t)] \dot{r}(t) = -\frac{N_{tot}e_0}{2 \ln(b/a)} \frac{1}{t + t_0}.$$

Wire Chamber Signals

$$I_1^{ind}(t) = -\frac{N_{tot}e_0}{V_w} E_1[r(t)] \dot{r}(t) = -\frac{N_{tot}e_0}{2\ln(b/a)} \frac{1}{t+t_0}$$

$$Q_1^{ind}(t) = \int_0^t I_1^{ind}(t') dt' = -\frac{N_{tot}e_0}{2\ln(b/a)} \ln\left(1 + \frac{t}{t_0}\right)$$

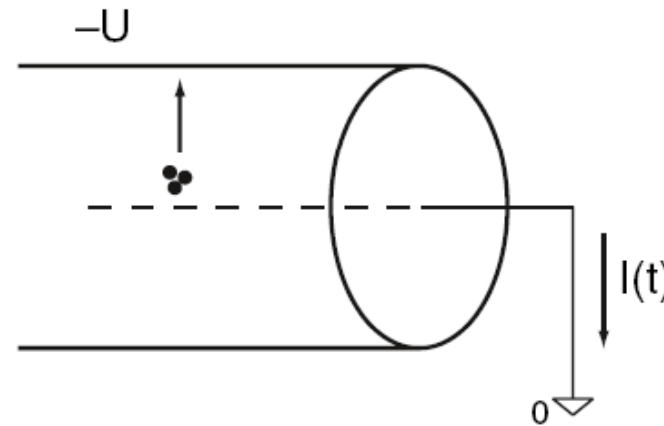
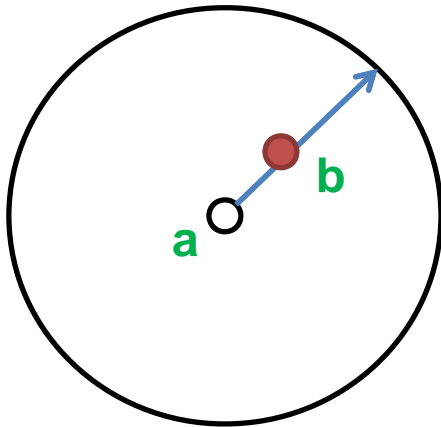
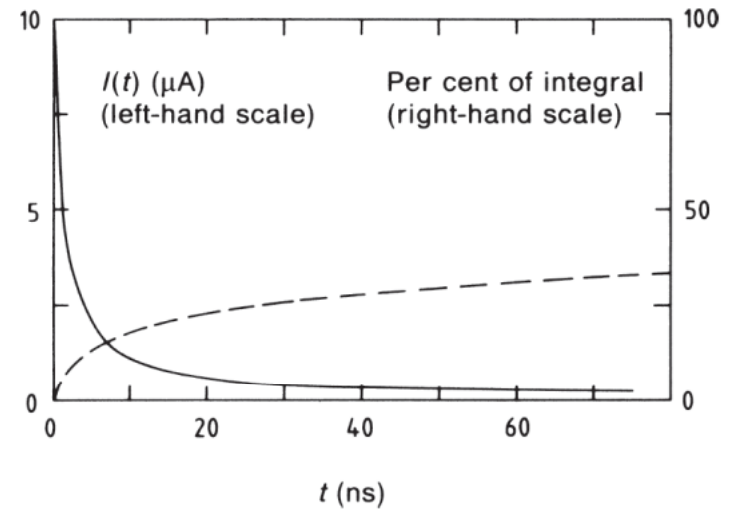

Silicon Detector Signals

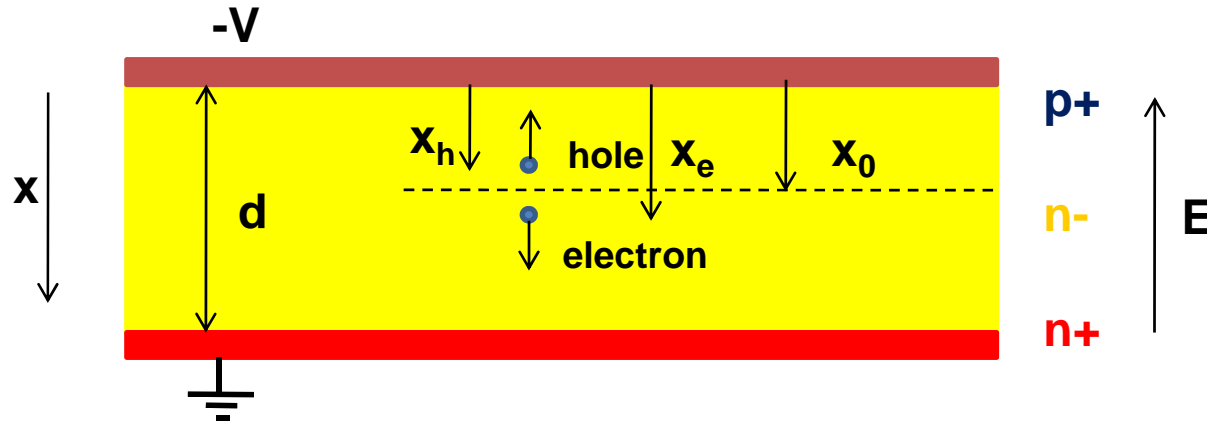

What is the signal induced on the p+ 'electrode' for a single e/h pair created at $x_0=d/2$ for a 300um Si detector ?

$$E(x) = - \left[2 \frac{d-x}{d^2} V_{dep} + \frac{V - V_{dep}}{d} \right] \quad v_e(x) = \mu_e E(x) \quad v_h(x) = \mu_h E(x)$$

$$\frac{dx_e(t)}{dt} = \mu_e E(x(t)) \quad x_e(t) = d \frac{V + V_{dep}}{2V_{dep}} + \left[x_0 - d \frac{V + V_{dep}}{2V_{dep}} \right] e^{-2\mu_e V_{dep} t / d^2}$$

$$\frac{dx_e(t)}{dt} = \mu_e \left[\frac{2V_{dep}}{d^2} x_0 - \frac{V + V_{dep}}{d} e^{-2\mu_e V_{dep} t / d^2} \right]$$

$$\frac{dx_h(t)}{dt} = -\mu_h E(x(t)) \quad x_h(t) = d \frac{V + V_{dep}}{2V_{dep}} + \left[x_0 - d \frac{V + V_{dep}}{2V_{dep}} \right] e^{2\mu_h V_{dep} t / d^2}$$

$$\frac{dx_h(t)}{dt} = \mu_h \left[\frac{2V_{dep}}{d^2} x_0 - \frac{V + V_{dep}}{d} e^{2\mu_h V_{dep} t / d^2} \right]$$

Silicon Detector Signals

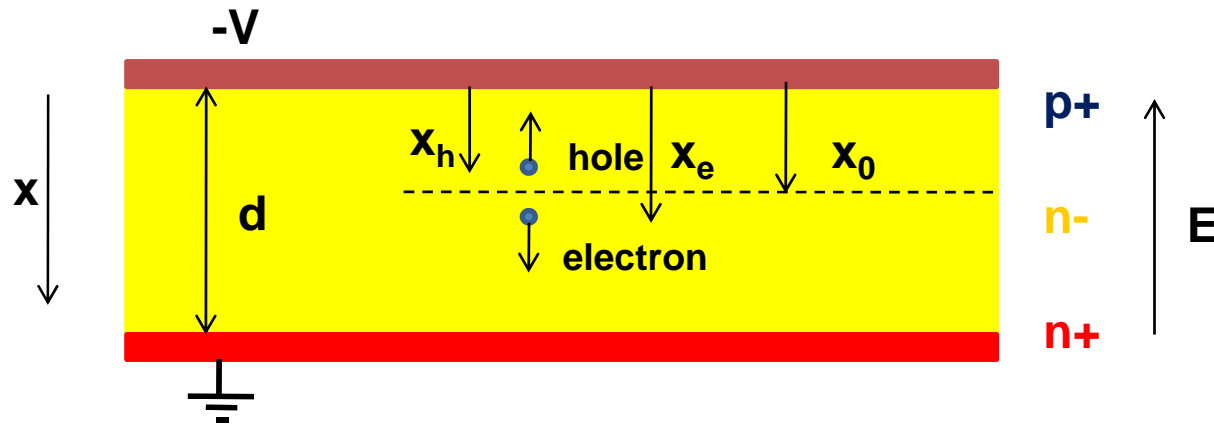

$$x_e(t_e) = d \quad t_e = \frac{d^2}{2\mu_e V_{dep}} \ln \left[\frac{V + V_{dep}}{V - V_{dep}} \left(1 - \frac{x_0}{d} \frac{2V_{dep}}{V + V_{dep}} \right) \right]$$

$$x_h(t_h) = 0 \quad t_h = -\frac{d^2}{2\mu_e V_{dep}} \ln \left(1 - \frac{x_0}{d} \frac{2V_{dep}}{V + V_{dep}} \right)$$

$$E_w(x) = \frac{V_w}{d} \quad i(t) = -\frac{q}{V_w} E_w(x(t)) \frac{dx(t)}{dt}$$

$$i(t) = i_e(t) + i_h(t) = \frac{e_0}{d} \frac{dx_e(t)}{dt} - \frac{e_0}{d} \frac{dx_h(t)}{dt}$$

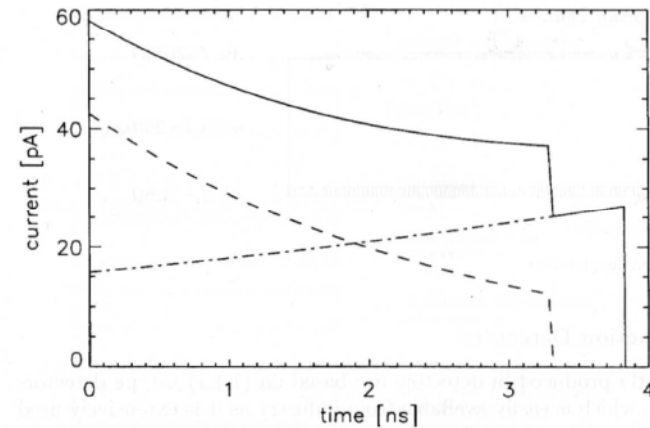
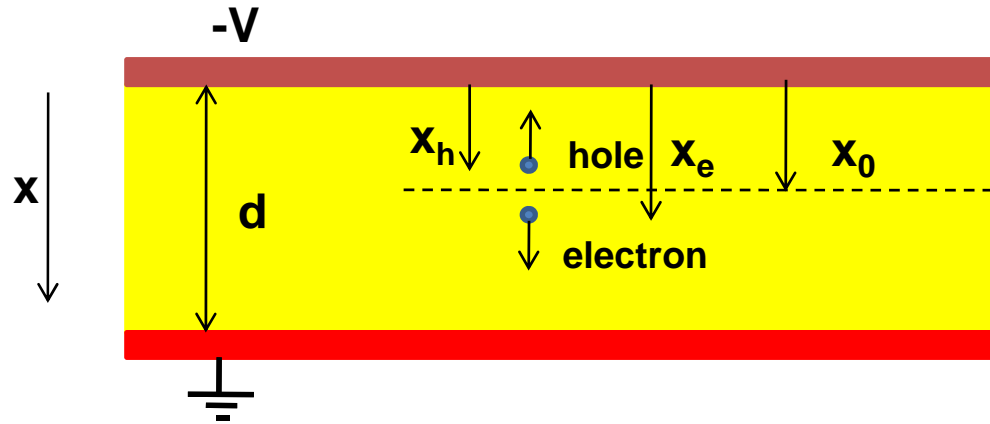

Fig. 5.4. Signal current formation induced by the separation of an electron-hole pair in the electric field of the space-charge region of the detector. The electron-hole pair is created in the center plane of a slightly (20%) overdepleted diode (see Example 5.2). Plotted are the electron-induced (dashed line), hole-induced (dash-dot line) and total (continuous line) currents

Silicon Detector Signals



p+ What is the signal induced on the p+ 'electrode' for a single e/h pair created at $x_0=d/2$ for a 300 μ m Si detector ?

n-

n+

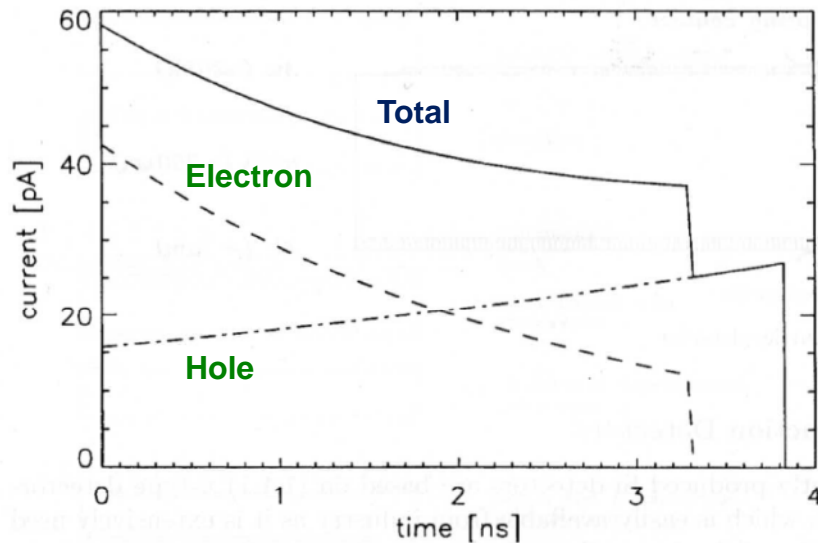

Fig.5.4. Signal current formation induced by the separation of an electron-hole pair in the electric field of the space-charge region of the detector. The electron-hole pair is created in the center plane of a slightly (20%) overdepleted diode (see Example 5.2). Plotted are the electron-induced (dashed line), hole-induced (dash-dot line) and total (continuous line) currents

To calculate the signal from a track one has to sum up all the e/h pair signal for different positions x_0 .

Si Signals are fast $T < 10-15$ ns. In case the amplifier peaking time is $> 20-30$ ns, the induced current signal shape doesn't matter at all.

The entire signal is integrated and the output of the electronics has always the same shape (delta response) with a pulse height proportional to the total deposited charge.

Next Time

More details of signals in Solid State Detectors and Wire Chamber,
Signals in MICROMEAGAs, GEMs, RPCs and Liquid Calorimeters.

MICROMEAGA

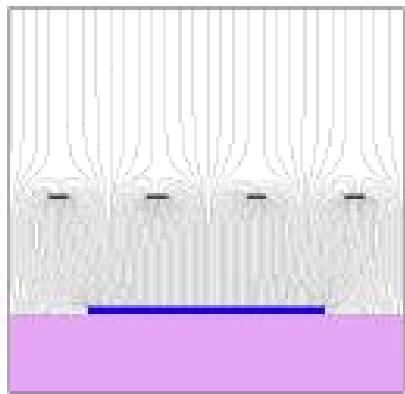

parallel plate

MicroMeshGasdetector

MSGC

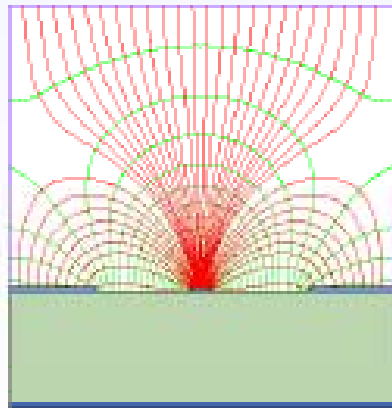

strip

MicroStripGasChamber

GEM

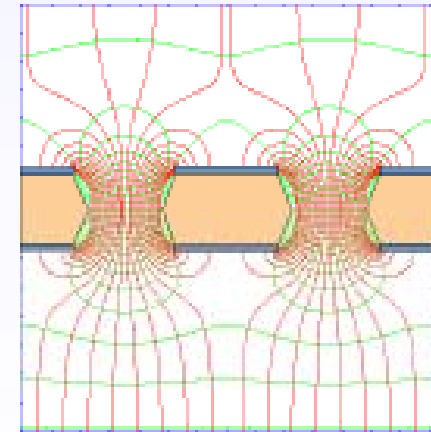

hole

GasElectronMultiplier

Conclusion

This principle of signal generation is identical for Solid State Detectors, Gas Detectors and Liquid Detectors.

The signals are due to charges (currents) induced on metal electrodes by moving charges.

The easiest way to calculate signals induced by moving charges on metal electrodes is the use of Weighting fields (Ramo – Schottky theorem) for calculation of currents induced on grounded electrodes.

These currents can then be placed as ideal current sources on an equivalent circuit diagram representing the detector.