

Measurement of Photons and Neutral Pions in the Very Forward Region of LHC

O. Adriani(1), L. Bonechi(1), M. Bongi(1), R. D'Alessandro(1), D.A. Faus(2), M. Haguenuer(3), Y. Itow (4), K. Kasahara(5), K. Masuda(4), Y. Matsubara(4), H. Menjo(4), Y. Muraki(4), P. Papini(1), T. Sako(4), T. Tamura(6), S. Torii(7), A. Tricomi(8), W.C. Turner(9), J. Velasco(2) , K. Yoshida(6)

(The LHCf collaboration)

- (1) INFN Firenze, Univ. di Firenze, Firenze, Italy
- (2) IFIC, Centro Mixto CSIC-UVEG, Valencia, Spain
- (3) Ecole-Polytechnique, Paris, France
- (4) STE laboratory, Nagoya University, Nagoya, Japan
- (5) Shibaura Institute of Technology, Saitama, Japan
- (6) Kanagawa University, Yokohama, Japan
- (7) RISE, Waseda Univ., Tokyo, Japan
- (8) INFN Catania, Univ. di Catania, Catania, Italy
- (9) LBNL, Berkeley, California, USA

1. Review of experimental purpose

2. The results of the test experiment

3. Trigger, Beam condition, Schedule, Concluding remarks

12 May 2004

Measurement of Photons and Neutral Pions in the Very Forward Region of LHC

1. Scientific purpose

The main purpose is to establish proton-proton interactions at the highest energy region with use of the highest energy accelerator in the world.

It has been a long dream for cosmic ray physicists.

2. Experimental proposal

The proposal describes that a small calorimeter will be installed in front of the collision point at 140m away. **It would be the smallest experiment using the largest accelerator in the world.**

3. The beam condition

We require rather low luminosity operation, say 10 bunches(43) in the ring with 1×10^{10} protons in a bunch. **The machine people will enjoy a very special run of the accelerator for only a few hours.**

4. Summary

We will be able to establish very important data point by this experiment, which will be very useful for not only cosmic ray people but also the GEANT 4 people.

Cosmic Ray Flux

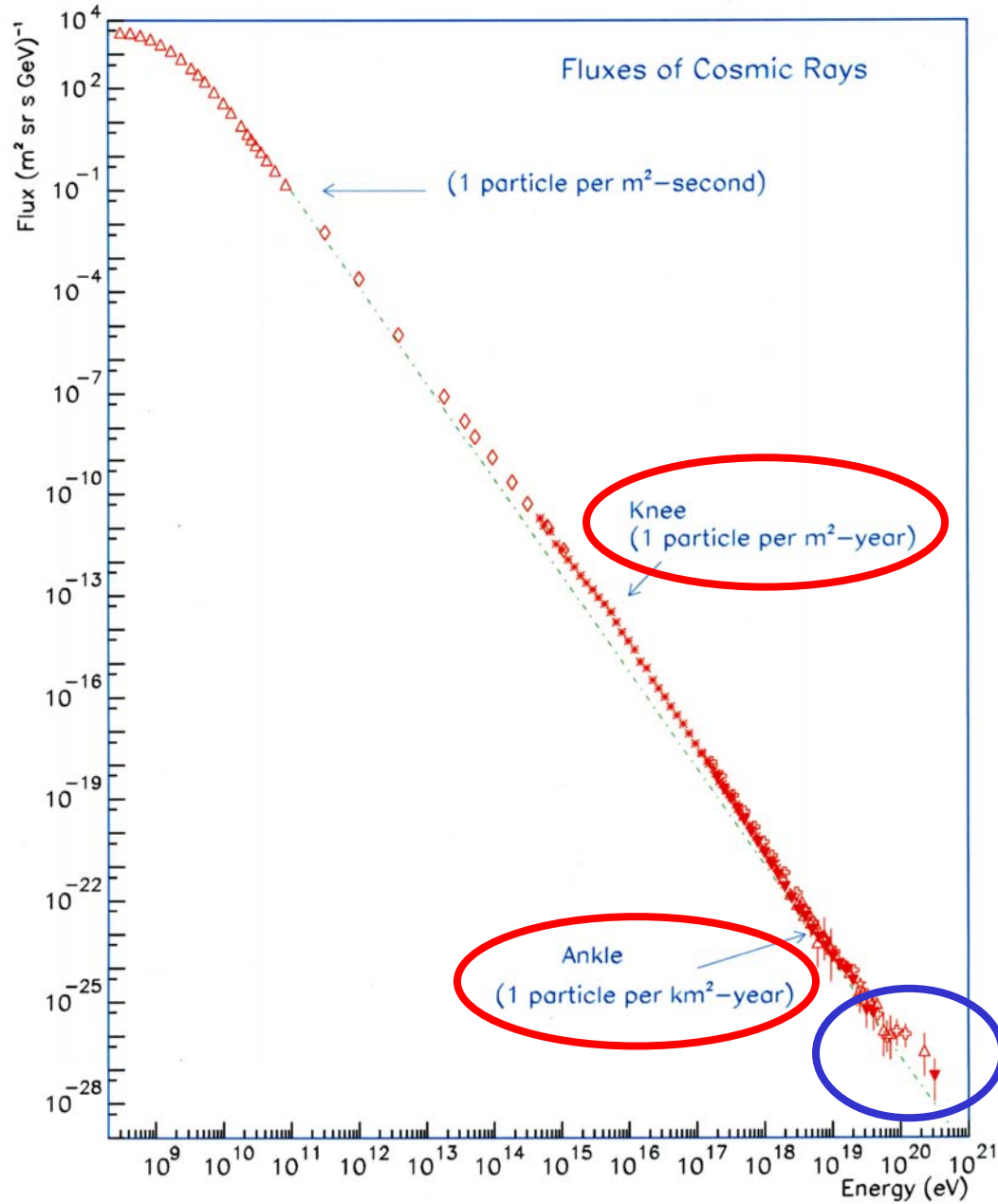

10^9 eV

10^{20} eV

Energy spectrum of Cosmic Rays

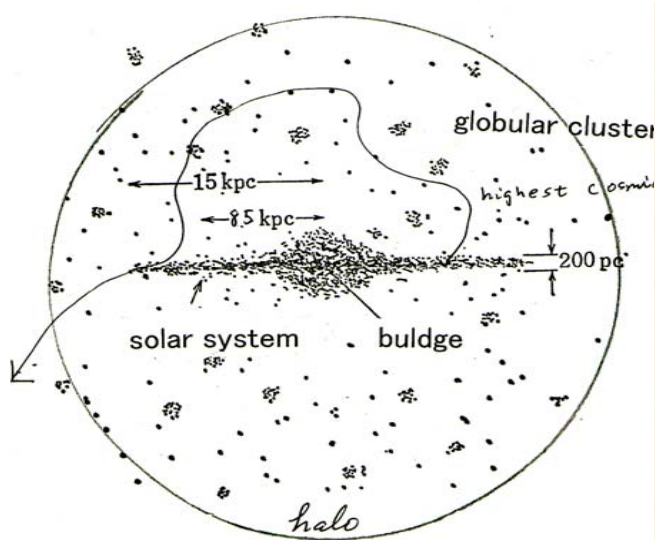
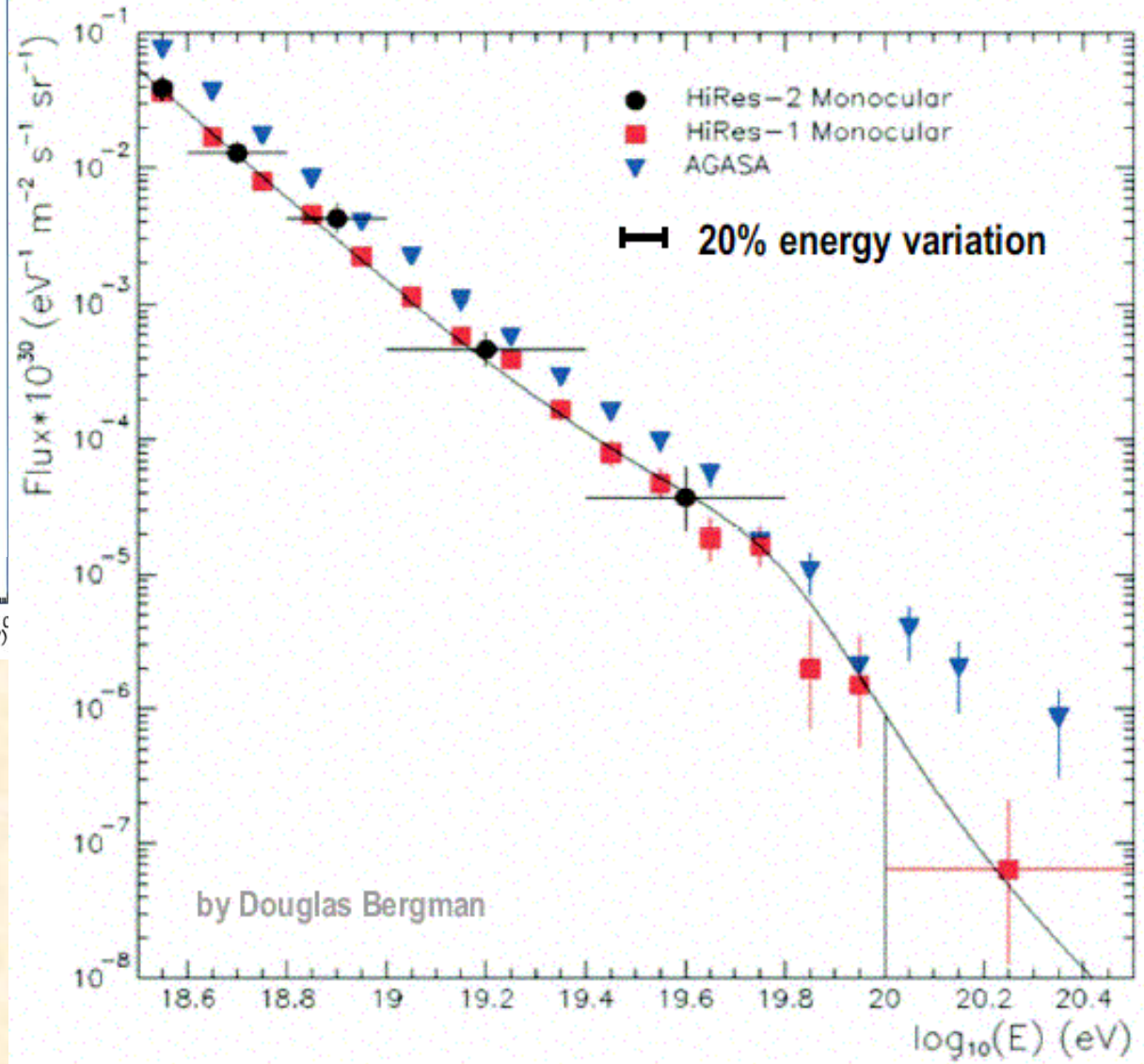
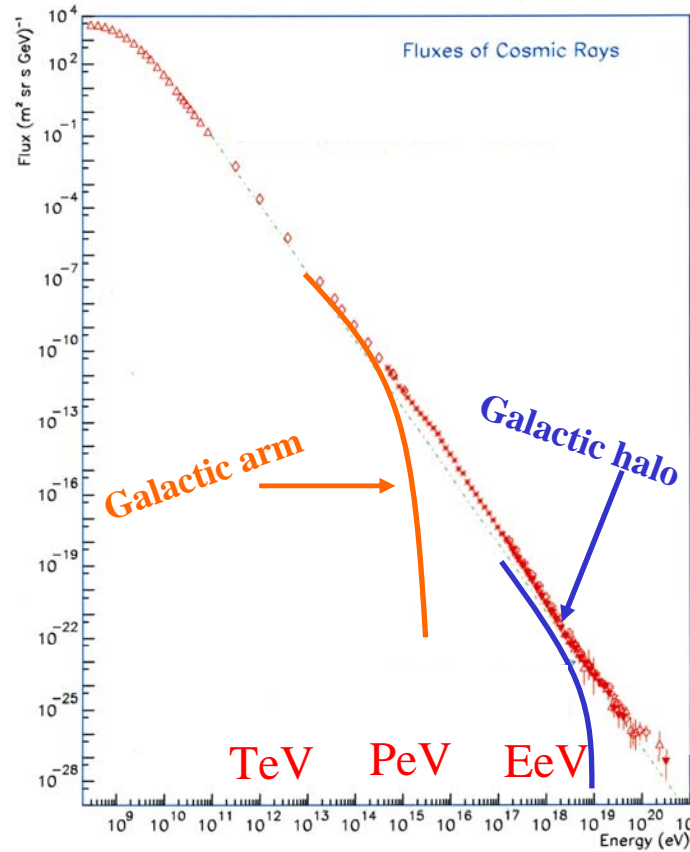

New AUGER and Stereo Hi Res data (preliminary)

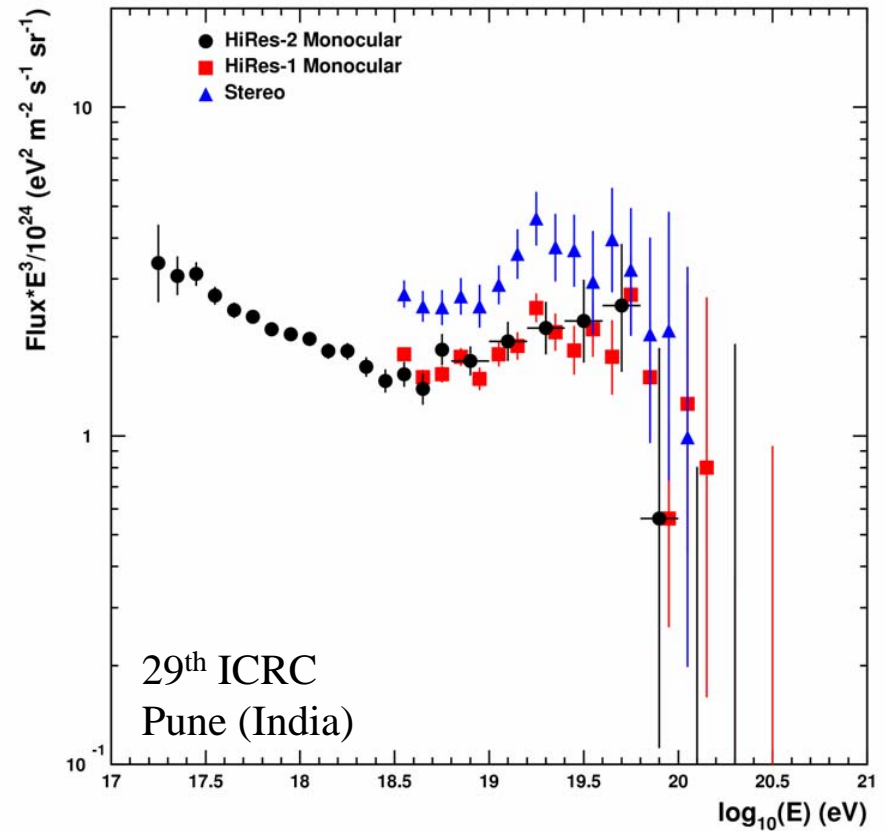
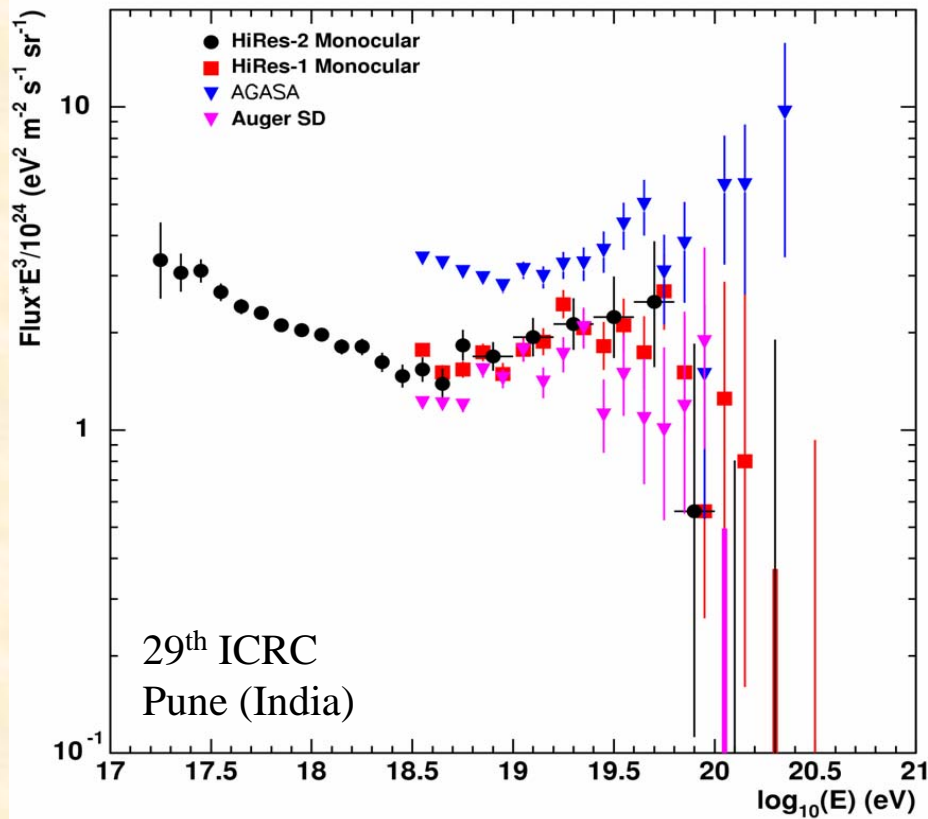

inclusive cross-section

Pion x-distribution at 10^{17} eV pp interaction
 $\frac{1}{\sigma_{in}} x \frac{d\sigma}{dx}$
 production cross-section
 Artificial two examples

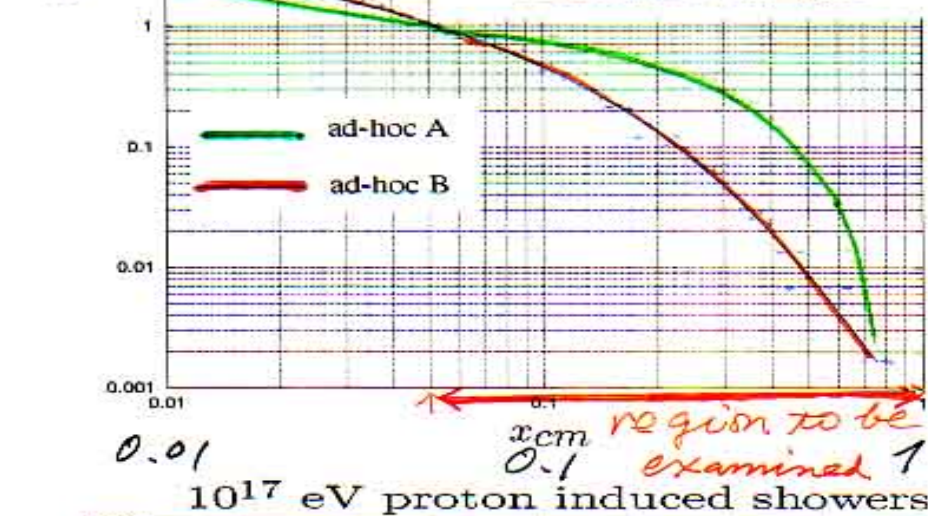

A ~ DPMJET/QGSJET

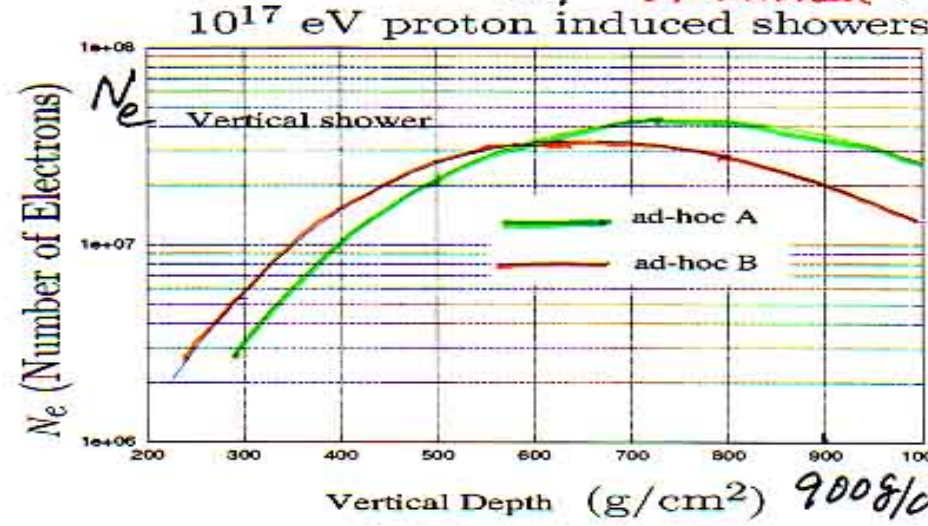

shower development

Fig. 9 Two different type production models of secondary particles are presented as a function of the Feynman variable X at the center of mass (top) and shower curves expected from the production type A and B for $E_0=1 \times 10^{17}$ eV. At 900 g/cm², the number of particles differs about 1.75 times.

5×10^{19} eV proton initiated showers

Zenith angle 60 deg.

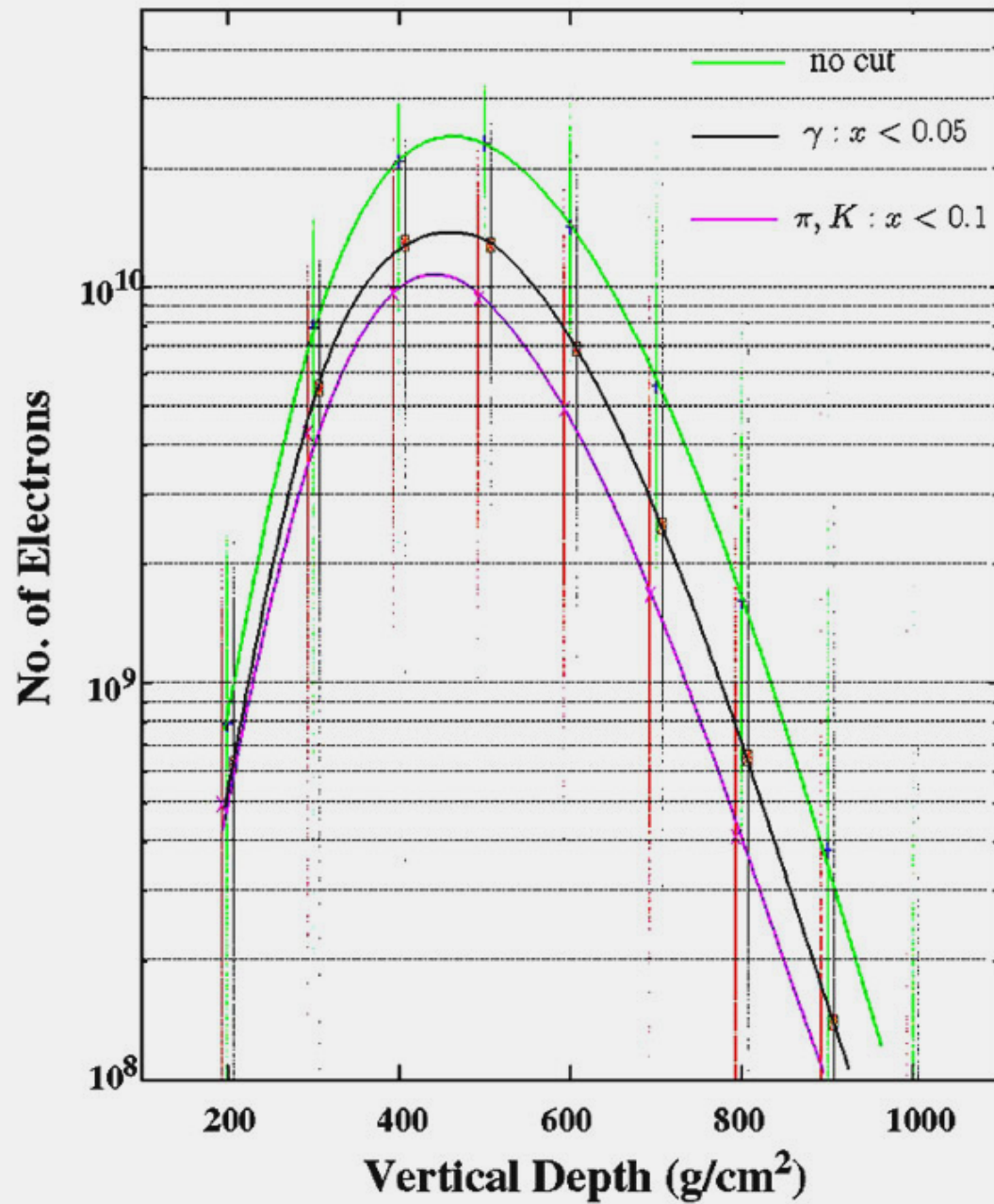

The position of shower maximum

Knapp et al, Astroparticle Physics, 19(2003) 77

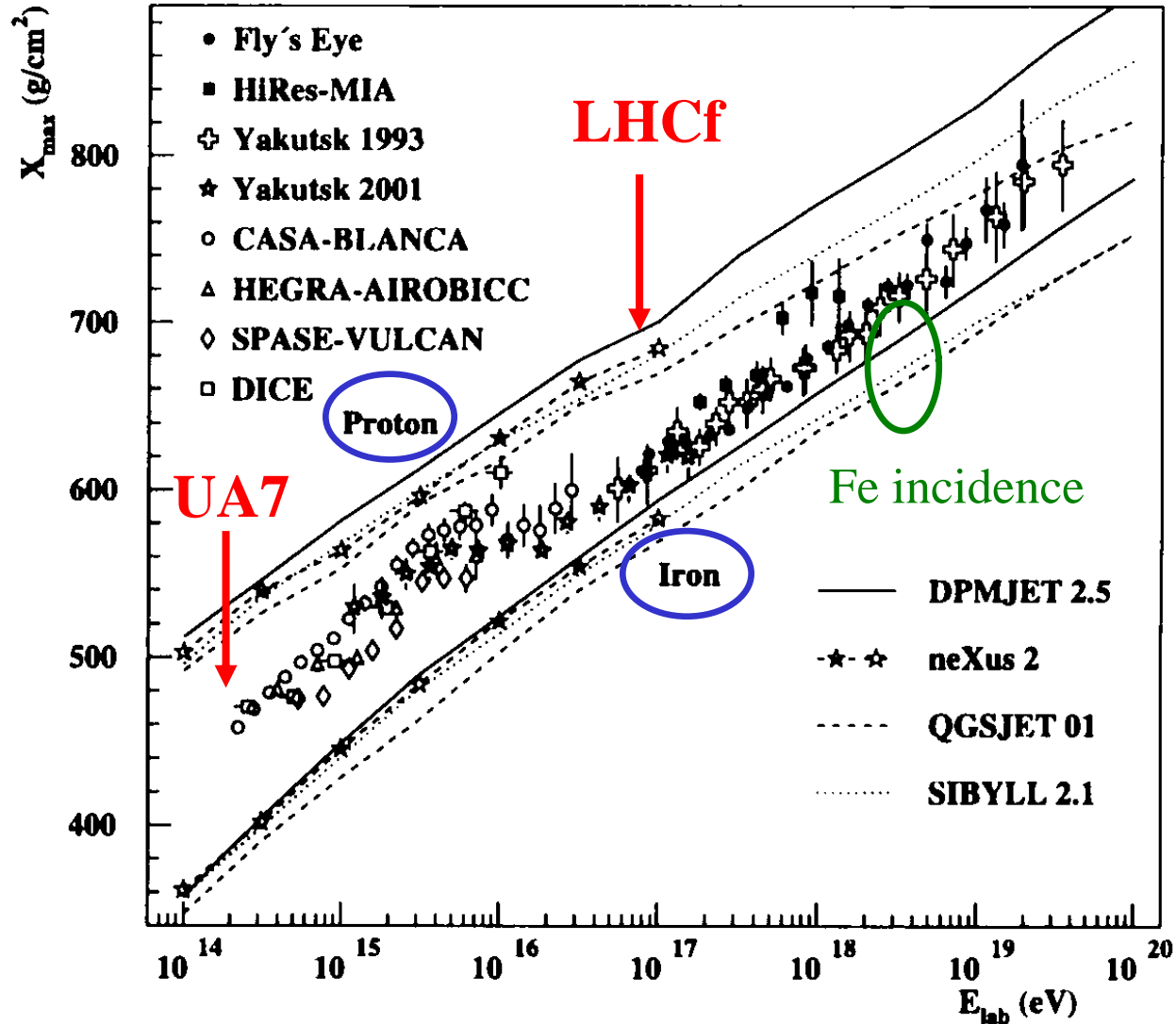

Additional statement on the L.O.I.

Within a year (2004-2005), two new data have been presented in the 29th ICRC by the AUGER and Hi-Res groups, but the riddle on the highest energy cosmic rays has been left. It has been cleared that the forthcoming results by the LHCf experiment will become more and more important.



TAN VACUUM DESIGN -3D OVERVIEW

Y Chamber

THE VACUUM TUBE CONTAINS TWO COUNTER-ROTATING BEAMS. THE BEAMS TRANSITION FROM ONE BEAM IN EACH TUBE TO TWO BEAM IN THE SAME TUBE.

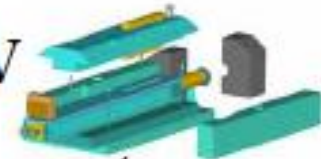

Detector location



THE TWO COUNTER-ROTATING BEAMS INTERSECT 140 METERS

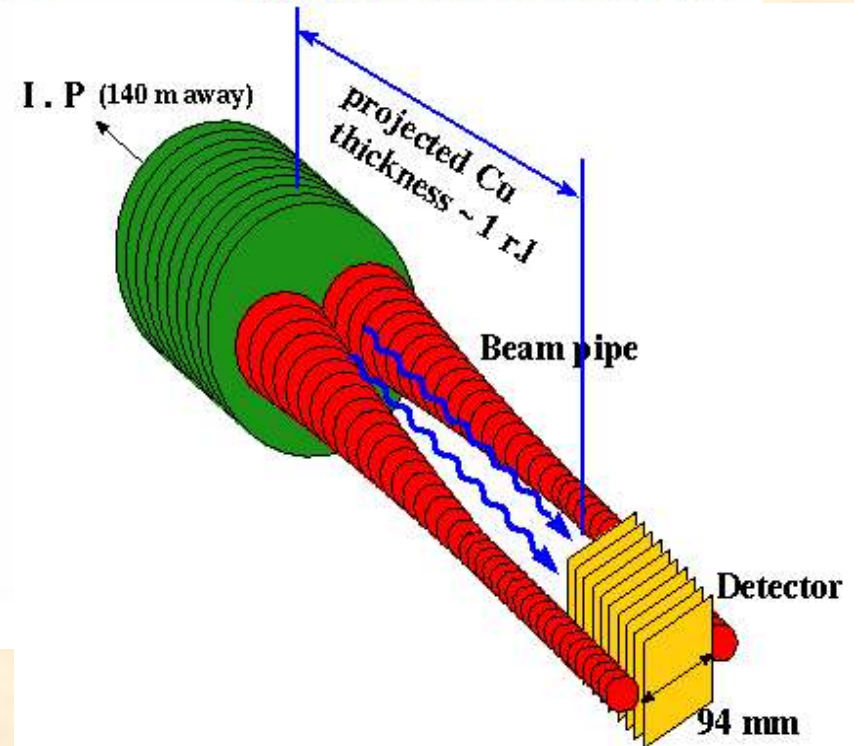

TAN Nomenclature

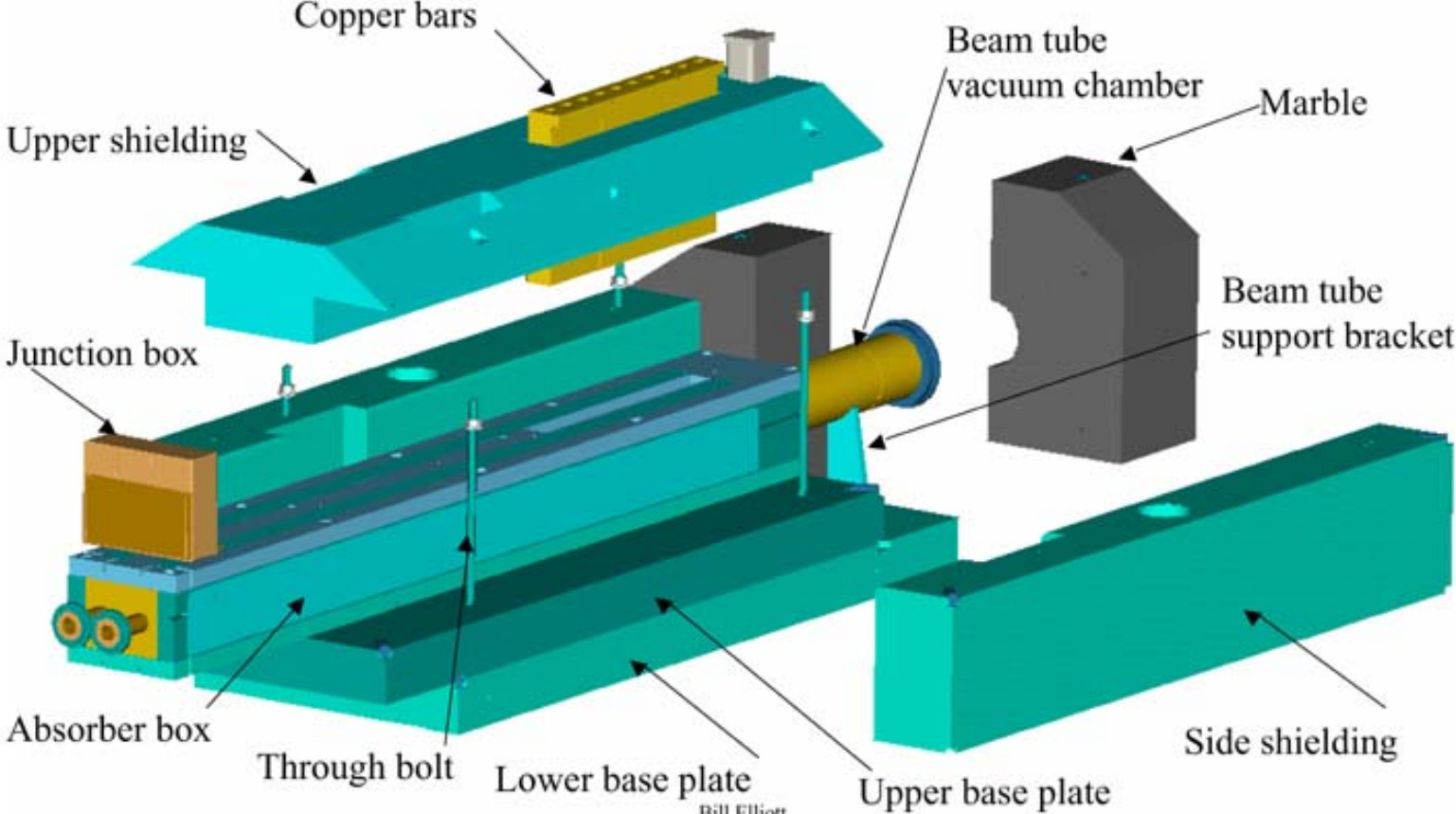

Bill Elliott
TAN/TAS ASSEMBLY

The TAN for the luminosity monitor

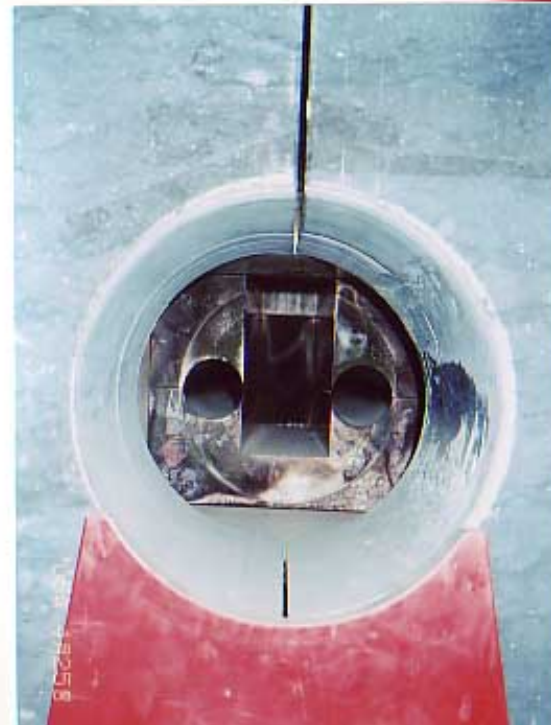

Photos taken
On April 25th, 2005
At CERN

Detector #1: transverse projection

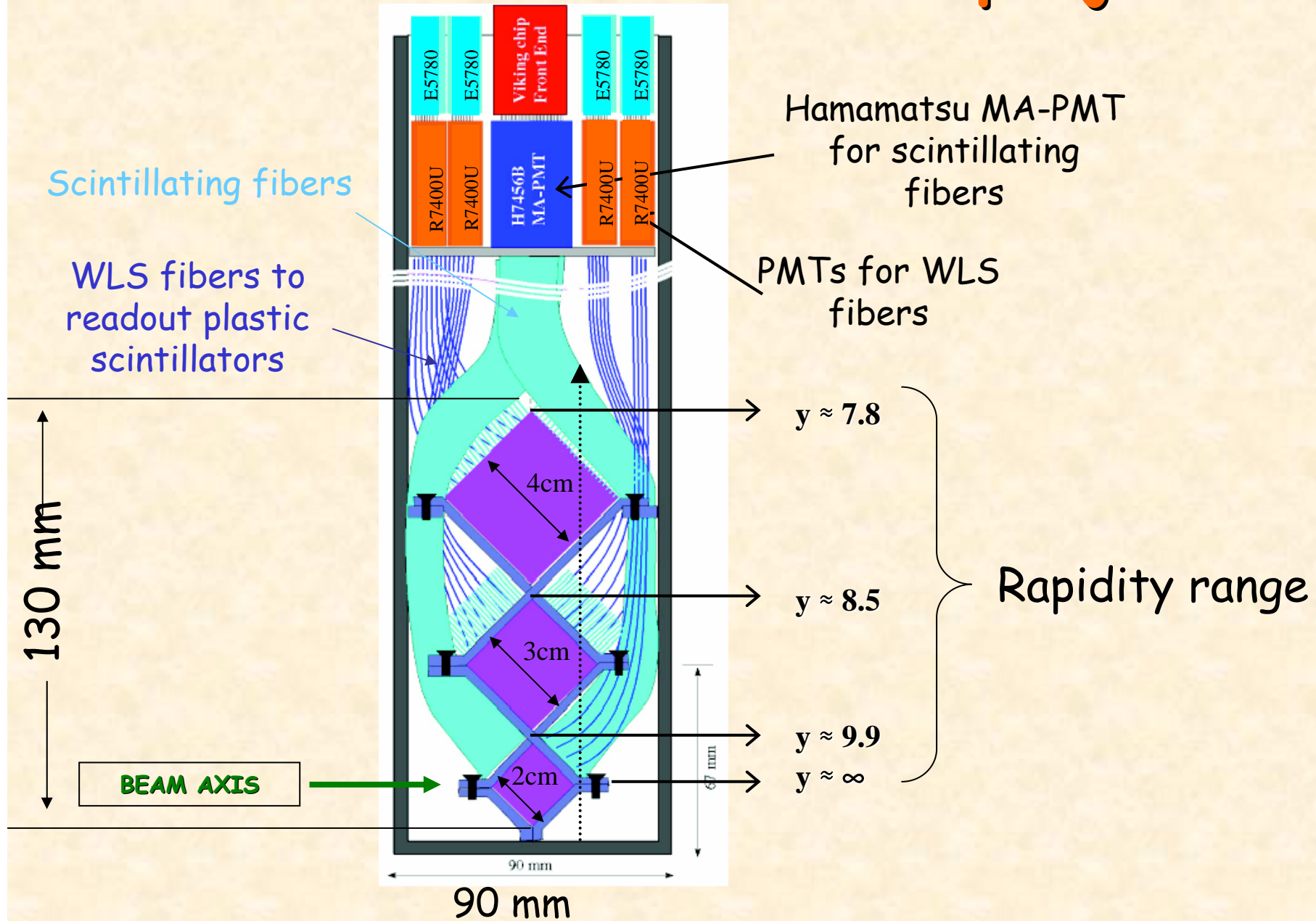

Energy resolution

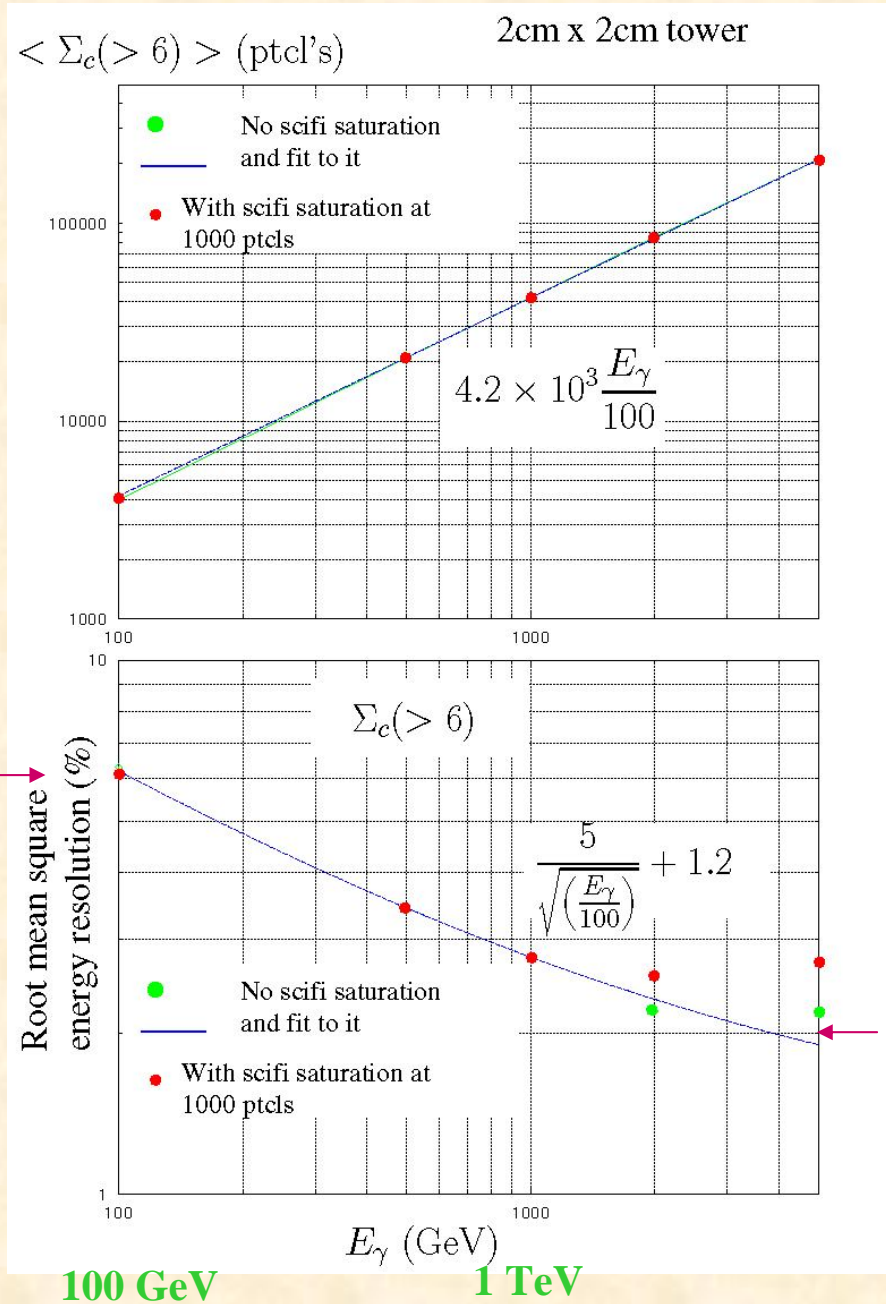

6 %

2 %

Cross-section derivation

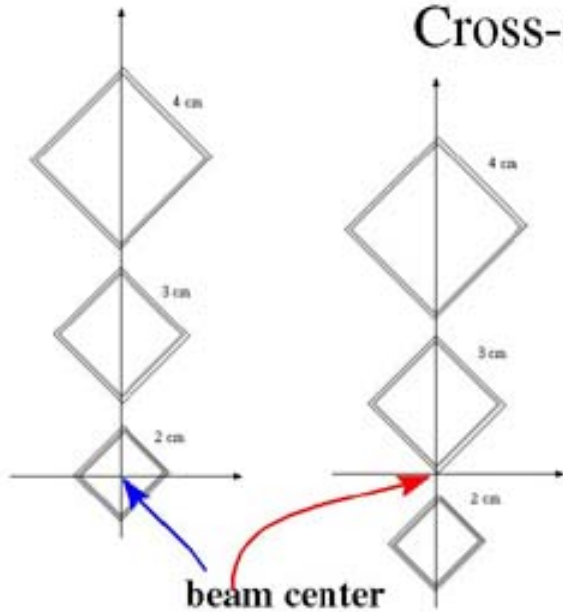

By standard config.

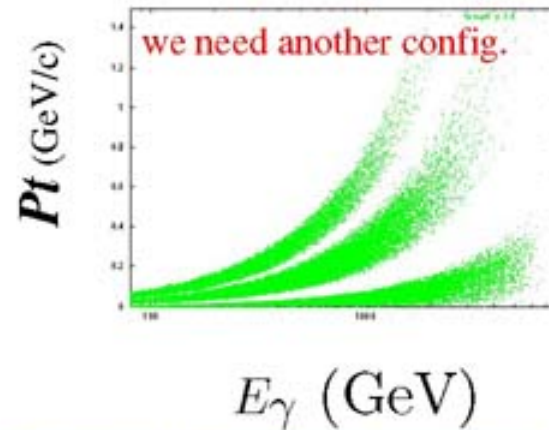

Acceptance corrected

With two config., we can reconstruct cross-section of standard model (lines : dpmjet3) by observing 10^6 events (dots)

Geometrical acceptance

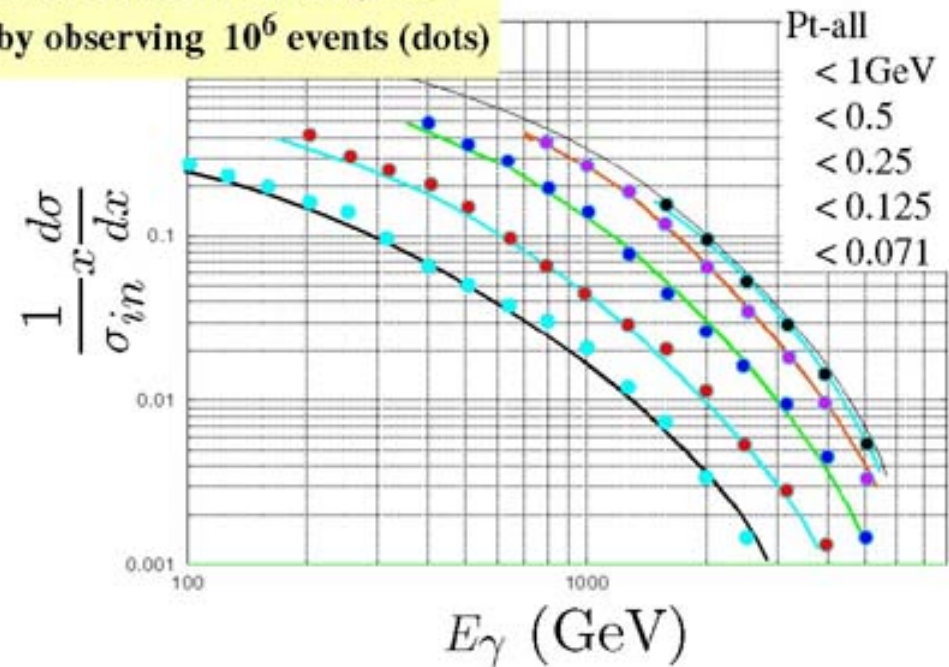
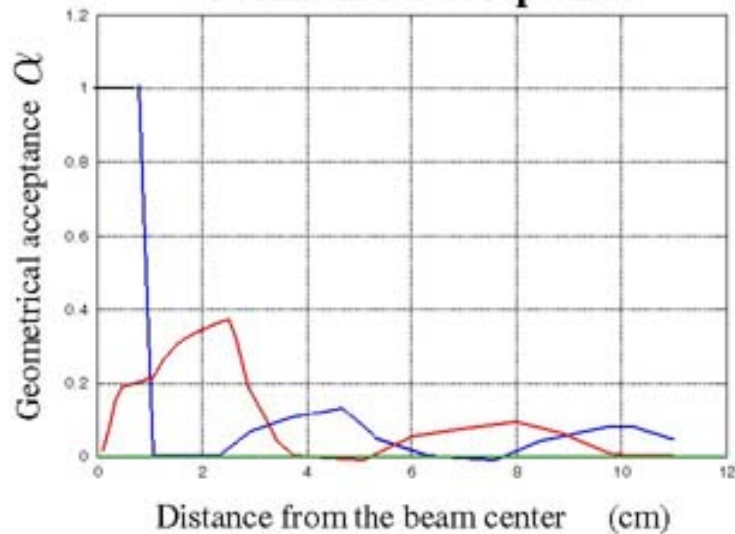

What we have done in a year

1. Monte Carlo calculations using **DPMJET3, QGSJET and SYBILL** models (popular in cosmic rays).
2. We have made the same detector that we have proposed and made an exposure at the CERN NA H4 beam line.
→ e , μ , p to measure $\Delta E/E$ and **edge effect**
3. We have investigated the calibration of the absolute value of shower particles in a range from **1000 – 100,000** by using a nitrogen laser system.

We would like to report mainly those results today.

Monte Carlo γ ray energy spectrum

10^6 generated LHC interactions \rightarrow 1 minute exposure

Gamma Energy Spectrum of 20mm square at Beam Center

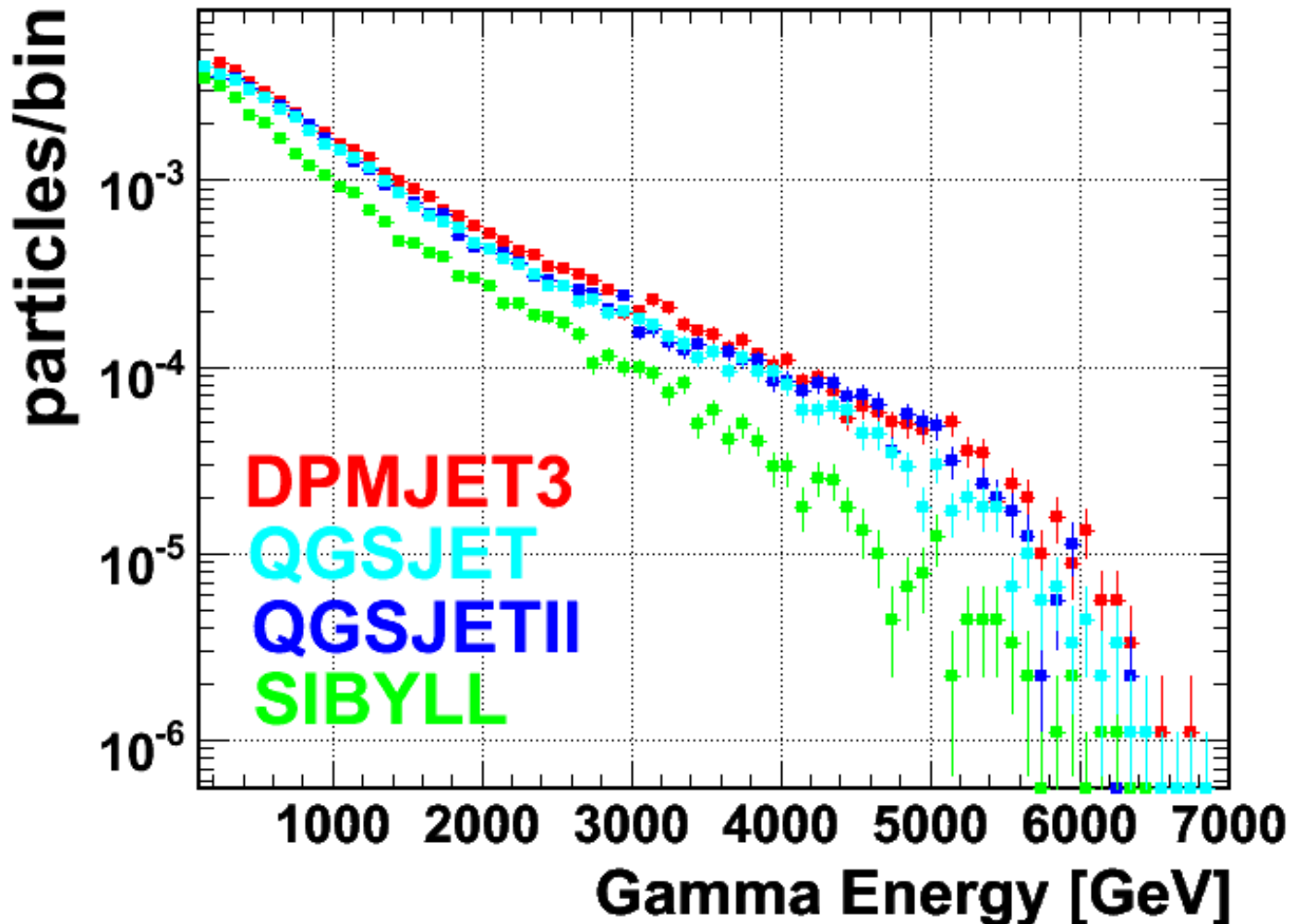

γ ray energy spectrum for different positions

Gamma Energy Spectrum
of 20mm calorimeter at Center

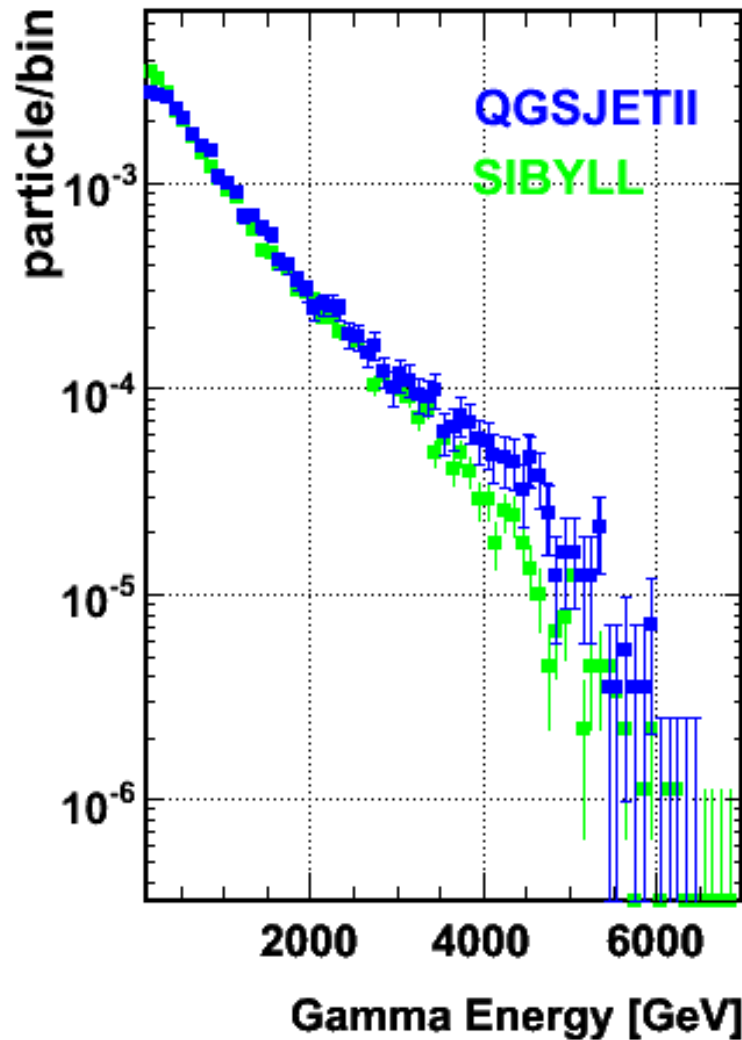

Gamma Energy Spectrum
of 20mm calorimeter at 30mm shift

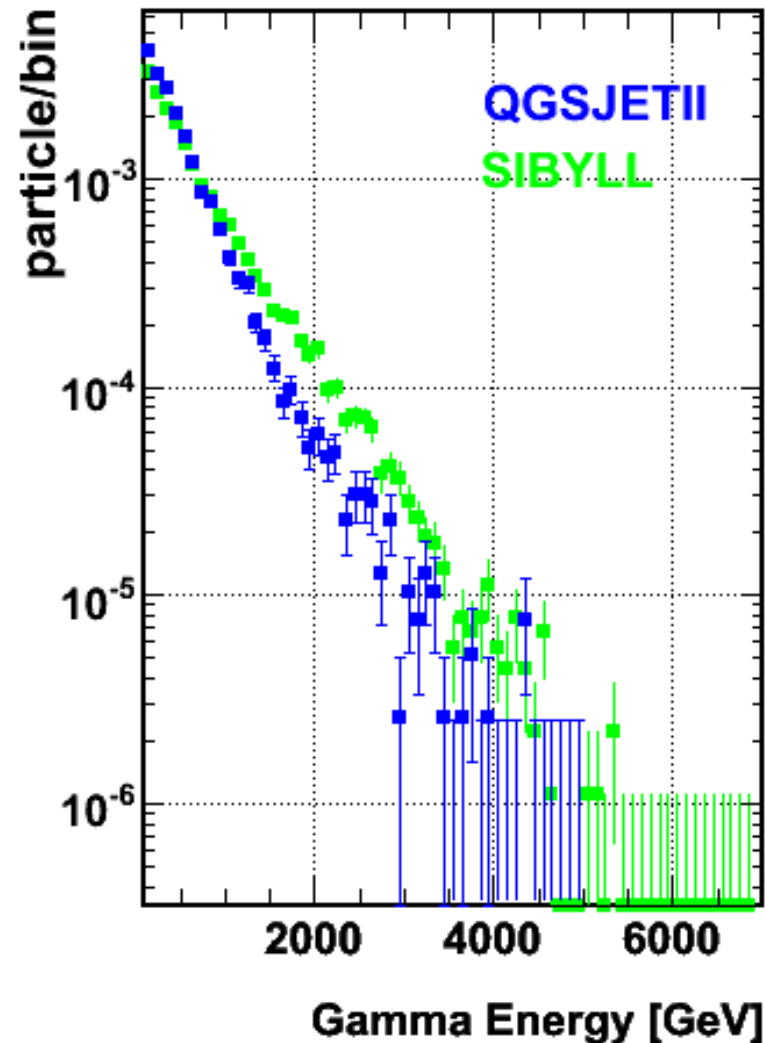

Examples of simulated events for γ and n

400 GeV photon

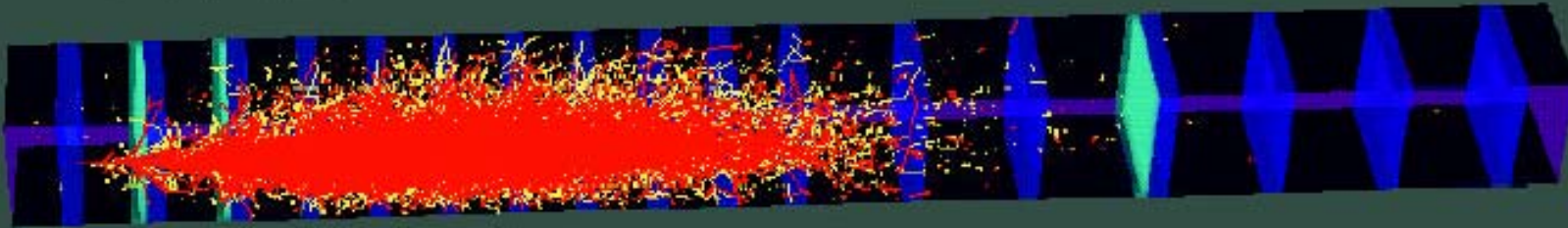

1.2 TeV neutron

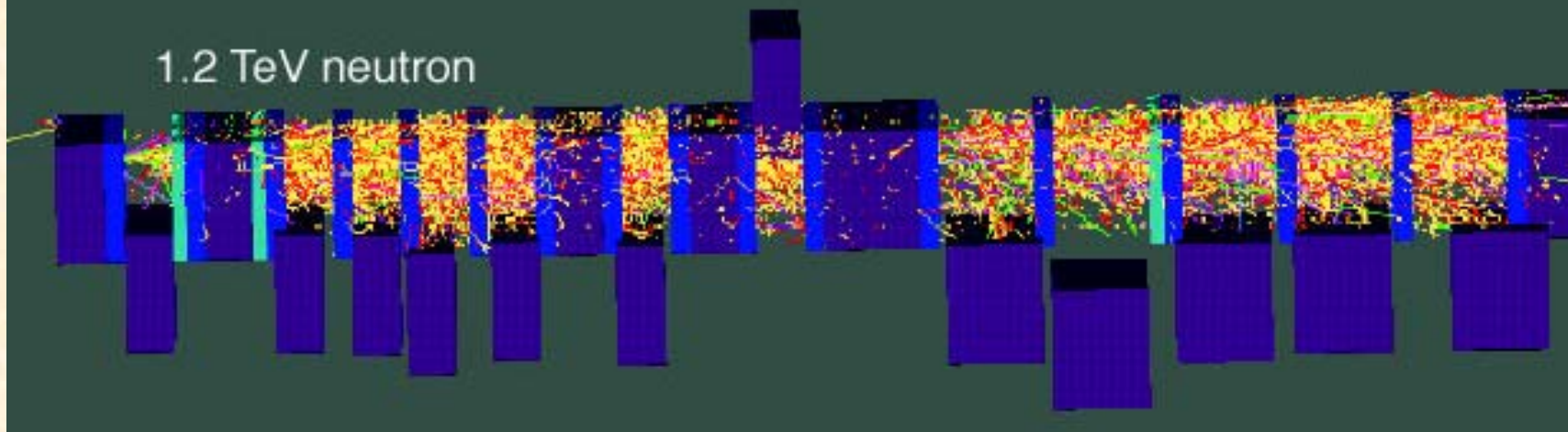

Additional statement on the L.O.I.

Within a year, two new data have been presented at the 29th ICRC by the AUGER and Hi - Res groups, but still the riddle on the highest energy cosmic rays has been left and furthermore the forthcoming results from the LHCf experiment has been important.

Summary 1 (on physics)

The particle production cross-section in the very forward region that will be obtained by the LHCf experiment will be very useful for various Monte Carlo generators.

The calorimeter in the test experiment



Size: 9.6 cm x 29 cm x 55 cm

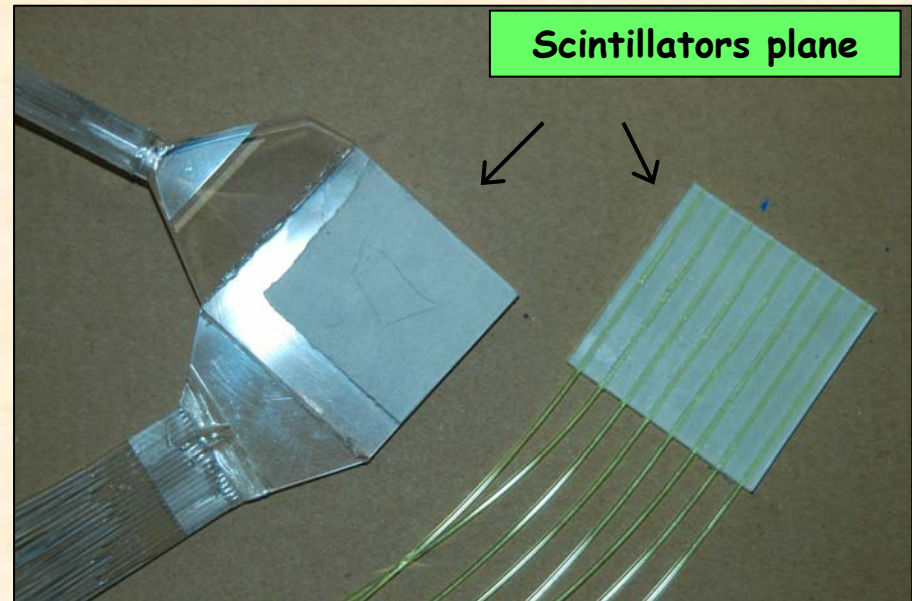
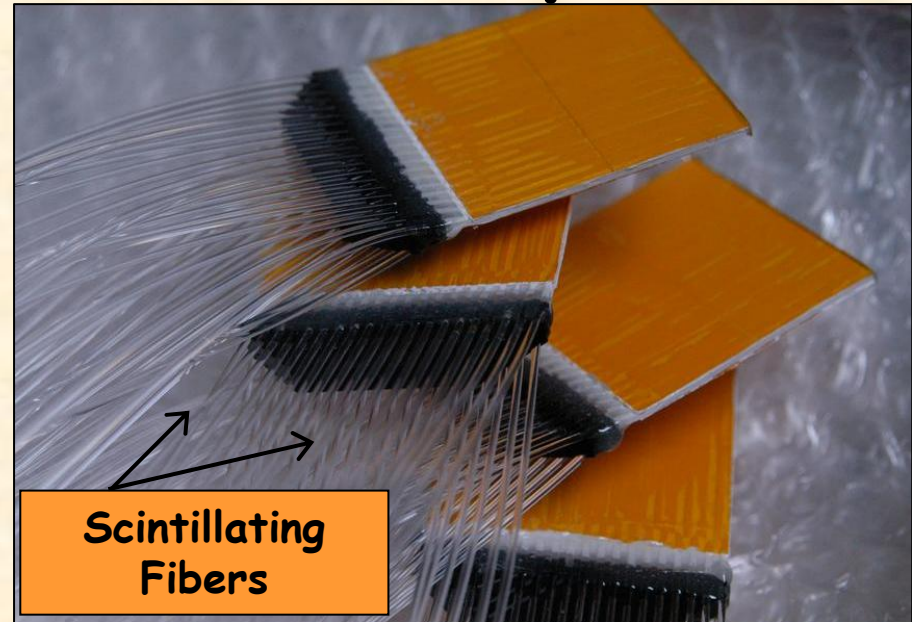

The CERN test experiment on August 2004 (H4 Beam Line)

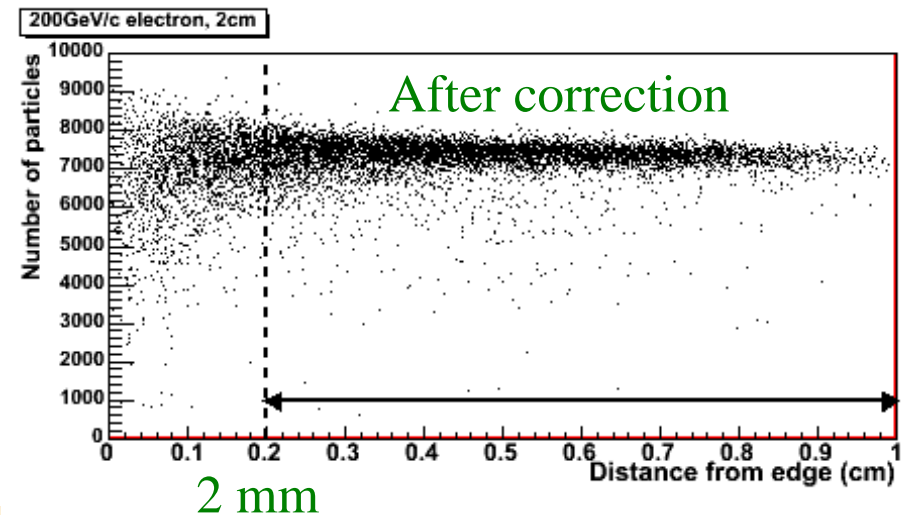
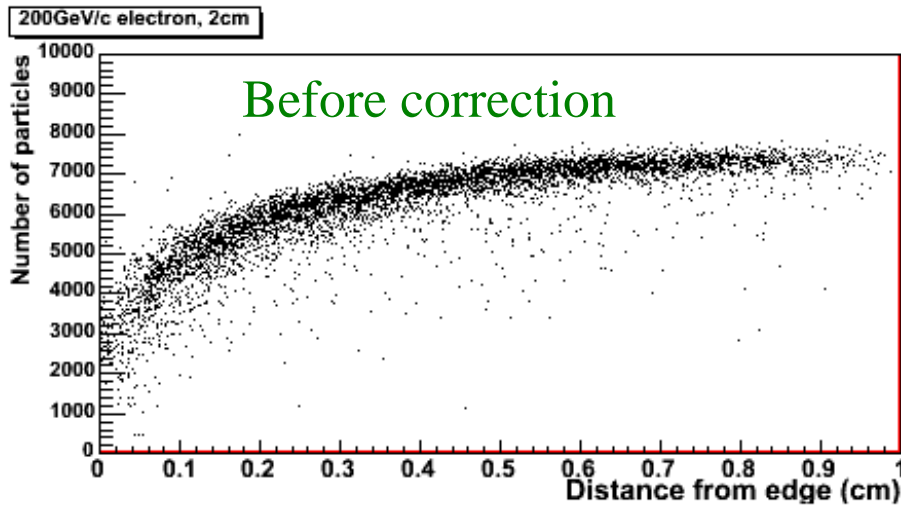
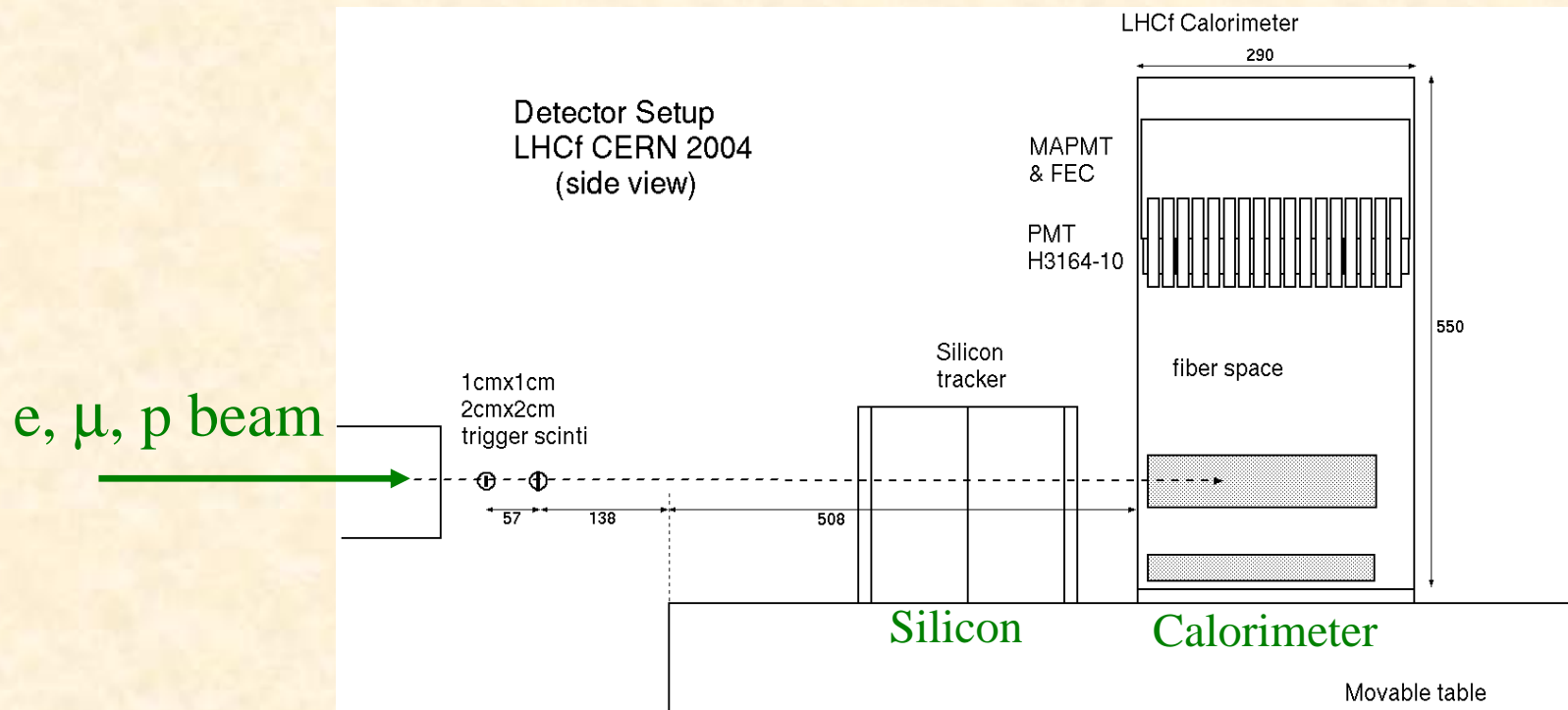

Energy resolution

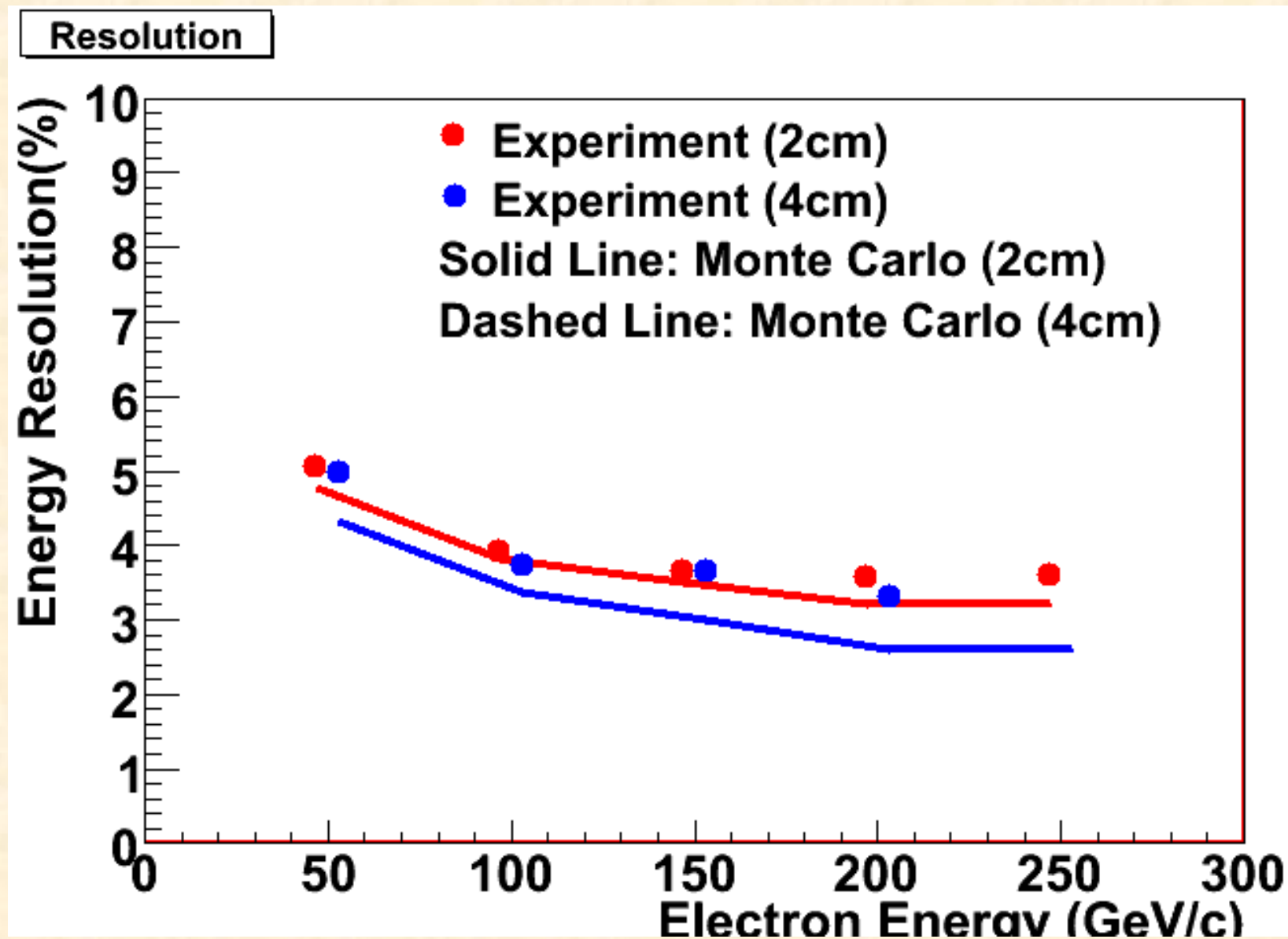

We successfully developed high dynamic range photomultiplier system (R7400U modified)

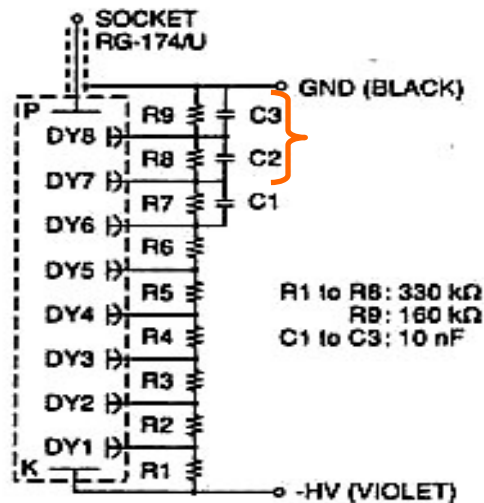

	Normal Assembly	Modified Assembly
R9	1K C	3K C
R8	2K C	3K C
R7	2K C	2K C
R6	2K	1.3K C
R5	2K	1K
R4	2K	1K
R3	2K	1K
R2	2K	2K
R1	2K	2K
	K=160k Ω C=10nF	K=150k Ω C=10nF

Before Modification
GAIN: 5000 HV: -400 V

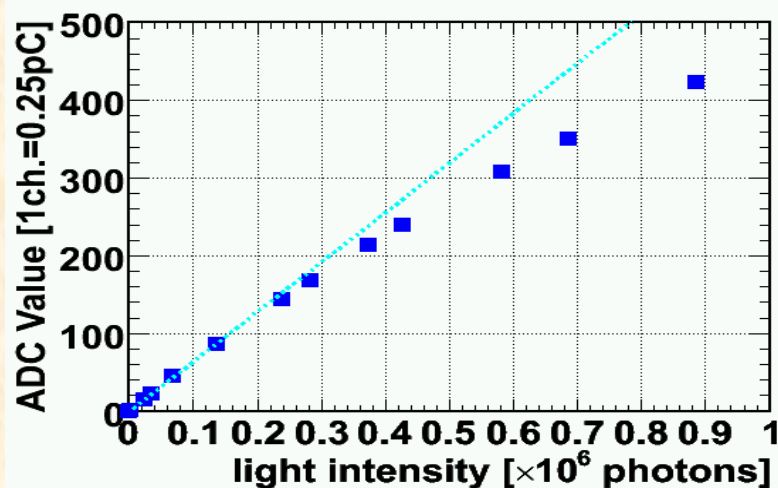

After Modification
GAIN: 260 HV: -450V

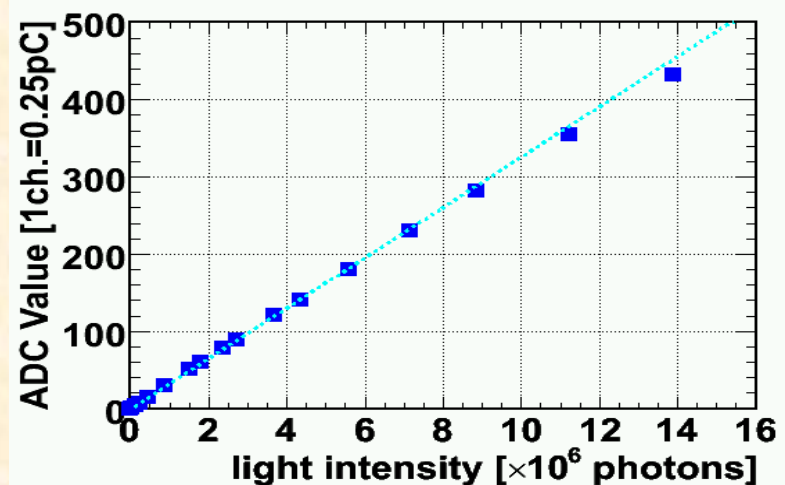

HV – GAIN at R7400U Modified

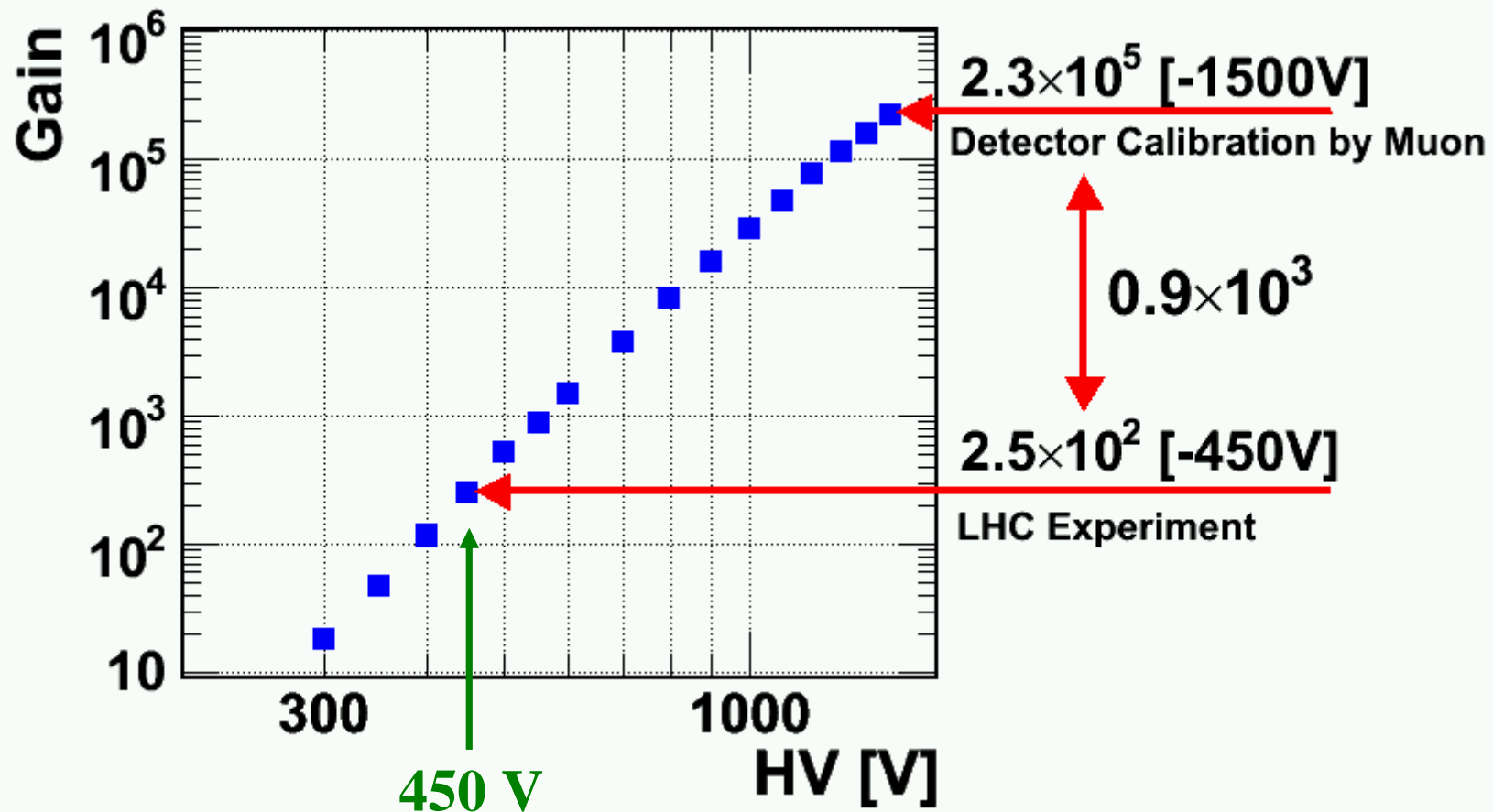

Multiple events/energy contamination

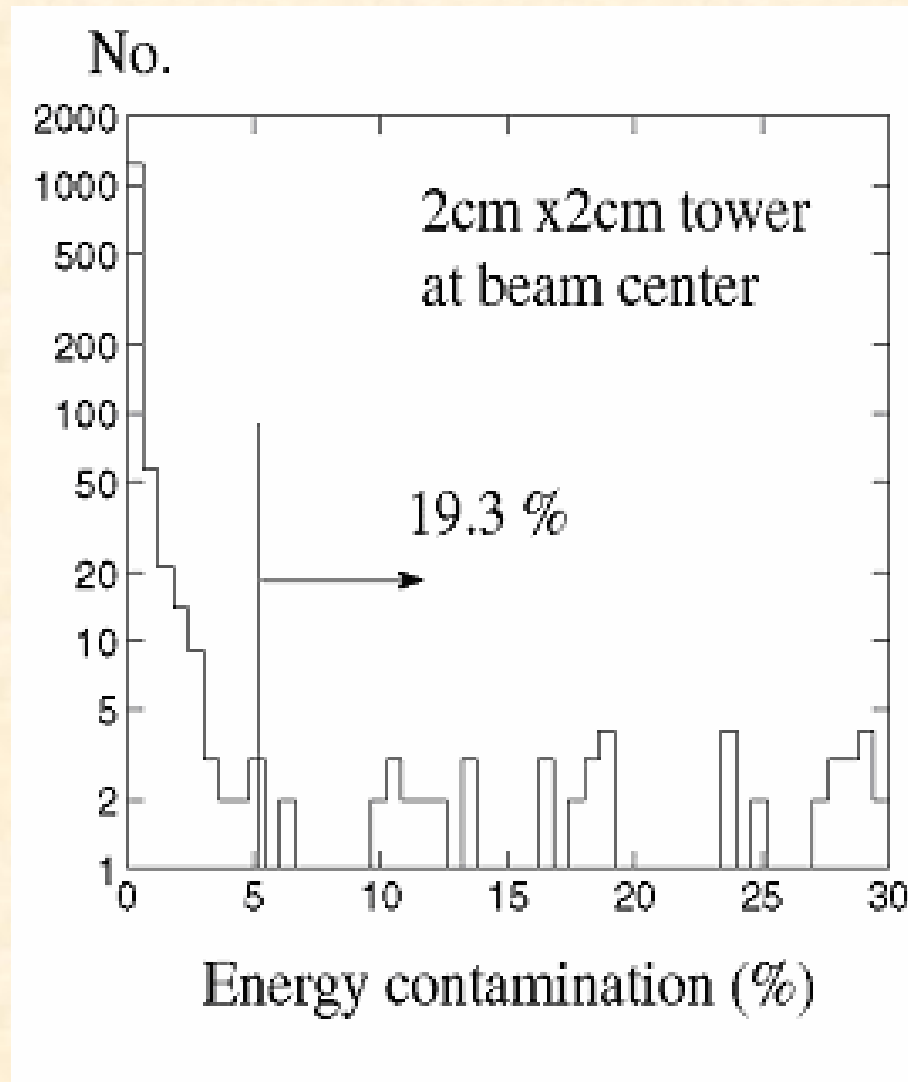

Tower 3 x3 + 2x2 + 4x4

π^0 Invariant mass distribution

of events

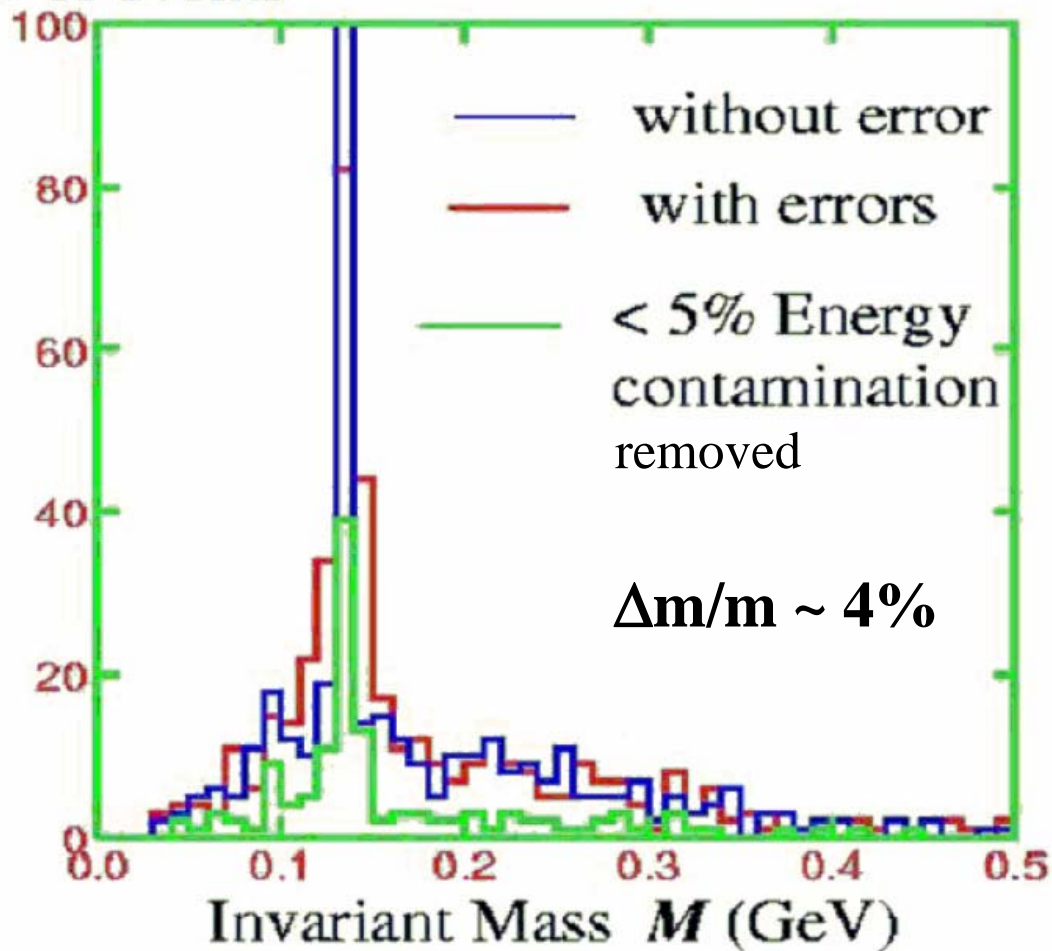

10^6 LHC interactions
 ~ 1 minute exposure

Summary 2

By the actual experiments, we have demonstrated that the experiment proposed in the L.O.I. and Technical Report of the LHCf experiment **CAN measure the production cross-section of photons with $X_F \geq 0.1$ with an accuracy of $\Delta E/E \sim 4\%$. The mass of neutral pions will be obtained with an accuracy about $\Delta m/m \sim 4\%$.**

Hopefully we will be able to get the absolute value of the mass of neutral pions without any systematic adjustment of the energy scale of shower particles.

Geometrical acceptance

γ

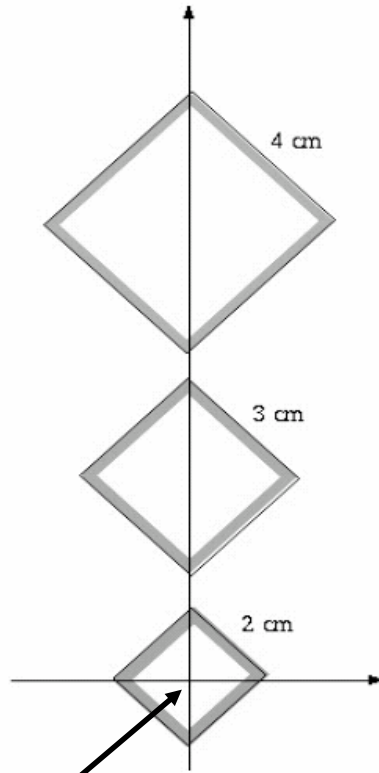
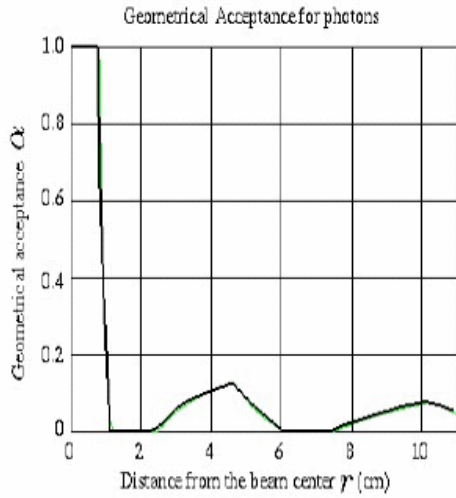

The axis of the beam pipe

2 γ from π^0 : 1% \rightarrow

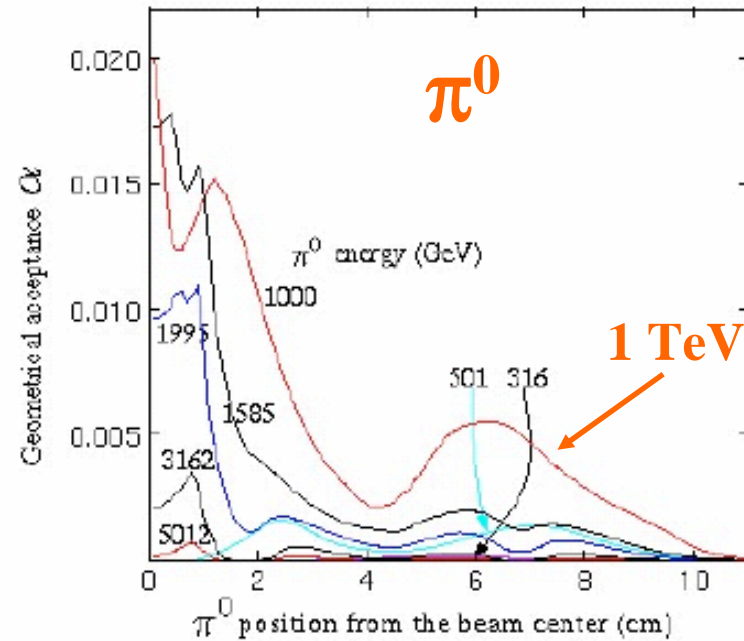

2 independent detectors on both sides of IPX

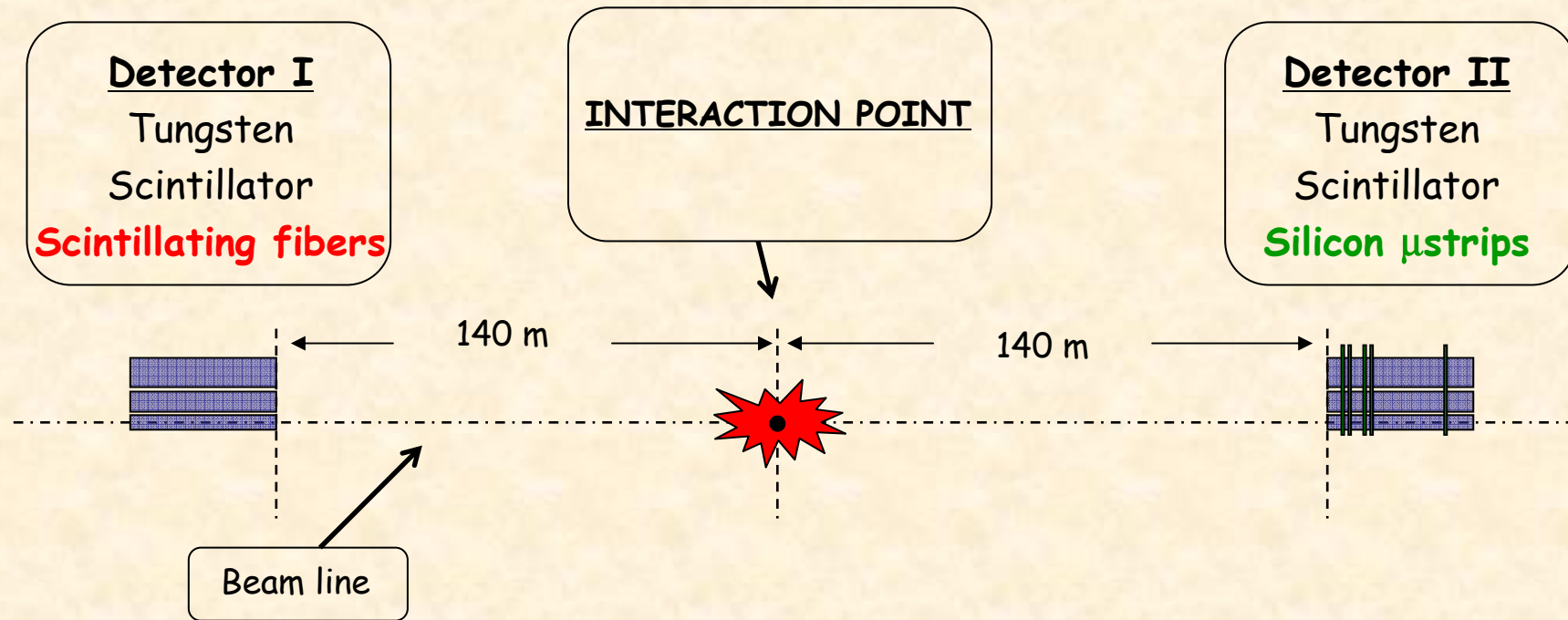

1. Redundancy
2. Background rejection (especially beam-gas)
3. Physics single diffractive/double diffractive

Detector #2

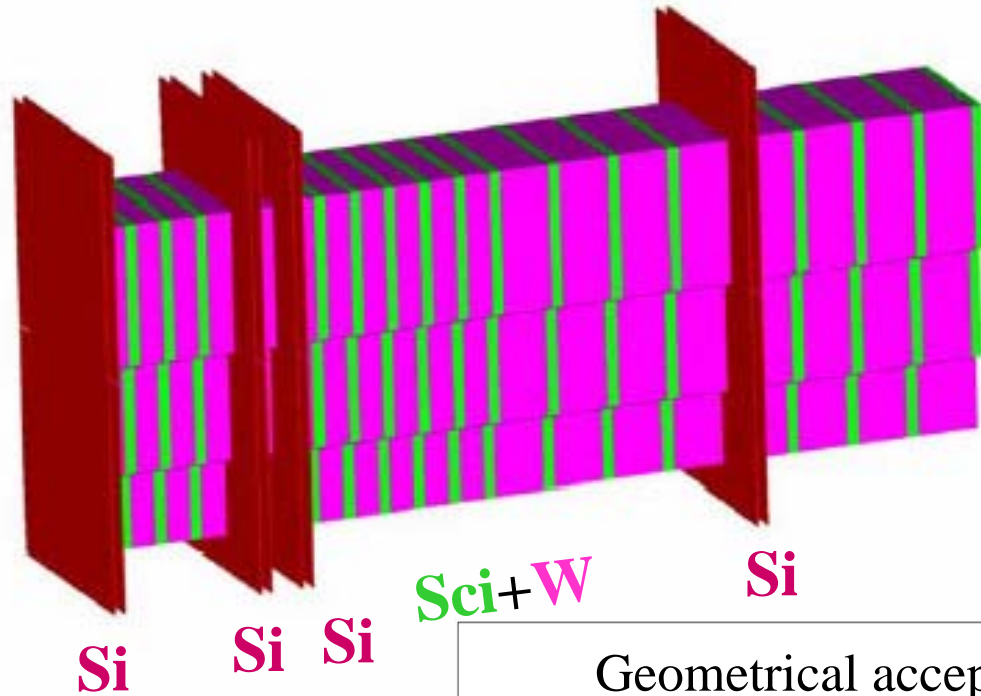
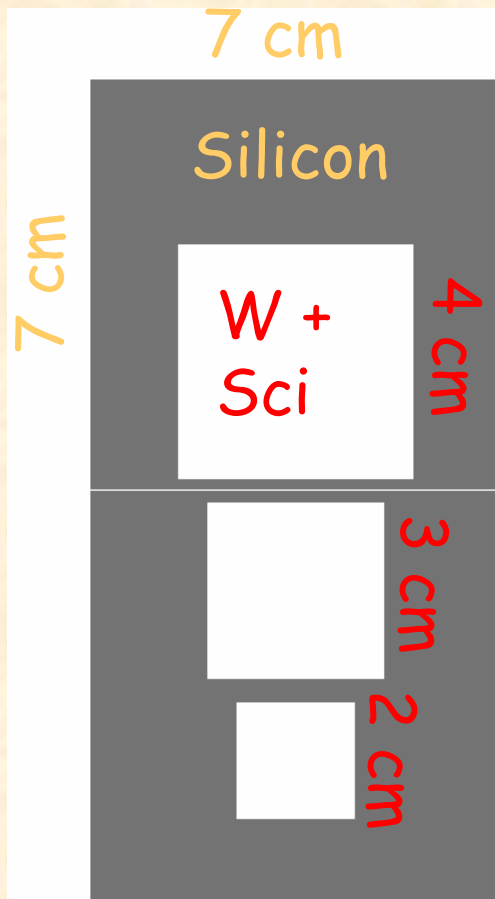

SciFi are replaced by silicon μ strips
70x70 mm²
Pitch 80 μ m
3 double layers (x-y)
1 double layer in front of the calorimeter

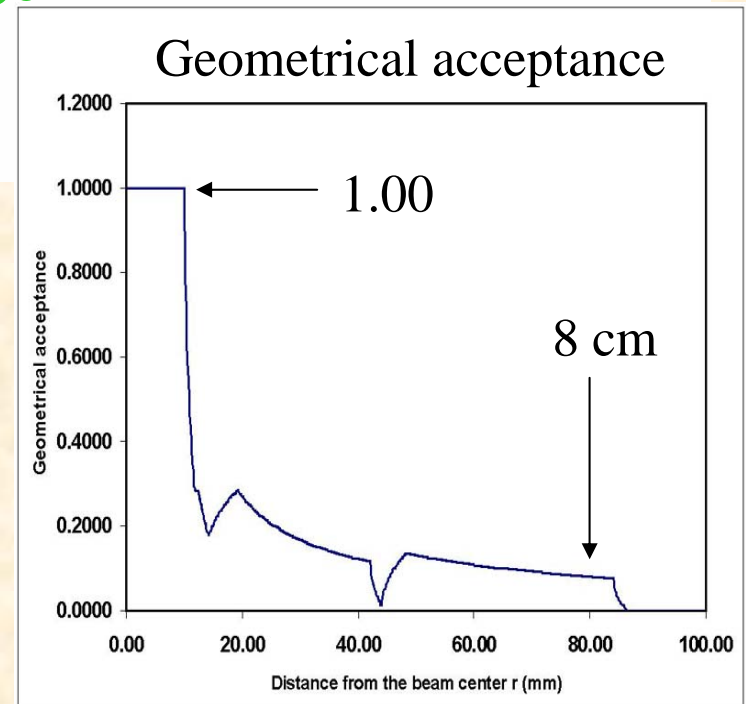

EUROPEAN ORGANIZATION FOR NUCLEAR RESEARCH
European Laboratory for Particle Physics



Large Hadron Collider Project

LHC Project Report 674

**RESIDUAL GAS DENSITY ESTIMATIONS
IN THE LHC EXPERIMENTAL INTERACTION REGIONS**

A. Rossi and N. Hilleret

Abstract

The residual gas density for proton-proton runs in the LHC interaction regions IR1, IR2, IR5 and IR8 has been estimated using the VAcuum Stability COde (VASCO) [1] for the two scenarios of machine start-up and after electron scrubbing [2]. The results can be used for estimation of background noise to the LHC experiments for those operation phases.

Accelerator Technology Division

CERN
CH - 1211 Geneva 23
Switzerland

Geneva, 18 September 2003

$1 \times 10^{13} / \text{m}^3$

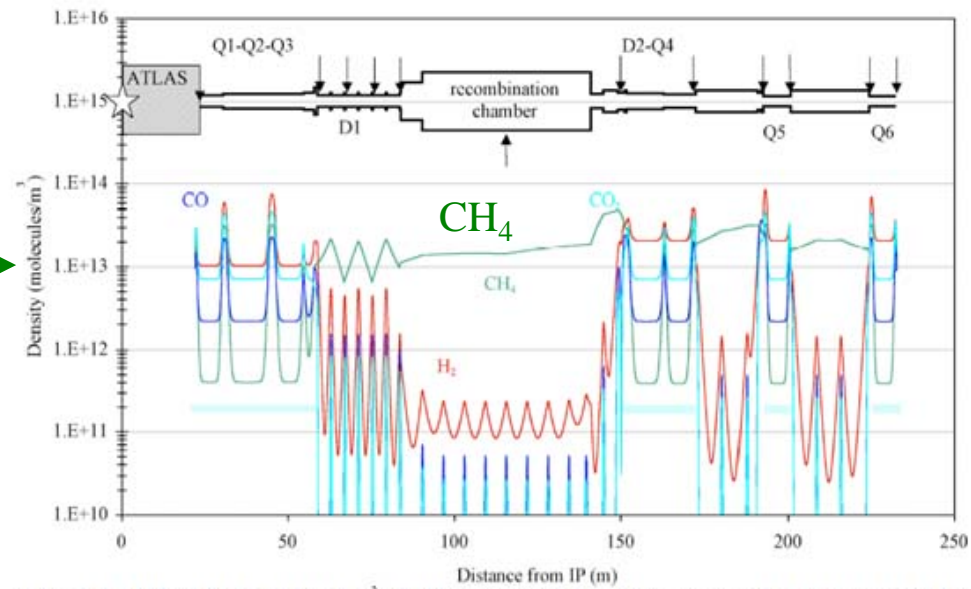

Figure 3: Residual gas density (molecules·m⁻³) profile in the interaction region IR1, for the “machine start-up” period, at 1/3 of nominal beam current and top energy. The sections of the beam pipe at CT are underlined with a light blue marker. The interaction point is indicated with a star. The arrows represent the lumped pumps. The data are presented for on side of the experimental region, since the geometry is symmetrical with respect to the interaction point.

$1 \times 10^{11} / \text{m}^3$

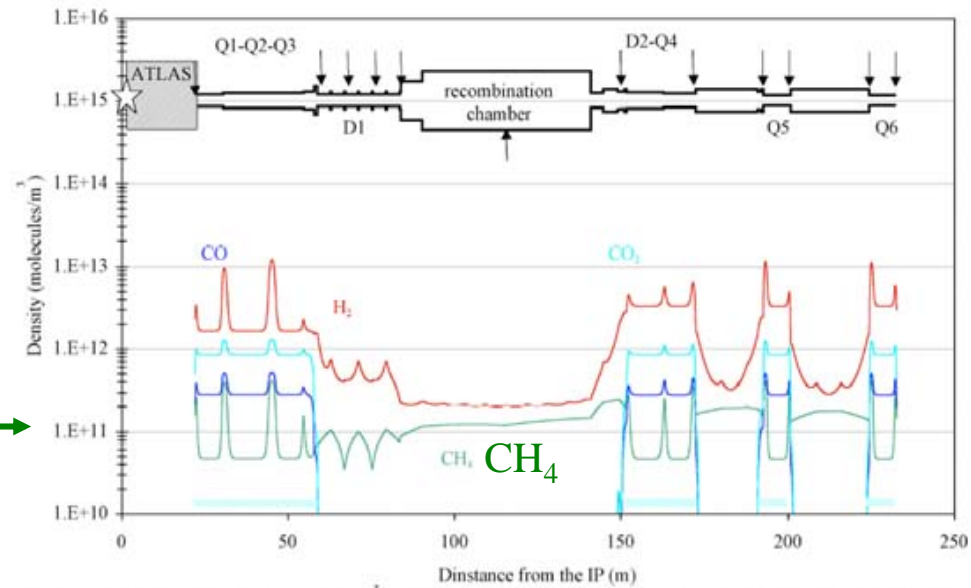

Figure 4: Residual gas density (molecules·m⁻³) profile in the interaction region IR1, for the “after machine conditioning” period, at nominal beam current and top energy.

Summary 3 (on trigger)

The trigger pulse will be made by

- 1) $\text{arm \#1} * \text{arm\#2} * \text{machine signal}$
- 2) $(\text{arm\#1} * \text{machine signal}) \text{ OR } (\text{arm\#2} * \text{machine signal})$

- 3) $\text{arm\#1} * \text{machine signal} * \text{ATLAS trigger signal}$
(to be discussed with the **ATLAS** people)

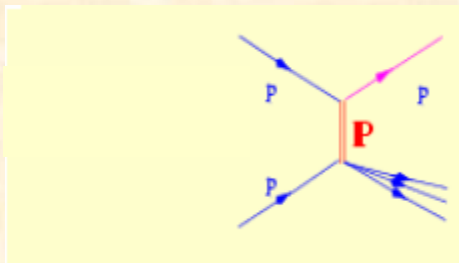
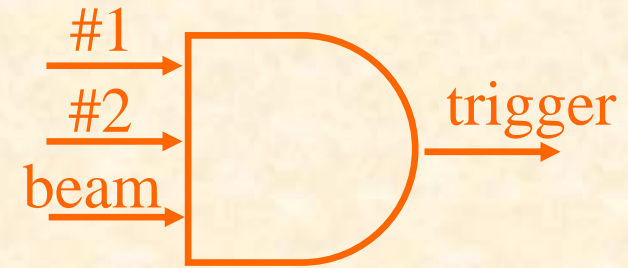

Single diffraction

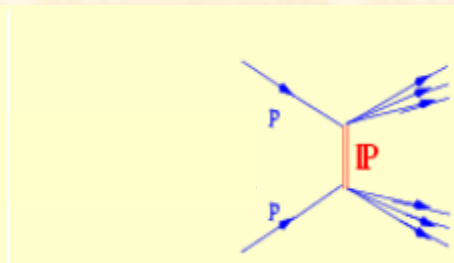

Double diffraction

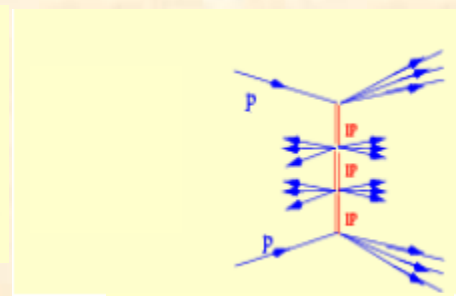

Diffractive + many pions production

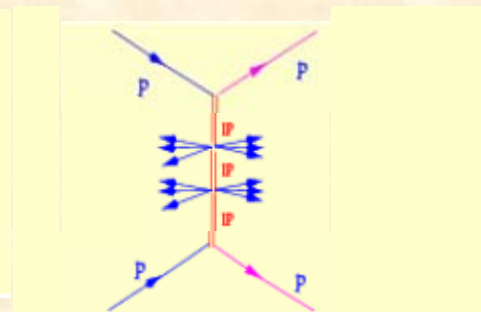

Many pions production

The beam gas contamination

We estimate beam-beam: beam-gas = 2 : 1 @ L= 10²⁹ and **early stage**
but at the later stage = 1: 0.01 @ L= 10²⁹ and **later stage**

At **the beginning**, taking account of the acceptance for the beam-gas event by the M.C. calculation, we found that the ratio between
beam-beam : beam-gas = 10 : 1 (**contamination is ~10%**)

However if we will take arm#1*arm#2 trigger, it will be reduced to 1000:1.

Unfortunately at that time we may lose pure single diffractive event.

Therefore we must repeat the data-taking **after machine conditioning**.

However **the above value** is estimated for the high luminosity case and in fact in the early low luminosity case, the gas in the beam pipe would be not so much. We must ask a calculation to the CERN vacuum group.

Concluding Remarks

- ★ A very important data will be obtained without change of present LHC projects.
- ★ The data will become extremely useful not only for cosmic ray physics, but also for high energy physics.
- ★ The data will be used for a long time.

- **Other remarks**

- * We also want to measure N-N or p-N or or N-Fe collisions. (N= N₂ and O₂)
- * We also get another important data on neutrons and K⁰s and **the inelasticity.**

Schedule

- We will write the **Technical Design Report** as soon as possible and come to present it in the early 2006.
- We will start the construction of the detector to make the beam test in the **summer of 2006**.
- During that time, we will discuss with the vacuum group of the LHC and the operation group of the LHC.
- Our detector will be also useful to know the collision rate between the beam-beam and beam-gas collisions at the beginning.

Coverage of $P_{T\gamma}$ and E_γ range

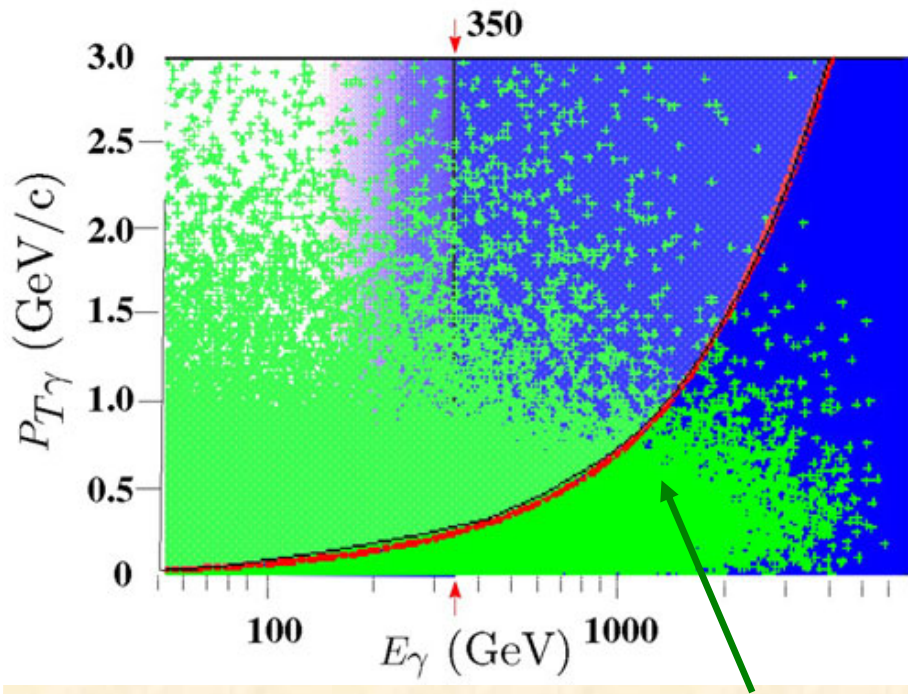

Accessible region

Photons in the $P_{T\gamma}$ - E_γ plot

Red line corresponds to the beam pipe

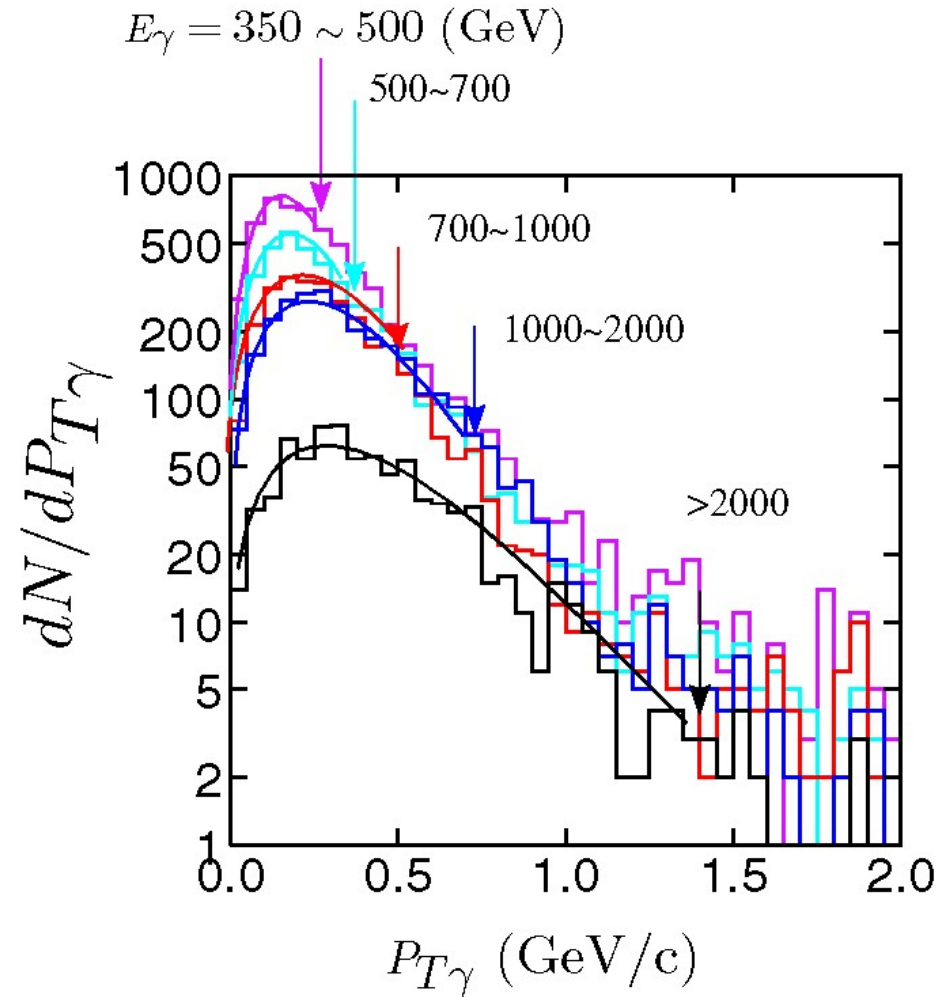

The number of γ detected depends on the geometrical acceptance

Difference in Artificial Two Models

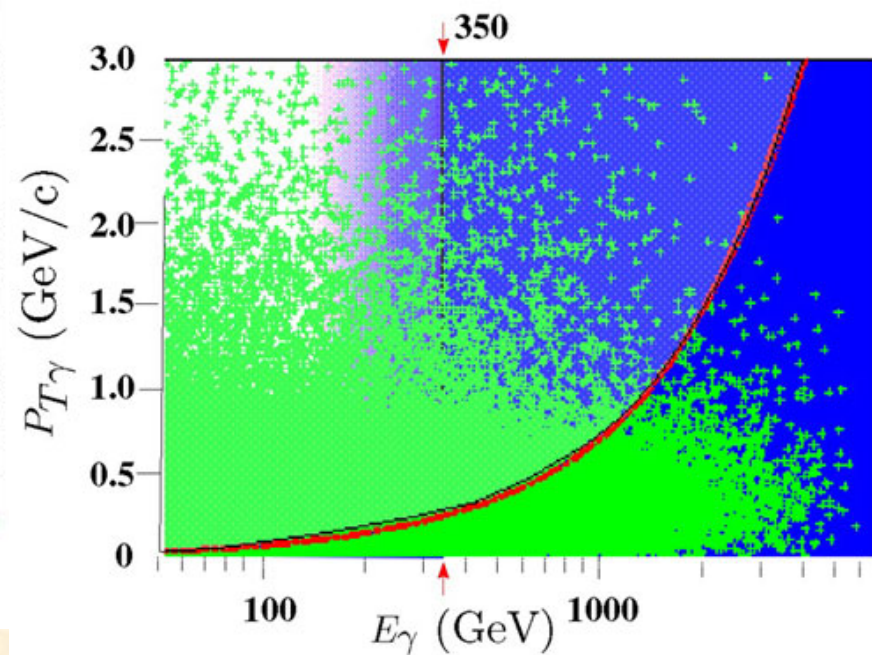
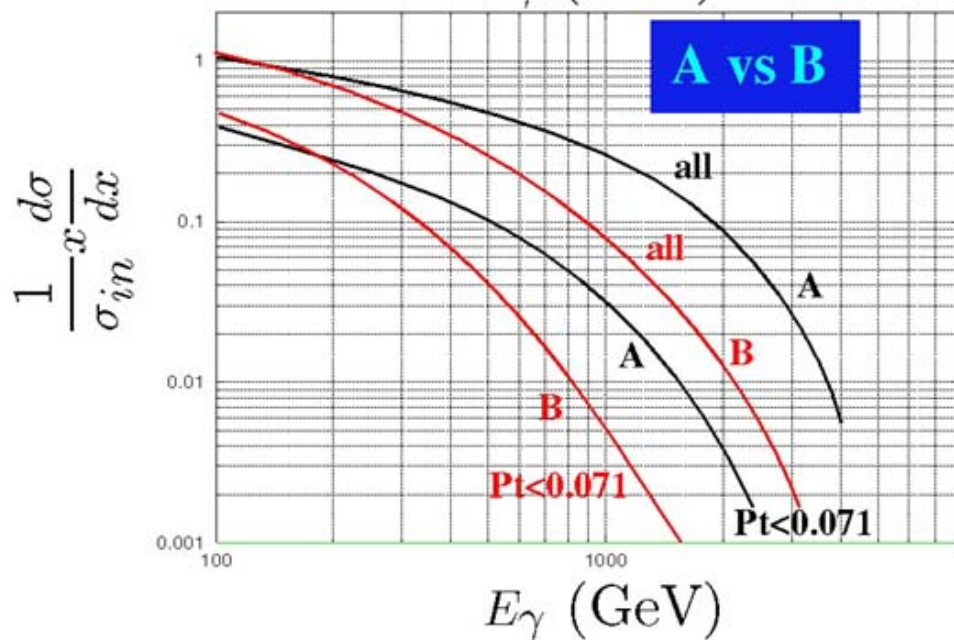
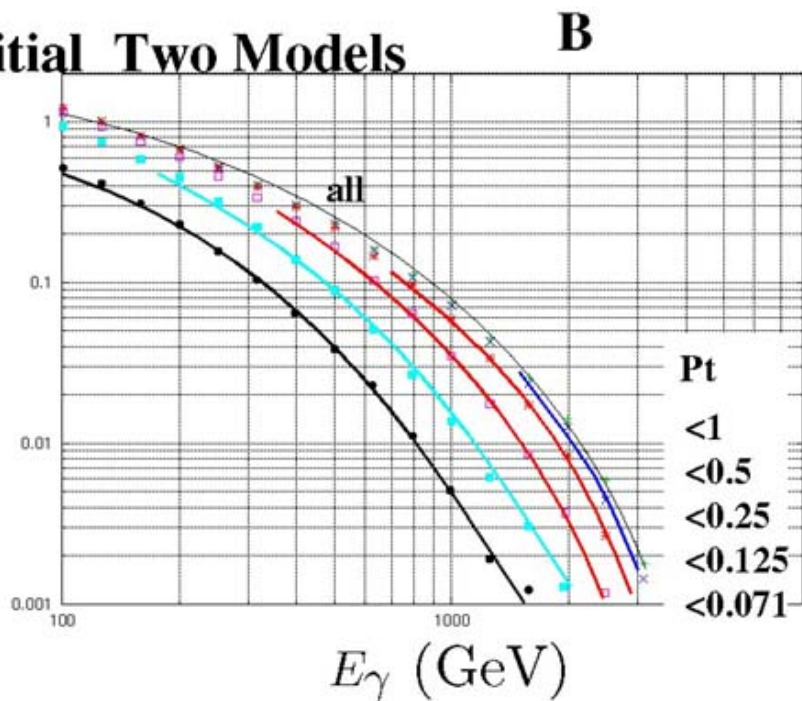
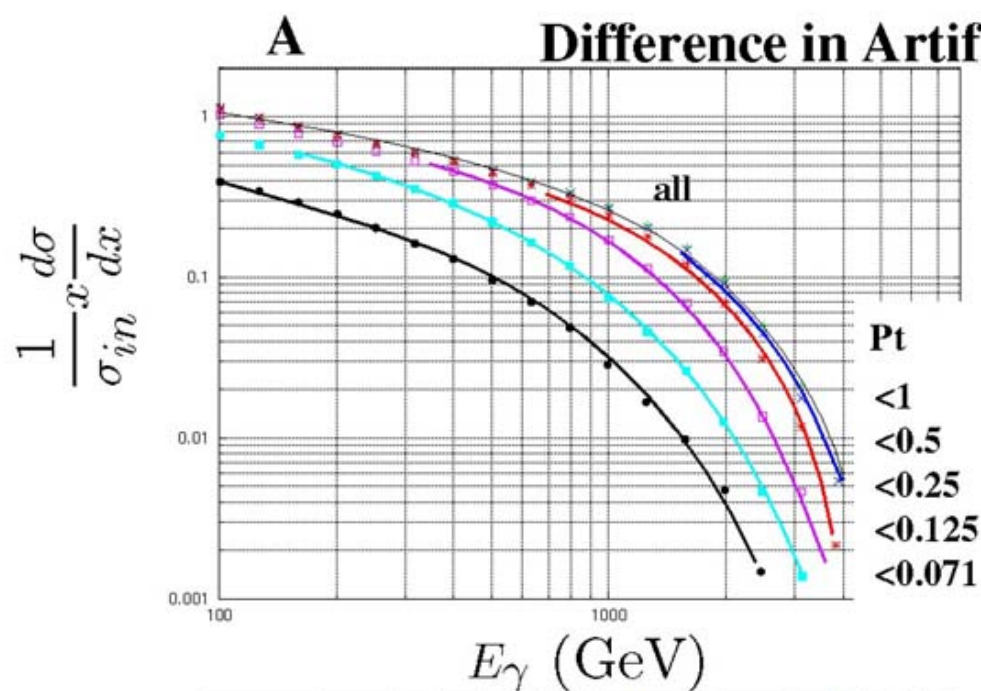

How to calibrate the absolute number of particles like 10^5

1) The maximum current 100pC is determined from the ADC.
The maximum countable value of the ADC is 100pC.

2) For the shower particles 10^5 , 25 photo-electrons $\times 10^5$ particles $\times 1.6 \times 10^{-19}$ Coulomb $\times 250$ (gain) = 100 pC. So the gain of the photomultipliers must be set at 250. We searched corresponding voltage to the gain 250 from the catalogue and found that it should be around 450V.

3) Then we have searched the Minimum Ionizing Particle (MIP) peak by using β -rays. For the HV -1500 Volts, we have seen the peak. At that voltage, the gain of the photomultiplier is 2.3×10^5 . The peak of the 1 MIP corresponds to 25 photo-electrons and 0.9 pc.

4) So in actual experiment, we expose our calorimeter at the muon beam at first, under HV=-1500V. Then reduce it to -450V. Then **the muon single peak corresponds to 900 particles @-450V.**

5) The minimum resolution of the number of particles is estimated as to be 25 particles. But this value depends on the electric noise and pedestal. Thus we can say by **using the modified photomultiplier, the number of particles in a range of $\sim 100 - 100,000$ MIPs can be measured, using almost linear range of the gain of the photomultiplier.**

Peak of Beta Ray @ -1500V

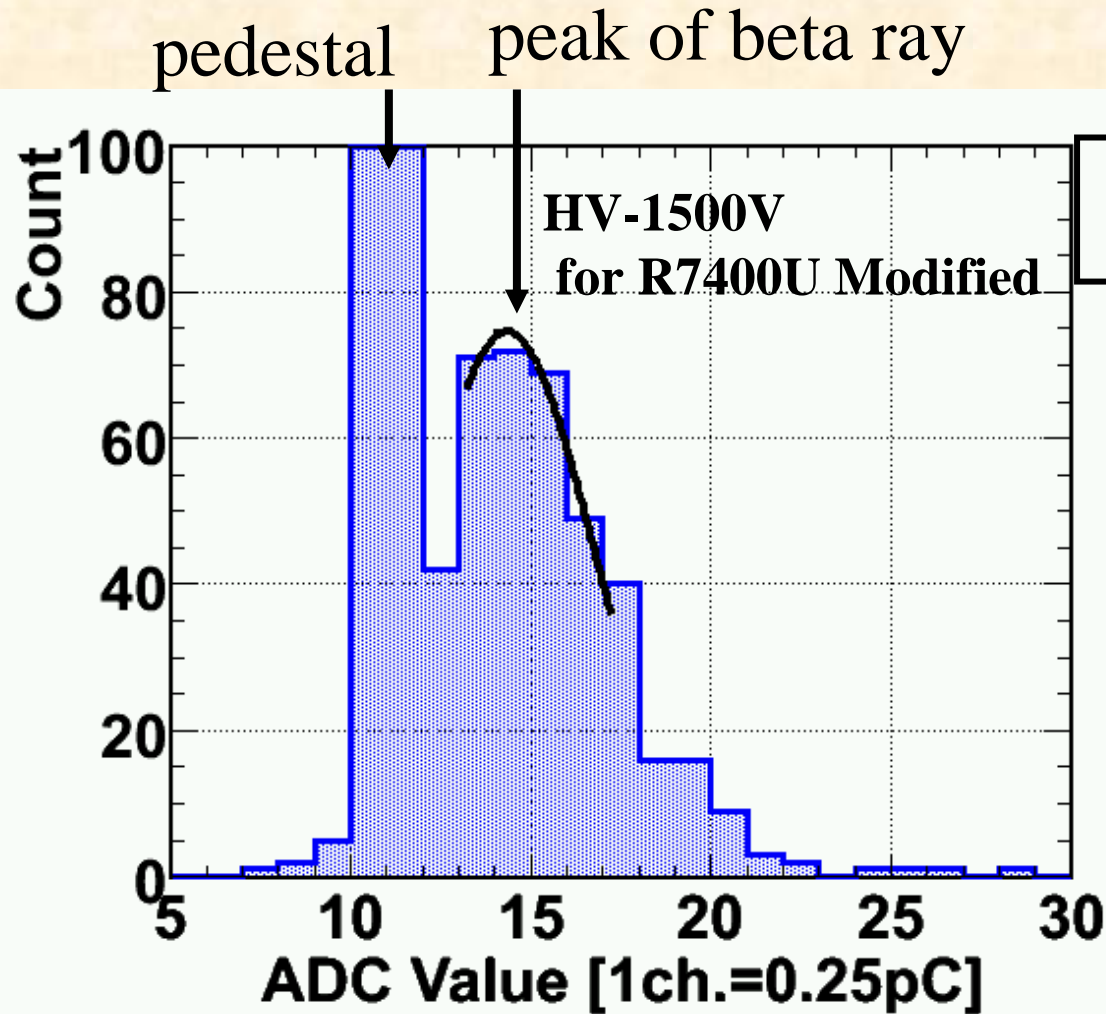

Beta Ray Source

$^{90}\text{Y} :: E_{\text{max}} = 2.282\text{MeV}$

peak of beta – pedestal
= 3.7 ADC counts



MC simulation

dE peak of beta

= 0.52 ~ 0.57 MeV

dE peak of 150GeV/c Muon

= 0.45 MeV

Neutron Energy Spectrum of 20mm Calorimeter at beam center

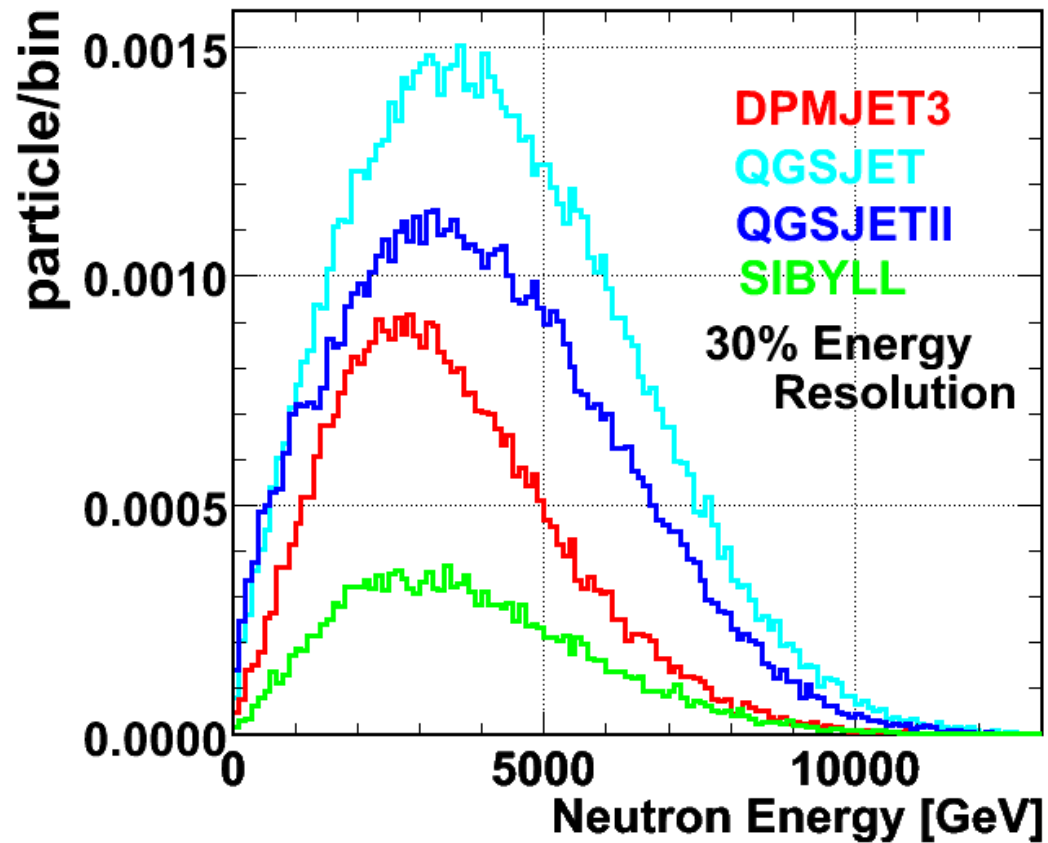

Neutron spectrum by different model

Neutron energy resolution

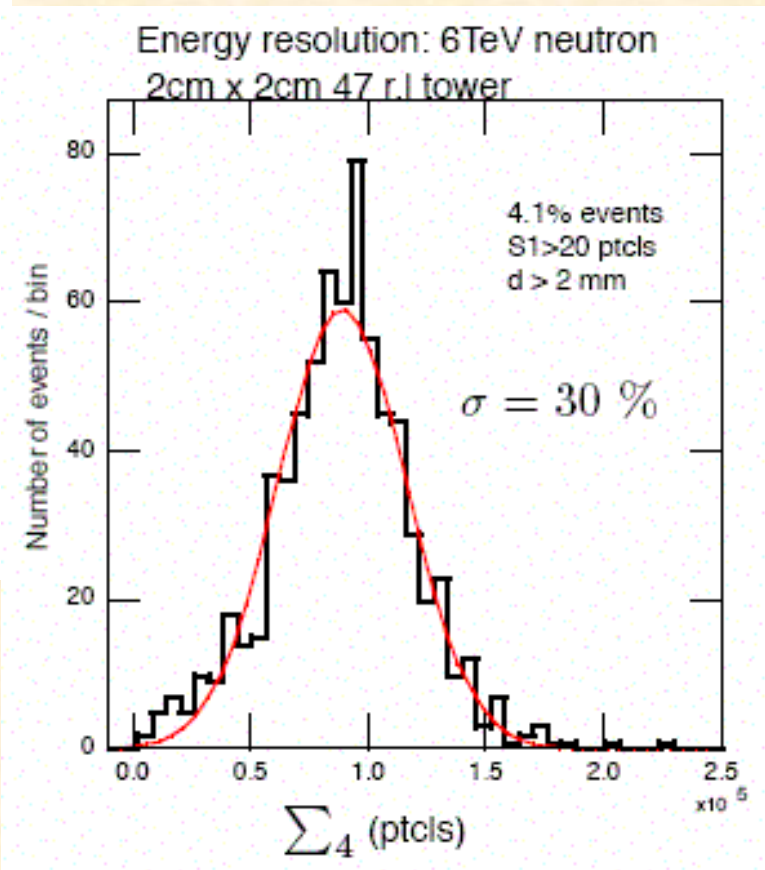

Beam pipe effect

- + particles from the collision point
- particles from the beam pipe

3000 interactions: all particles

