

REVIEW OF EXPOSED EQUIPMENT IN THE LHC : A GLOBAL VIEW

T. Wijnands, G. Spiezia, RADWG members
CERN, Geneva, Switzerland

Abstract

Standard radiation test methods and design procedures have successfully been over the last years to make a large amount of electronics for the LHC accelerator radiation tolerant. This paper will review the underlying theoretical models, test procedures and the assumptions that were made. It will be shown how system designers have managed the risk associated to radiation damage in their systems and designs for the LHC tunnel. Finally, an overview of equipment exposed to radiation in critical LHC areas is presented and the most critical systems are high-lighted with respect to system criticality and operational impact in case of failure.

INTRODUCTION

Already in the early phase of the design of the LHC (1991-1996) it became clear that the different parts of the LHC experiments (detectors, electronics, mechanics and infra-structures) would be exposed to high levels of radiation. At a total dose of 10 Mrad and fluences of 10^{14} n/cm² per 10 years, the use of commercial off-the shelf electronics is excluded for use in the detectors. It was therefore decided to build custom designed radhard electronic circuits [1] for almost all LHC experiments. These electronics are based on a technology which is using deep submicron processes with enclosed transistor topologies and guard rings [2]. Compliance with the radiation requirements was eventually successfully obtained using these techniques [3, 4].

First estimates of the radiation levels for the accelerator showed that the radiation levels in the tunnel and in the underground areas terms would be dominated by beam-gas interactions and that they would be below 10 kRad for 10 years operation [5]. Based on this information, it was decided to use either turnkey systems that were commercially available or to build radiation tolerant electronic boards and systems from commercially available parts.

These electronics were integrated in the accelerator tunnel, in some of the underground areas close to the beams and in the UA klystron galleries (following the end of LEP operation and the subsequent removal of the RF cavities). This resulted in a reduction of the power consumption, a reduction of the cabling and it improved the S/N ratio of the signals. In parallel, resources were made available to verify the radiation tolerance of the electronic equipment in the tunnel.

This paper will globally review some of the efforts that were undertaken by the electronics engineers in various equipment groups in the period 1999-2008. The theoretical basis for the radiation tolerance assurance studies that have been conducted over the last 10 years

will be given first followed by a discussion on radiation tests and procedures that were followed. This issue of statistical uncertainties and the associated management of the risk related to radiation will be discussed focussing on the electronics in the LHC tunnel.

Finally, the issue of the non-radiation tolerant electronics in the underground areas of the LHC will be addressed and the results of an equipment survey will be presented.

THEORETICAL BACKGROUND

Soft Single Events

In order to assess the risk of soft single event error rate in the LHC, the Simple Sensitive Volume model (SSV) [6,7] has been used. In this model, the energy loss by ionization from a nuclear interaction within the Silicon is computed via the Monte Carlo simulations of the generation and transport of nuclear fragments. Since the explicit device structure and the operational modes are not considered in this model, its usage is per definition limited. Nevertheless, for the generation of electronics that is used in the LHC accelerator (based on standard 5 V CMOS/TTL logic at 0.35 micron) the method gives a first impression of the soft error rate that expected during operation of the accelerator.

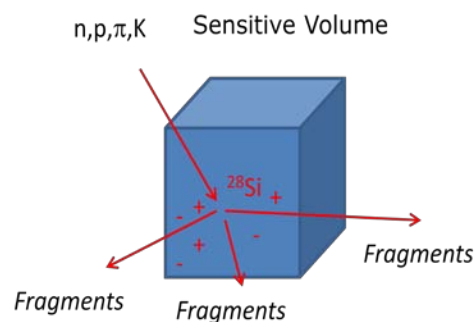

Figure 1: SSV Model showing an inelastic reaction of a hadron with ²⁸Si.

In the SSV model, nuclear interactions of incident hadrons with ²⁸Si atoms inside a sensitive volume (SV) are simulated with a Monte Carlo code. If a nuclear reaction occurs, the energy deposition through ionisation (E_{dep}) from the recoils (fragments in figure 1) is calculated and compared to a predefined critical value (E_{crit}). The critical value E_{crit} is defined as the energy value above which a soft error will occur in the device. For most of the electronics of the generation that are presently installed in the accelerator, this critical value is around $E_{crit} = 0.8$ MeV while for more recent devices that are powered at 3.3 Volts or lower, the value of E_{crit} is in general lower.

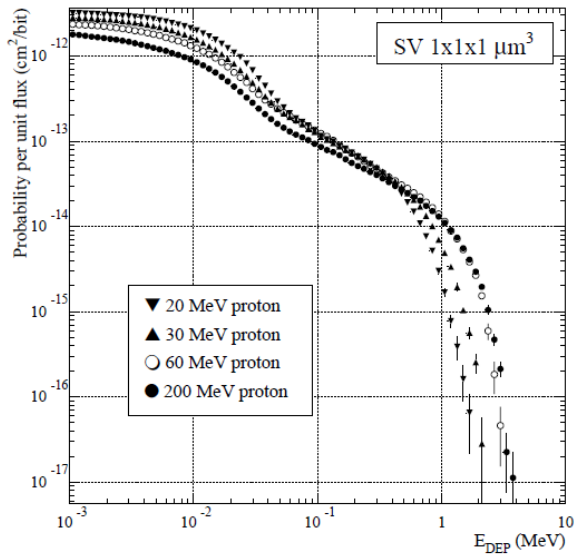

Figure 2: Energy deposition probability for protons at different energies. The curve shows the probability to have within a SV of $1\mu\text{m}^3$ an energy deposition greater of equal to E_{dep} . (figure from ref [7])

Figure 2 shows the energy deposition probability when protons at different energies are interacting with the silicon inside a sensitive volume of $1\mu\text{m}^3$. The first observation is that the maximum energy that can be deposited inside the SV is limited even if the energy of the incoming particles increases. In the figure, the maximum energy deposited by a 60 MeV proton is almost equal to the energy deposited by a proton of 200 MeV. This suggests that the soft error cross section as function of the incident particle energy will eventually saturate at a given energy of the incoming particle which is indeed what is observed experimentally (figure 3).

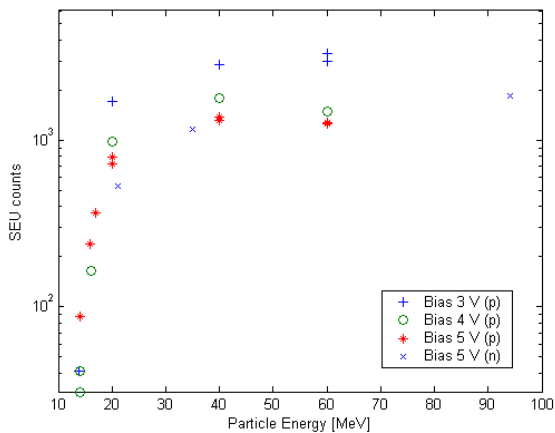

Figure 3: Proton, neutron cross section for a $0.5\mu\text{m}$ SRAM under different biasing conditions (TC 554001 AF from Toshiba).

It also suggests that protons at energies of 60 200 MeV will already deposit energy E_{dep} which is very close to the theoretical maximum value.

For soft errors in the most sensitive components, the region $10^{-1} < E_{dep} < 1$ MeV, is the main region of interest. Figure 2 shows that in this region there is very little difference in the energy deposition probability for a low proton at 20 MeV and a high energy proton at 200 MeV. This suggest that soft errors can be studied equally well with low energetic protons at an energy of 60 MeV.

There is the difference between protons and neutrons to be addressed. More than 95% of the high energetic hadron flux in the LHC tunnel and underground areas is made up of neutrons and protons only account for a few percent of the hadron flux. However, when the proton energy is above the Coulomb repulsion threshold energy of 5 MeV there is no difference in the SV model between neutrons and protons because ^{28}Si is iso-spin symmetric.

The final contribution to the soft error rate discussed in the SSV model in [7] are the (n,α) reactions in compounds containing a specific isotope of boron, ^{10}B . This topic was extensively discussed in the radiation community some 15 years ago and a good review can be found in [8].

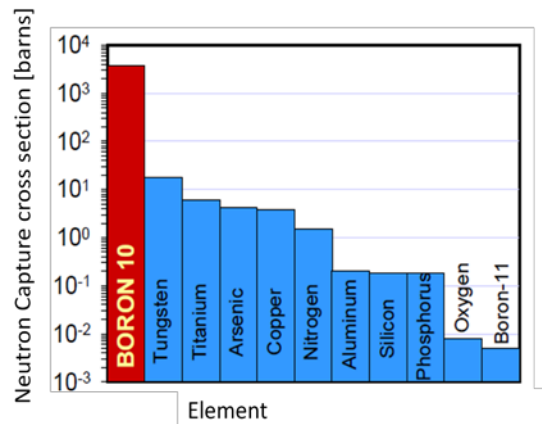

Figure 4: Neutron Capture cross section for various elements that are used in the fabrication of semiconductor devices.

This particular isotope of Boron has an extremely high neutron capture cross section (figure 4) as compared to the other elements that are used in the fabrication of semiconductors. After capturing a low energy neutron, the Boron nuclide becomes unstable and emits a 1.47 MeV alpha particle and a 0.84 MeV Lithium recoils. The alpha particle can generate sufficient ionisation to cause a soft single event in a device.

Isotopes of Boron are extensively used in the semiconductor fabrication to dope substrates and wells, while Boron Phospho Silicate Glass (BPSG) is used as dielectric layer between the silicon and the metallisation layer of the chip (figure 5). In the late 90's it became clear that the neutrons from cosmic rays were making a

considerable contribution to the soft error rate in consumer electronics due to the presence of BPSG [9-13].

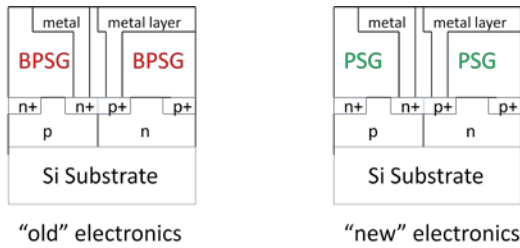

Figure 5: Replacing the BPSG layer between the silicon and the metallisation layer by PSG leads to sharp reduction in the soft error rate from alpha particles due to thermal neutron capture in Boron.

The semiconductor manufacturing process was changed and BPSG was replaced by PSG material in the dielectric layer. This resulted in a reduction of almost 90% in the soft error rate from thermal neutrons.

Unfortunately, the controls electronics for the LHC machine were partially constructed during the transition phase and it cannot be excluded that some parts with BPSG in the dielectric layer are still in use in some of the electronics designs for the accelerator. In that case, the soft error rate of a system will be underestimated if only high energy hadrons are considered and if a lot of thermal neutrons are present. In such an exceptional case, the straightforward solution is to cover the part with low energy neutron shielding (mold compound with BPSG filler instead of normal silica).

Altogether this leads to the model prediction that soft error rate in a neutron dominated environment such as the LHC tunnel can be approximated by folding the hadron (neutron) spectrum at the location of the equipment with the soft error cross section of the device. The soft error cross section can be measured experimentally with a proton beam of at least 60 MeV.

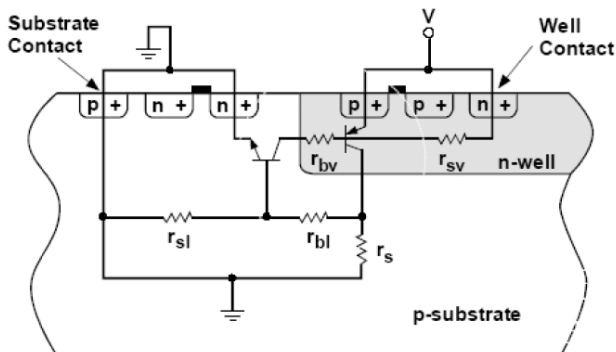

Figure 6: Single Event Latchup (SEL) can occur where parasitic pn, np and bipolar junctions in CMOS exist. The figure shows the equivalent latch up circuit (from [14]).

Hard Single Events

In the region $E_{dep} > 1$ MeV, the SSV model predicts a possible difference between hadrons of different energies and this area is of most relevance for hard errors (SE Latch Ups, SE Burn Out and SE gate rupture). The threshold value of E_{dep} for these events is in general higher than those for soft errors because the error mechanism involves a much larger part of the CMOS device. For SEL for example, the latch up path is via 2 neighboring pnp or npn structures (figure 6, [14]). This is also one of the reasons why it is almost impossible to make a simple model to determine the susceptibility of components to hard single events.

Up front, it is impossible to determine if a specific device will be sensitive to hard single events in the radiation environment of the LHC which is why all devices that are potentially susceptible must be experimentally tested. As discussed above, proton testing can provide a first impression on the susceptibility of the device but the statistical uncertainty will be large since only very few events will deposit a maximum of energy inside the silicon. The uncertainty can be reduced by using protons of 250 or 500 MeV. Eventually, a full characterization of the device can be obtained experimentally by irradiation with Heavy Ions (HI). Heavy Ions are causing direct ionization in the Silicon and the E_{dep} can easily exceed the maximum value that can ever be achieved in the LHC. This allows for a complete characterisation of the device and to study the influence of temperature, duty cycle de rating voltage etc.

The drawback is that HI irradiation is costly, more complex and labour intensive. For this reason, only a few parts with suspected high sensitivity to hard errors have been irradiated with HI.

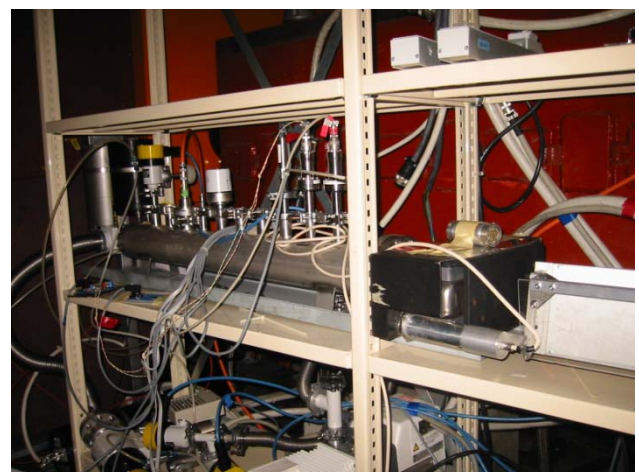

Figure 7: Exposure of a set of candidate pressure transducers for the LHC vacuum system in the TCC2 facility – CERN North Experimental Hall BA80.

To achieve nevertheless a significant statistical certainty on the absence of hard single events, equipment owners were invited to expose their complete system under identical operating conditions as those in the LHC in a target area. In the period 1998-2005, the TCC2 target area was used (figure 7), while the CNGS target area has been in use since November 2007 [15]. Although it remains difficult to put these test in perspective against tests with mono energetic, single particles species, it helped to increase the confidence in the radiation tolerance of the equipment.

Total Dose

In the baseline LHC design, radiation levels in terms of total dose have been a constraint in the equipment integration. This means that complex logic CMOS devices are mainly situated in the regular ARCs where the dose levels are low and of the order of a few Grays per nominal year. For these devices, no dedicated total dose tests were carried out. Low energy proton data was used instead to get a first impression on the tolerance to total dose.

Some electronic equipment and some materials in the LHC are located in the DS or LSS regions of the tunnel where they are exposed to annual radiation doses of the order of 10^2 to 10^3 Gy (LHC nominal). For this equipment special total dose tests were carried out with gamma rays from a ^{60}Co source.

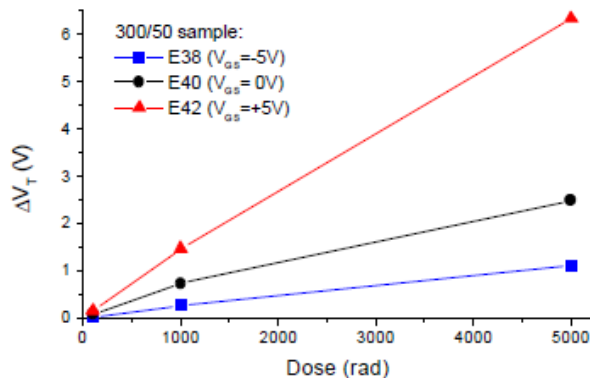

Figure 8: Threshold voltage (V_T) shift on NMOS transistors used in the RADMON system for the LHC during gamma irradiation using different biasing conditions (Gate-source V_{GS} voltage at -5V, 0 V and +5V) [16].

There are at least 2 major issues that have to be considered for radiation damage to CMOS electronics from total dose which are the biasing conditions of the device and the dose rate dependence (and subsequent annealing behaviour).

Biasing conditions of the device are very important and in general some improvement is observed when parts are unbiased (figure 8). However, CMOS biasing effects

under irradiation is a very complex subject which is why this needs to be checked on part-by-part basis.

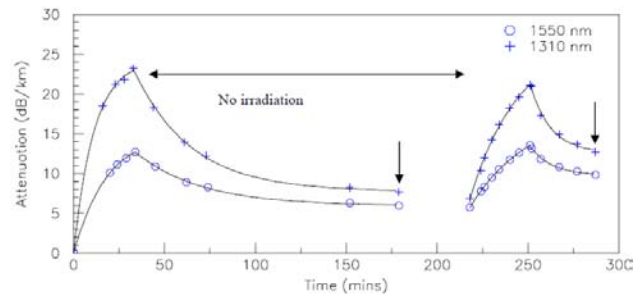

Figure 9: Dose rate effects on the Radiation Induced Attenuation of Ge-doped graded step index fibres for communication, presently in use in the LHC tunnel [17].

Some failure mechanisms can be induced by irradiation at different dose rates because hole traps and interface traps build-up and anneal on different time scales. Dose rate effects can be observed on almost any CMOS device as well as on optical fibres (figure 10). Bipolar linear transistors are well known to exhibit Extreme Low Dose Rate Sensitivity (ELDRS). This means that the device degradation at the end of a low dose irradiation is higher than the device degradation followed by a room temperature anneal for a sufficiently long period of time.

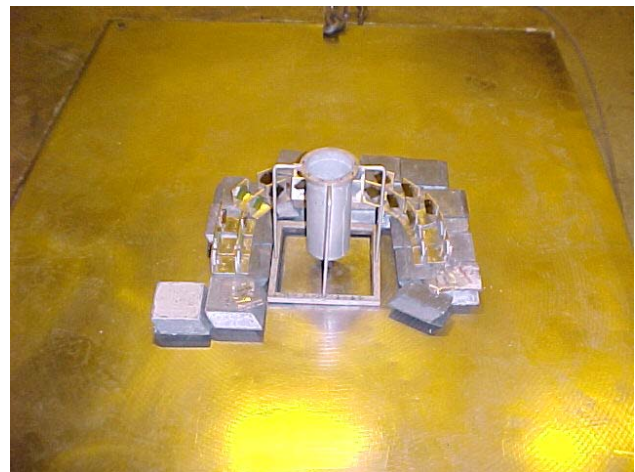

Figure 10: Total dose Irradiation of paint samples for the TAN absorbers in the LHC to 1 MGy.

Material damage from total dose is not an issue that will appear in the first years of LHC operation because materials are in general much more radiation resistant as compared to electronics. However, experience from other proton accelerators at CERN has shown that replacing degraded insulation for cables and magnetic coils will eventually be required in the LHC and that verification of the radiation resistance of such materials is of importance.

For cable insulating materials, the end-point criterion is defined as the dose at which the elongation at break is 100% or more. For thermosetting and thermoplastic

resins, the end-point criterion is the dose at which the ultimate flexural strength of the material is 50% or more of the initial value for the non- irradiated sample. For items such as motors, glass, oils and paints, it proved to be impossible to define a standard definition of the acceptance so irradiation test results were debated with the equipment owners on a case to case basis following operational tests and/or visual inspection of the irradiated materials (figure 10). In all cases, the compilations of 10 years radiation test damage data on a wide range of materials was used a guideline [18].

Displacement Damage

Displacement Damage (DD) in the LHC underground areas is caused by protons, neutrons and electrons and affects, for example, the gain of bipolar transistors, optical detectors and some types of light emitting diodes. The threshold for the onset of DD is rather high, around 10^{11} n/cm² (1 MeV equivalent) and this value is unlikely to be attained in the next few years of LHC operation. The underlying radiation effect is the energy transfer from an incoming particle to a lattice atom which creates clusters of damage which reduce the minority carrier lifetime.

As with total dose damage, it is not straightforward to predict how if a device or system will be sensitive to DD without a radiation test. For the LHC, we concentrated mainly on the systems that make extensively use of opto electronics such as laser diodes in the BLM system and the opto-couplers in various switched mode power supplies.

RADITION TESTS

Standard Test procedures

It is preferable to conduct all radiation tests in line with Standard Test procedures and in calibrated test facilities to have a straightforward comparison with other data and to allow for the sharing of data between various groups. A number of radiation test procedures exist for all 3 different types of radiation damage and they vary in their recommendations depending on the type of application (military, space, consumer electronics) at hand.

Over the last 10 years, CERN equipment groups undertook a considerable effort to irradiate all equipment “as good as practically achievable” in line with standard procedures. For single event studies, the standard is the ESA/ECC Basic specification No. 25100 (“Single Event Effects Test Method and guidelines”) [19] while for Total Dose and DD tests, the ESA/SCC Basic specification No.22900 (“Total Dose Steady State Irradiation Test Method”) [20] is used. In practice, it appeared to be necessary to study each case individually as it was almost never possible to respect these recommendations in full. The use of safety factors was deliberately excluded.

Test Facilities

The use of high quality test facilities calibrated against international standards is mandatory to achieve a set of

coherent results from radiation test. It is also the only way to compare results within the radiation community at large.

For proton irradiation, CERN has collaboration contracts with UCL (Université Catholique de Louvain, UCL) in Belgium and with the PSI (Paul Scherrer Institute) in Switzerland. These institutes consider the use of their facilities by CERN equipment group as part of their contribution to the CERN project and to LHC in particular.

The Light Ion Facility (LIF) at UCL [21] provides protons at energies up to 62 MeV. The energy degradation is achieved by inserting plastic slabs (10 different thicknesses, 3 of each). At the location of the DUT, the protons energy is between 9.3 and 62 MeV. The proton beam has a flat profile with homogeneity of $\pm 10\%$ on a circular beam spot with a diameter of 10 cm. The maximum proton flux is 5×10^8 protons/cm²s. The beam profile is determined using a diode in a water phantom. Large proton fluxes are measured with a transmission chambers and an annular detector calibrated against a precision faraday cup. For lower proton fluxes, scintillators are used.

The Low energy Proton Irradiation Facility (PIF) at PSI [22] provides protons with energies between 6 to 71 MeV and a maximum proton flux of 5×10^8 protons/cm²s. The proton beam has a flat profile with homogeneity of $\pm 10\%$ on a circular beam spot with a diameter of 5 cm while the beam spot has a diameter of 9 cm.

The high energy Proton Irradiation Facility (HIF) at PSI provides protons with energies of 235, 200, 150, 100 and 70 MeV and a maximum proton flux of 5×10^8 protons/cm²s.



Figure 11: Total Dose Irradiation of cables for the powering of the inner triplet magnets of the LHC.

Total dose test have been performed at the ⁶⁰Co irradiators at CEA-Saclay which have the advantage of providing a large range in dose rates from 50 Gy/hr - 30 kGy/hr. Irradiations take place in air and it is possible to irradiate very large objects (figure 11). Calibration of the

source is carried out with an ionisation chamber calibrated against COFRAC standards.

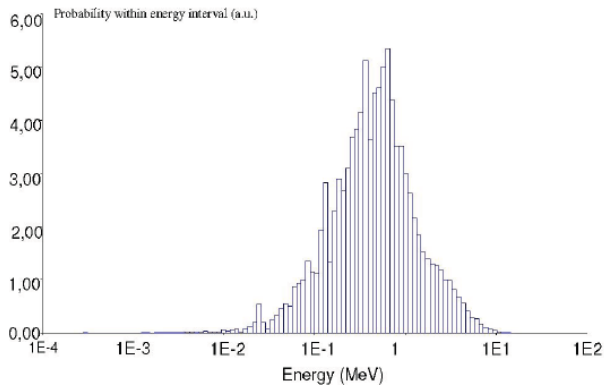

Figure 12: Neutron spectrum of the PROSPERO reactor (bare core) (figure from reference [23]).

Most of the DD tests were performed in a nuclear reactor PROSPERO at the CEA-Saclay [23]. Irradiations are performed in air up to a total neutron fluence of 10^{14} n/cm² (1 MeV eq. Si). Dosimetry is carried with a wide variety of passive dosimeters such as PIN diodes, TLDs, Al₂O₃ and gamma spectrometry in line with the ASTM E181-98 standards.

Acceptance criteria

In the absence of a strict overall review policy for electronics designs, the acceptance criteria for electronics designs were determined on a case to case basis in close collaboration with the equipment groups and the technical coordination of the LHC project.

This proved to be a difficult task, first of all since the awareness of the potential consequences of radiation damage effects was not generalised. Furthermore, many equipment groups are entirely dependent on their contractor outside CERN and have no in-house design capability to fabricate an appropriate on line test set up. Some parts or designs were not tested or had incomplete radiation test results, others were eventually used in operating conditions that were very different from those under which the radiation test was performed. In other cases, electronic parts were added to the design in a later stage without being verified on their radiation tolerance.

Another important issue is the quality assurance of the series production and the procurement of the parts that are used in the designs. Although lot acceptance tests were recommended, this was not always possible because of the costs for the boards and the number of hours needed in a radiation test facility. In addition, it was not always possible to irradiate a sufficient large amount of parts/designs in order to reduce the statistical uncertainty to an acceptable level.

Finally, the risk (defined here as probability multiplied by the consequence) of the radiation damage to

equipment or system was considered in the context of LHC operations (see also below).

The discussions on radiation test results and the final decisions by the equipment groups were summarised in total of 7 public LHC radiation days. The proceeding of these events can be found on the CERN indico pages [24].

RISK MANAGEMENT

As pointed out in the previous sections, the use of electronics in areas with radiation is associated with a certain risk. This risk can be controlled to a certain level using dedicated designs and design technologies, thorough radiation testing and strict QA for the series production and procurement of spares. Unfortunately, the risk can never be eliminated entirely.

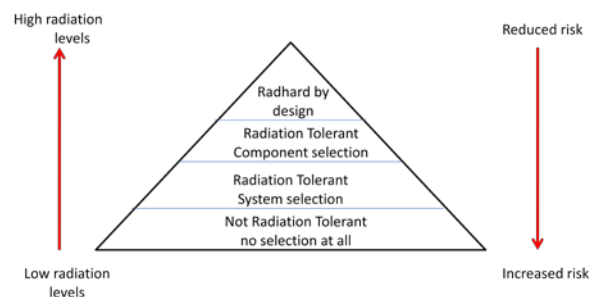

Figure 13: Risk pyramid.

Figure 13 puts the different approaches in perspective. Some equipment groups preferred to expose standard commercial designed systems to radiation without any pre-selection. From experience, the success rate in this case is extremely low and the associated risk very high because almost no QA can be achieved. The reason for early failure is almost always due to Single Events which excludes the study of cumulative damage.

Much better results have been obtained when a pre-selection of the system is made. The pre-selection procedure can be based on a study of the functionality of the device, the presence of complex logic, powering and a study of the datasheet as provided by the manufacturer. Radiation testing is required to assure the absence of hard single events and to get a first impression of the soft error rate. The radiation induced soft errors can then be accounted for at the level of the system or in the control room. The acquisition system of the WIC (warm magnet interlock controller) falls in this category for example [25].

The highest success rate was obtained when commercial parts were selected on their radiation tolerance before a prototype was built. This was the case for the QPS system, the BLM/BPM system, the BIC system, the signal conditioner for the cryogenics and the RADMON system.

Radiation hardness by design was only used for LHC experiments as discussed in the first section. In some particular case, electronic designs for the tunnel used

radiation hard parts that were designed for the LH experiments (voltage regulator for the BPM system for example).

EQUIPMENT OVERVIEW

LHC Tunnel Electronics

There are 6 distributed control systems in the tunnel that were build from individual parts taking radiation tolerance into account as a design constraint (radiation tolerant designing via component selection in figure 13). For these systems, the parts were carefully selected on their radiation tolerance via numerous tests. Performance degradation of the parts is accounted for at the level of the system so that part degradation does not lead to a decrease in system functionality.

The **Cryogenics Instrumentation Electronics** was amongst the first electronic designs to be exposed to radiation in the TCC2 target area [26]. This system controls the temperature of the superconductor magnets, beam screens and the HTS current leads using more than 10 000 cryogenic sensors and actuators. The low signal amplitude obtained when measuring cryogenic sensors require signal conditioning in close proximity to the sensors which is why the cryogenic instrumentation is distributed uniformly along the 27 Km and located in crates placed under the main dipoles.

Electronic parts such as the WorldFIP interface [27] were tested outside CERN with single events beams which provided useful information for other users. Mitigation Techniques in the logic include Triple module redundancy on FPGA logic and frequent refreshment of WorldFIPagent's SRAM memory. Finally, the power supplies and thermal dissipaters have been overdesigned to account for increased current consumption due to total dose effects [28].

The complete was exposed to radiation in the target areas of the SPS at several occasions and operated without any interruptions from radiation damage until it reached the total dose limit.

A similar design approach was followed for the **QPS Electronics** (i.e. Quench detection system, the Quench Heater Powering and the Data Acquisition and monitoring) [29]. For the Quench Heater supplies, all parts (Aluminium electrolytic capacitors, NE556 bipolar timers & linear voltage regulators, Voltage references, Isolation amplifiers, Phase control thyristors) were carefully tested on their radiation tolerance from 1999 onwards.

Considerable efforts were need to qualify the electronic for the Local Quench Detection (1 per MB, 2 per MQ, 2100 in total in the LHC) which is based on a Wheatstone bridge formed with the two apertures / coils and balancing resistors. The detector parts are based on analogue circuitry while the DAQ part is based on a microcontroller and a WorldFIP Interface. In 2002, sufficient information had been accumulated to state that the installation of quench protection electronics would be feasible [30]. Radiation testing on pre-series and series

production continued in 2003 and this confirmed that the quench protection electronics was successfully designed and qualified to operate at the radiation levels foreseen for in the LHC.

The **Beam Loss Monitoring system** is using some electronics in the tunnel to convert the variations of the current from the ionisation chambers to a frequency. An FPGA is used for the encoding and multiplexing while the signals are transmitted over optical fibres using laser diodes. The components on the BLMECF card were kept to a strict minimum and some radiation hardened (by design) parts designed and used in the LHC experiments were selected. In 2004, a basic set of components was successfully selected (FPGA, GOL/GOH, ADC Level converter, Current to frequency integrator (OPA627)) [31]. The tunnel card was produced in series [32] and eventually successfully tested under radiation in, amongst others, the CNGS test facility at CERN [33].

The selection of components for the **Beam Position Monitoring system** started also in a very early stage. The systems consist of 64 crates each equipped with power supplies, a Wide Band Time Normaliser (WBTN) card and a calibration board.

First focus was on the power supplies and on Front End WBTN card [34]. Linear power supplies were chosen to avoid SEB effects which proved to be successful. The WBTN board has a minimum of logic and therefore already showed good radiation tolerance in an early stage. The calibration card is used for communication via WorldFIP and has logic on it. By choosing the same parts that are used in the instrumentation electronics, the soft error rate was reduced to a minimum [33].

Particular attention was given to the laser diodes and the communication by optical fibre. Displacement Damage resulting in a loss of the emitted light at 1310 nm was initially a concern. This issue was eventually solved by dedicated displacement damage test which showed that the light intensity in some laser diodes would decrease only by 10% over the lifetime of the LHC and that there was no significant variation of the jitter between adjacent light pulses [35]. In collaboration with the TS department, special radiation hard optical fibres were selected and installed in the LHC [36].

The user interfaces for the **Beam Interlock Controller** in the LHC are located at the position of the equipment and may have to operate under radiation. First efforts concentrated on the Power Supplies (Tracopower TXL-025-25S 5V, 5A, 25W) of the user interface which successfully past DD test and a SEE test. The user interface itself has some on-board logic mainly for testing and monitoring but also in the user permit path [37]. High energy protons were used to probe the user permit path in particular the optocouplers, Schmidt triggers and the small signal-relay. It was found that the particle hits in the opto-couplers can induce glitches but that these can be filtered out with a dedicated glitch filter. The design was eventually accepted but all glitch counters are constantly being monitored to provide an early warning in case of radiation induced events.

The design of **RADMON radiation monitoring** system started only in 2002 and could therefore benefit from the radiation data on the components that had been qualified by other groups. The design is using a minimum amount of on board logic and is using the WorldFIP fieldbus interface in stand-alone mode. Standard triplication techniques are used to reduce the soft error rate. The extensive calibration runs in test beams and neutron facilities allowed to make the design radiation tolerant. In 2005, a set of 4 monitors was installed in the CDF detector at Fermilab during the high luminosity runs [38]. Radiation data was collected for the period of 1 year without interruption.

The **Orbit Power Converters** followed a slightly different design methodology, which can perhaps best be described as a hybrid solution between component and system selection. A total of 752 orbit correctors are located in the LHC tunnel and each power converter consists of a powering part and a controls part which both contain many radiation sensitive components. First radiation test on the power part showed that optocouplers and auxiliary power supplies were amongst the weakest components. In 2001 a complete prototype design was exposed to radiation with encouraging results [39].

During the first radiation tests on the controls part, a high soft error rate was observed [40]. Large efforts were then undertaken to reduce the SEE rate via partial redesign and use of error correction codes. In dedicated proton beam test in 2003, these correction codes were tested and a large reduction in the soft error rate was indeed observed [41]. However, in recent complete system test in the target area of CNGS, functional interrupts from single events were still observed [42]. Further studies are therefore needed to make this issue more precise.

LHC Electronics in Underground areas

An equipment inventory was carried out in order to collect information on the instrumentation of the LHC alcoves. The results of this survey are attached as an annex to this paper.

According to the FLUKA simulation results, the analysis was focused on the equipment installed in the most critical areas in terms of radiation, which are the UJ76, US85, UJ56, RR53, RR57, UJ14, RR13, RR17. The inventory aimed at classifying the equipments by taking into account their criticality for the LHC safety and operations and their radiation tolerant features. Four categories were established and are resumed in order of priority: 1) safety of the personnel, 2) safety for the machine, 3) downtime for the machine operation, 4) monitoring for the machine. Since the criticality of the system itself is weighted by its radiation tolerant features, it might happen to classify equipments, which are very important for the LHC operations, in the category 4. This is the case of the WorldFip repeaters (see Annex): the equipment is crucial for many critical systems but it has

priority 4 since it was proved that the equipment is radiation tolerant by means of dedicated tests.

A web survey was launched to make the inventory of the equipment. The owner of a given *equipment A* must specify the device location and its rack name, its function, its failure consequences, the results of any eventual radiation test that was done in the past, the systems on which *A* depends, the systems that depend on *A*, and its needs in terms of infrastructure (power supply, remote communication bus, cooling and so on).

The classification and the description of the equipments allow identifying the most suitable mitigation techniques, which are relocation, shielding, and radiation tolerant redesign.

In most cases, for a given equipment, there is not any significant difference among the racks installed in different areas. Therefore, it was decided to group the equipments on the basis of their function (see Annex). They are sorted according to the above-said priority classification, and, for each of them, the location, the radiation tests, the failure consequences, and the proposed mitigation techniques are resumed.

This work is still on going and may require other interactions with the equipment owners. Further updates of the equipment inventory will be published in [43].

CONCLUDING REMARKS

Radiation hardness studies on accelerator electronics have been going on for almost 12 years now and the large majority (80%) of the efforts have concentrated on the reduction of the Single Event Error rate in equipment in the LHC. Most of these concern (recoverable) soft SEEs which cause data corruption, a minor part of these efforts is directed toward (non-recoverable) hard SEEs which cause permanent loss of the data and sometimes even the circuit.

The current radiation hardness policy for single events is based on a simple Sensitive Volume model. The model allows predicting the error rate in the various particle radiation spectra that are produced in and around the LHC with a single parameter which is the hadron flux with an energy threshold of 20 MeV ($h > 20$ MeV). This number has been used extensively for the engineering and integration of equipment in the LHC construction phase. The models also predicts that for the generation of electronic parts on which the LHC equipment is based, high energy proton beam testing ($p > 20$ MeV) is representative for soft error studies while for hard single events, higher energy proton beams are preferable. Under specific circumstances, a complete system test in a complex radiation field may be envisaged.

Almost all equipment in the LHC machine relies on systems that are based on commercial parts which are not designed to be radiation hard and this automatically implies an increase of the associated risk. Radiation testing in calibrated facilities along well defined, internationally accepted standards is required to reduce the risk to a minimum. Furthermore, strict QA and lot

acceptance tests are needed to ensure that any changes in the manufacturing process of the parts are correctly accounted for.

The highest success rate in radiation tolerant designing has been obtained when the amount of components in design is minimised and the parts are carefully selected on their radiation tolerance. This requires a considerable amount of effort and resources from the equipment groups because each prototype needs at least satisfactory proton beam test results and this is often obtained via trial and error of a variety of commercial parts. In combination with soft error correction techniques and QA for series production and spares the risk associated with radiation induced errors can be brought back to an acceptable minimum and satisfactory performance can be assured over a period of several years. The majority of the main distributed control systems in the LHC tunnel have used this approach and the risk of radiation damage in these systems can perhaps best be described to be "as low as reasonable achievable".

For some LHC equipment groups it was not possible to follow this design procedure since they do not have in house design capacity and use commercial contracts instead. Some decided to verify the radiation tolerance of complete industrial systems but the success rate has been extremely limited. Industrial products were eventually selected in some particular cases, mainly when the equipment does not make use of semiconductor electronics for controls and signal processing.

Cumulative radiation damage effects have been studied in detail for systems that will be exposed to a high radiation dose and are located, for example, in the LHC cleaning areas, the LSS or the experimental caverns. For Total Dose damage studies, experiments were conducted as much as possible in line with international radiation test standards using a calibrated ^{60}Co source. However, in some cases, only proton data was available. Displacement studies were carried out with a fission reactor producing low energetic neutrons with an average energy of 0.9 MeV. Again, the focus was primarily on systems that make use of particular sensitive parts such as optoelectronics or bipolar devices.

In conclusion, the main distributed electronic systems for the LHC tunnel have a radiation hardness which is 'as good as reasonable achievable' keeping in mind that all systems use commercial (non radiation hard) parts and that statistical uncertainties will always remain. The possibility of radiation damage in the first operational period of LHC operation in these custom designed systems is low. In addition, sufficient experience with radiation tolerant designing and radiation testing is available in the equipment groups to react on a short timescale if needed.

Despite extensive efforts from various groups, very few standard commercial systems have been qualified to operate reliably in a radiation environment without any modification. By minimising the amount of equipment under radiation, the error can be reduced but never eliminated. In addition, strict QA is required since there is

no control over the manufacturing process and large variations in the radiation tolerance of different production batches are very common. Much better results are usually obtained when the controls logic and signal processing is detached and relocated in area without radiation and this solution may be an option for the equipment under radiation in the LHC underground areas (see annex).

ACKNOWLEDGEMENTS

The radiation tolerance studies would not have been possible without the continuing support for the Radio Protection (RP) Group at CERN. In 1998, the RP group made available the TCC2 target area for electronics testing and carried out detailed Monte Carlo studies of the environment. Specific ionisation chambers were installed to measure the prompt dose rate close to the equipment. RADWG members were provided with dedicated high level dosimeters and dedicated personal dosimetry for experiments outside CERN.

One of the authors (TW) would like to acknowledge F. Faccio for useful discussions on the subject.

REFERENCES

- [1] D.R. Alexander, "Design Issues for Radiation Tolerant Microcircuits for Space", Short Course presented at the 1996 NSREC conference, Indian Wells, Ca, July 15-19, 1996.
- [2] P. Jarron et al., "Deep Submicron CMOS Technologies for the LHC Experiment, presented at the 6th International Conference on Advanced Technology and Particles Physics, October 5-9, 1998, Villa Olmo, Como, Italy.
- [3] M. Campbell et al., "A Pixel Readout Chip for 10-30 Mrad in Standard 0.25 μm CMOS", presented at the IEEE NSS Conference, Toronto, Canada, November 1998, to be published on IEEE Trans. Nucl. Science.
- [4] K.Potter, H. Schonbacher, G. Stevenson, "Estimates of Dose to Components in the Arcs of the LHC due to Beam-Loss and Beam-Gas Interactions", LHC project note 18, November 1995.
- [5] H. Schönbacher, LHC machine-radiation doses and radiation damage, LHC technical seminar, November 1995.
- [6] R.A. Weller, RADECS short course, Brugge, Belgium 2009.
- [7] F. Faccio, M. Huhtinen, Nuclear Instruments and Methods in Physics Research A 450 (2000) 155 – 172.
- [8] Baumann *et al*, IEEE Proc ICRPS, pp297-302 1995.

- [9] Baumann (Texas Instruments), "Soft Error Characterization and Modeling Methodologies at TI" 2000
http://www.sematech.org/meetings/20001030/20_SE_R_Baumann.pdf
- [10] Cataldo, "IBM moves to protect DRAM from cosmic invaders" EETimes, 10 June 1998
<http://www.eetimes.com/news/98/1012news/ibm.html>
- [11] Cataldo, "MoSys, iRoC target IC error protection" EETimes, 6 February 2002
<http://www.eetimes.com/story/OEG20020206S0026>
- [12] Cataldo, "SRAM soft errors cause hard network problems" EETimes, 17 August 2001
<http://www.eetimes.com/story/OEG20010817S0073>
- [13] ChipCenter Networking Product Review, "DRAM-CAM – MOSAID's 9 Mbit DRAM-Based Chip" 28 January 2002.
- [14] L. Scheick, JPL short course on radiation effects.
- [15] C. Fynbo, G. Stevenson, LHC-PROJECT-NOTE-235, Geneva : CERN, 2000.
- [16] A. Jaksic, 'Proton and Gamma Irradiation Response of NMRC Radfets' D/TOS-QCA Final Presentation Day 2002, ESA/ESTEC Nordwijk.
- [17] A. Presland, T. Wijnands, LHC-Project-Note-351; CERN-LHC-Project-Note-351, Geneva, CERN, 2004.
- [18] P. Beynel, P. Maier, H. Schonbacher, 'Compilation of radiation Damage Test Data', part I, II, III'. CERN, Geneva 1982.
- [19] <https://escies.org/GetFile?rsrcid=3081>
- [20] <https://escies.org/GetFile?rsrcid=760>
- [21] G. Berger, 6th LHC radiation day, CERN 2007
- [22] W. Hajdas, 6th LHC radiation day, CERN 2007
- [23] Y. Calzavara, N. Authier, S. Wisnieski, X. Jacquet, RADECS conference, Cap D'agde, September 2005.
- [24] <http://indico.cern.ch/categoryDisplay.py?categId=414>
- [25] P. Dahlen, 6th LHC radiation day, CERN 2007.
- [26] M. Rodriguez, 1st LHC radiation day, CERN 2001.
- [27] J. Casas-Cubillos, F. Faccio, P. Gomes, M.A. Martín, M.A. Rodríguez Ruiz. "SEU tests performed on the digital communication system for LHC cryogenic instrumentation", Nuclear Instruments & Methods in Physics Research. NIMA A 485 (2002) 439-443. Elsevier Science.
- [28] E. Gousiou *et al.*, TWEPP09 Topical Workshop on electronics for particles physics, Paris 2009.
- [29] R. Denz, 1st LHC radiation day, CERN 2001.
- [30] R. Denz, 2nd LHC radiation day, CERN 2002.
- [31] B. Dehning, 4th LHC radiation day, CERN 2004.
- [32] E. Effinger *et al.*, 12th Workshop on electronics for LHC and future experiments, Valencia, Spain 2006.
- [33] D. Kramer, this conference.
- [34] E. Calvo Giraldo, 1st LHC radiation day, CERN 2001.
- [35] T. Wijnands, 4th LHC radiation day, CERN 2004.
- [36] T. Wijnands *et al.*, IEEE Trans Nucl Sc., Vol. 55, No. 4, August 2008
- [37] B. Todd *et al.*, 7th LHC radiation day, CERN 2007.
- [38] T. Wijnands, 74th LEMIC meeting, 14 June 2005.
- [39] D. Nisbet, 1st LHC radiation day, CERN 2001.
- [40] J. Pett, 1st LHC radiation day, CERN 2001.
- [41] Q. King *et al.*, <http://cdsweb.cern.ch/record/702772/>.
- [42] Y. Thurel, this conference.
- [43] <http://r2e.web.cern.ch/R2E/>

Equipment	Location	Description	Radiation test	Failure consequences	Option
Fire/ODH control	UJ76 US85 Uj56 I.0 Safe room	Control system (PC based)	No	No fire detection, no ODH detection Failure affects also the areas UJ US UX RE	Relocation
Fire/ODH detectors	UJ87/23 UJ561.1 (detectors) UJ14/16 RR53/57 RR13/17	Detectors (PC based)	Yes - CNGS	No fire detection; if two more detectors are in fail mode, an evacuation is triggered	Relocation
AUG control	UJ76 US85 UJ56	Logic for the AU safety based mechanical relays Some commercial ICs	No	Loss of the AUG logic	Relocation
UPS	UJ76 US85 UJ56	Microprocessor-based and power solid state switch	Sensitive	Loss of Cryogenics, vacuum, QPS, Beam monitoring.	Relocation
Electrical equipment	UJ76 US85 UJ56 I.0 UJ14 RR53/57 RR13/17	Electrical distribution Control and monitor equipments (not in UJ14/16, RRs) 48 Vdc/24 Vdc generation and distribution. Safety lighting and its powering system Commercial ICs; power solid state switch; microprocessor	No	Loss of power supply and possible loss of the safety lighting	Shielding/ Relocation
Collimation control	UJ56 I.1 UJ14/16	NI PXI controller Data acquisition card FPGA cards	Yes - CERF facility	Beam dump	Relocation
Remote-Reset & Timing	UJ76 US 85 UJ56 (I.1)	Custom design PLC and Remote IO modules	No	Loss of timing Beam dump	Relocation
QPS and Energy Extraction	UJ 56 I.1 RR53/57 UJ14/16 RR13/17	High level controls	Yes -CNGS facility Protons 60 MeV	Prohibited re-powering Possible fast power abort sequence No protection for the magnets (rare)	Redesign, or partial relocation
Power Converter	UJ76 UJ56 I.1 RR53/57, I.0/1 UJ14/16 I.1 RR13/17, I.0/1 UJ23 UJ87	FGC DCCT Controls power part	Yes -CNGS facility	Beam dump	Relocation Partial redesign Shielding SC link
Vacuum	UJ76	Read out of sensors PLC, I/O module	No	Beam dump	Relocation
Access System Control	UJ76 UJ 56 I.1	Control equipment switches	No- Controls 60 Co for switches	Misbehave could generate alarms and stop of the machine	Relocation
Ethernet	US85 UJ56 (I.1)	Ethernet Switches	No	Loss of the Ethernet connection for the clients	Relocation
Cooling and Ventilation	UW85, UA87 UJ76 UJ56,RR57 UA23	PLC, remote I/O	No	No CV for Equipment and the experiments Possible operational stop	Shieldin/ Relocation
Cryogenics Refrigerators and Valve Positioners	US85 UX85	PLC, Remote I/O CCS rack	No	No control of cryogenics for SC magnets	Relocation
Cryogenics Instrumentation and Electronics (PROFI bus)	UJ76 UJ56 I.1 RR53/57 UJ14/16 RR13/17	Remote I/O Valve Positioners (UJs) Embedded electronics on sensors Actuators	TCC2 facility	No input for Cryogenic system that could drive a beam dump	Relocation
WIC	US85	PLC Siemens and Remote I/O	No	No control for warm magnets Beam dump	Relocation
Power Interlock	UJ56 I.1 UJ14/16	PLC	No	Beam dump Users: Power converters, QPS, BIC, Cryogenics, UPS, AUG	Relocate
Power Interlock	RR57/53 RR13/17	Remote I/O ANYBUS cards with CPLDs(5 V)	Yes – TCC2 facility 60 MeV p CNGS facility	Beam dump Users: Power converters, QPS, BIC, Cryogenics, UPS, AUG	ok for RRs
Beam Interlock	UJ56 I.1	VME crate CIBU on the user side. FMCM	Yes – CNGS, 60 MeV p, 250 MeV p, Heavy Ion, 1 MeV n	Beam dump Users: Vacuum, Collimation, PIC, CMS and Totem Exp.	Relocation of control part (VME rack) to be verified
RAMSES	UJ76	PC based	No	Delay in the intervention	Relocation
Access	UJ14/16 UJ23	PC based	No	Misbehave could generate alarms and stop of the machine	Relocation/ Switch the system

System Gates	UJ87			Delay in the intervention	off during operation
Beam Television Monitor	UJ76	VME controller CES RIO 4 (temporary)	No	Loss of the monitor. Operation only in Inject and dump mode	Relocation
Current Leads Heaters	UJ56 I.1 RR53/57 RR13/17 UJ14/16	Regulators and solid state relays	Yes - CNGS	No heating of the top part of the current lead. Pose an issue only for the machine restart	Relocation
Survey	US85 UX85b UJ56 I.1 UPS54/56 UPS14/16	Electronic for sensors in US85(door) UX85, and UPS56/54 Data acquisition and control motor system (UJ56, UA83)	Yes – CNGS, 60 MeV p, n 180 MeV, n 1 MeV, TID 60 Co Motor driver - not tested	No alignment for low beta magnets. Issue for operation	Stay as is
GSM Repeaters	US85 safe room UJ56 safe room UJ76	GSM probe	No	Loss of the GSM service in the tunnel	Shielding Relocation
Beam Position Monitors	UJ56 I.1 RR53 RR57 UJ14/16 RR13/17	Power supply card Microfip Intensity car WBTN analog	Yes – TCC2, CNGS, p 60 MeV	Possible degradation of the beam orbit reading	Stay as is Possible redesign intensity card.
Beam Loss Monitor	UJ76 (temporary) RR53/57 RR13/17	Custom electronics	Radiation tolerant	No machine tuning Beam dump	Stay as is
Optical Fiber	US85 UJ56 I.1	Patch panels	Yes 60Co	Radiation induces attenuation of light	Relocate if required by Ethernet switches
AUG Buttons	LHC underground	Mechanical button	Plastic component deteriorated by radiation but already under control	Loss of full functionality	Stay as is Radiation test materials
Cryogenics Instrumentation and Electronics (FIP bus)	RR77 UJ56 I.1 RR53/57 UJ14/16 RR13/17	RadTol ASICS Antifuse FPGA Data acquisition systems Fip bus	Yes - CNGS	No input for Cryogenic system that could drive a beam dump	Stay as is
WorldFip	US85 UX85 UJ56 I.1 RR53/57 UJ14/16 RR13/17	Cu/Cu repeaters FipDiag Optical repeaters	Yes - CNGS	Repeater: loss of the network for the next users FipDiag: Loss of the network diagnostic	Stay as is Depend on the clients Power converter, Radmon, Experiment Survey, Cryogenics QPS

Annex: Equipment inventory. Red: priority 1; Yellow: priority 2; Blue: priority 3; Green: priority 4.