

MASS STORAGE MANAGEMENT AND THE GRID

A. Earl and P. Clark, University of Edinburgh

Abstract

The University of Edinburgh has a significant interest in mass storage systems as it is one of the core groups tasked with the roll out of storage software for the UK's particle physics grid, GridPP. We present the results of a development project to provide software interfaces between the SDSC Storage Resource Broker, the EU Data-Grid and the Storage Resource Manager. This project was undertaken in association with the eDikt group at the National eScience Centre, the Universities of Bristol and Glasgow, Rutherford Appleton Laboratory and the San Diego Supercomputing Center.

Introduction

This poster presents the background and current status of the SRM2SRB project. This project is an attempt to address the need to provide a Storage Resource Manager (SRM) compliant interface to existing distributed data storage solutions, specifically the Storage Resource Broker (SRB) from SDSC. SRM is fast becoming the de facto standard for providing access to data storage facilities on the Grid and as such, the work which has been conducted by other groups in the past few years will be negated, unless there is a way of providing an SRM interface into them.

Existing software

The SDSC Storage Resource Broker (SRB) provides access to multiple data systems including file systems, databases and mass storage systems. Metadata on resources, data, and users, is contained in a central relational database called the Metadata Catalog or MCAT, shown in Figure 1. SRB has been in use at various sites in the UK since the start of the e-Science programme in 2001 and UK sites have developed expertise in it and have forged strong links with the development team.

The Storage Resource Manager is a community based standard for providing Grid access to data resources. While there are several implementations of the standard in existence now, there is no single group which is responsible for its development and deployment. This offers the advantage of wide support for the protocol but has the disadvantage that incompatibilities may exist between different implementations. Metadata in SRM is left to the individual developers and groups to deal with to allow optimisation for the problem being addressed.

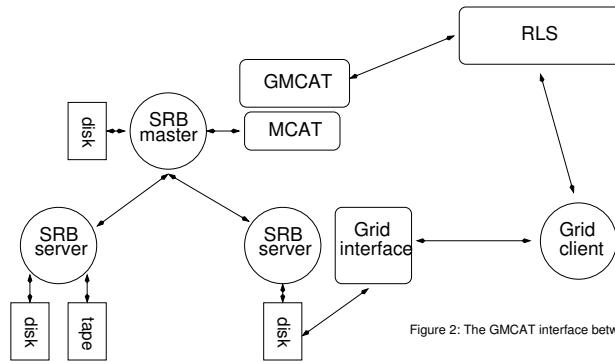

Figure 2: The GMCAT interface between SRB and RLS

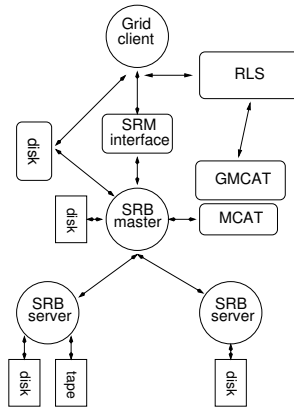

Figure 3: An SRM interface to SRB

GMCAT – A step forward

The GMCAT project was developed at the University of Bristol as a proof-of-concept project which would provide information about files stored in SRB to the European DataGrid's Replica Location Service (RLS). This is demonstrated in Figure 2 where GMCAT scans the MCAT for new and modified files and maps this information into an appropriate format to update the RLS. This is an interesting solution to the problem of locating data in different storage solutions but does not deal with the problem of retrieving it.

This issue is of interest to Edinburgh as we intend to provide data storage facilities as part of the ScotGrid regional computing for a variety of groups. These groups will typically have preferred data management systems which we need to ensure are interoperable and do not conflict with each other.

SRM-to-SRB

The SRM2SRB project is currently in the process of developing an interface to SRB which will allow users to access their data through multiple platforms. This will give users and storage providers the ability to migrate their metadata systems as needed. Edinburgh has several students and researchers working on this at the moment.

The main issues we are currently addressing are: accessing replicated data in the SRB repository and accessing data through multiple accounts. These problems are of great significance to the Grid community as the file security paradigms which have been used in the past are no longer available to us. Users are now identified by their Grid Certificate rather than their UNIX User ID which creates complications at the operating system layer.

We have identified several different methods which could be used to achieve access to SRB stored data including an interface at the SRB Master node and on each SRB Server. We are currently investigating both options to discover the performance trade offs each solution offers and the issues raised in terms of maintaining data consistency by separately managed metadata systems.

The project is currently focused on adapting the Tape Storage Manager (TSM) software in the Berkeley Hierarchical Storage Manager (HSM) package. This will allow us to treat SRB as a standard tape system and cache data from it to disk before transferring it to the user. The obvious performance disadvantage of this solution is currently being addressed.

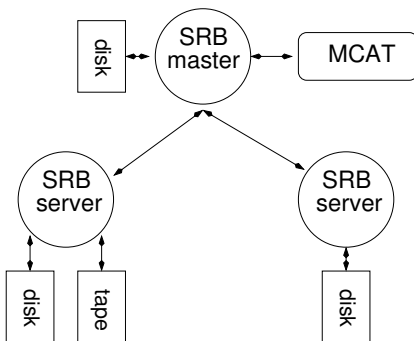

Figure 1: A logical depiction of the SRB system

Conclusions and Future Plans

The SRM2SRB project has shown that there is interest in ensuring that the development work which has been conducted by various groups over the past three years is not lost as new and emerging standards appear. SRM is gaining popularity as an interface to resources but does not match the functionality which the SRB system currently has deployed. Our plans for the SRM2SRB project are to move it past its current development phase and into production use at various sites.

Acknowledgements

We would like to thank the UK Particle Physics and Astronomy Research Council (PPARC) for funding studentship PPA/S/E/2001/00238 and the GridPP collaboration. The ScotGrid equipment used for this paper was funded by the Scottish Higher Education Funding Council (SHEFC).

References and Links

SDSC Storage Resource Broker
<http://www.sgi.com/SDSC/SRB/>
 GGF Grid Storage Management Working Group
<https://forge.gridforum.org/projects/gsm-wg/>
 SRM2SRB Mailing List
<http://www.jiscmail.ac.uk/lists/SRM-FOR-SRB.html>