

CARBON NANOMATERIALS APPLICATION FOR ISOL-METHOD OF HEAVY ION FUSION REACTION PRODUCTS

**Joint Institute for Nuclear Research
Flerov Laboratory of Nuclear Reactions**

Presenter: Viacheslav Vedeneev

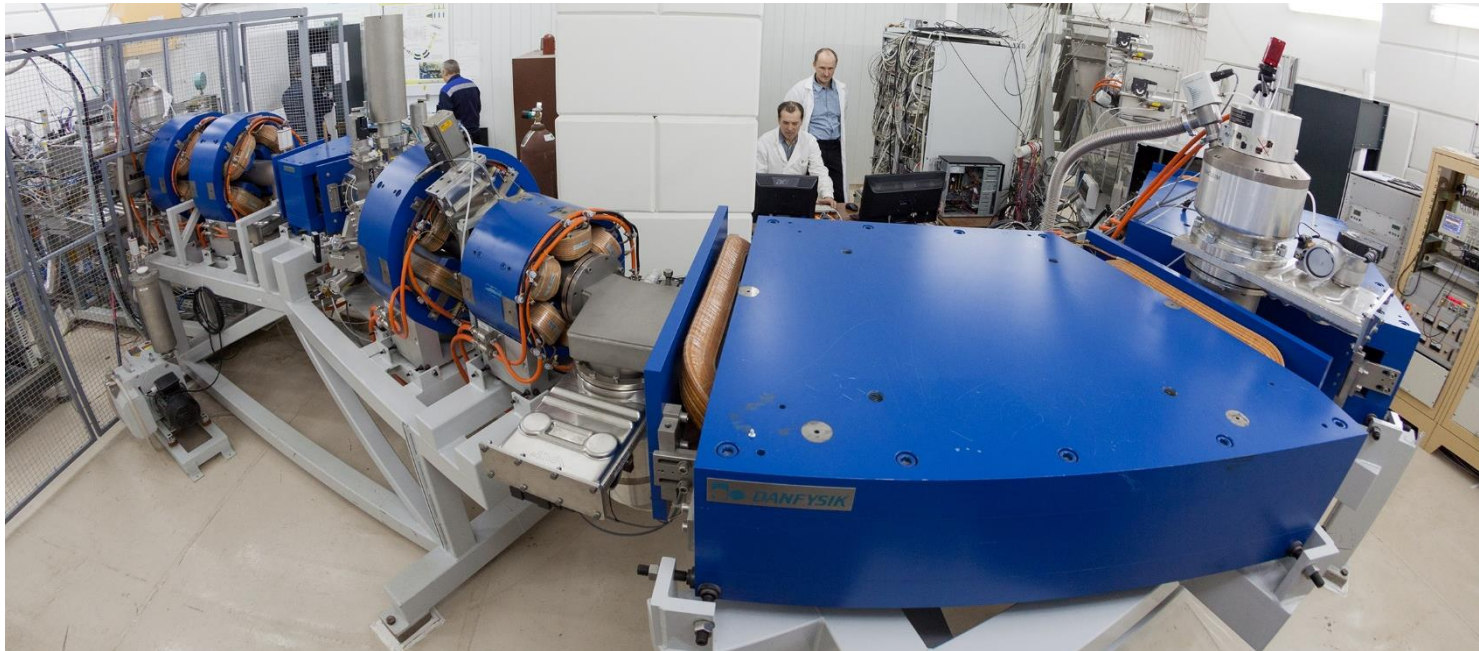

Separation of heavy ion fusion reaction products

Catchers: Solid

Liquid

Gas

Main requirements:

1. Enough separation efficiency;
2. Separation time – in order of SHE isotopes lifetime.

Catcher material characteristics:

1. High temperature stability ($D=D_0 \cdot \exp(-Q/RT)$).
 D_0 – diffusion factor, Q – activation energy.
2. High porosity.
Porous graphite – polygraphene

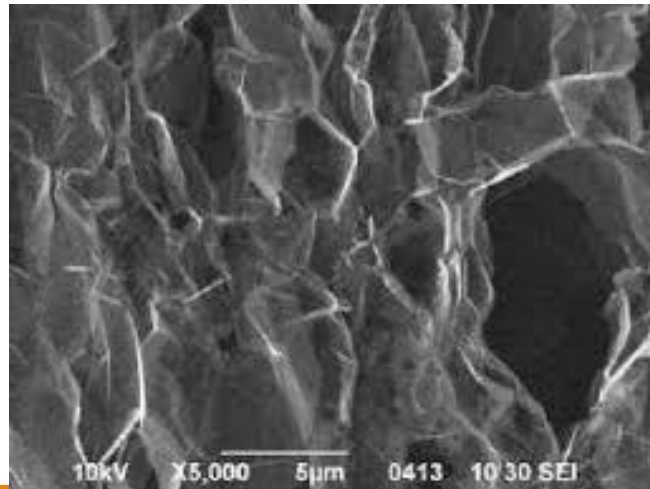

Solid ISOL method application for Superheavy nuclei mass measurements

1. Two well-known volatile superheavy elements: Cn (Z=112) and Fl (Z=114).
2. Some isotopes have long enough decay time:
 $^{283}\text{Cn} - 3.8 \text{ s}$, $^{285}\text{Cn} - 29 \text{ s}$, $^{289}\text{Fl} - 2.6 \text{ s}$.

Favorable reactions: $^{242, 244}\text{Pu} + ^{48}\text{Ca}$

Separation time –
order of seconds

Separation efficiency
quite enough

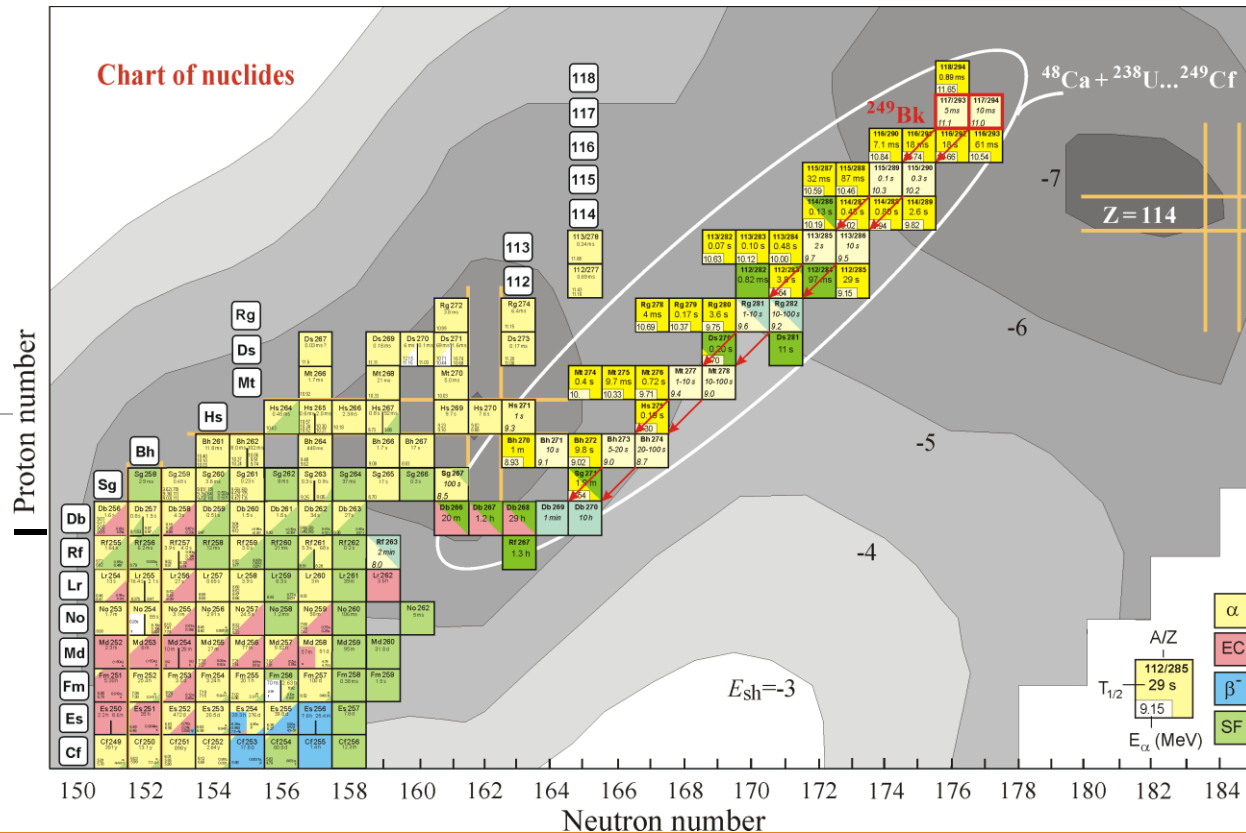

Application of ISOL method for heavy ion induced reaction

Main characteristics of ISOL systems are:

1. Separation efficiency;
2. Separation time.

Comparison of ISOL systems at ISOLDE-SC and MASHA

Setup	Catcher	Target thickness	Transport temperature	Separation time, s	Separation efficiency, %
ISOLDE-SC	Liquid lead	170 g/cm ²	≤ 1000 K	30	7.8
MASHA	Polygraphene paper	0.06 g/cm ²	293 K	1.8	0.07

MASHA: reaction $^{40}\text{Ar} + ^{144}\text{Sm}$



ISOLDE-SC: $p^+ + ^{\text{nat}}\text{Pb}$

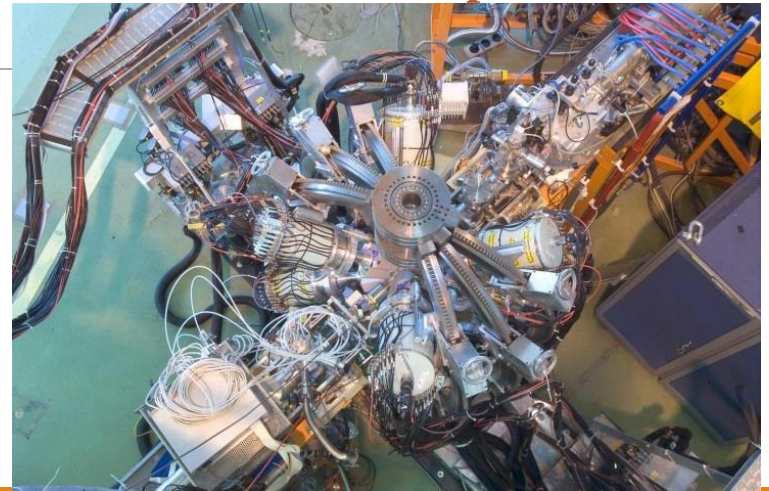

MASHA (Mass Analyser of Super Heavy Atoms)

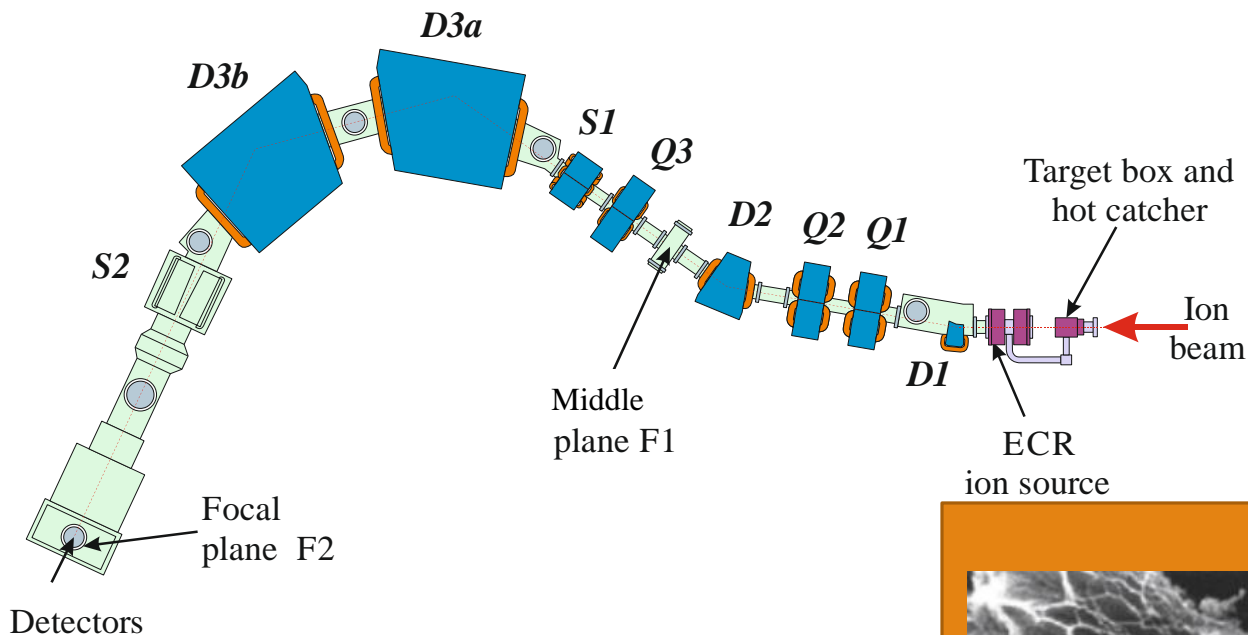

MASHA setup is a combination of ISOL method of synthesis and separation of radioactive nuclei with the classical method of magnetic mass analysis, allowing identification of the synthesized nuclides in the wide mass range ($A = 1 - 450$ a.m.u.).

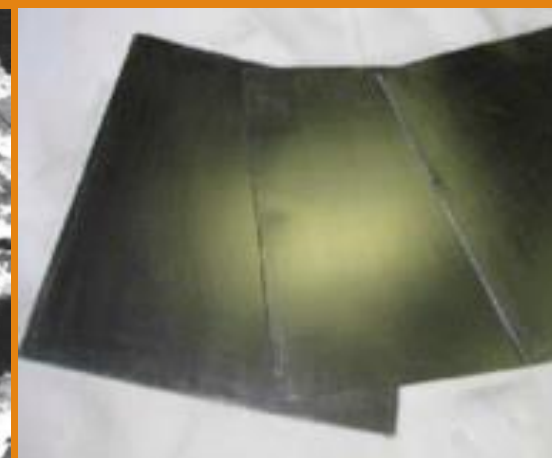
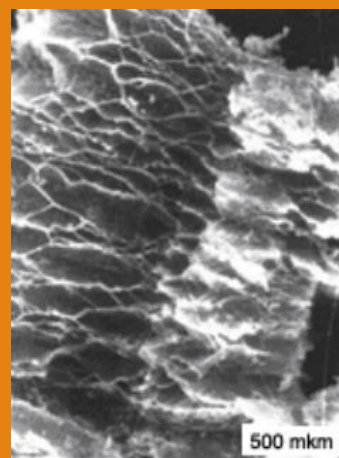

Poly-graphene paper, density of 0.5 g/cm^3 (porosity – 75%). It is possible to produce as a paperboard with thickness 0.6 mm

Operating temperature of hot catcher – 1800-2000°C.

Delivery time of nuclides to the ECR ion source ~ 1.8 s.

ECR ion source: ionization efficiency – up to 90% for noble gas.

Operation pressure – 10^{-5} mbar

Limitations of the method for experiments with heavy ion beams

First attempt of determination of mass of Cn and Fl elements as daughter products of the reaction $^{48}\text{Ca}+^{242}\text{Pu}$ (2015)

Target: ^{242}Pu (0.49 mg/cm²) with an admixture of Nd isotopes (~ 1%).

Separation efficiency of MASHA setup as a function of measurement time.

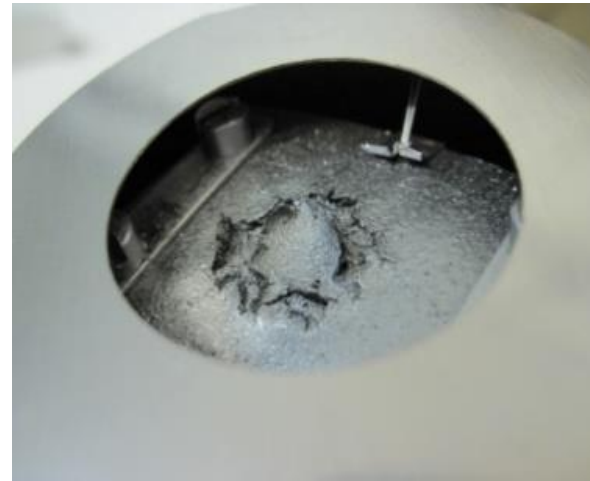
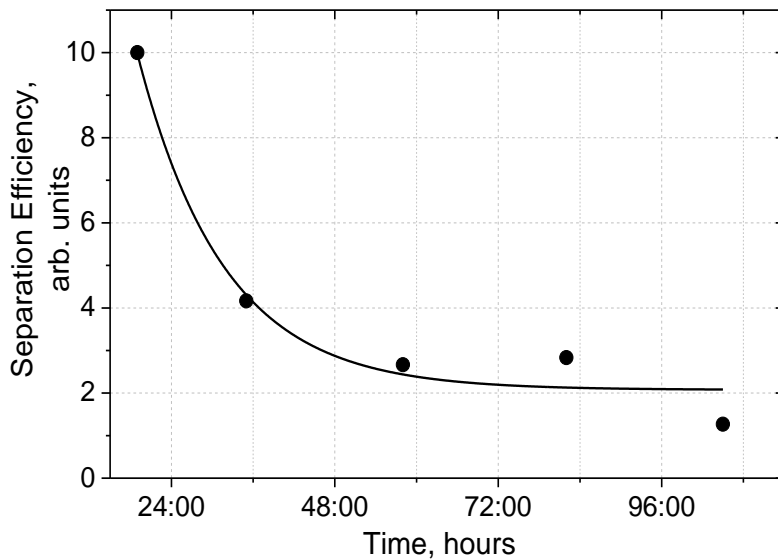

Poly-graphene paper after irradiation (300 h).
Beam current (^{48}Ca) ~ 0.5 μA .

Electrical volume power density – 2 kW/cm³

Ion irradiation power density – 8 kW/cm³
(ion beam intensity 0.5 μA)

During the experiment, a detailed study of efficiency and reliability of all systems was carried out. It was observed that the separation efficiency of MASHA setup is not stable during the experiment in the case of high beam intensity (typically 10 mA of ^{48}Ca). The high beam intensity corrupts the Hot Catcher and the separation efficiency of the Hot Catcher decreases by almost ten times during a few days.

Modernization of the MASHA setup

New design of the hot catcher: “Separated” graphite heater + catcher made of 1,1 mg/cm² graphene foil or carbon nanotube paper 6,4 mg/cm² thicknesses.

Installation of 16-strip silicon detector at the middle plane F1 (permanent control of the separation system by measurement of Hg yield).

New design ECR ion source and the vacuum chambers for ECR ion source, catcher and transport line: chemical inert covering of the inner part of the vacuum chambers; heating of the vacuum chamber at the temperature 300°C.

New materials: graphene and carbon nanotubes

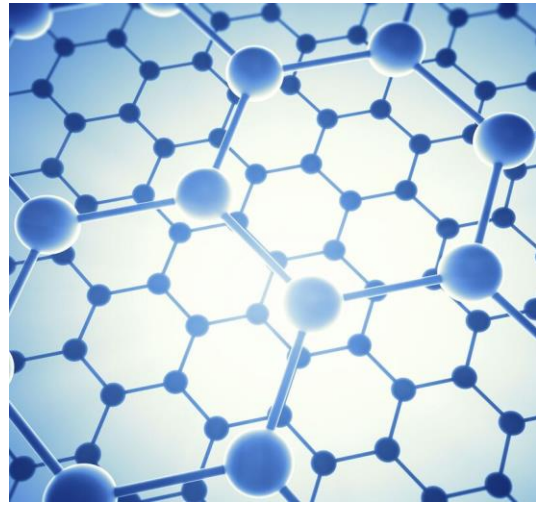

Graphene/
nanotube
paper foil

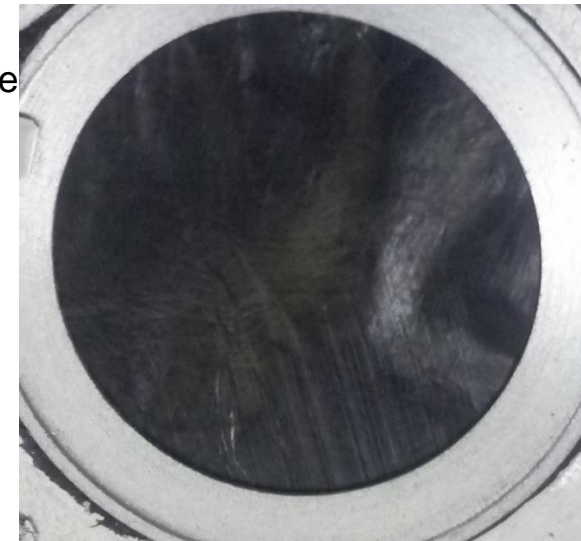
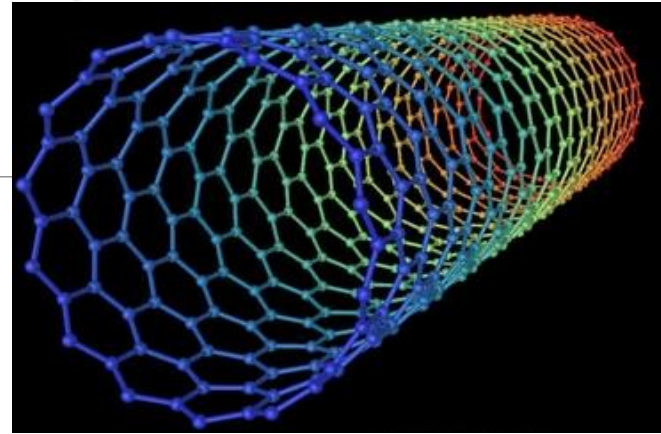
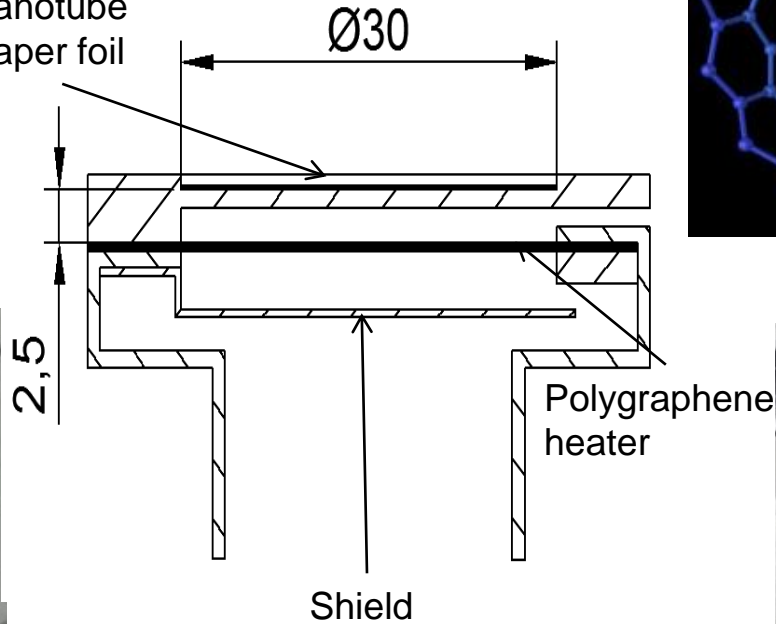

New arrangement of rotating target and separation system

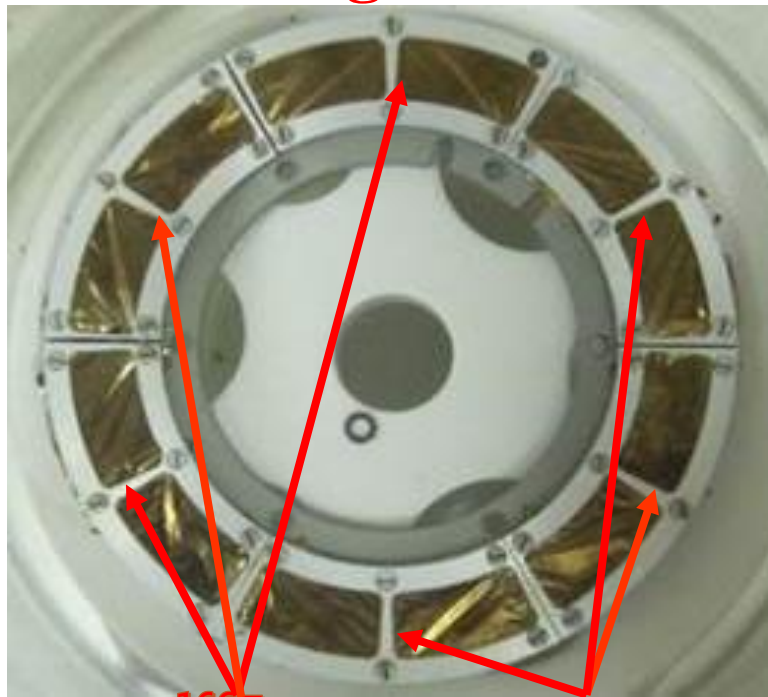

^{166}Er

(6 sectors)

^{144}Sm

(6

sectors)

Rotating target wheel

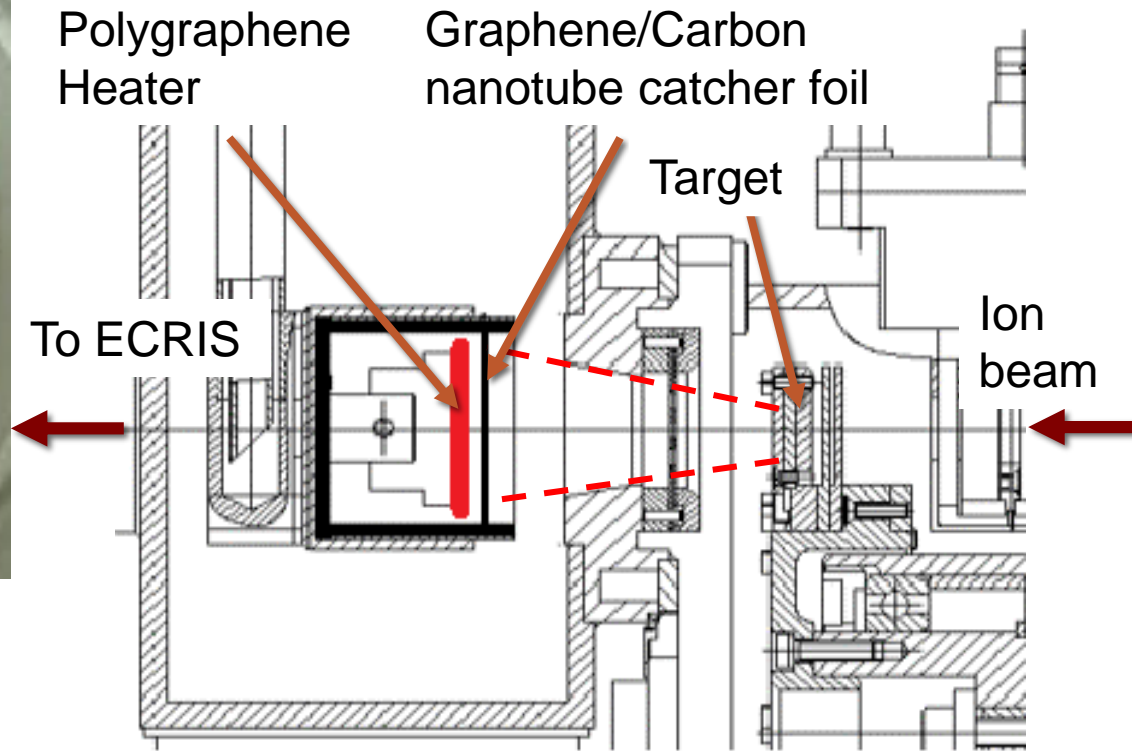

Target for test experiment: irradiation stability of the new design hot catcher and synchronous measurement of products of the reactions $^{40}\text{Ar}+^{144}\text{Sm}$ and $^{40}\text{Ar}+^{166}\text{Er}$

Strip detector at the intermediate focal plane F1 for control of the separation system

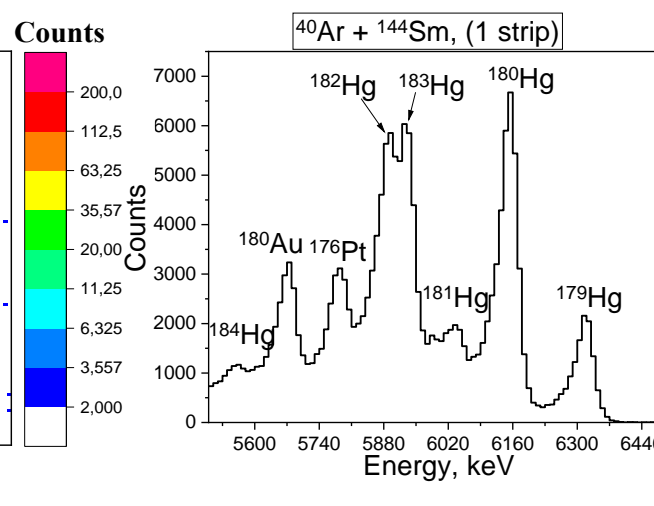
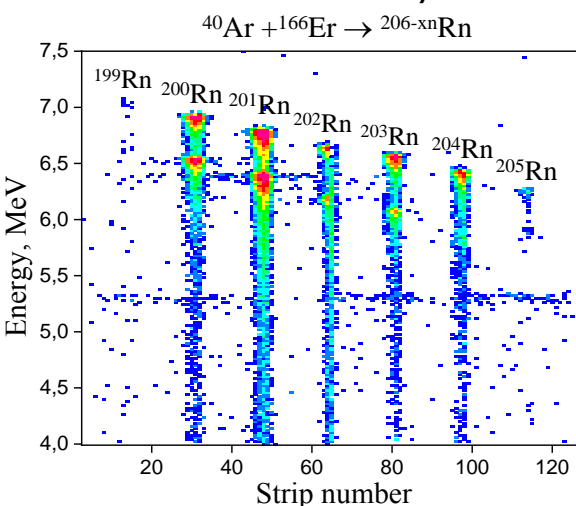
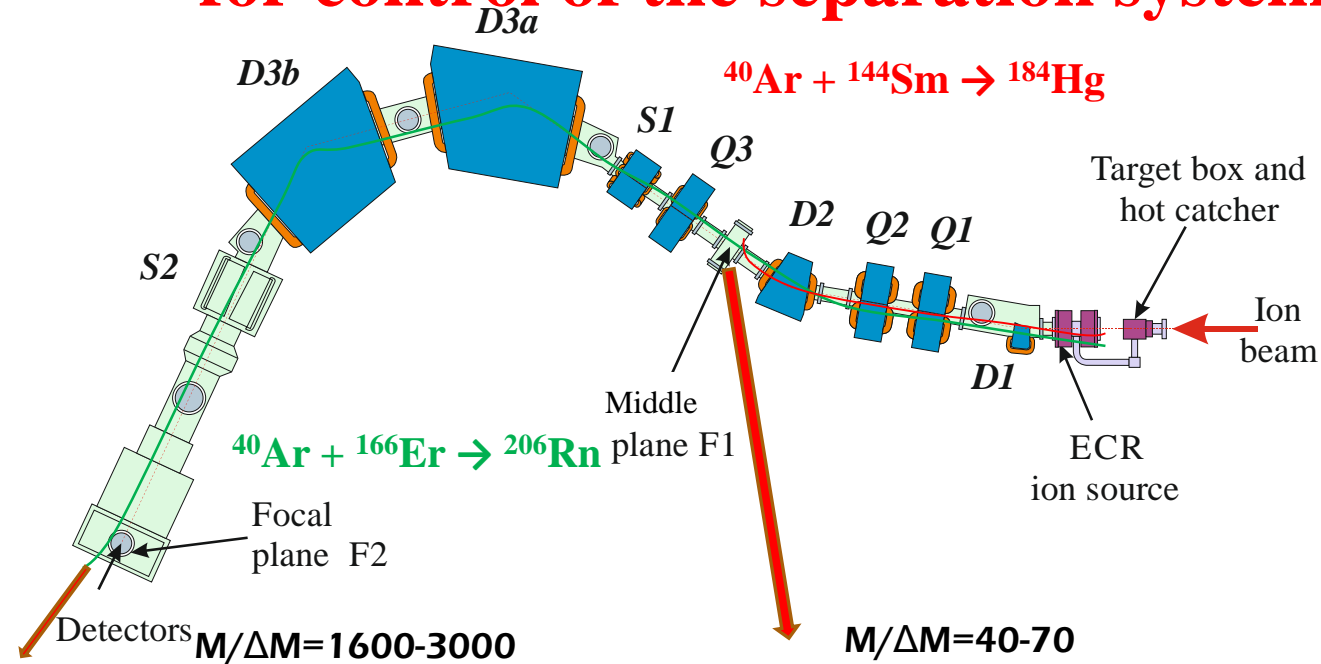

Test experiment:
 F1: $^{40}\text{Ar} + ^{144}\text{Sm} \rightarrow ^{184}\text{Hg}$
 F2: $^{40}\text{Ar} + ^{166}\text{Er} \rightarrow ^{206}\text{Rn}$

Experiment with superheavy elements:
 F1: $^{48}\text{Ca} + ^{142}\text{Nd} \rightarrow ^{184}\text{Hg}$
 F2: $^{48}\text{Ca} + ^{242}\text{Pu} \rightarrow ^{290}\text{Fl}$

Efficiency stability of the hot catcher from carbon nanotubes

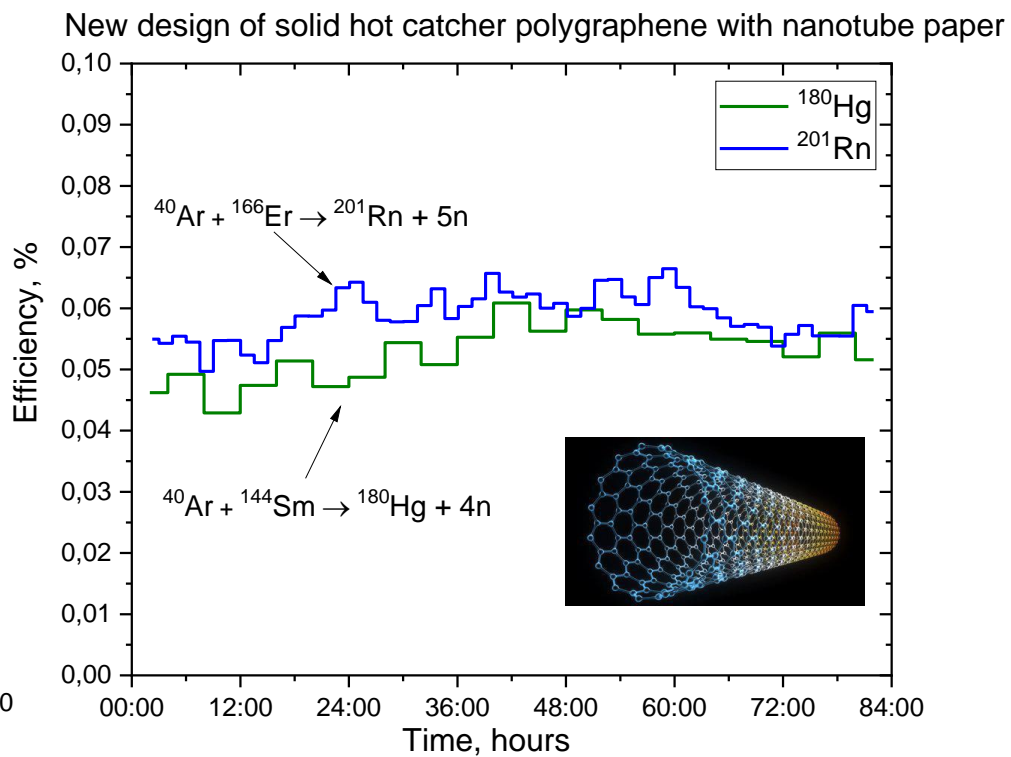
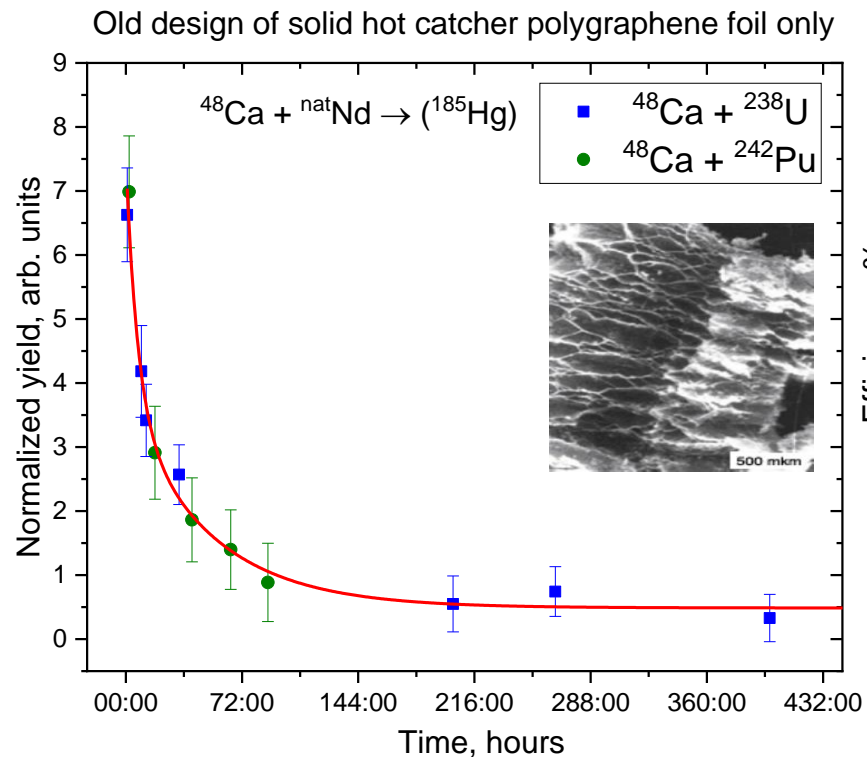

Separation efficiency of isotope ^{185}Hg as a function of time measured with polygraphene catcher in two different reactions. ^{185}Hg was measured at the middle plane of MASHA separator in the reaction ^{48}Ca with natNd admixture in both targets.

Separation efficiency of Rn and Hg isotopes as a function of time measured simultaneously with graphite nanotube catcher for beam energy in the middle of the target 218 MeV. Rn isotopes – at the focal plane (F2), Hg isotopes – at the middle plane (F1) of MASHA separator.

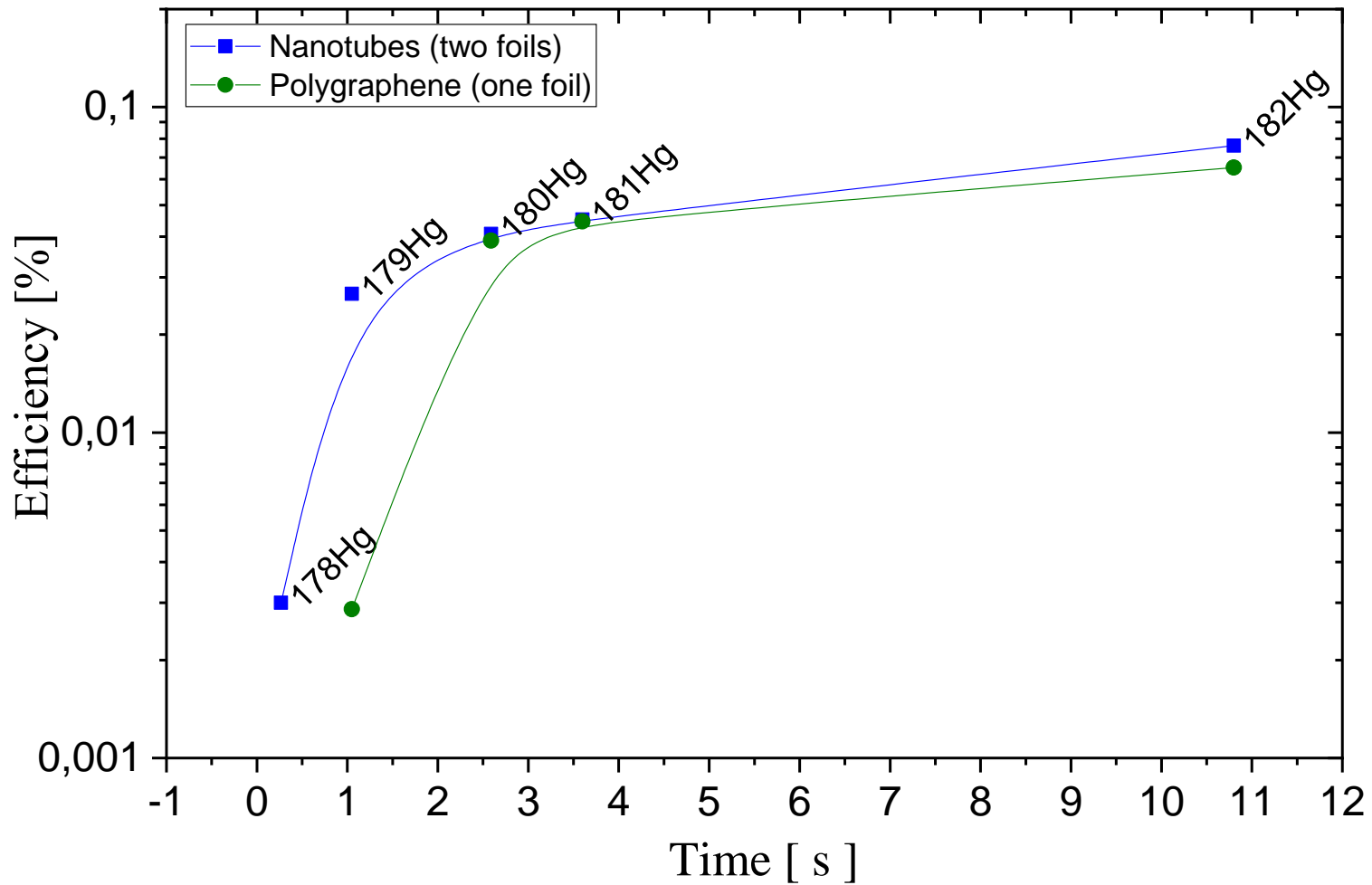

Time response of MASHA separator for two different solid hot catcher designs. Blue line – new design with nanotube paper. Green line – old design with polygraphene.

Conclusion: current status of modification of MASHA spectrometer

- New design of the hot catcher: test on the ion beam shows the perspective of the new materials
- Installation of the strip detector at the middle plane F1 gives the permanent control
- New design ECR ion source and the vacuum chambers for ECR ion source, catcher and transport line
- Chemical inert covering of the inner part of the vacuum chambers – test experiment started

Staff and the acknowledgements

A.M. Rodin, L. Krupa, E.V. Chernysheva, A.V. Gulyaev, A.V. Gulyaeva, M. Holik, J. Kliman, P. Kohout, A. Kohoutova, A.B. Komarov, A.S. Novoselov, A. Opichal, J. Pechousek, A.V. Podshibyakin, V.S. Salamatin, S.V. Stepantsov, V.Yu. Vedeneev, S.A. Yukhimchuk.

Sincere gratitude to:

- FLNR U-400M acceleration complex for a qualitative ion beam;
- FLNR engineering staff for the experiment support;
- Saint-Petersburg University and NUCLEUS-2021 for organizing the online conference;
- listeners – for your attention!