

Supported in part by

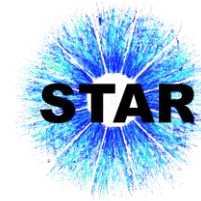

Global polarization of Ξ hyperons in Au+Au collisions in the STAR experiment

Outline:

- Introduction
- Global hyperon polarization
- Motivation
- The STAR experiment
- Hyperon polarization measurements
- Results
- Conclusions

Egor Alpatov (for the STAR Collaboration)

National Research Nuclear University MEPhI



Introduction

- The Quark-Gluon Plasma (QGP) formed in non-central nucleus-nucleus collisions is associated with large angular momentum, that leads to vorticity in the medium
- Spin-orbit coupling aligns spin directions of produced particles with the direction of vorticity
 - Z.-T. Liang and X.-N. Wang, PRL94, 102301 (2005)
 - S. A. Voloshin, arXiv:nucl-th/0410089
- Another possible source of particle polarization is magnetic field, created in non-central collisions in the initial stage
 - D. Kharzeev, L. McLerran, and H. Warringa, Nucl.Phys.A803, 227 (2008)
 - McLerran and Skokov, Nucl. Phys. A929, 184 (2014)

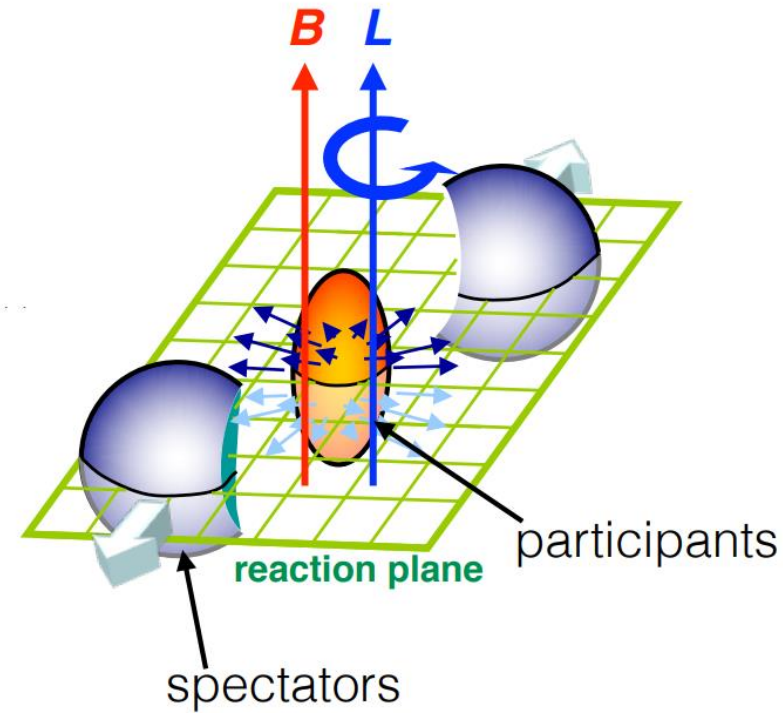

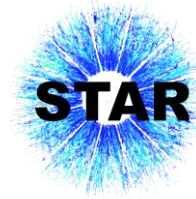

Vorticity

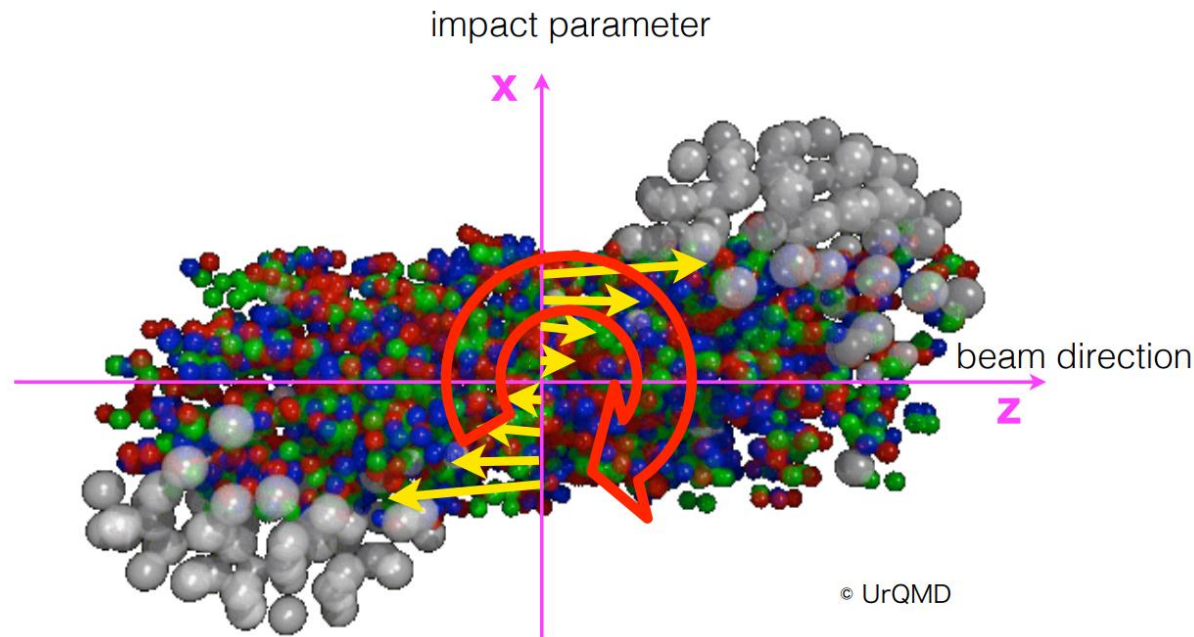

© UrQMD

- In non-central HIC the initial collective longitudinal flow velocity depends on x:

$$\omega_y = \frac{1}{2} (\nabla \times v)_y \approx -\frac{1}{2} \frac{dv_z}{dx}$$

- For small polarization:

Becattini, Karpenko, Lisa, Upsal, Voloshin PRC95.054902 (2017)

$$P_\Lambda \approx \frac{1}{2} \frac{\omega}{T} + \frac{\mu_\Lambda B}{T}$$

$$P_{\bar{\Lambda}} \approx \frac{1}{2} \frac{\omega}{T} - \frac{\mu_\Lambda B}{T}$$

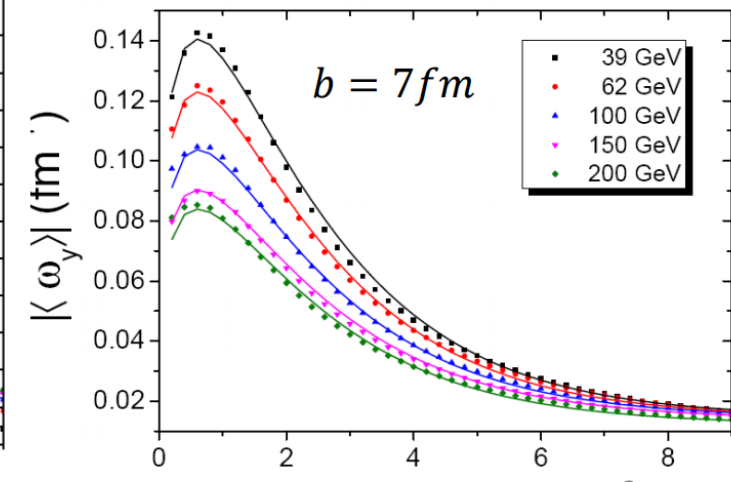
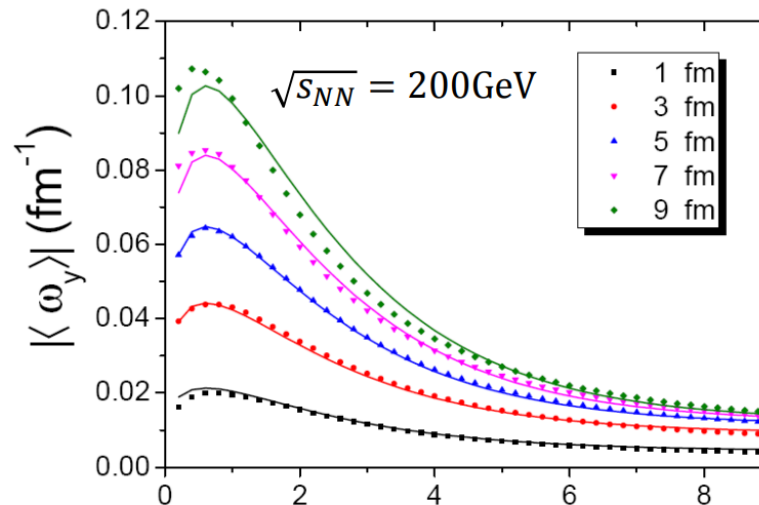

Jiang et al, PRC94 044910 (2016)

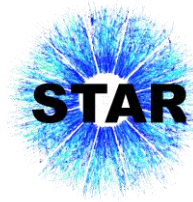

How to measure global polarization?

- Hyperons are “self-analyzing” due to weak decay properties:
 - Daughter baryons are preferentially emitted along parent spin direction
- Daughter baryons of hyperons with polarization (\vec{P}) follows the distribution:

$$\frac{dN}{d\Omega^*} = \frac{1}{4\pi} (1 + \alpha_H |\vec{P}| \cdot \widehat{\vec{p}}_b^*) = \frac{1}{4\pi} (1 + \alpha_H P \cos \theta^*)$$

- α_H - decay parameter, unique for each hyperon species
- $\widehat{\vec{p}}_b^*$ is the daughter baryon momentum in the parent frame
- Projection to the transverse plane can be measured:

$$P_H = \frac{8}{\pi \alpha_H} \frac{\langle \sin(\psi_1 - \varphi_p^*) \rangle}{Res(\psi_1)}$$

- ψ_1 is the reaction plane angle
- ψ_1 and its resolution $Res(\psi_1)$ can be calculated with spectator’s signal.
- Ξ global polarization could also be measured via its daughter Λ polarization with transfer factor $C_{\Xi\Lambda} = 0.932$

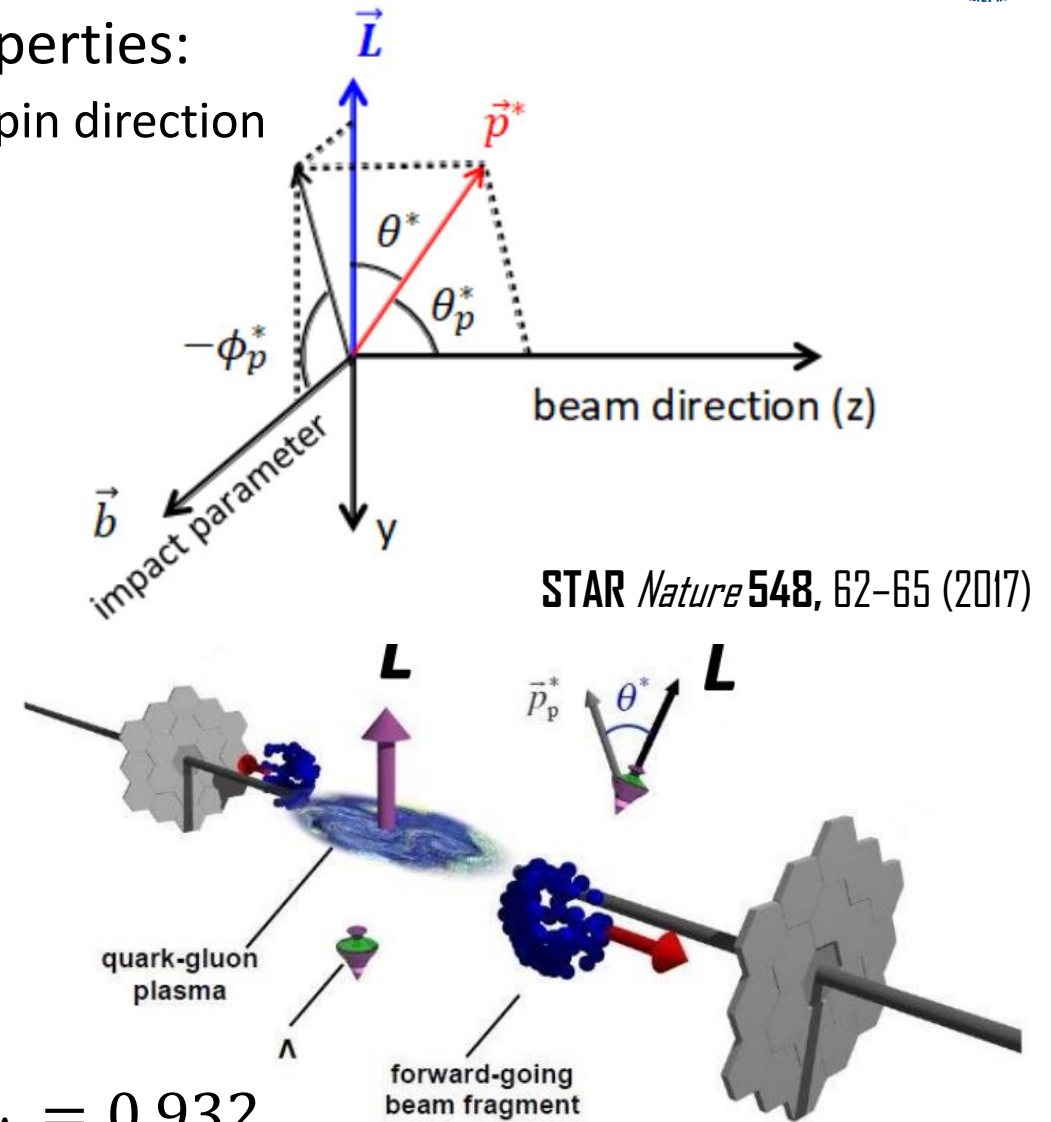



Motivation

- Global polarization of Λ hyperons was measured for $\sqrt{s_{NN}} = 7.7-200$ GeV at STAR
- P_H decreases with increasing collision energy
- Difference between P_Λ and $P_{\bar{\Lambda}}$ maybe due to B-field effect
- Theoretical calculations can quantitatively explain the energy dependence of the Λ polarization, but many of them fail to explain differential measurements
- Nowadays there is a growing interest to measure the global polarization of other hyperons such as Ξ .
- Ξ polarization may provide new input for global polarization and vorticity studies

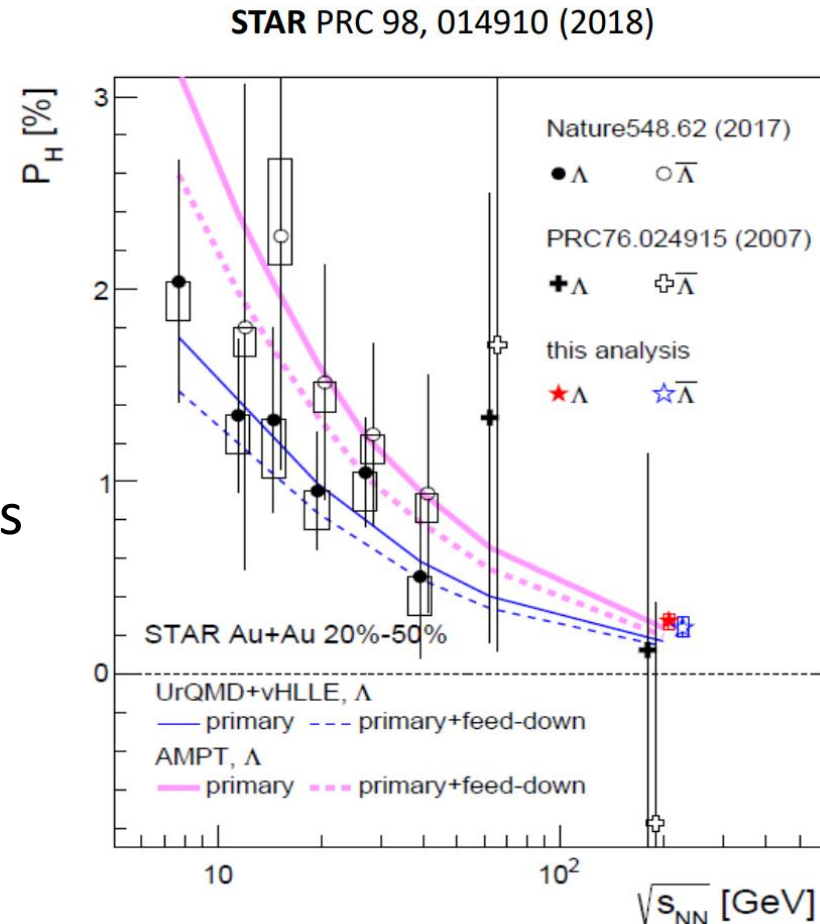

The STAR experiment

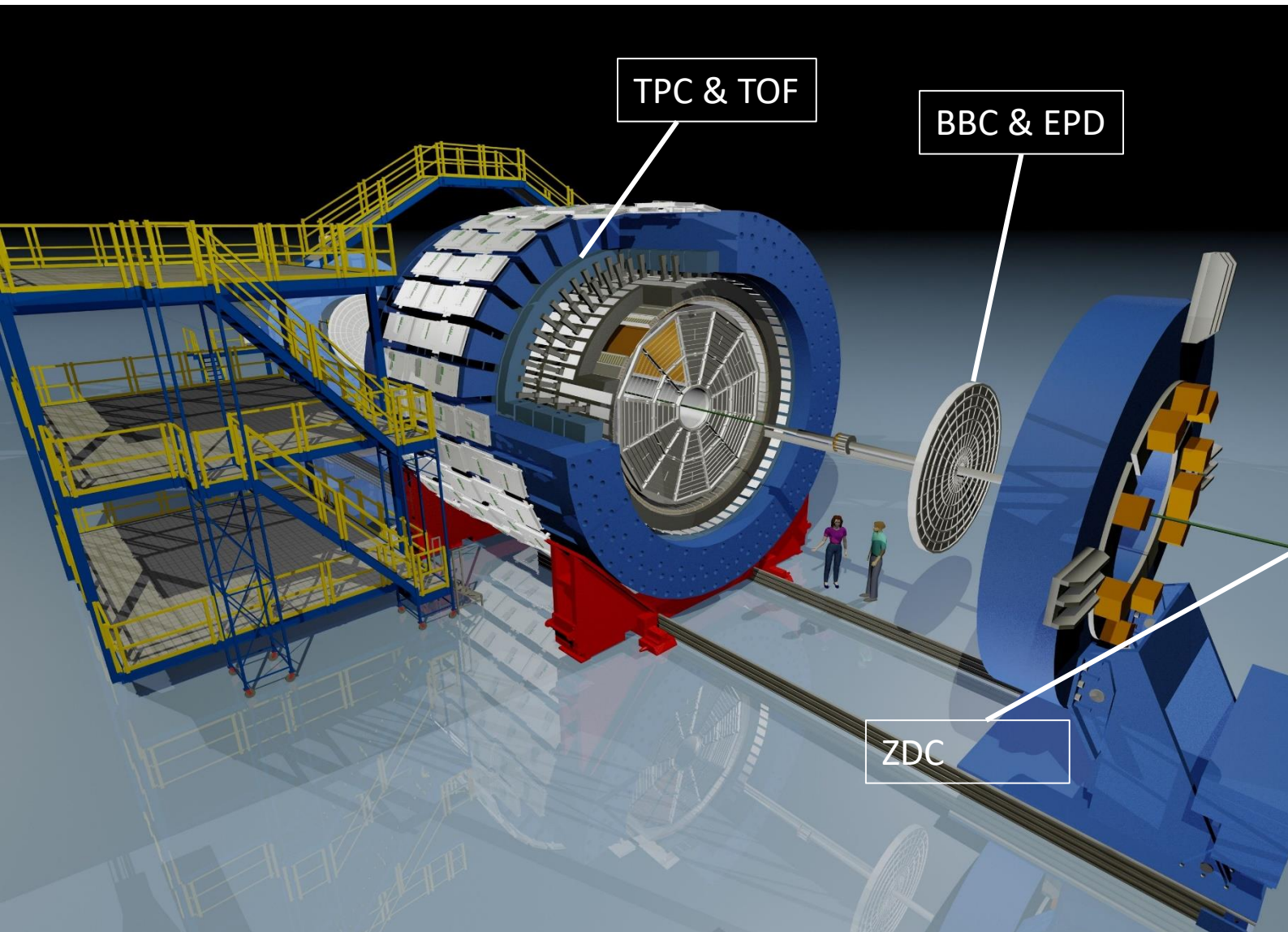

Hyperon reconstruction:

- Time Projection Chamber
 $|\eta| \in [-1, 1]$
- Time-Of-Flight
 $|\eta| \in [-0.9, 0.9]$

Event plane angle measurement:

- Beam-Beam Counter
 $|\eta| \in [3.3, 5.0]$
- Event-Plane Detector
 $|\eta| \in [2.1, 5.1]$
- Zero Degree Calorimeter
 $|\eta| > 6.3$

Experimental technique



- **Event plane** Ψ_1 is determined by detectors at forward rapidity where directed flow is large

$$\Psi_1 = \tan^{-1} \left(\frac{\sum w_i \sin(\phi_i)}{\sum w_i \cos(\phi_i)} \right), \text{ where } w_i \text{ is detector's tile ADC}$$

- $Res(\Psi_{1,Forward \eta}) = Res(\Psi_{1,Backward \eta}) = \sqrt{\langle \cos(\Psi_{1,Forward \eta} - \Psi_{1,Backward \eta}) \rangle}$
- BBC and ZDC for $\sqrt{s_{NN}} = 54.4$ GeV, EPD and BBC for $\sqrt{s_{NN}} = 27$ GeV

A. M. Poskanzer, S. A. Voloshin, PRC58.1671(1998)

- **Hyperon reconstruction** performed via decay topology
- Λ daughters identified via TPC and TOF
- Ξ were reconstructed via $\Xi \rightarrow \Lambda + \pi$

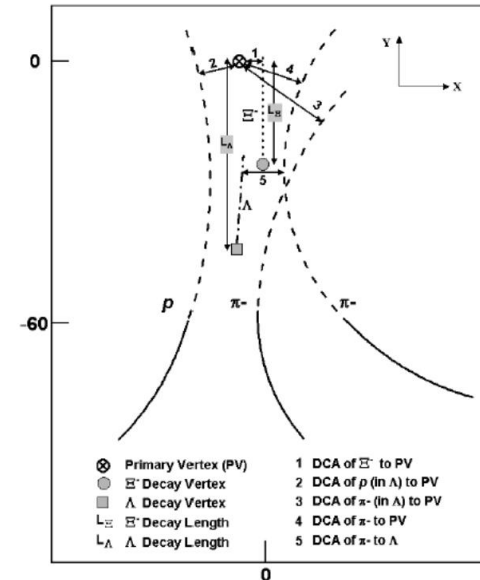
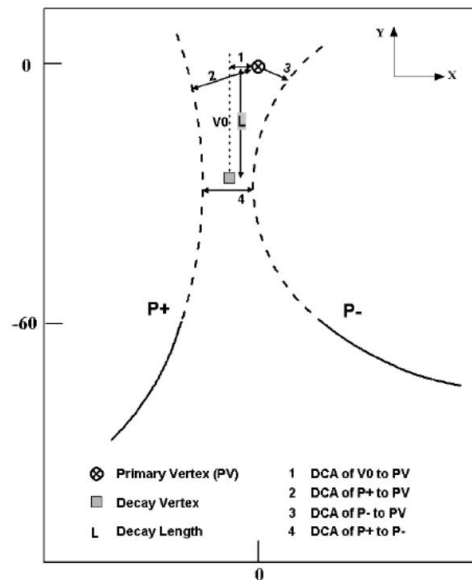
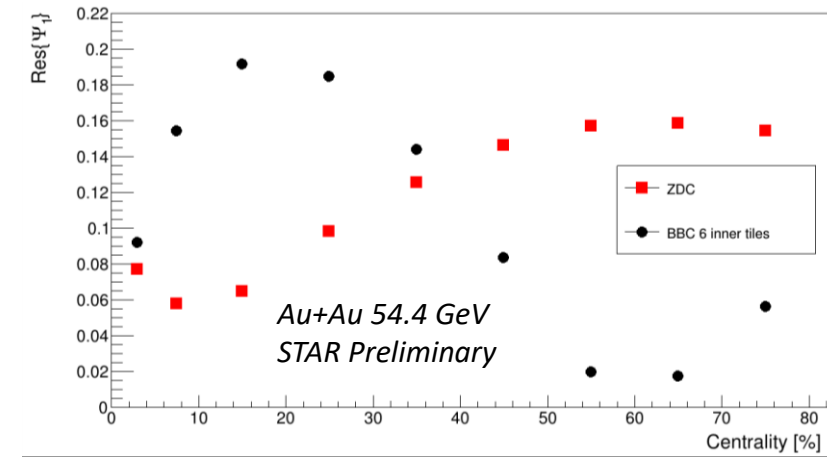

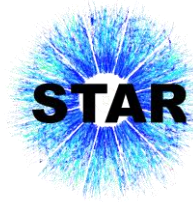

Global polarization: event-plane method

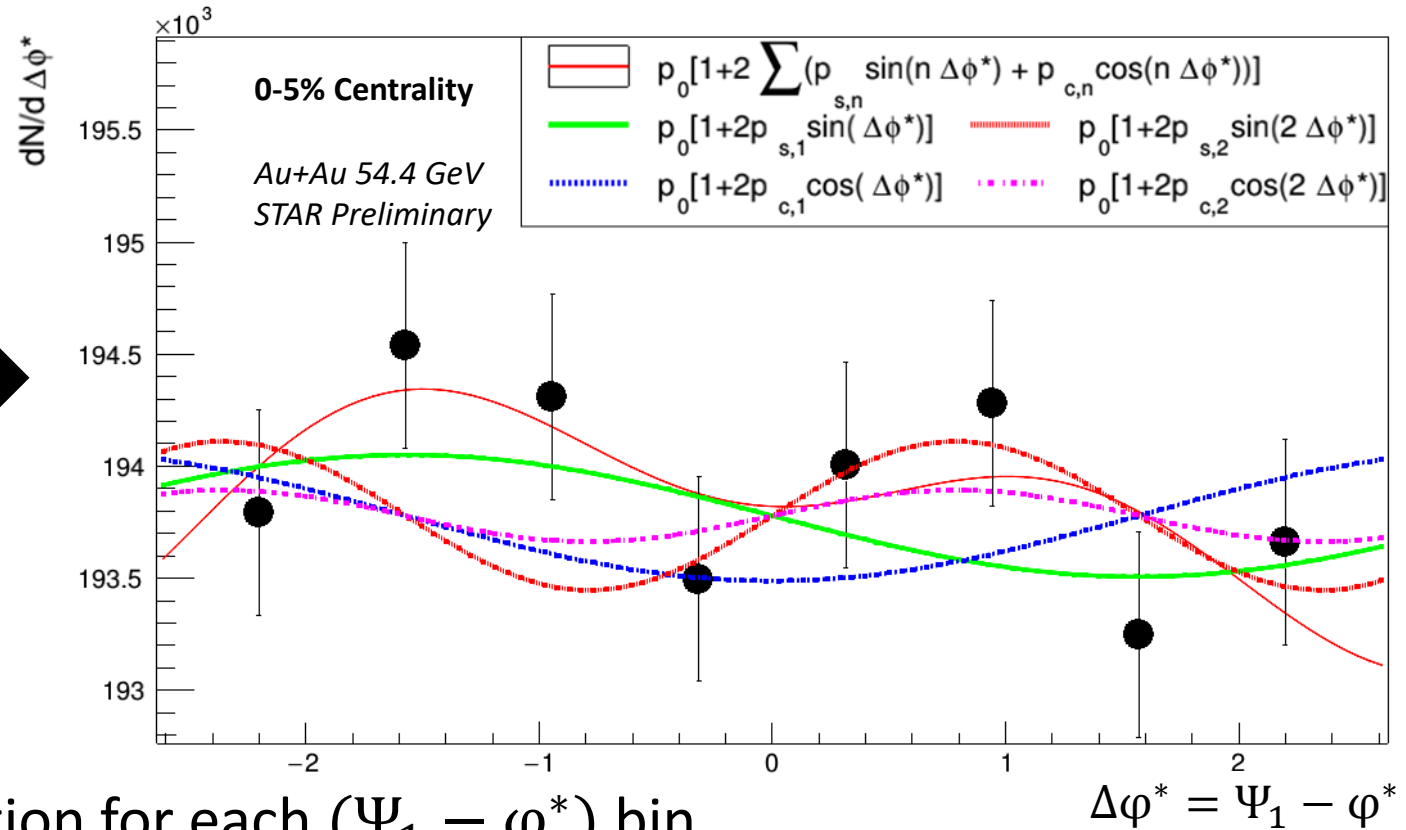
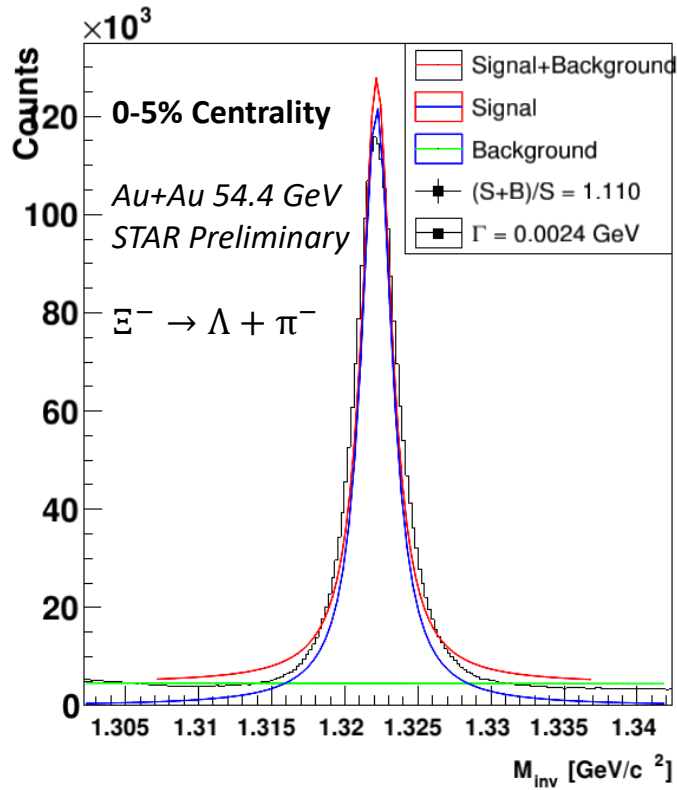

- Build invariant mass distribution for each $(\Psi_1 - \varphi^*)$ bin
- Subtract background and integrate subtracted distribution
- Fit $dN/d(\Psi_1 - \varphi^*)$ with Fourier function up to 2nd order
- Coefficient for $\sin(\Delta\varphi^*)$ term is what we're looking for

$$\Delta\varphi^* = \Psi_1 - \varphi^*$$

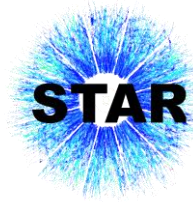

Results

- Global polarization of Ξ hyperons consistent with model predictions
- Experimental results for Ξ global polarization consistent with each other with given large uncertainties at different collision energies
- Ξ global polarization, measured via its daughter Λ decays is consistent with direct method
- Ξ and inclusive Λ global polarization are consistent within statistical uncertainties

Global hyperon polarization $\sqrt{s_{NN}}$ dependence

P_H (%)

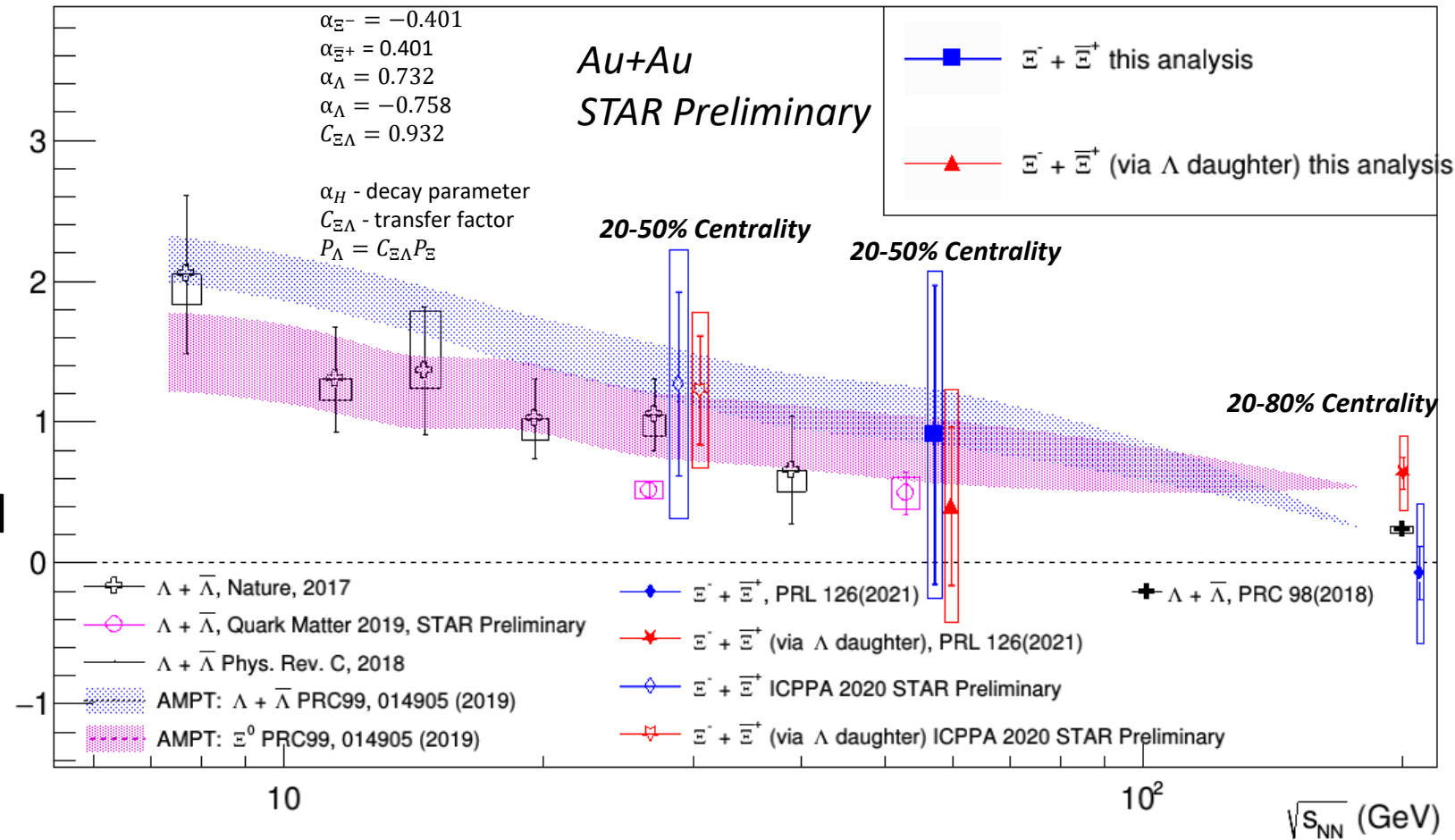

Conclusions



- We presented first results of $\Xi + \bar{\Xi}$ global polarization measurements in Au+Au collisions at 54.4 GeV
- $\Xi + \bar{\Xi}$ global polarization is comparable to $\Lambda + \bar{\Lambda}$ global polarization within uncertainties
- We are looking forward to continuing this measurements at other energies

Thank you for your attention!