

HXR monochromators

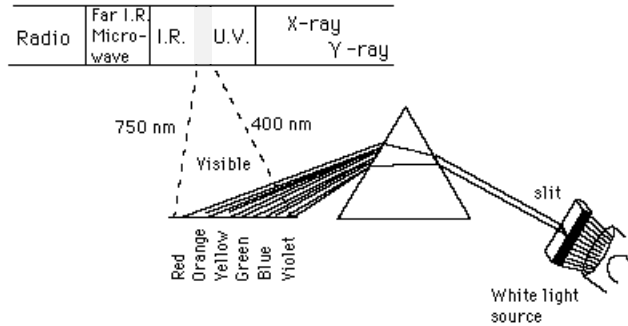

Micro wave	I.R.	Visible	U.V.	Soft X-ray	Hard X-ray
------------	------	---------	------	------------	------------

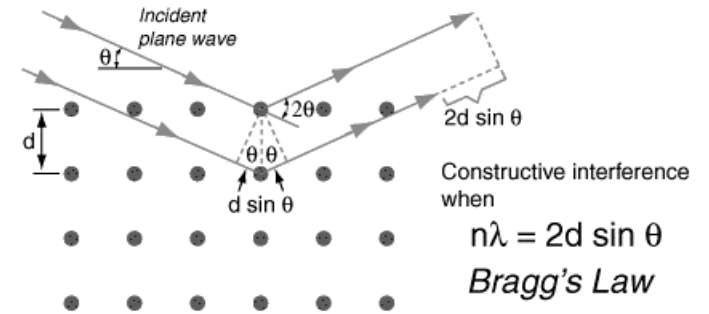

Micro wave	I.R.	Visible	U.V.	Soft X-ray	Hard X-ray
------------	------	---------	------	------------	------------

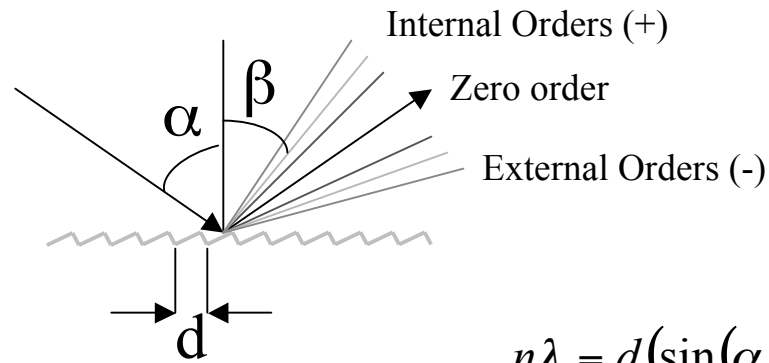
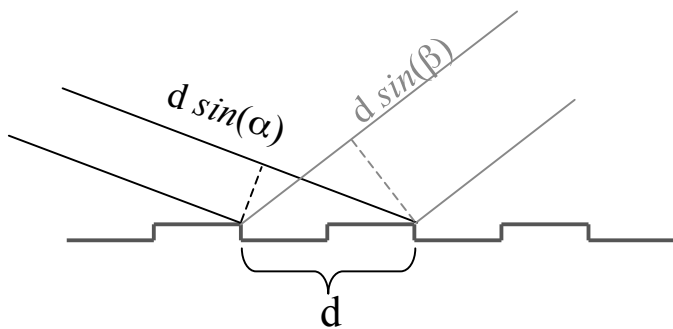

$$n\lambda = d(\sin(\alpha) - \sin(\beta))$$

Bragg law

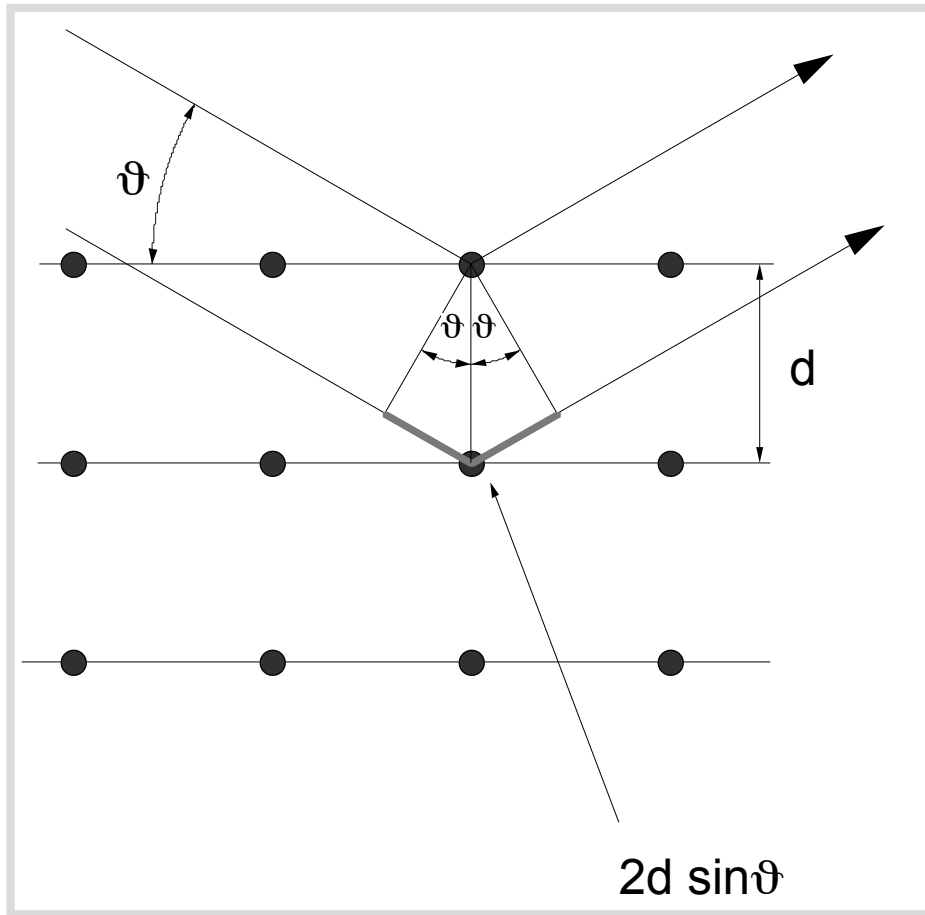

Radiation of wavelength λ is reflected by the lattice plane. The outgoing waves interfere. The interference is constructive only if the difference of optical path is a multiple of λ :

$$2d \sin \vartheta = n \lambda$$

Limits:

$$\sin \vartheta = 1 \Rightarrow \lambda_{\max}$$

$$\lambda_{\max} = 2d \quad @ \theta = 90^\circ$$

EXAMPLES: $Si (111) \quad d = 3.13 \text{ \AA} \rightarrow E_{\min} \approx 2 \text{ keV}$

$InSb (111) \quad d = 3.74 \text{ \AA} \rightarrow E_{\min} \approx 1.7 \text{ keV}$

$Si (311) \quad d = 1.64 \text{ \AA} \rightarrow E_{\min} \approx 3.8 \text{ keV}$

$Beryl (10\bar{1}0) \quad d = 7.98 \text{ \AA} \rightarrow E_{\min} \approx 0.8 \text{ keV}$

Energy Resolution

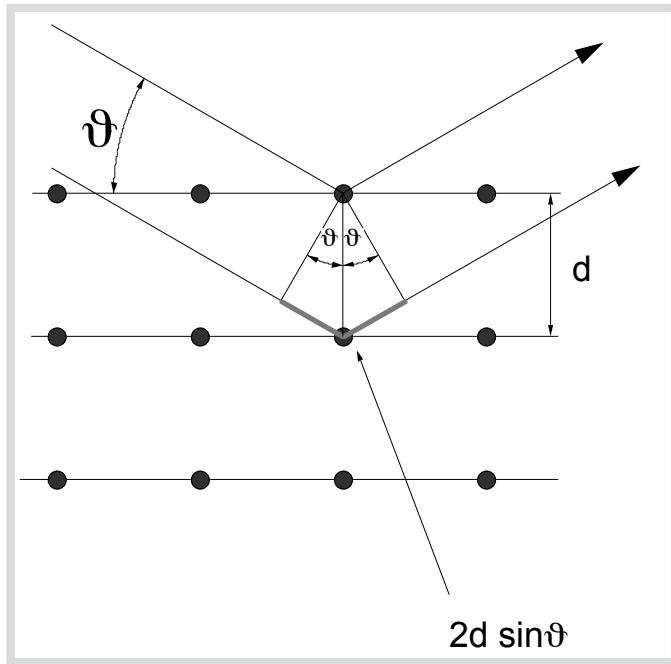

$$\frac{\Delta\lambda}{\lambda} = \frac{\Delta E}{E} = \Delta\vartheta \cot g(\vartheta)$$

$$\frac{\delta\lambda}{\delta\vartheta} = \frac{2d \cos\vartheta}{n} \rightarrow \frac{\delta\lambda}{\lambda} = \frac{2d \cos\vartheta}{n} * \frac{n}{2d \sin\vartheta} * \delta\vartheta$$

$\Delta\vartheta$ has two contribution :

$\Delta\vartheta_{\text{beam}}$ beam angular divergence

ω_{crystal} intrinsic reflection width of the monochromator

$$2d \sin\vartheta = n\lambda$$

Beam divergence

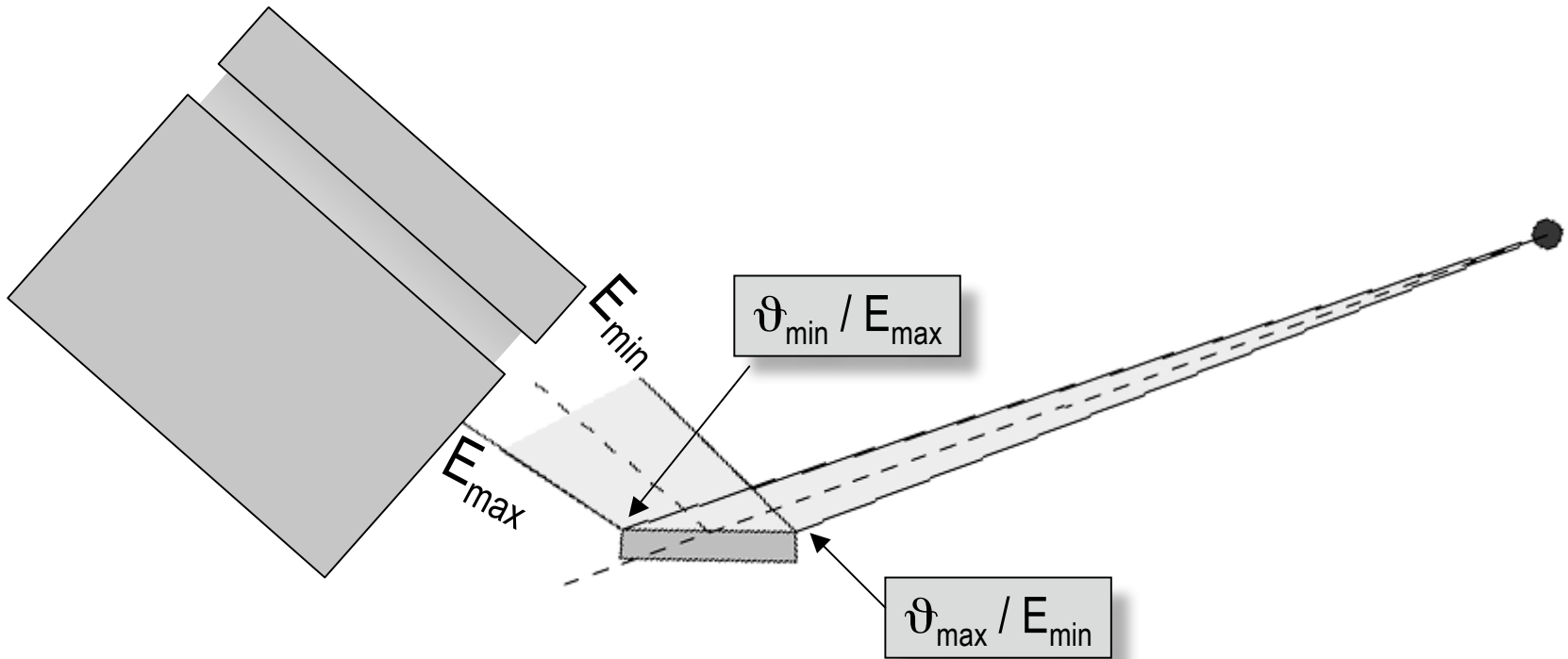

$$2d \cdot \sin \vartheta = n\lambda$$

$$\Delta \vartheta = \vartheta_{\max} - \vartheta_{\min}$$

$$2d \cdot \sin \vartheta_{\min} = n\lambda_0$$

$$2d \cdot \sin \vartheta_{\max} = n\lambda_1$$

$$\Delta \lambda \propto \Delta \vartheta$$

Beam divergence

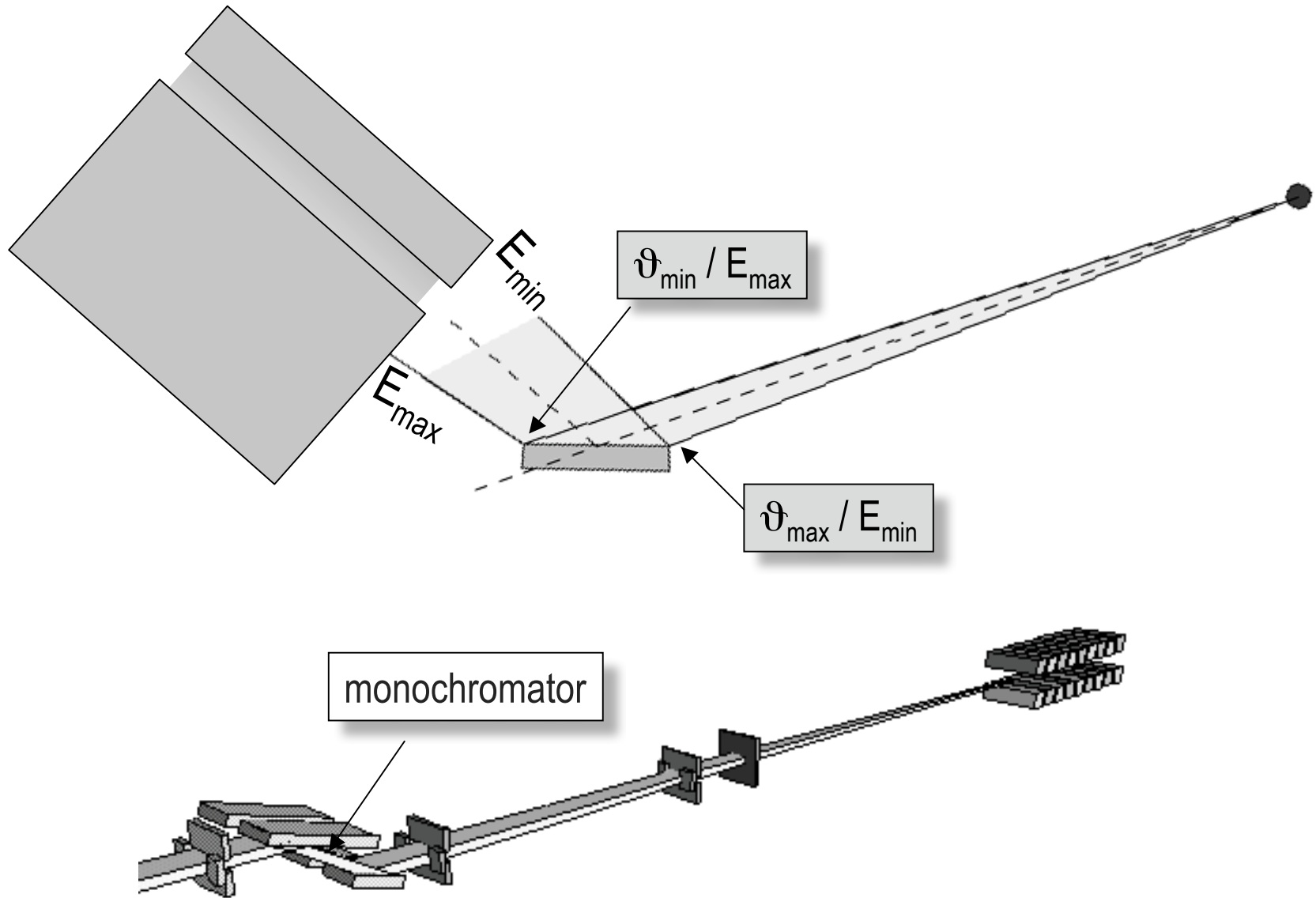

Collimating mirror

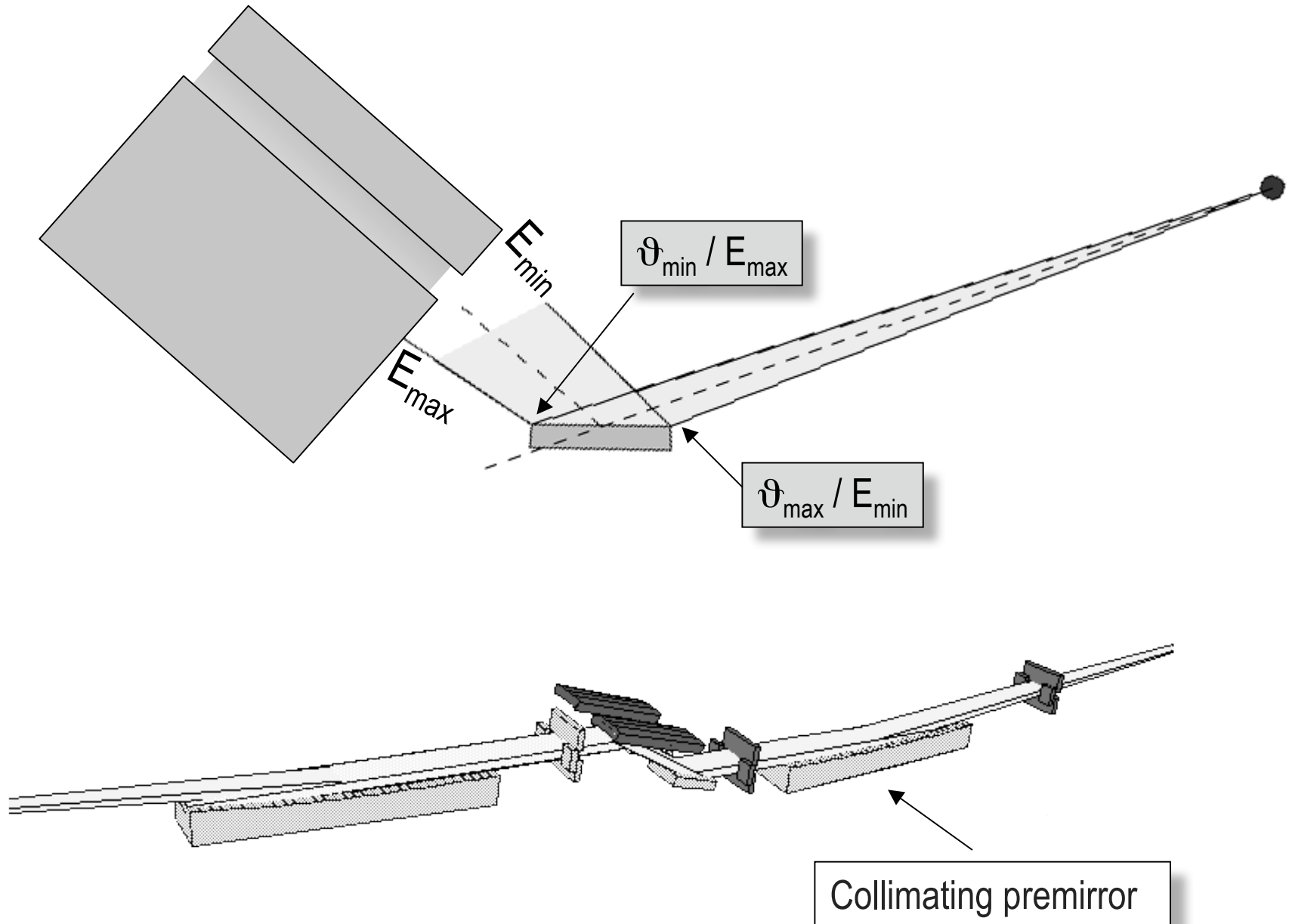

Collimating mirror

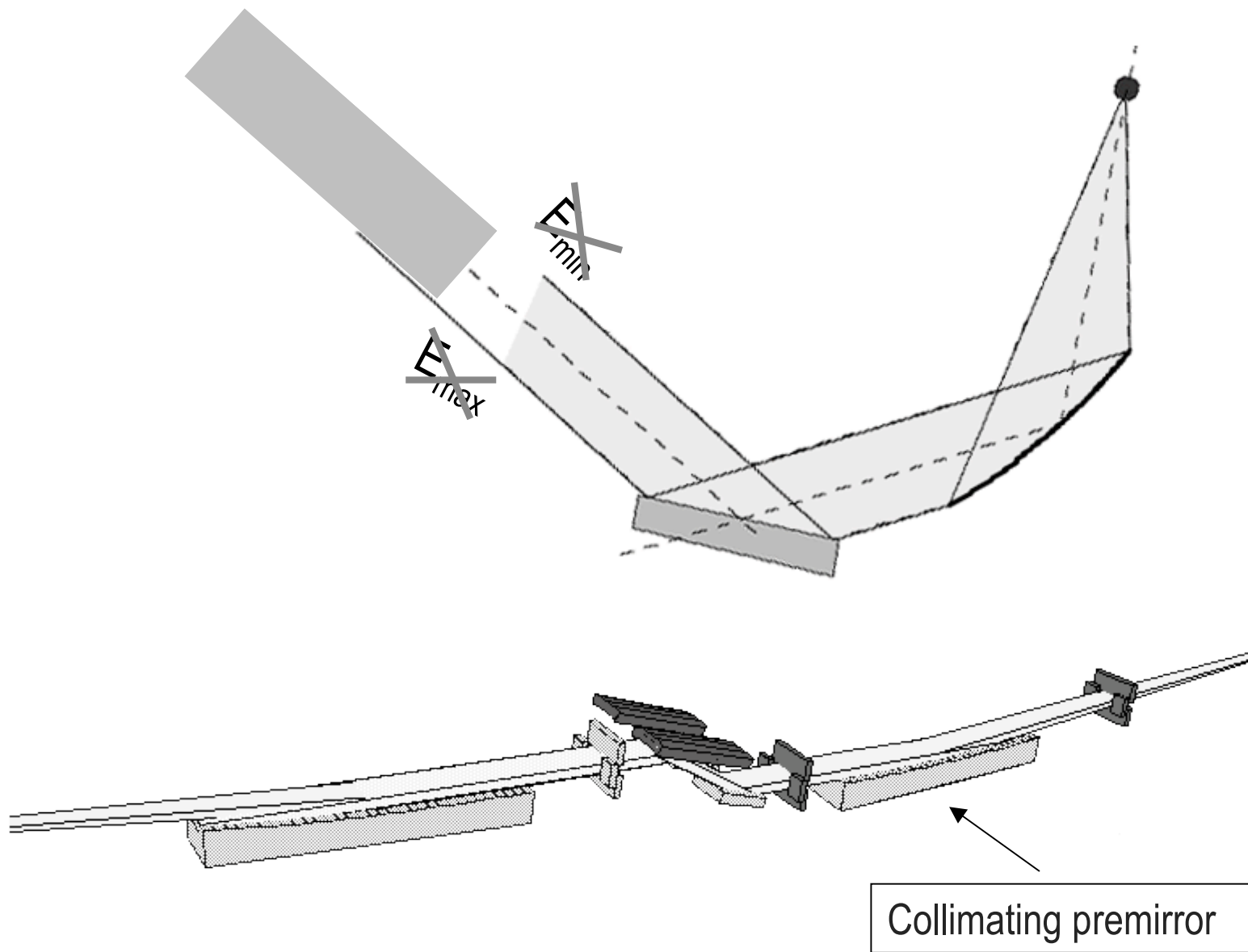

The Darwin curve

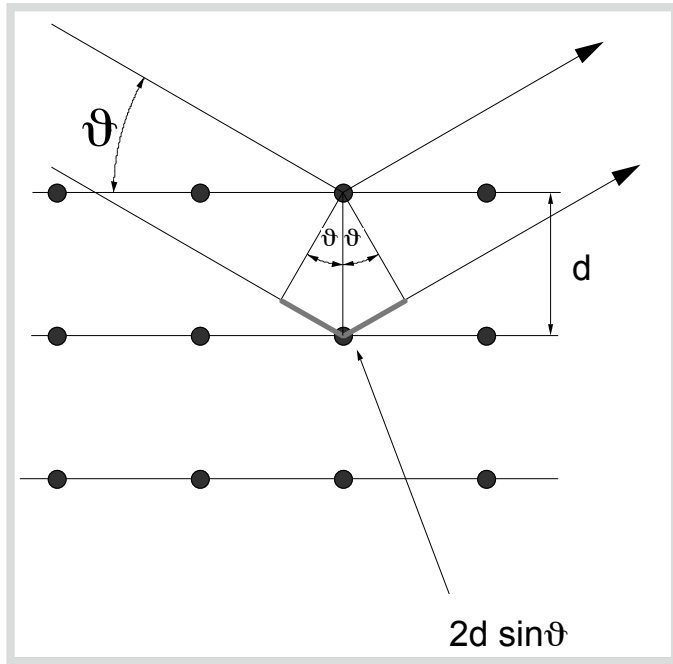

$$\frac{\Delta \lambda}{\lambda} = \frac{\Delta E}{E} = \Delta \vartheta \cot g(\vartheta)$$

$\Delta \vartheta$ has two contribution :

$\Delta \vartheta_{\text{beam}}$ beam angular divergence

ω_{crystal} intrinsic reflection width of the monochromator

The Darwin curve

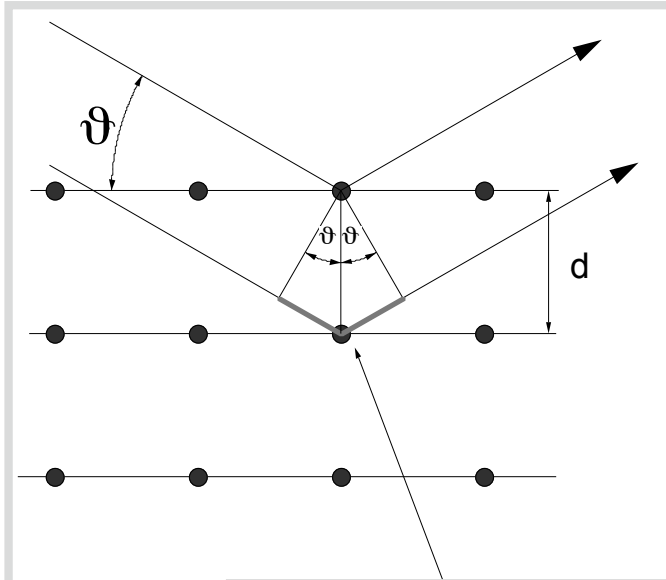

$$\omega_S = \frac{2}{\sin 2\vartheta_B} \frac{r_e \lambda^2}{\pi V} C |F_{hr}| e^{-M}$$

- n order of the reflection
- λ_1 wavelength of the fundamental
- $e^{-M(n)}$ temperature factor
- V volume of the unit cell
- ϑ_B Bragg angle
- R_e radius of the electron e^2/mc^2

F_{hr} real part of the structure factor related to the diffracted direction $\mathbf{h}(h,k,l)$

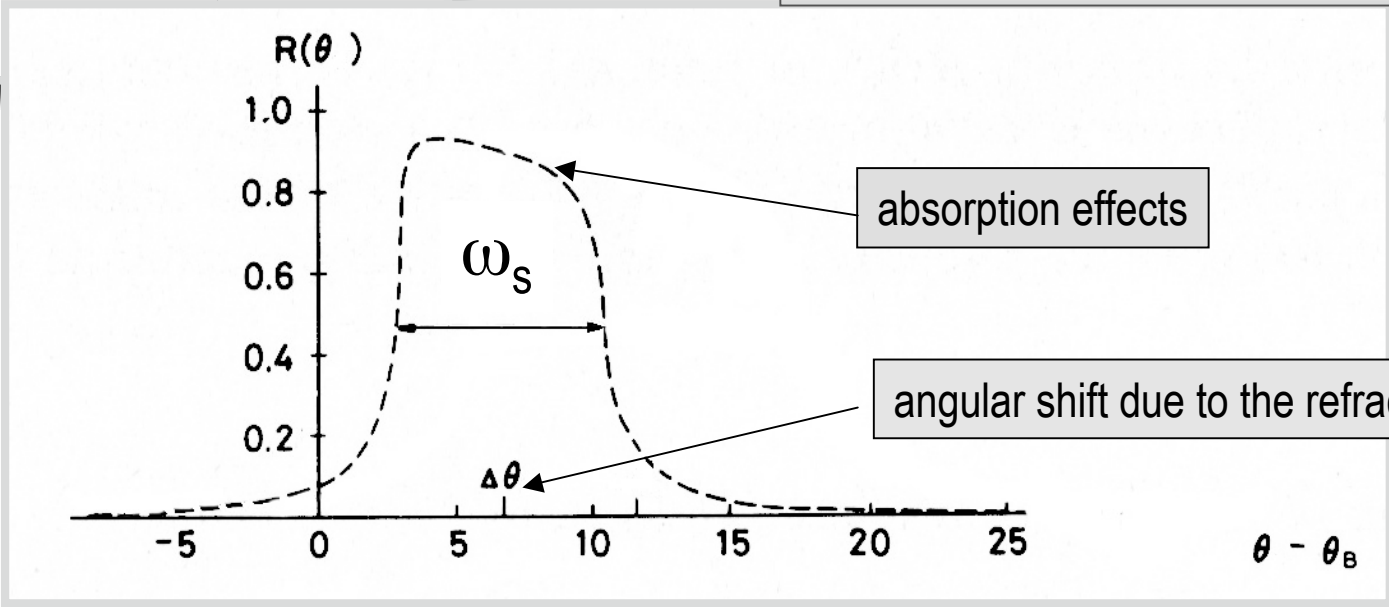

DuMond Diagram

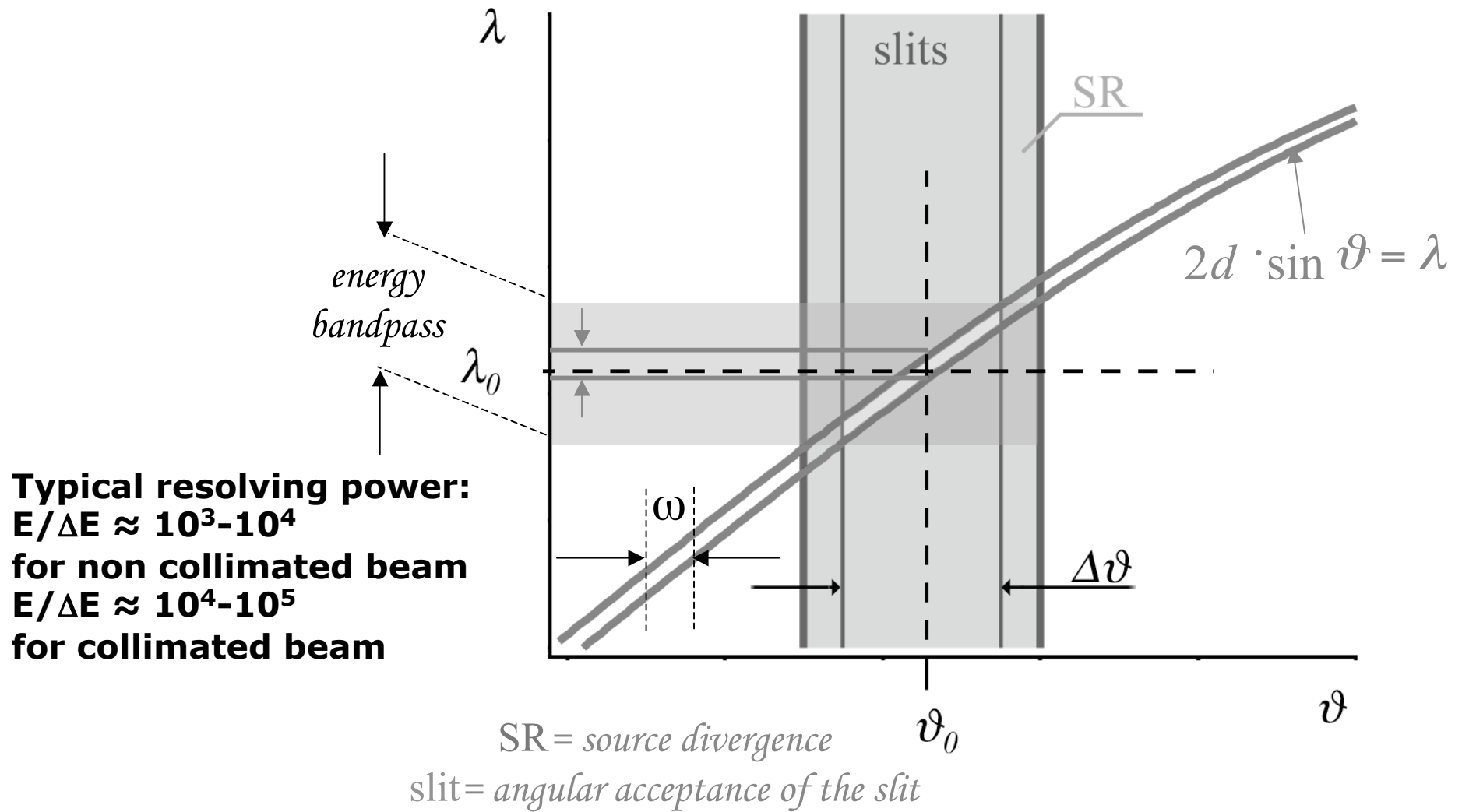

Crystal Monochromator

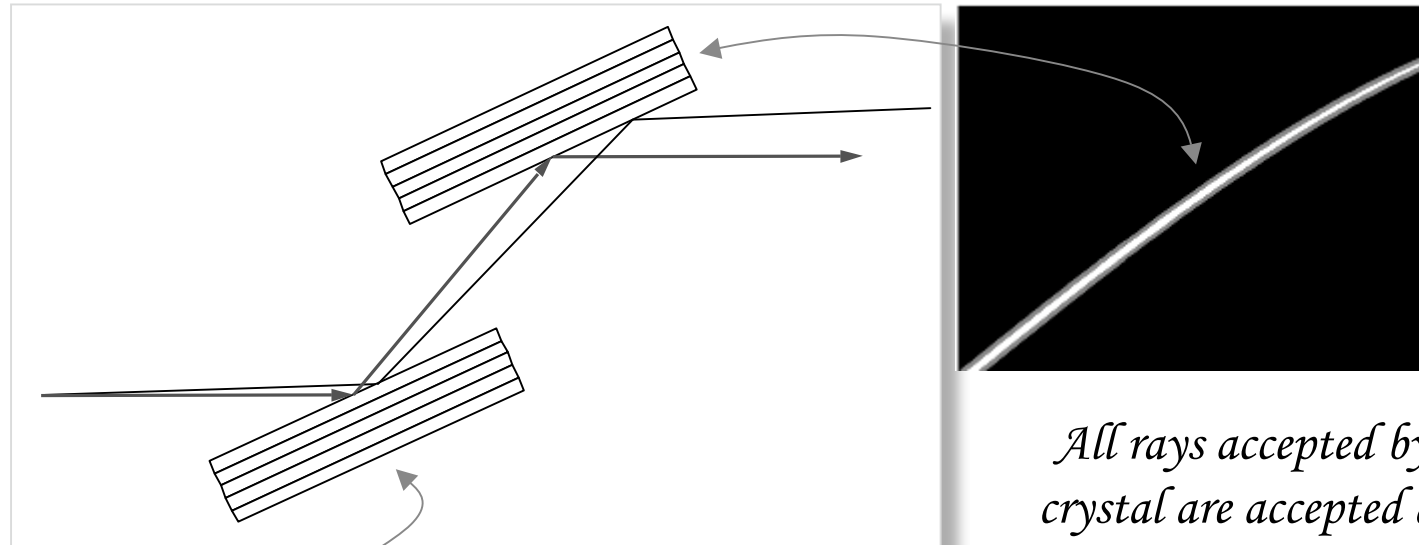

All rays accepted by the first crystal are accepted also at the second.

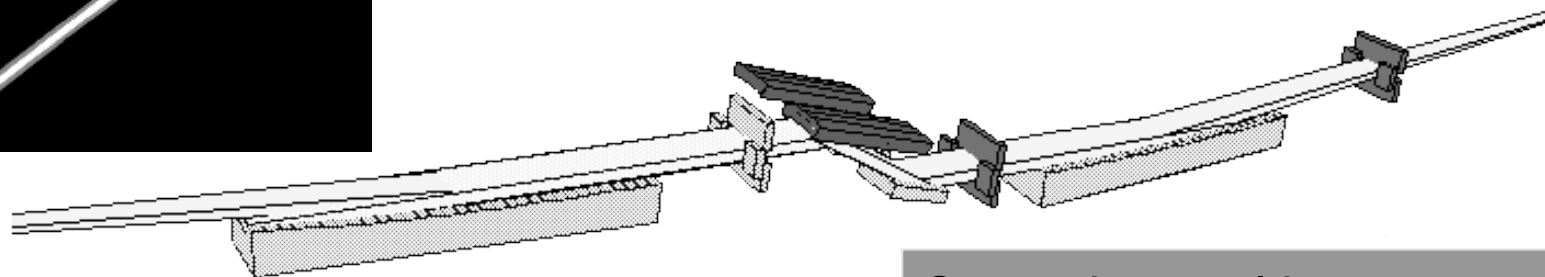
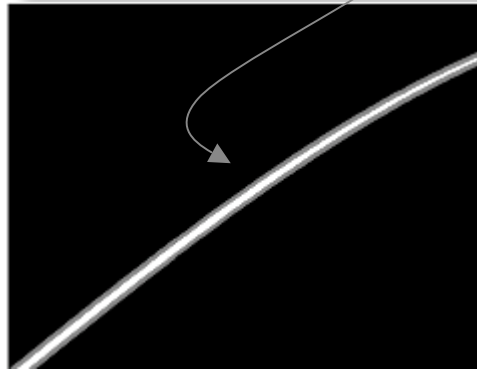

Second crystal in
non dispersive configuration

Channel cut

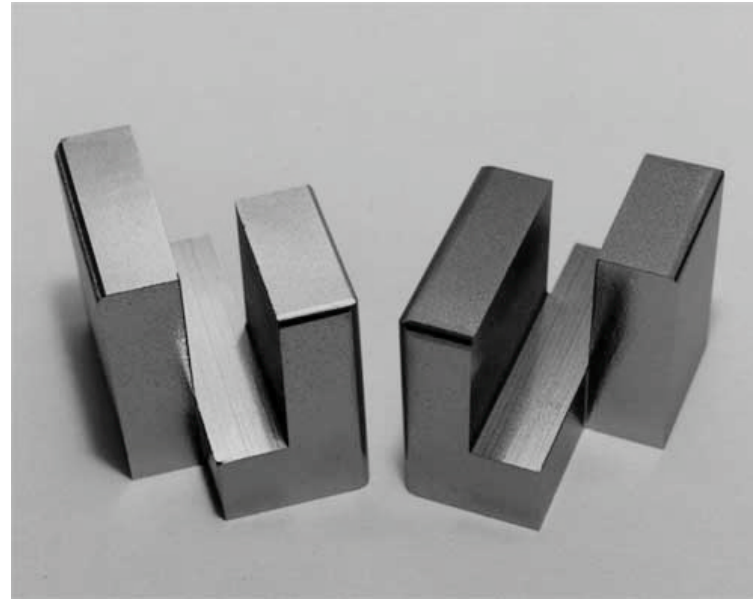
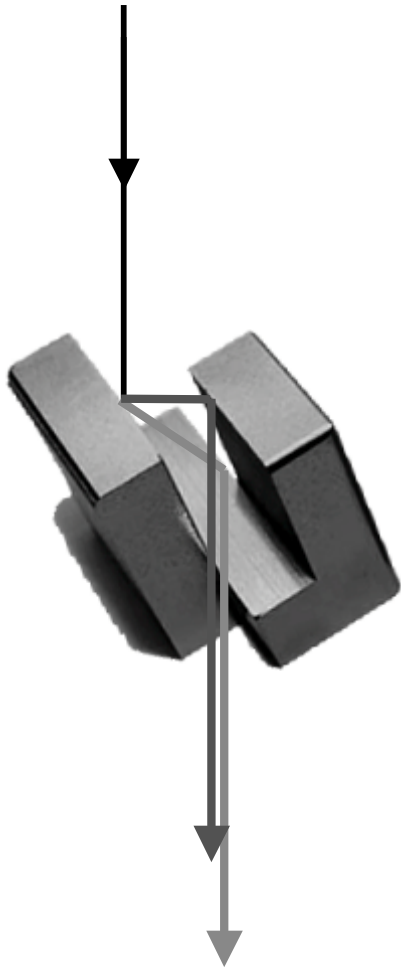

Channel cut

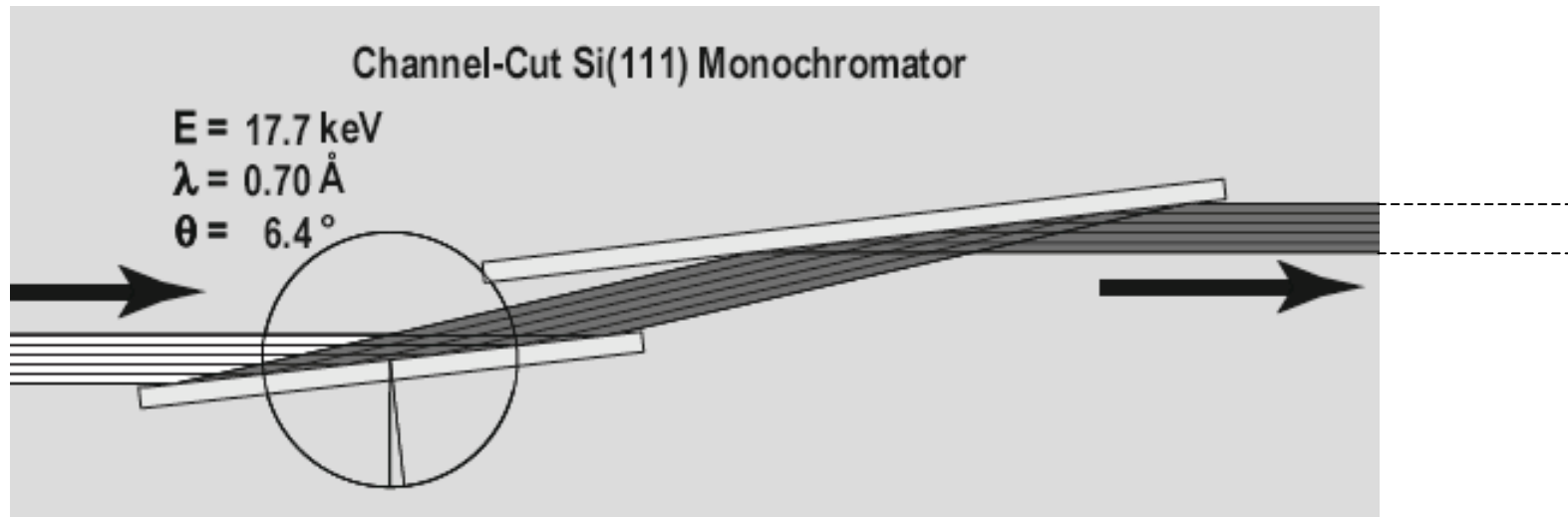

Much easier to allign!
Exit beam displacement!
Impossible to detune (No more true)

Double Crystal monochromator

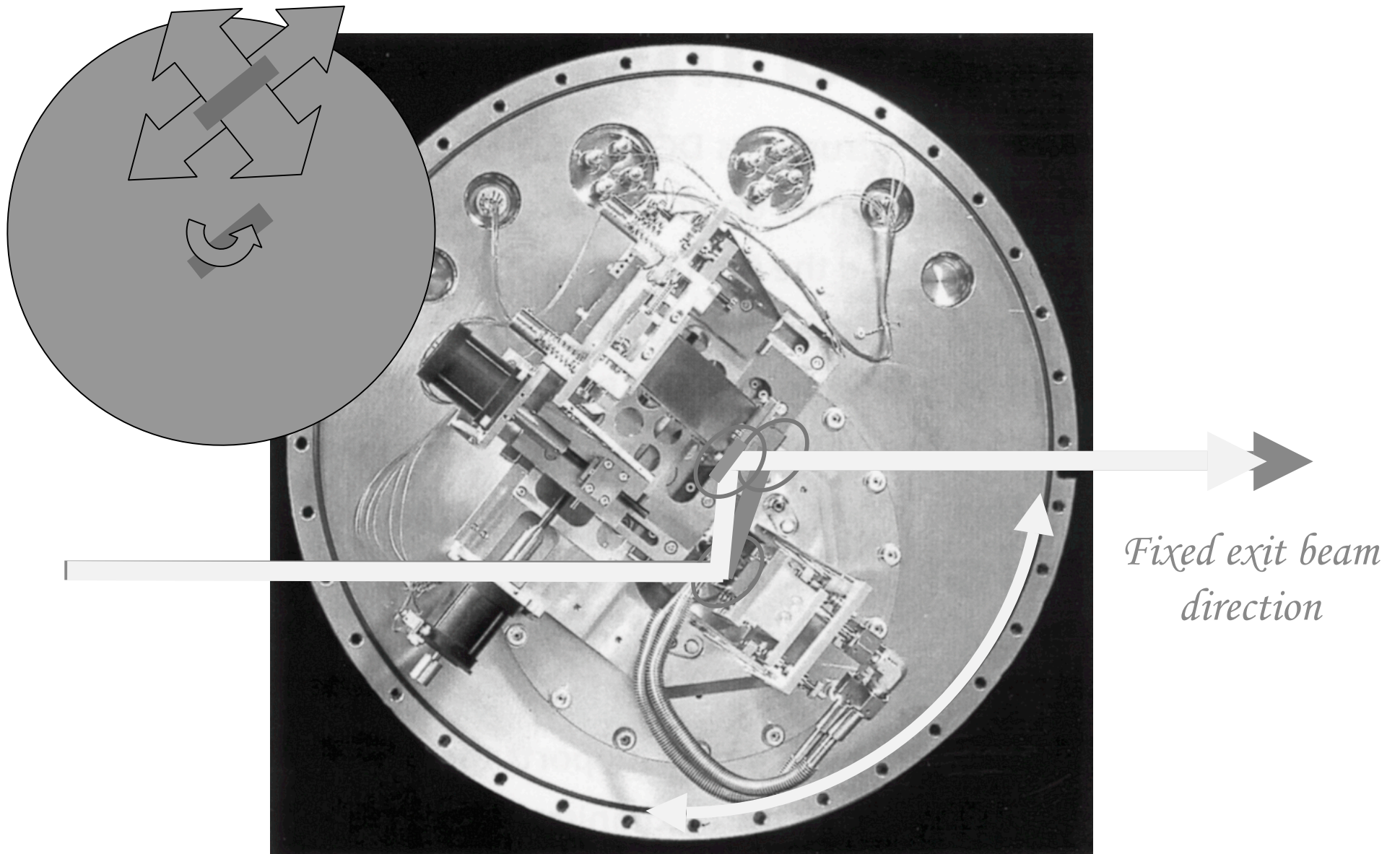

Twin Mic beamline

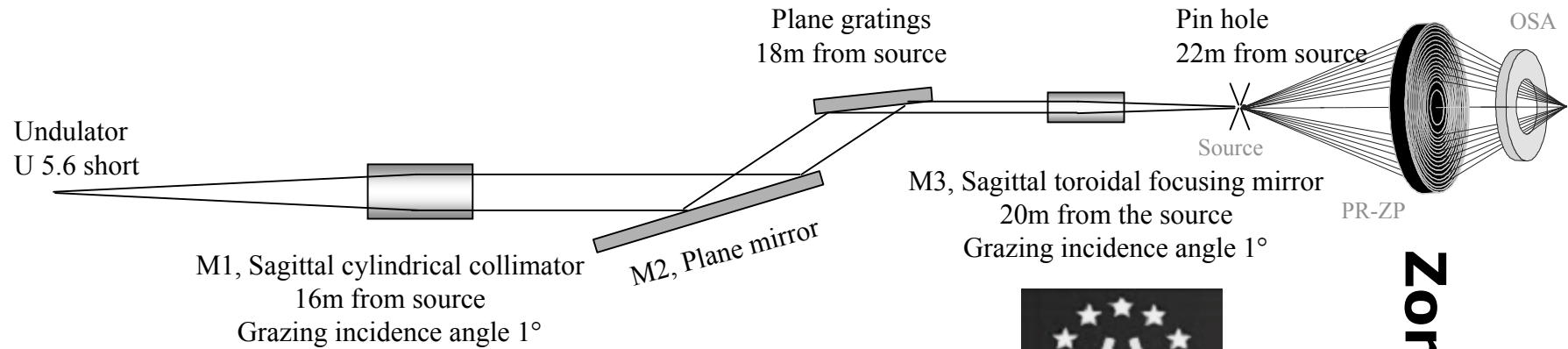

Zone plate



0.2-2keV (0.2-4keV desired) photon energy range

Moderate resolving power, high flux.

Fulfil the requirement of full field imaging and scanning mode

Zone Plate

Fresnel lens

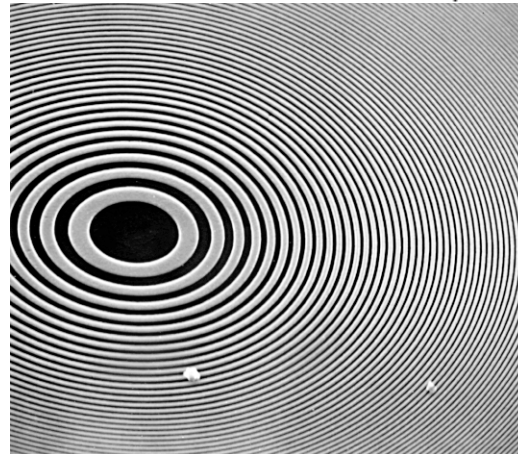
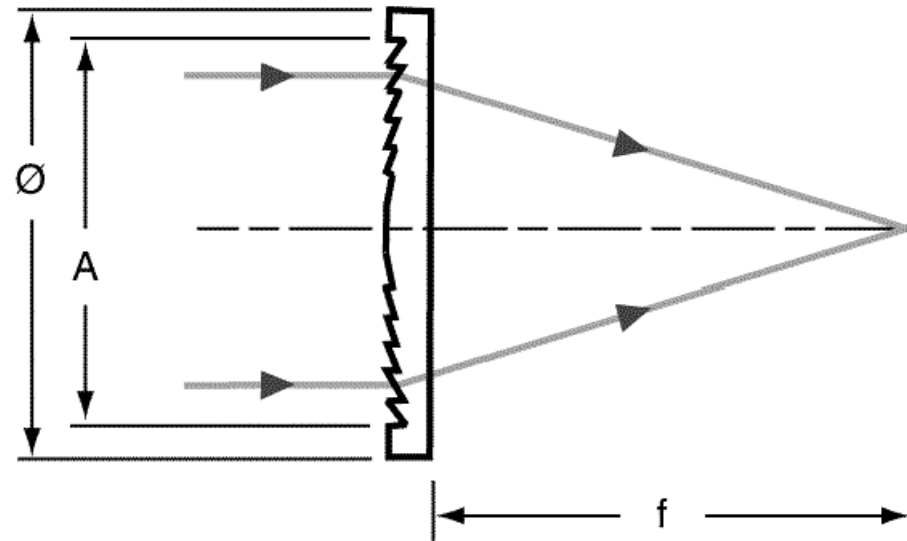
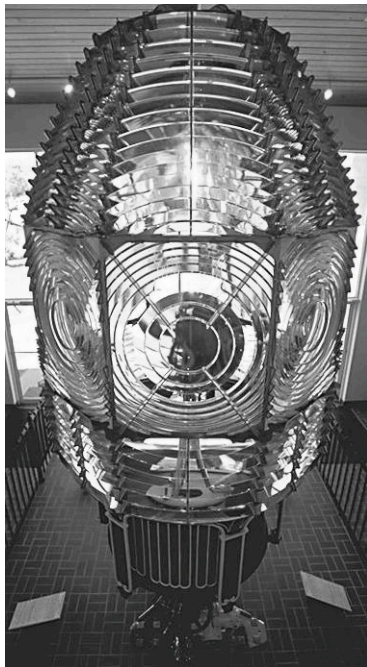

Zone Plate

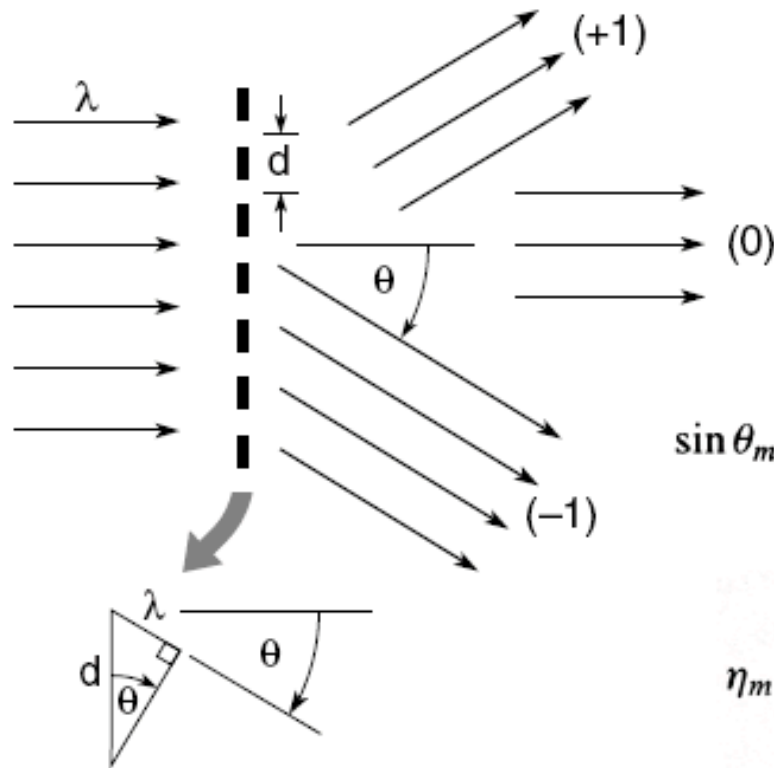

$$\sin \theta_m = \frac{m\lambda}{d} ; \quad m = 0, \pm 1, \pm 2, \pm 3,$$

$$\eta_m = \begin{cases} \frac{1}{4} & m = 0 \\ 1/m^2\pi^2 & m \text{ odd} \\ 0 & m \text{ even} \end{cases}$$

(50% absorbed)

Zone Plate

$$r_n^2 = fn\lambda$$

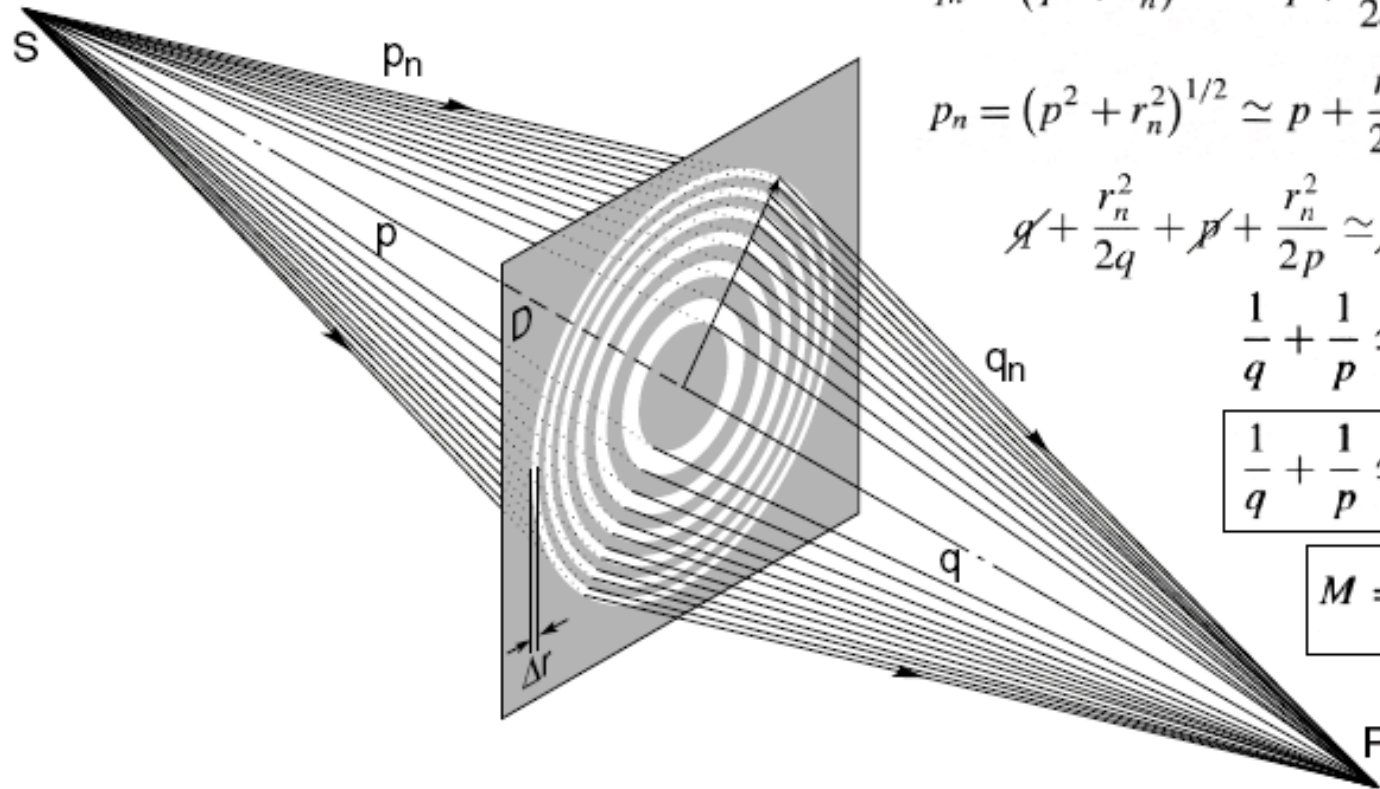

$$q_n + p_n = q + p + \frac{n\lambda}{2}$$

$$q_n = (q^2 + r_n^2)^{1/2} \simeq q + \frac{r_n^2}{2q}$$

$$p_n = (p^2 + r_n^2)^{1/2} \simeq p + \frac{r_n^2}{2p}$$

$$q + \frac{r_n^2}{2q} + p + \frac{r_n^2}{2p} \simeq q + p + \frac{n\lambda}{2}$$

$$\frac{1}{q} + \frac{1}{p} \simeq \frac{n\lambda}{r_n^2}$$

$$\frac{1}{q} + \frac{1}{p} \simeq \frac{1}{f}$$

$$M = \frac{p}{q}$$

Zone Plate

$$r_n^2 = fn\lambda$$

$$f = \frac{r_n^2}{n\lambda} = \frac{f_0}{n} \quad n \text{ odd}$$

$$\lambda = \frac{r_n^2}{nf} = \frac{\lambda_0}{n}$$

Higher order focused at different longitudinal positions

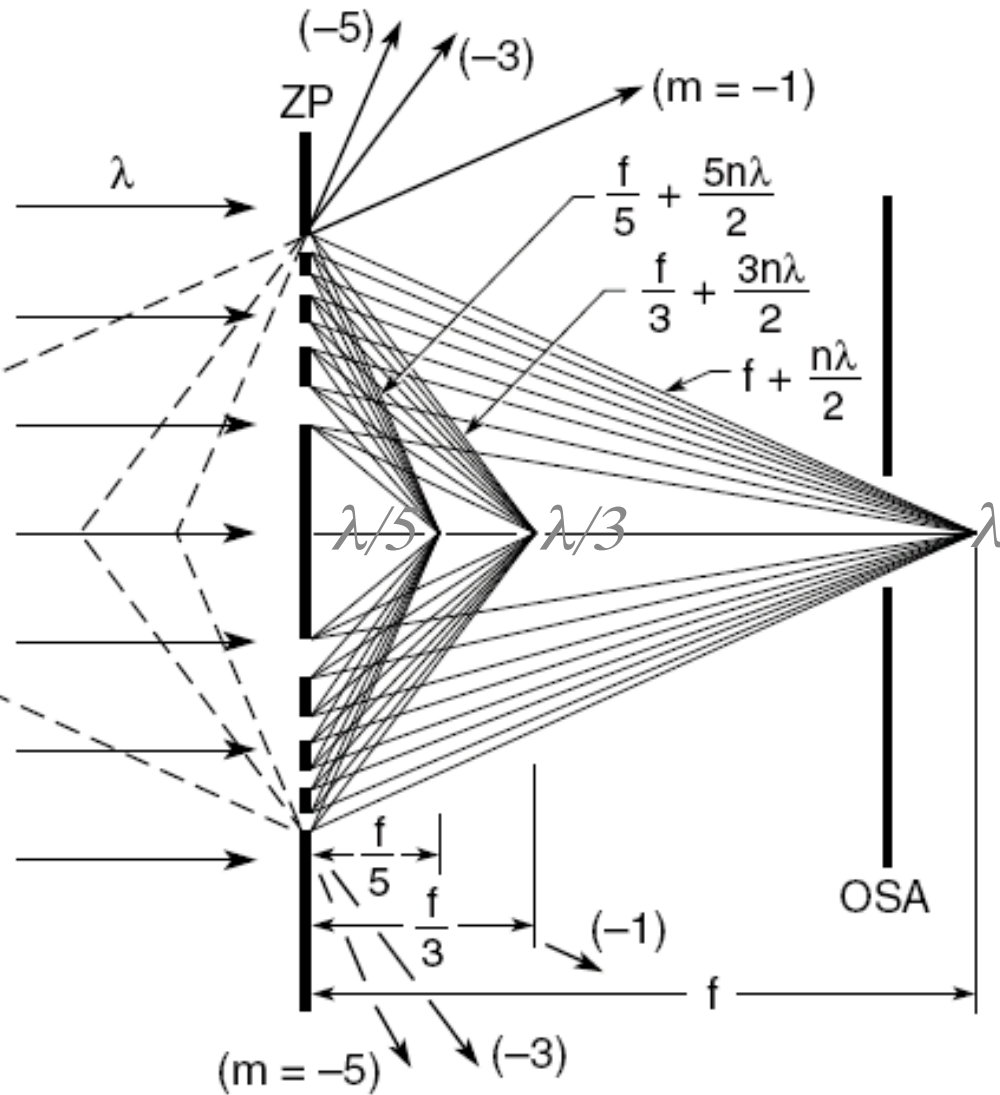

Zone Plate

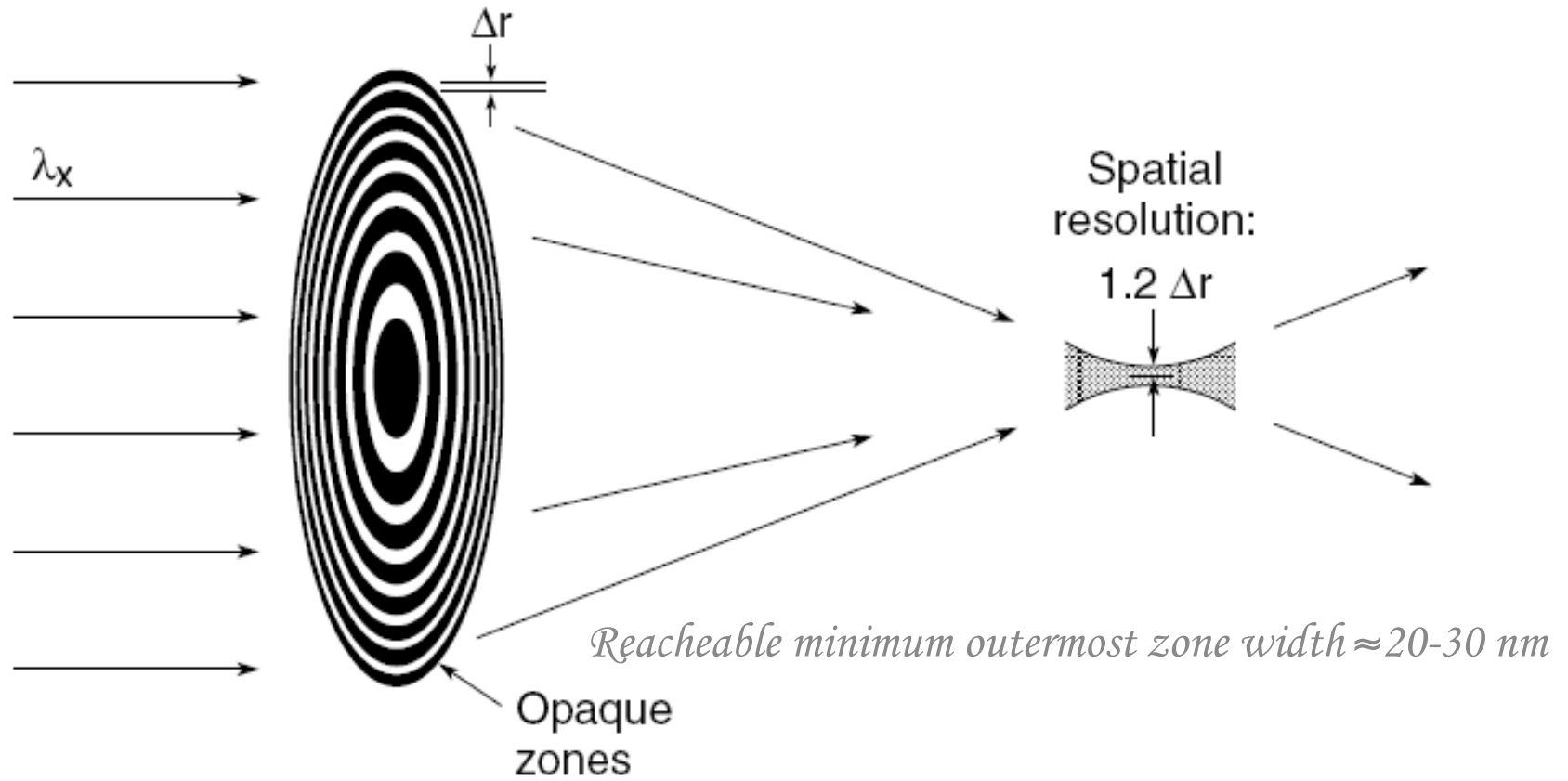

Microscopes

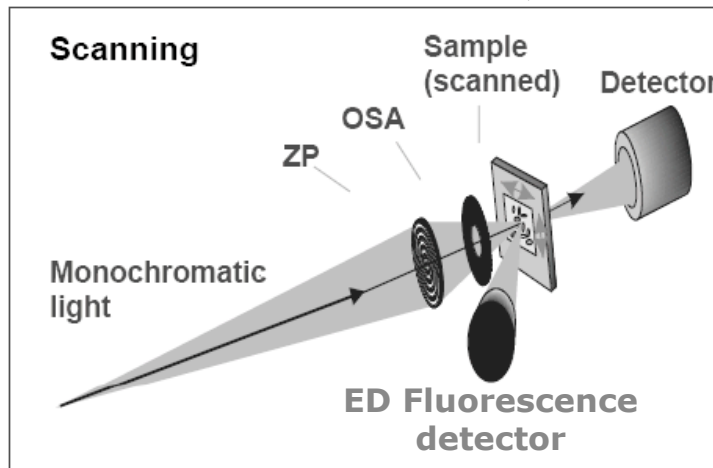
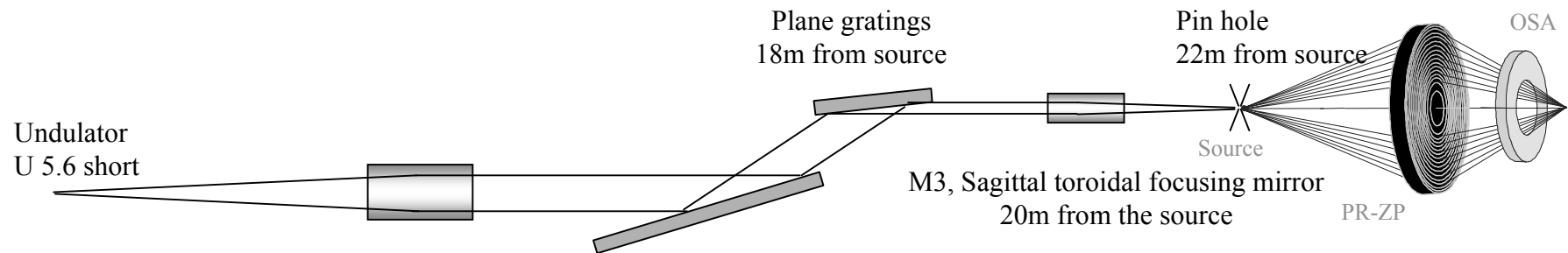

- + versatile detectors can run simultaneously;
- + easier optics set-up;
- long exposure time;
- complex electronics.

Ideal for spectromicroscopy

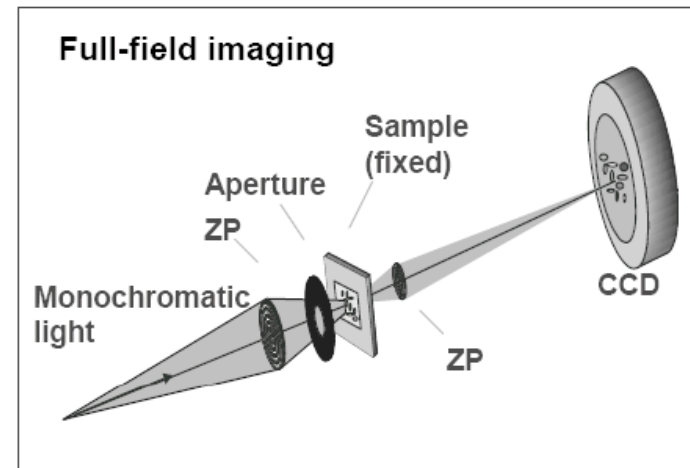

- + short exposure time;
- + higher resolution - static system;
- complex optical alignment.

Ideal for dynamic studies and tomography

Small spots - Large acceptance

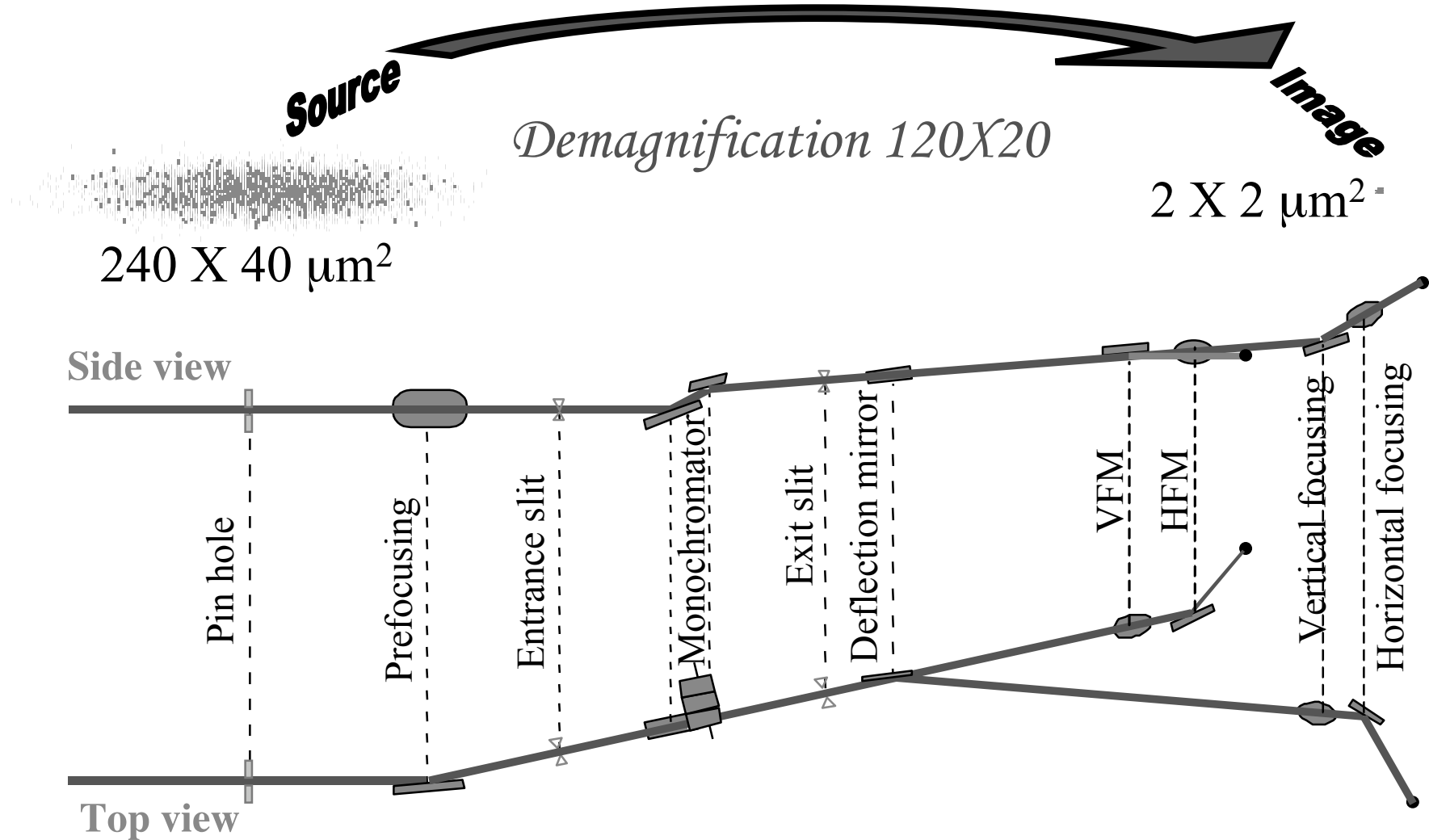

KB mirrors

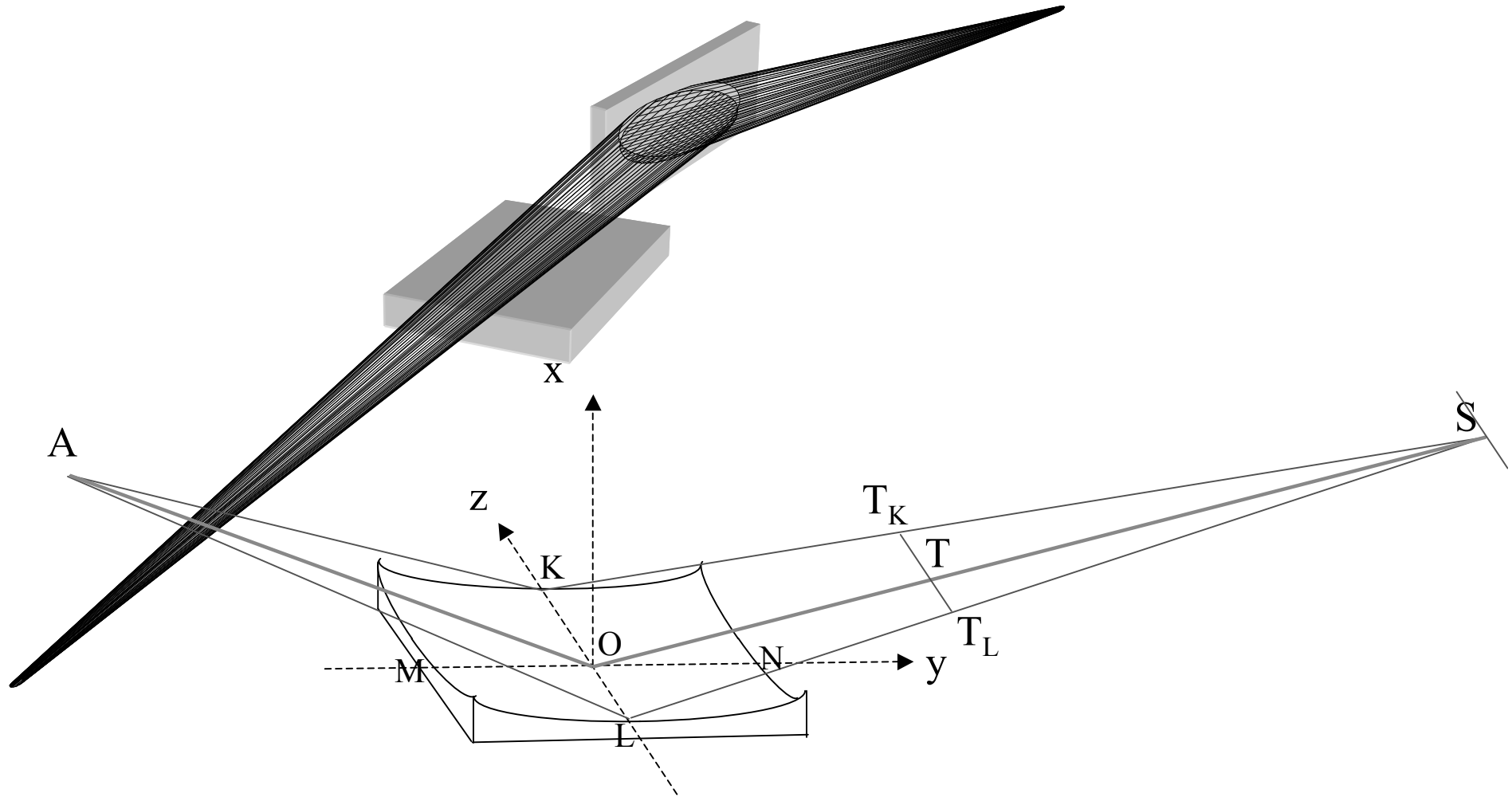

Small spot with KB

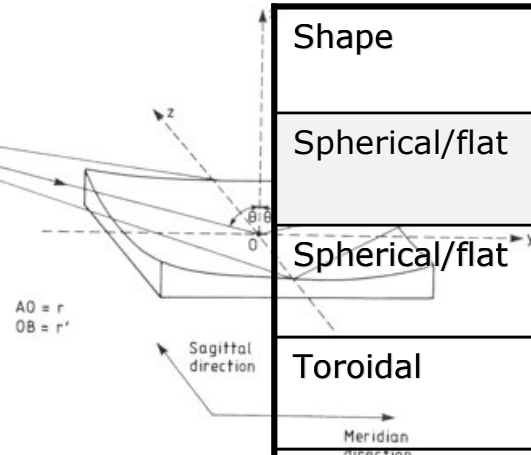
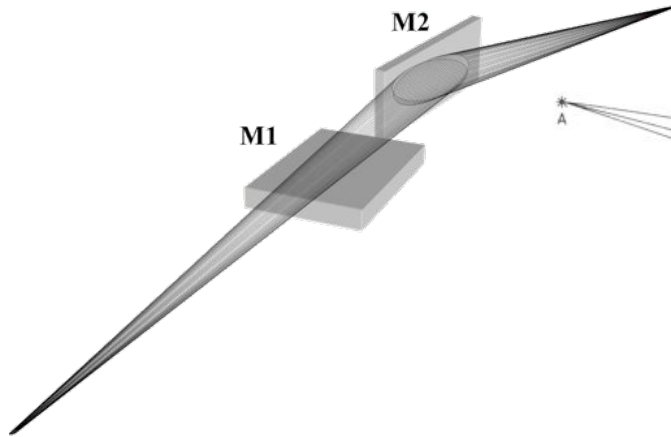

Shape	Length	rms errors
Spherical/flat	Up to 500 mm	< 0.5 μrad
Spherical/flat	> 500 mm	1-2 μrad
Toroidal	Up to 500 mm	< 1 μrad
Toroidal	> 500 mm	> 1 μrad
Aspherical	Up to 500 mm	2 μrad
Aspherical	> 500 mm	3-5 μrad

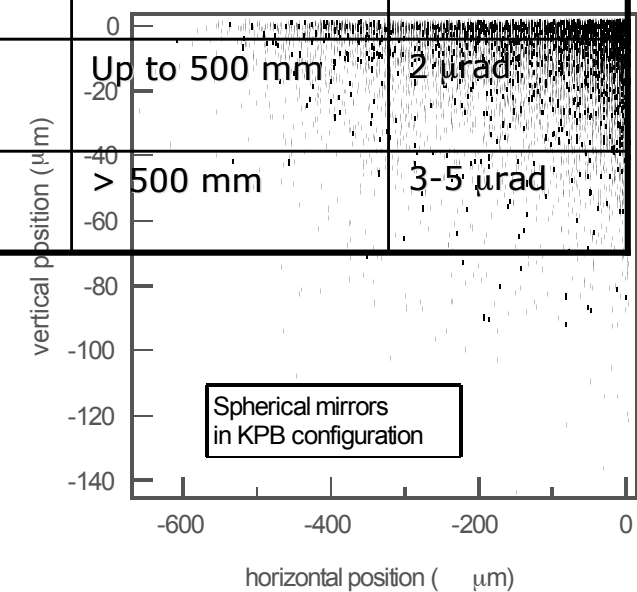
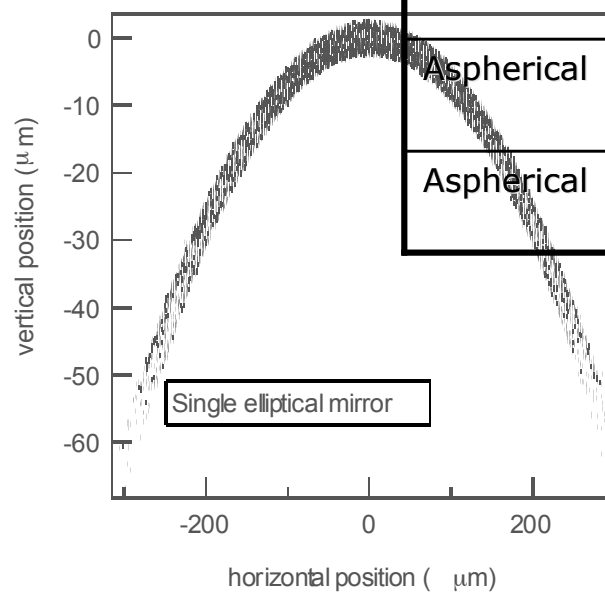
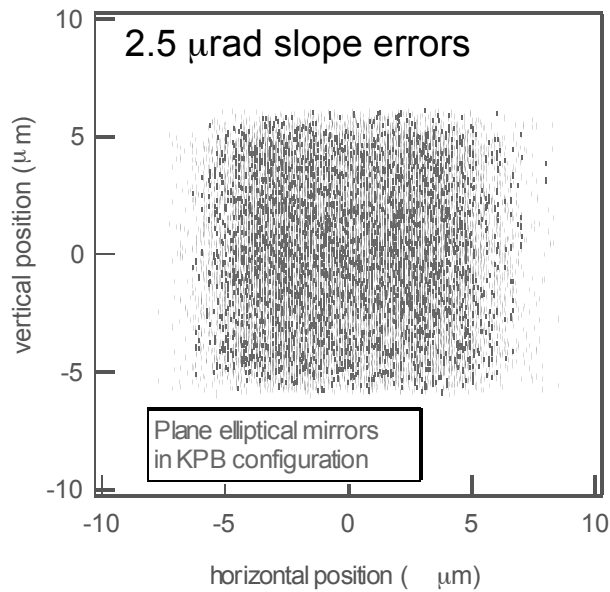

Approach best ellipse

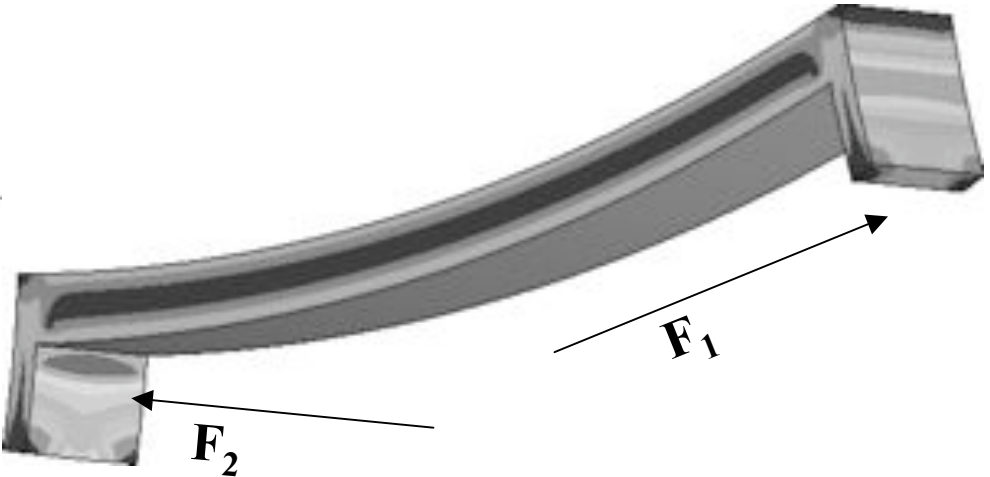
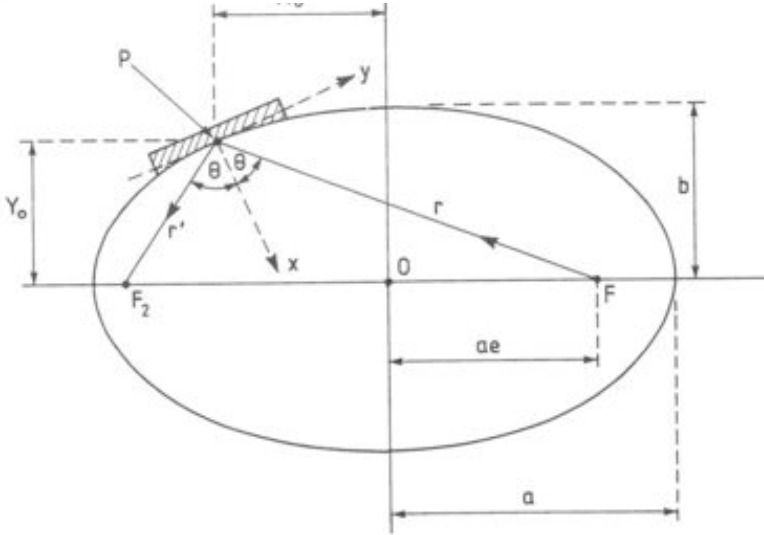
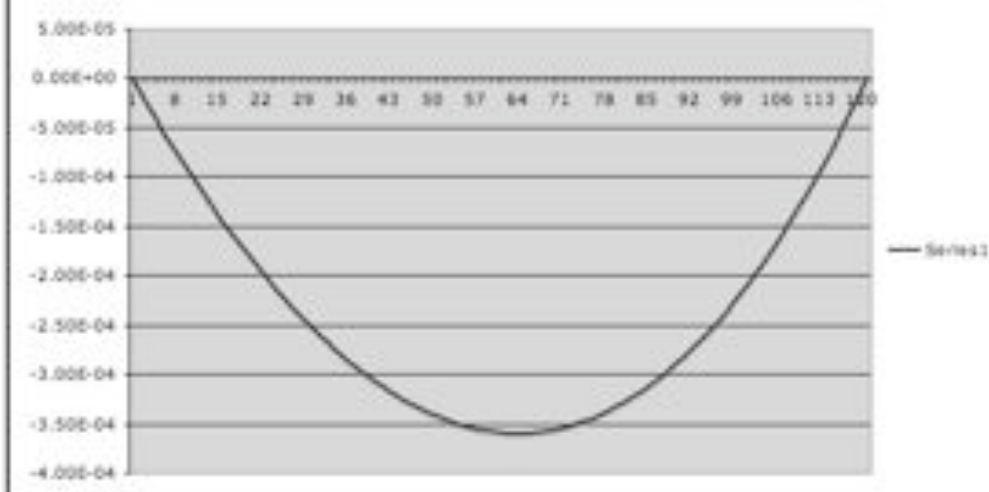
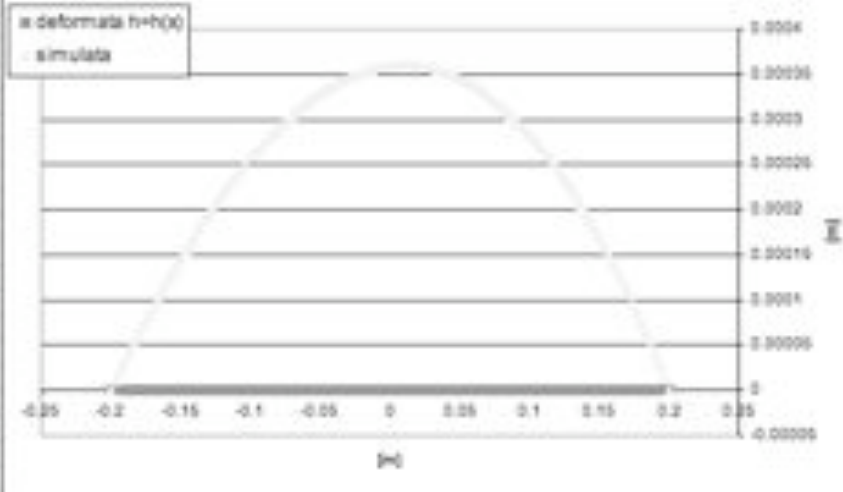

Two unequal moment applied at the edges

Correction by polishing

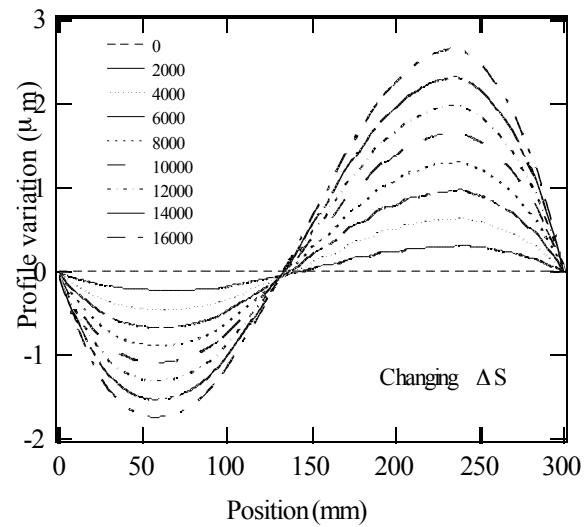
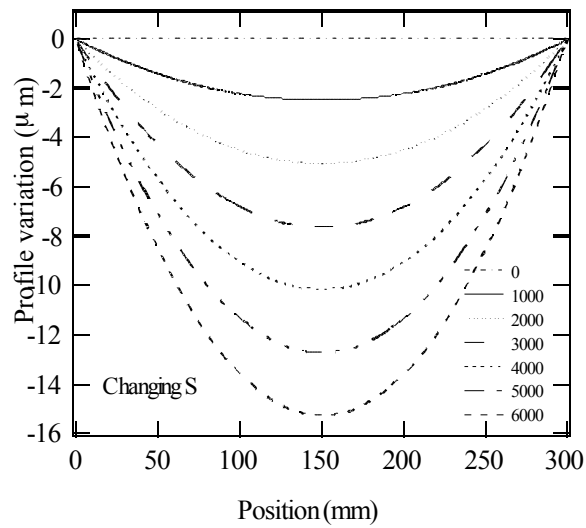
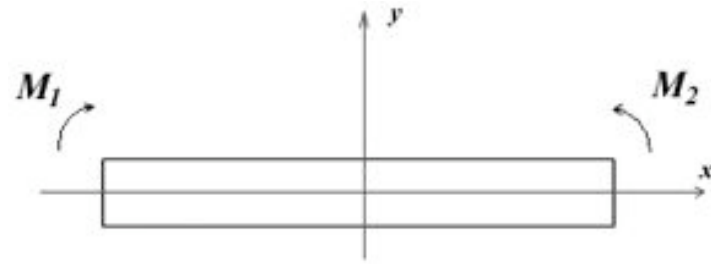

Correction by polishing

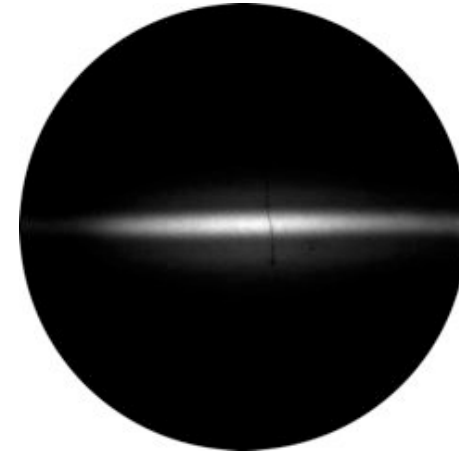

Sample tilted by 76°

$2 \times 7 \mu\text{m}^2$

Flux 1×10^{13} ph/sec

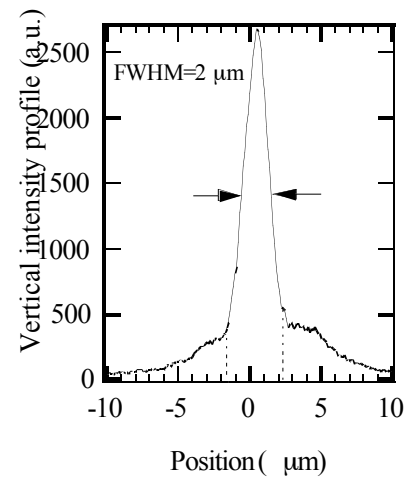
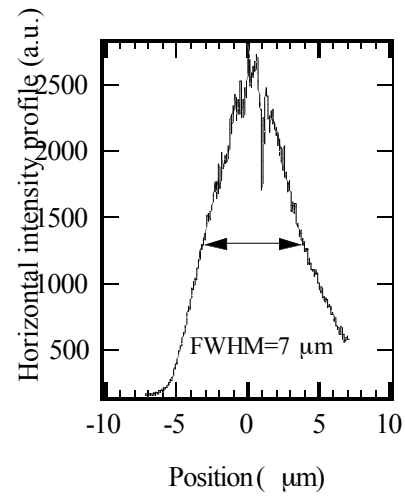

Corrected by variable width

micro-fluorescence & micro-diffraction (HXR)

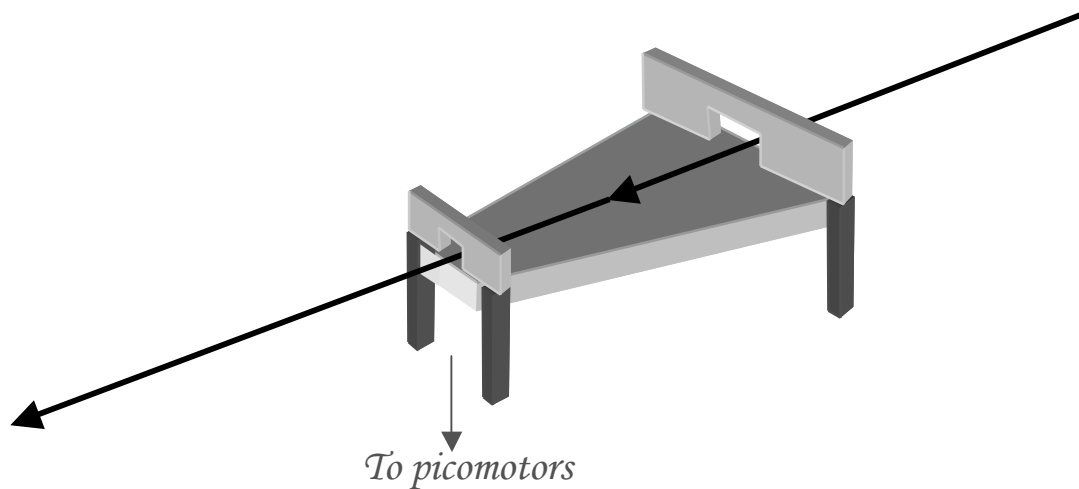

Bending system

The mirror must be shaped according to the required working distance and angle of incidence constant thickness but linear width variation.

Open clamping system to let the beam pass trough

Picomotors for the bending driving system (2 for each mirror)

Two different moments are applied at the end of the flat polished substrate

Corrected by variable width

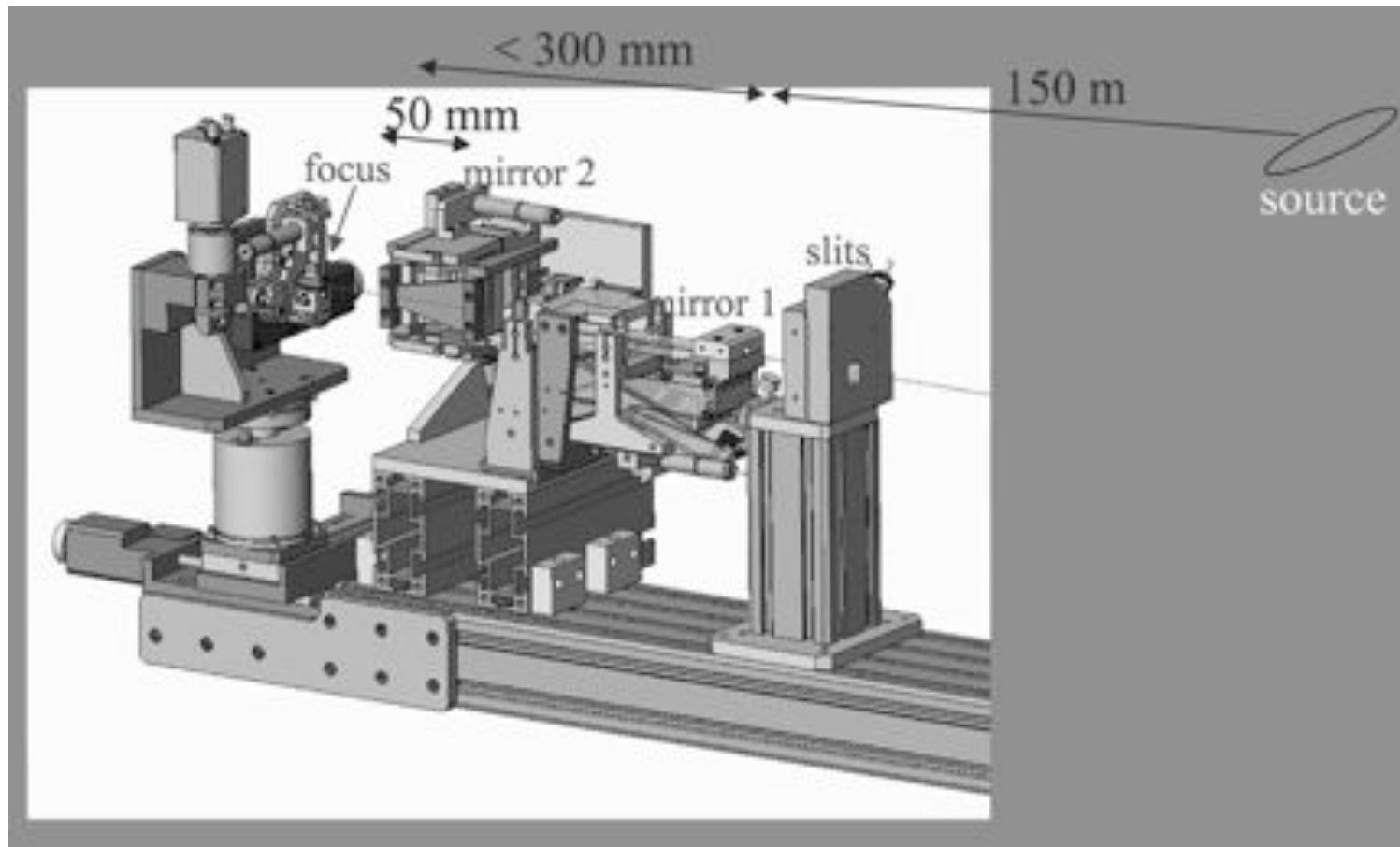

Corrected by variable width

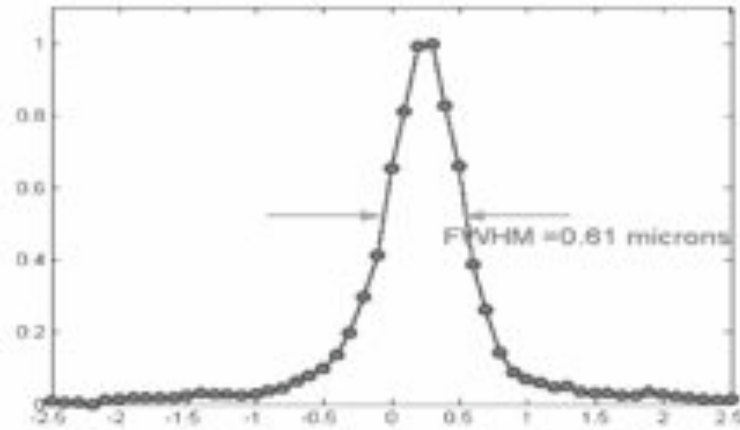

Vertical scan

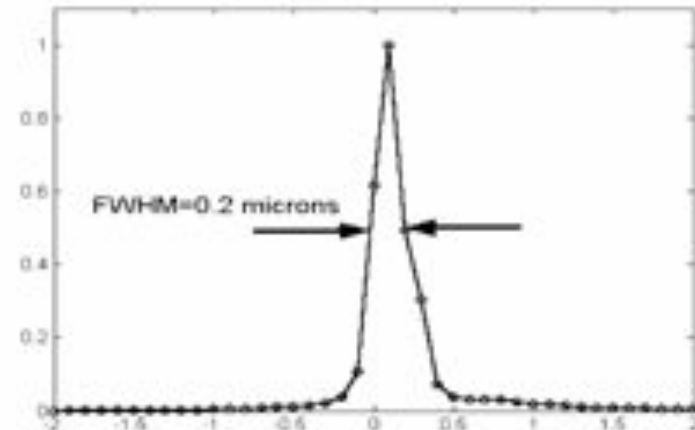

Horizontal scan

2001 **Beamline: ID 19**
Energy 19 KeV
Gain $3.5 \cdot 10^5$

Hybrid systems

Higher order corrected by:
Dynamic variation of the moment of Inertia
Correction of low frequency shape errors

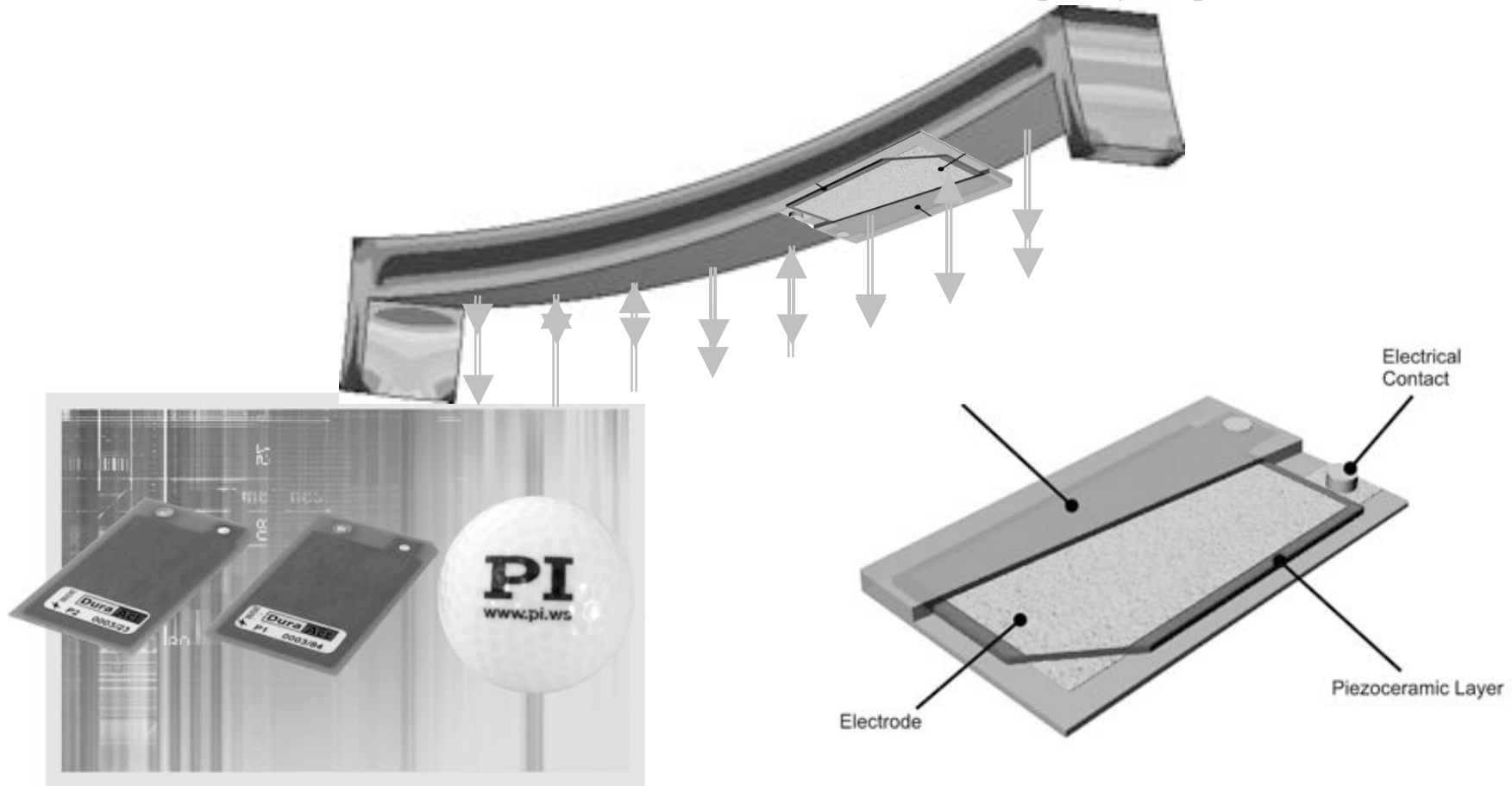

Hybrid Systems

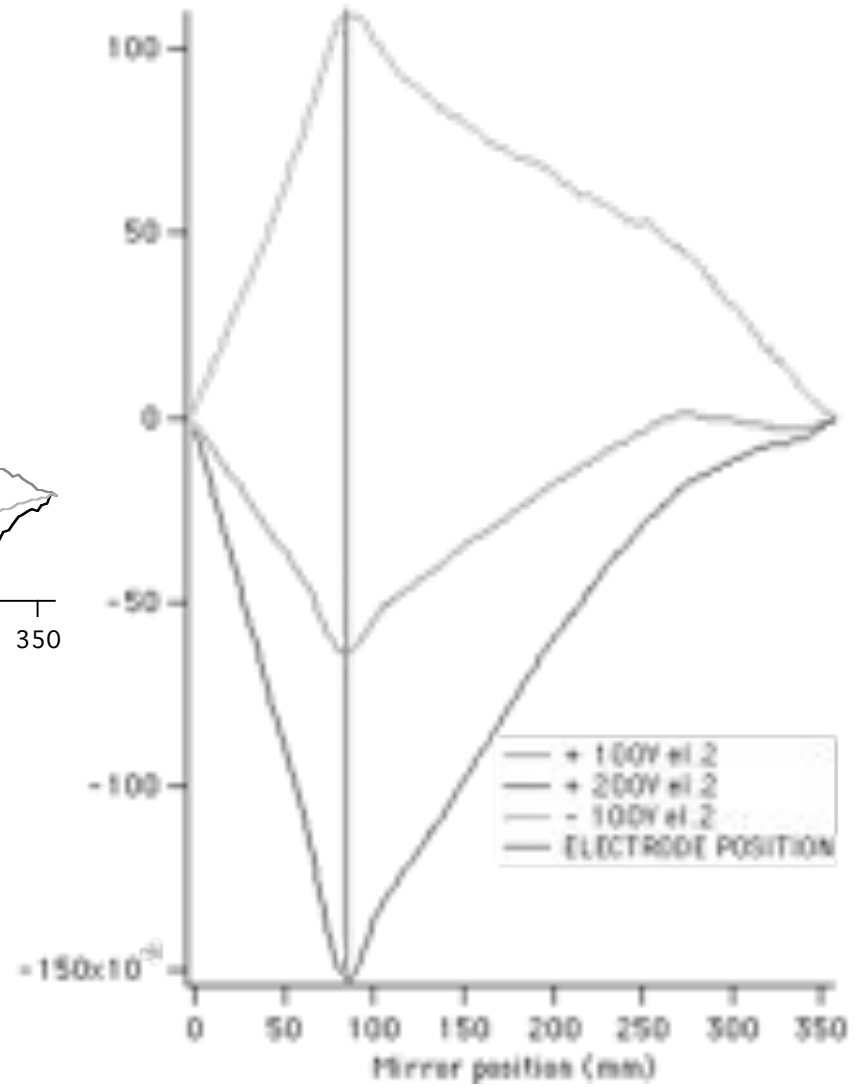
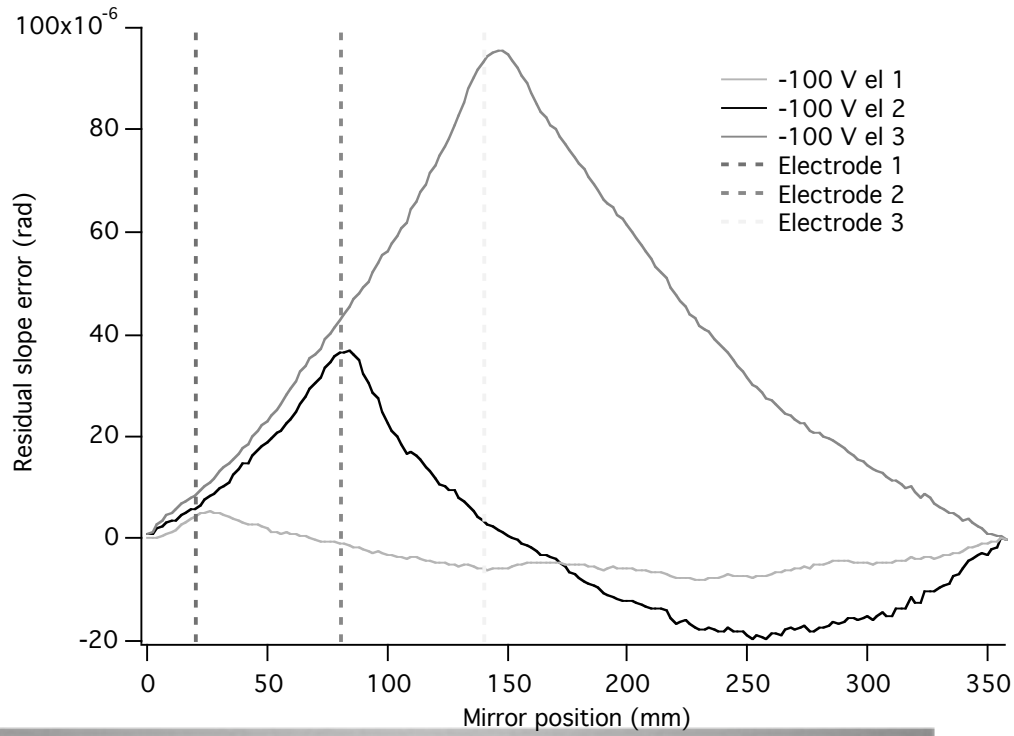

Larger dynamical range

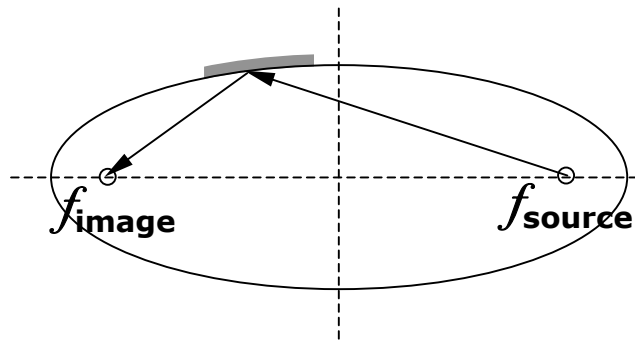

From flat to less than 1 m
image distance
Angle of incidence above 2°

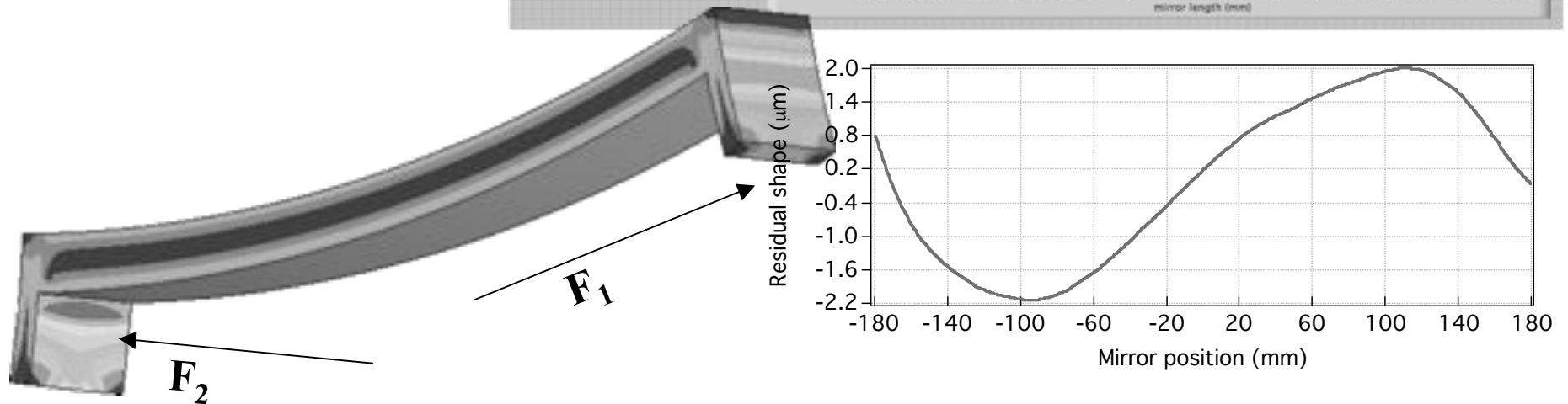
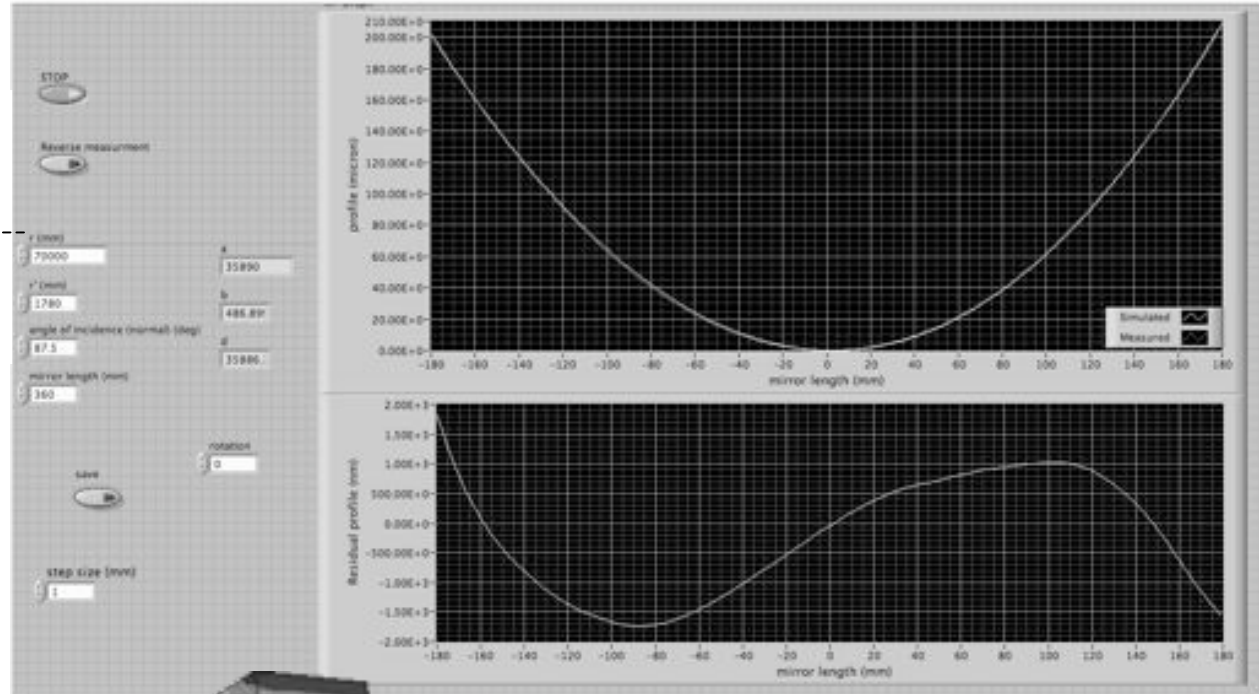

Other systems (larger dynamical range)

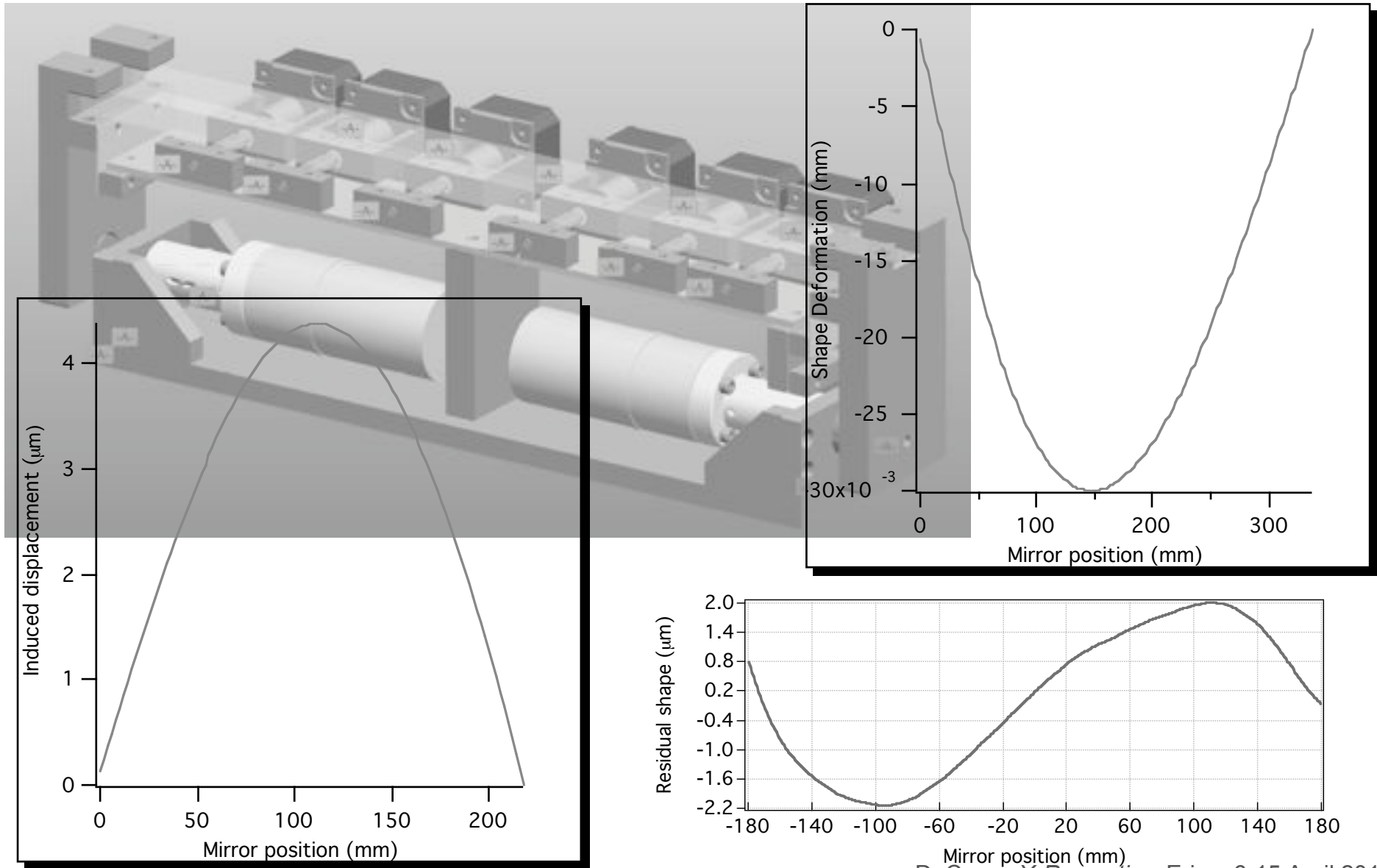

Bimorph mirrors

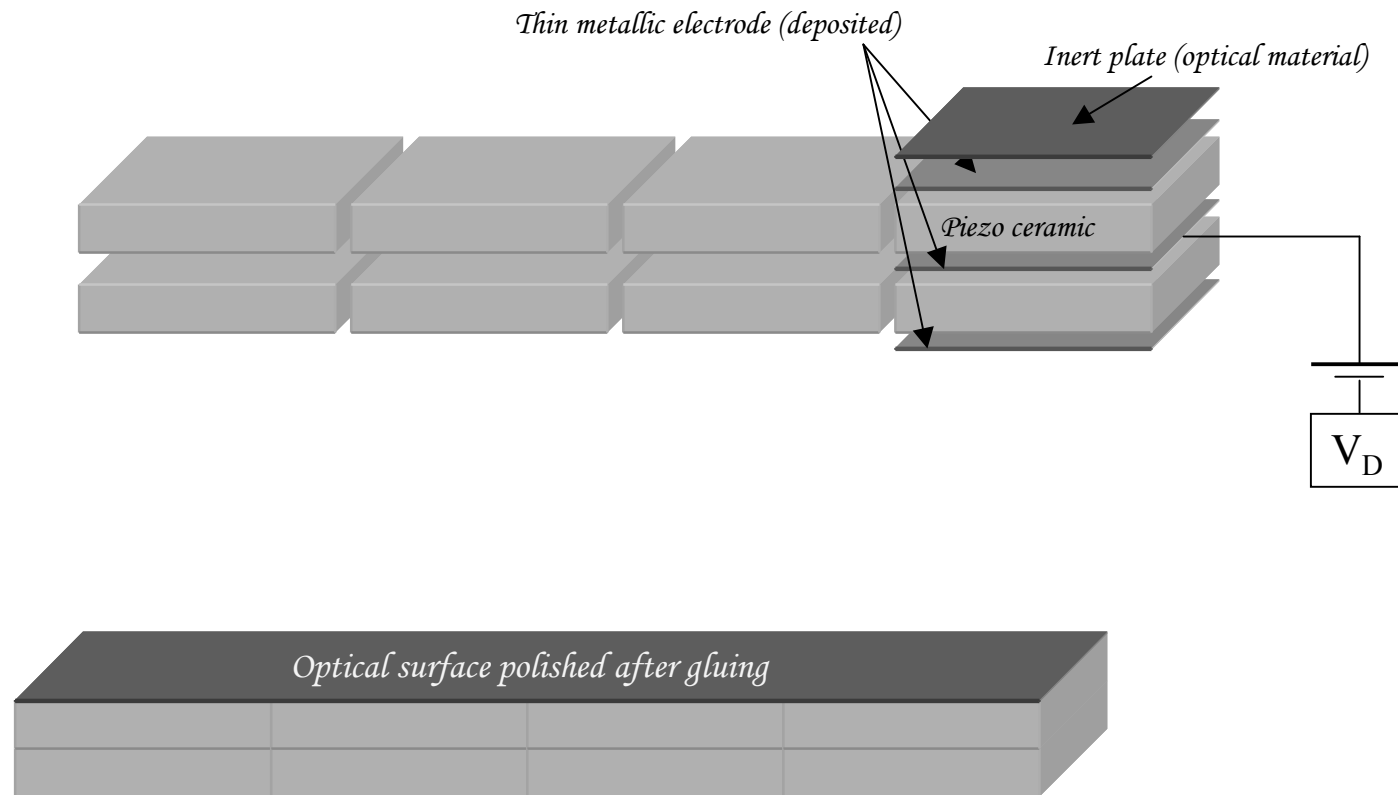

Bimorph mirrors

Dimension: from 150 mm (single element) to 1400 mm.

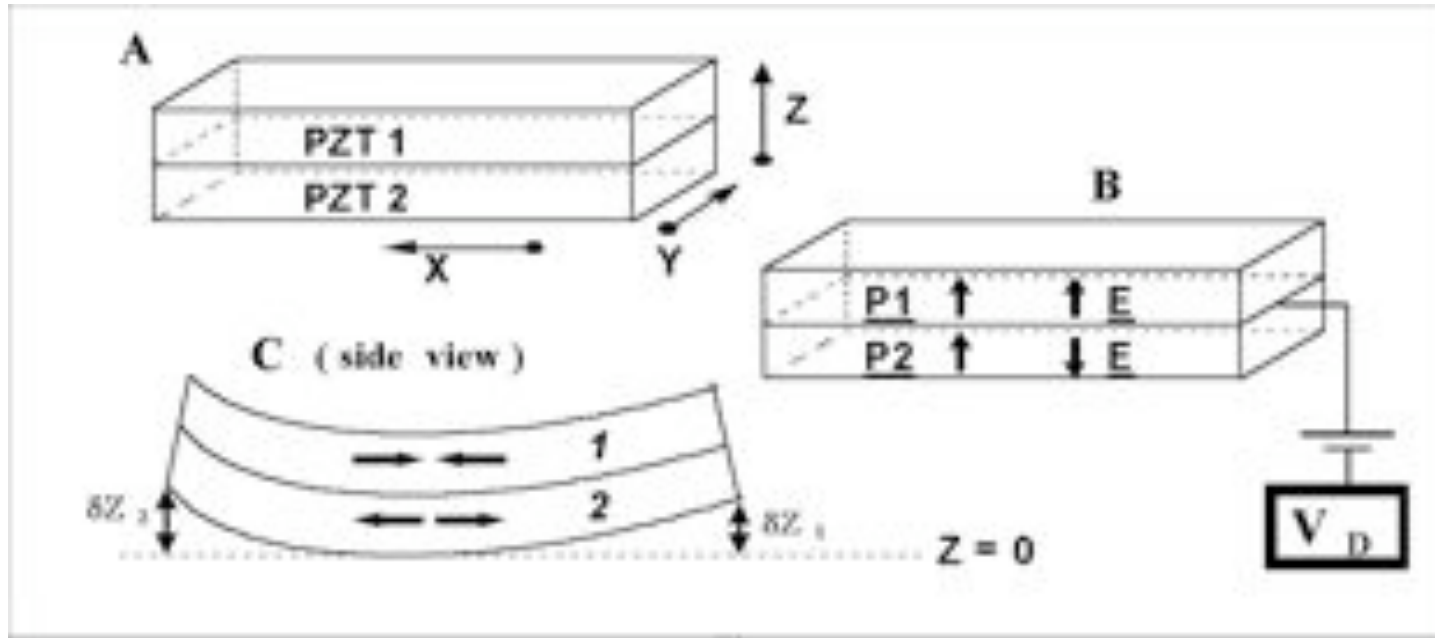

Radius variation: 370 m (+1500V) to 2300 m (-1500V)

Stability: $\Delta R/R \approx 0.8\%$ on 1 day scale
 $\Delta R/R \approx 2.0\%$ on 10 day scale

Bimorph mirrors

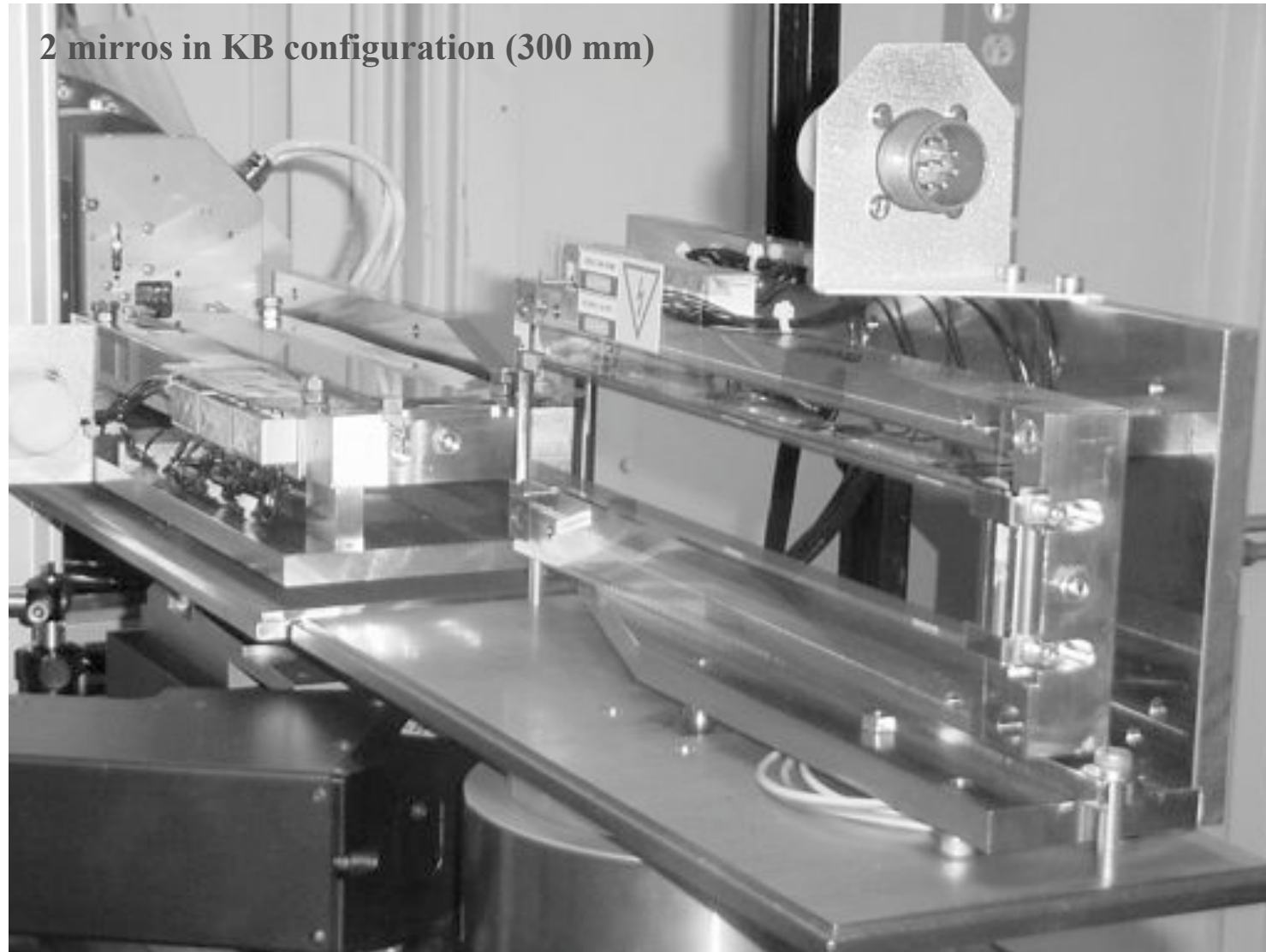

Bimorph mirrors

Photon Energy	33.167 KeV
Grazing angle	2 mrad
Coating	Pt
Source size	510 X 30 μm^2
Footprint	260 mm
VFM Demag	40
HFM Demag	62
Spot dimension	8.5 X 6.0 μm^2

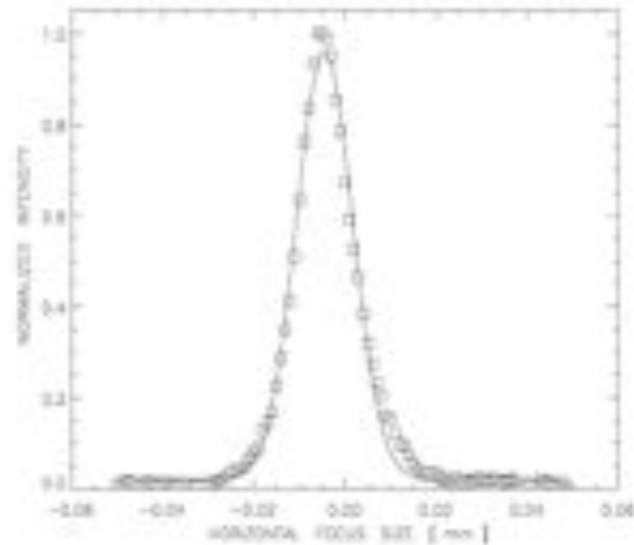
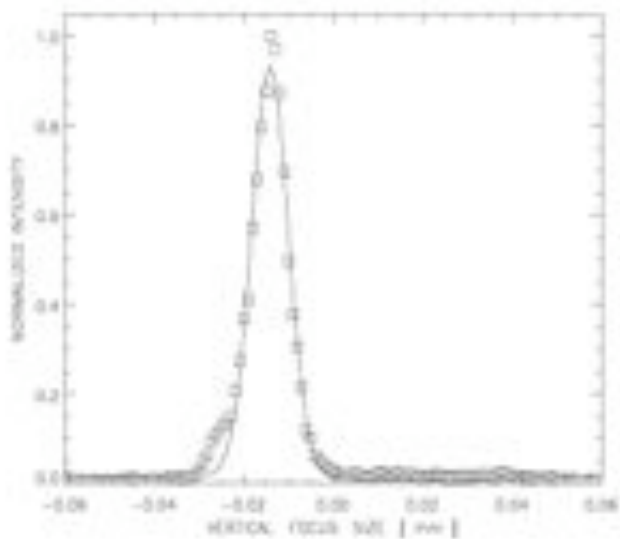
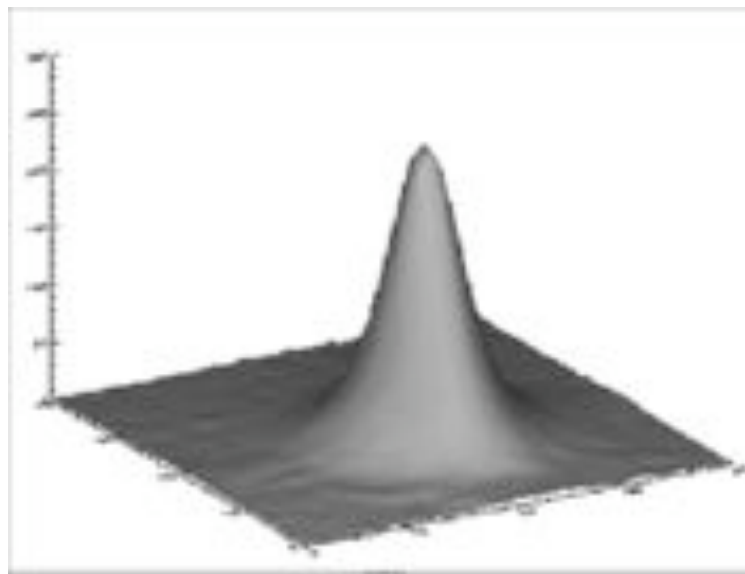

Small spot comparison

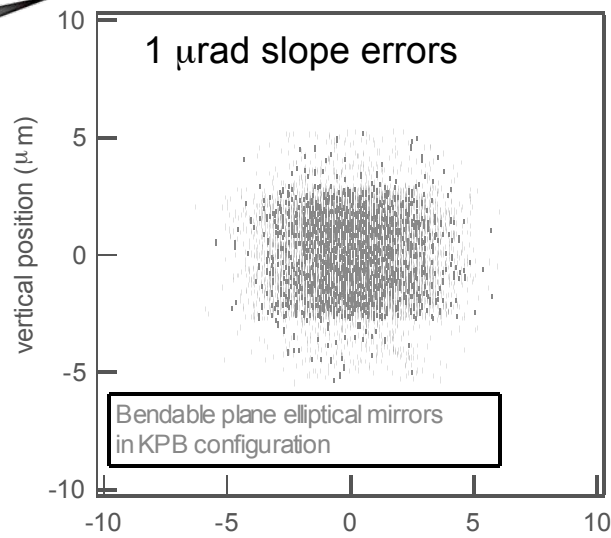
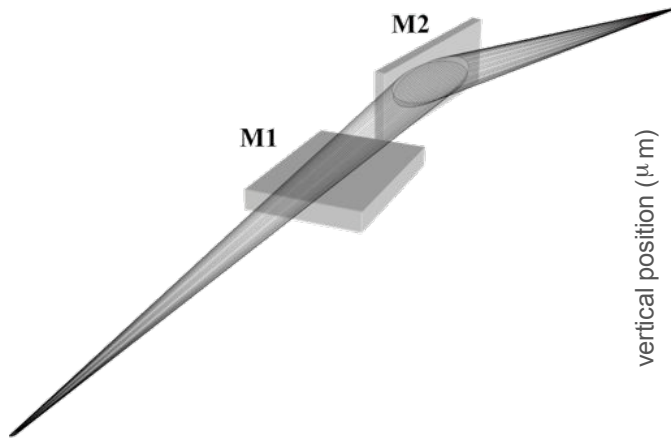

The only way to have a real micro-focus is to start from a flat or spherical surface and bent it to an mono dimensional ellipse

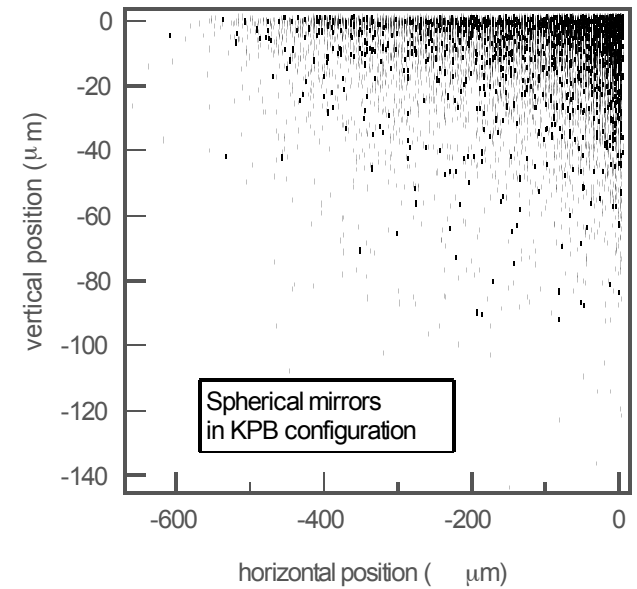
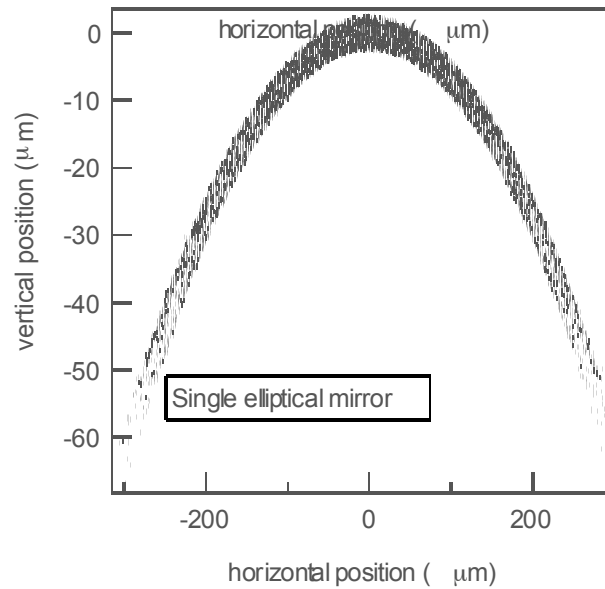
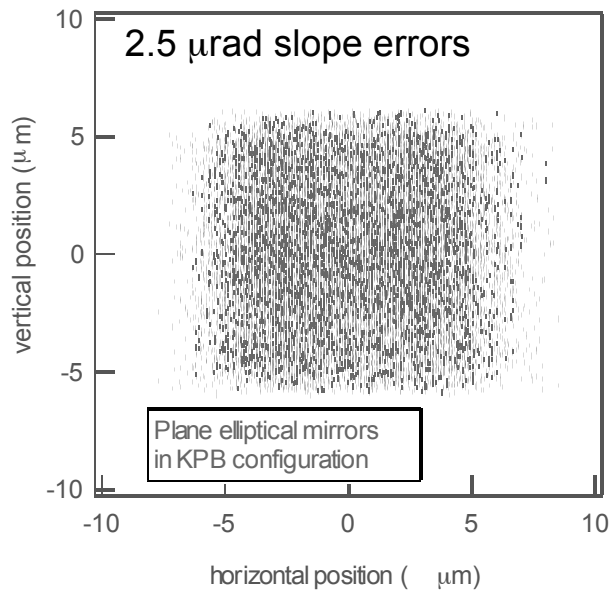

Out of focus

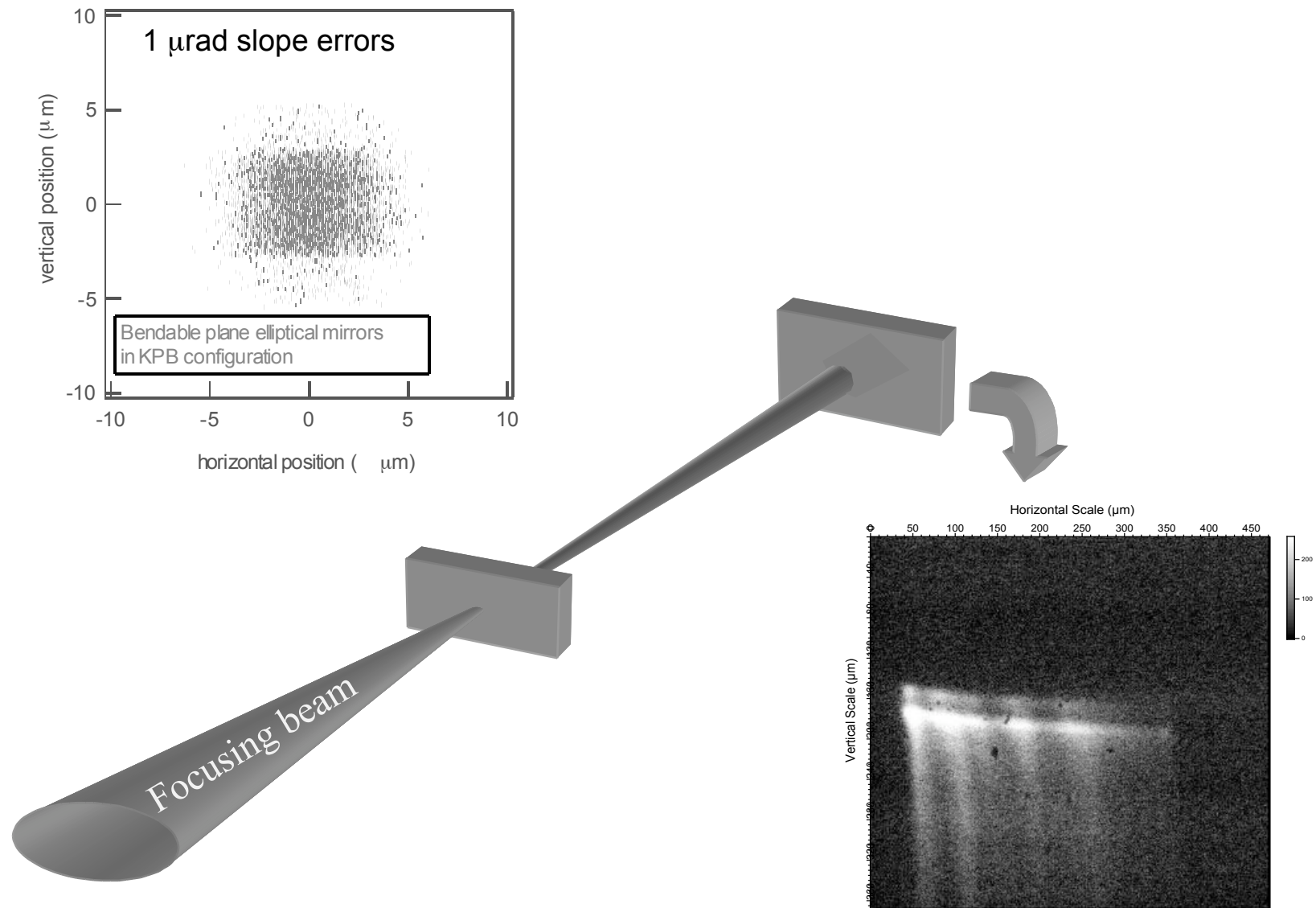

Out of focus

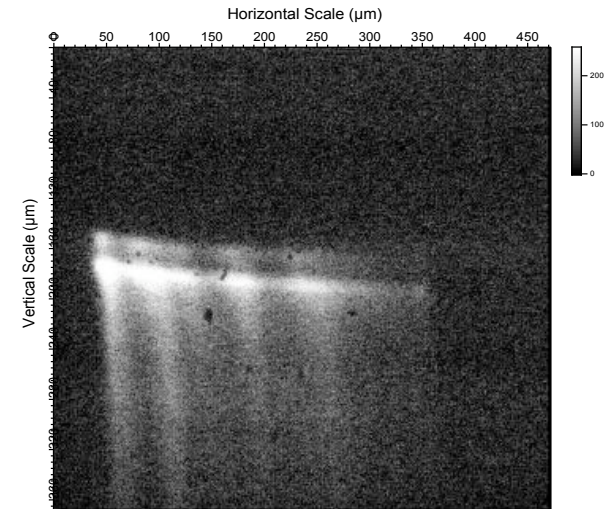
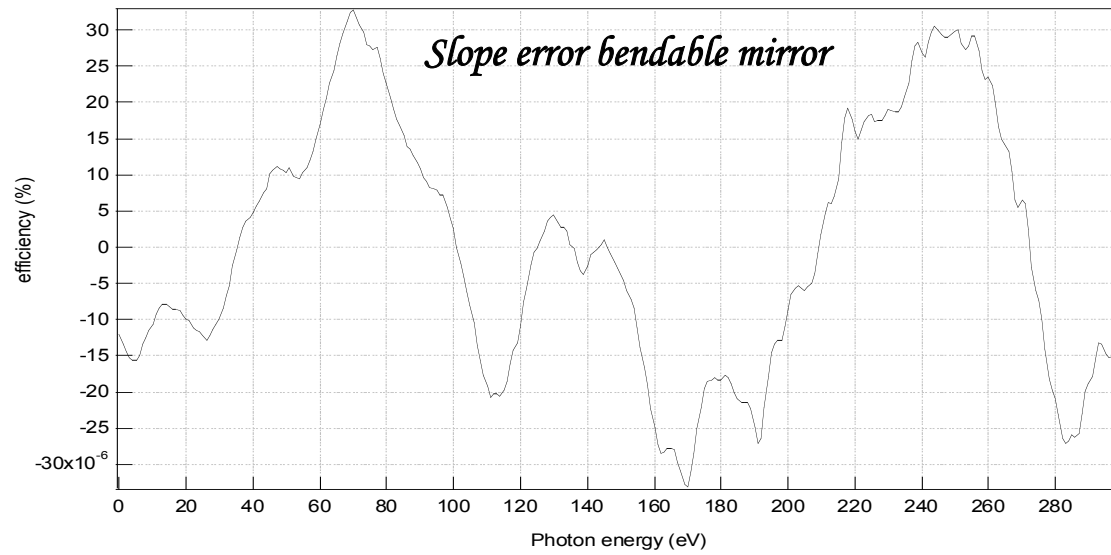
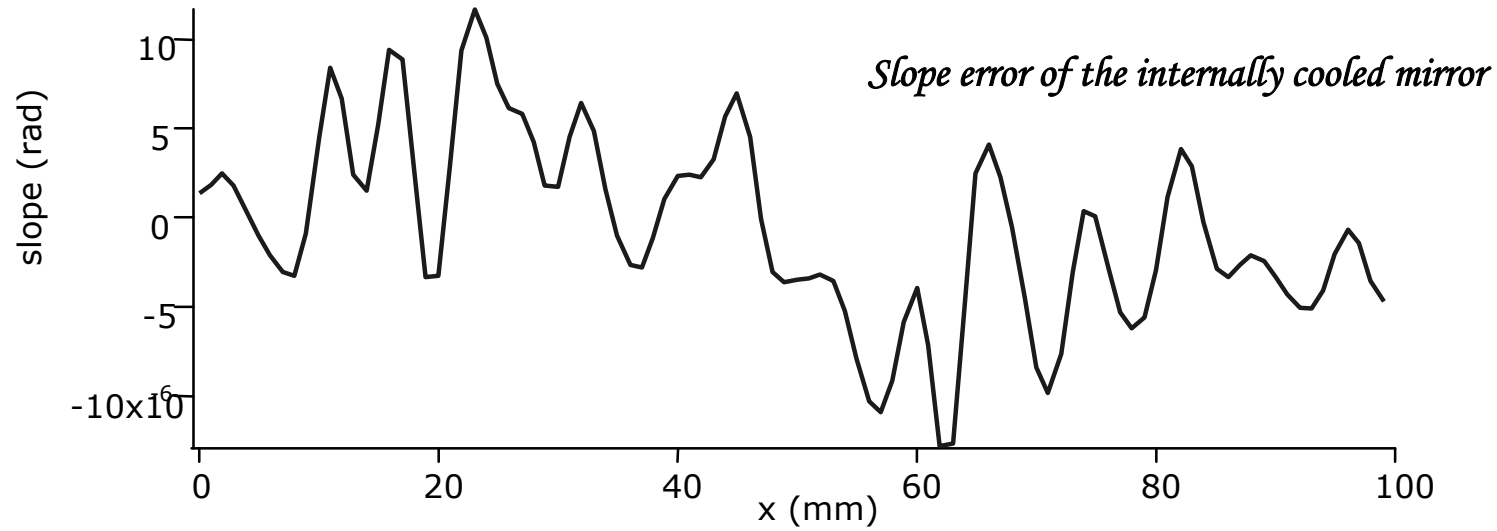

Out of focus

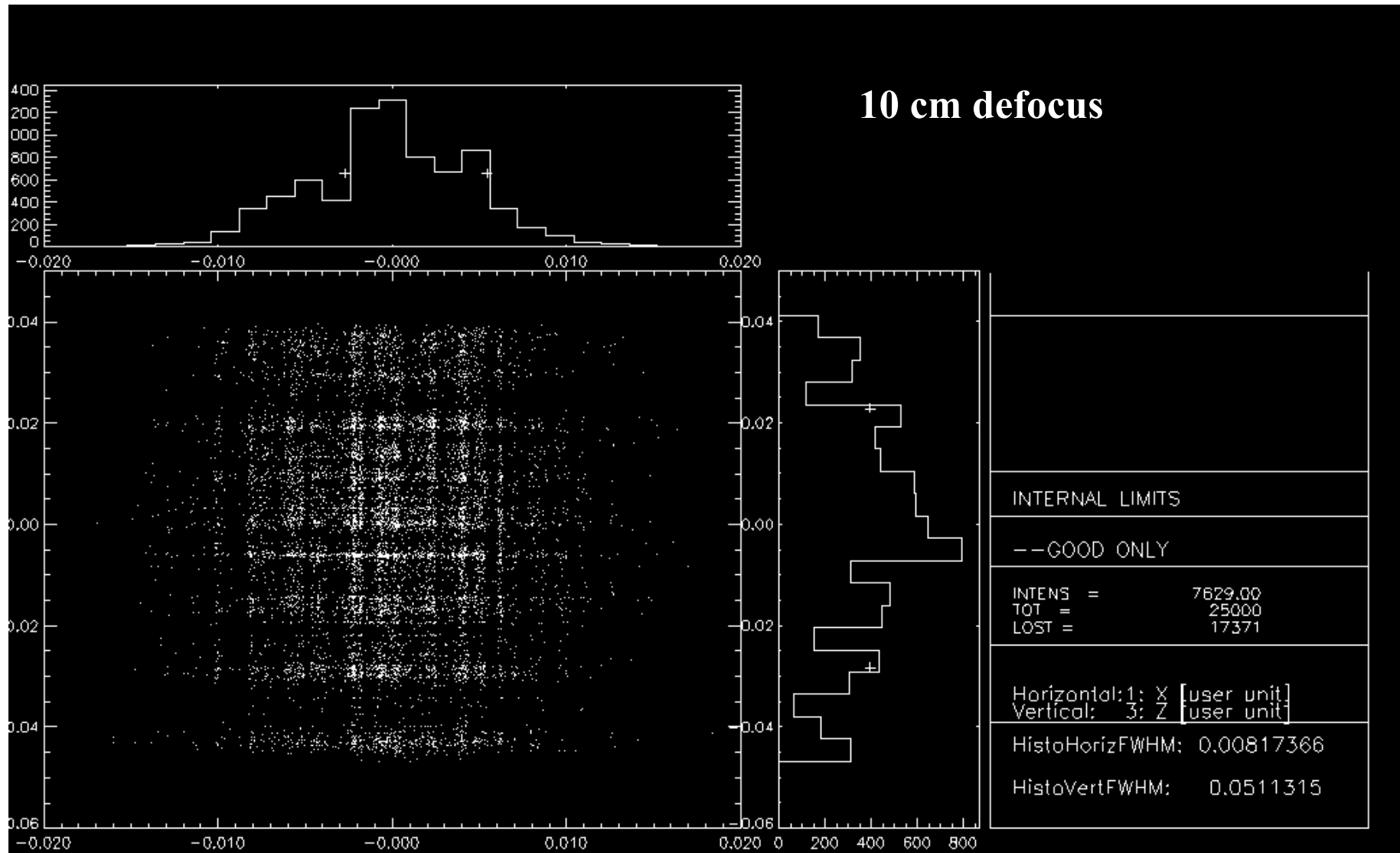

Different mirror materials

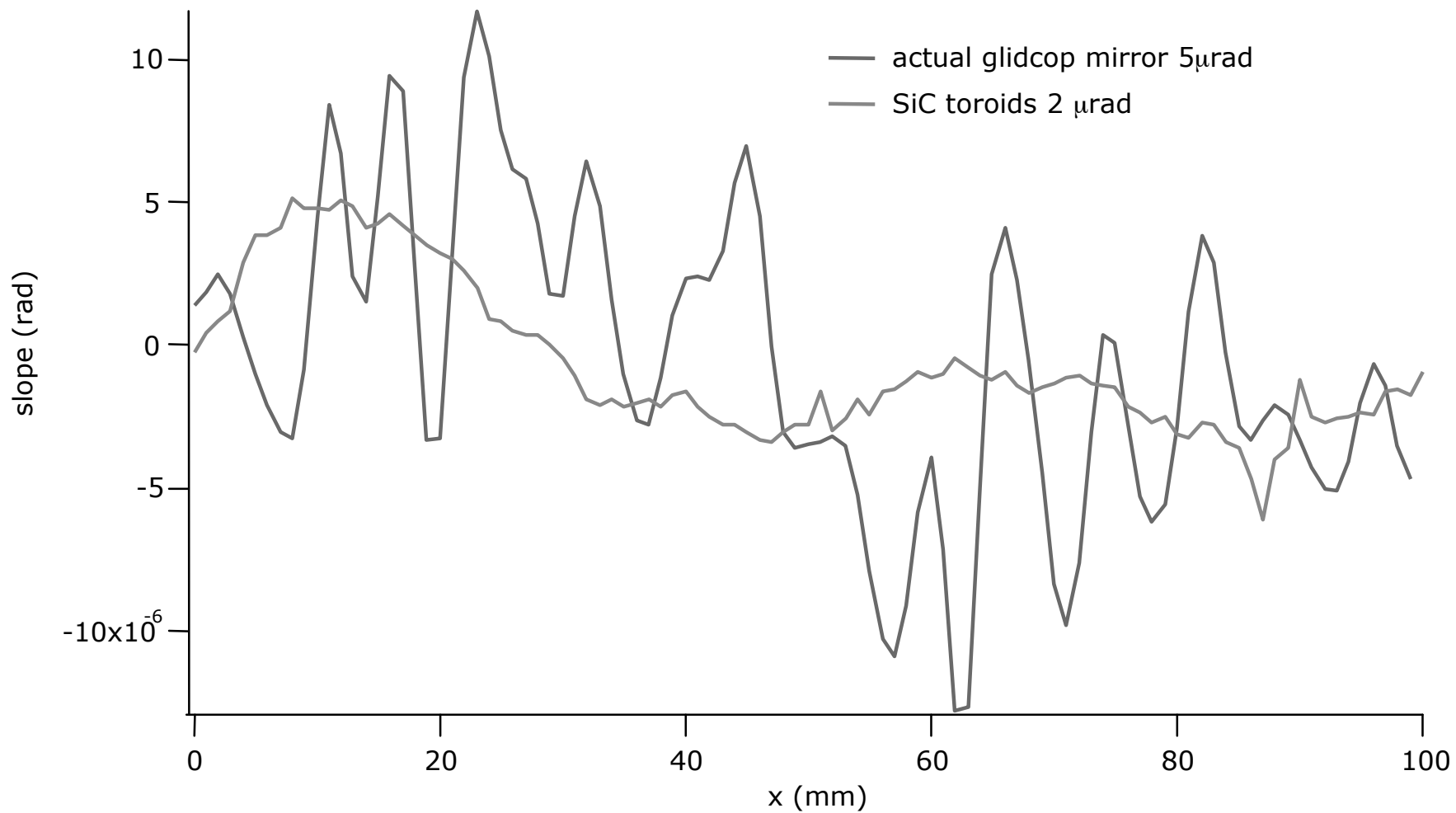

Out of focus with Silicon mirrors

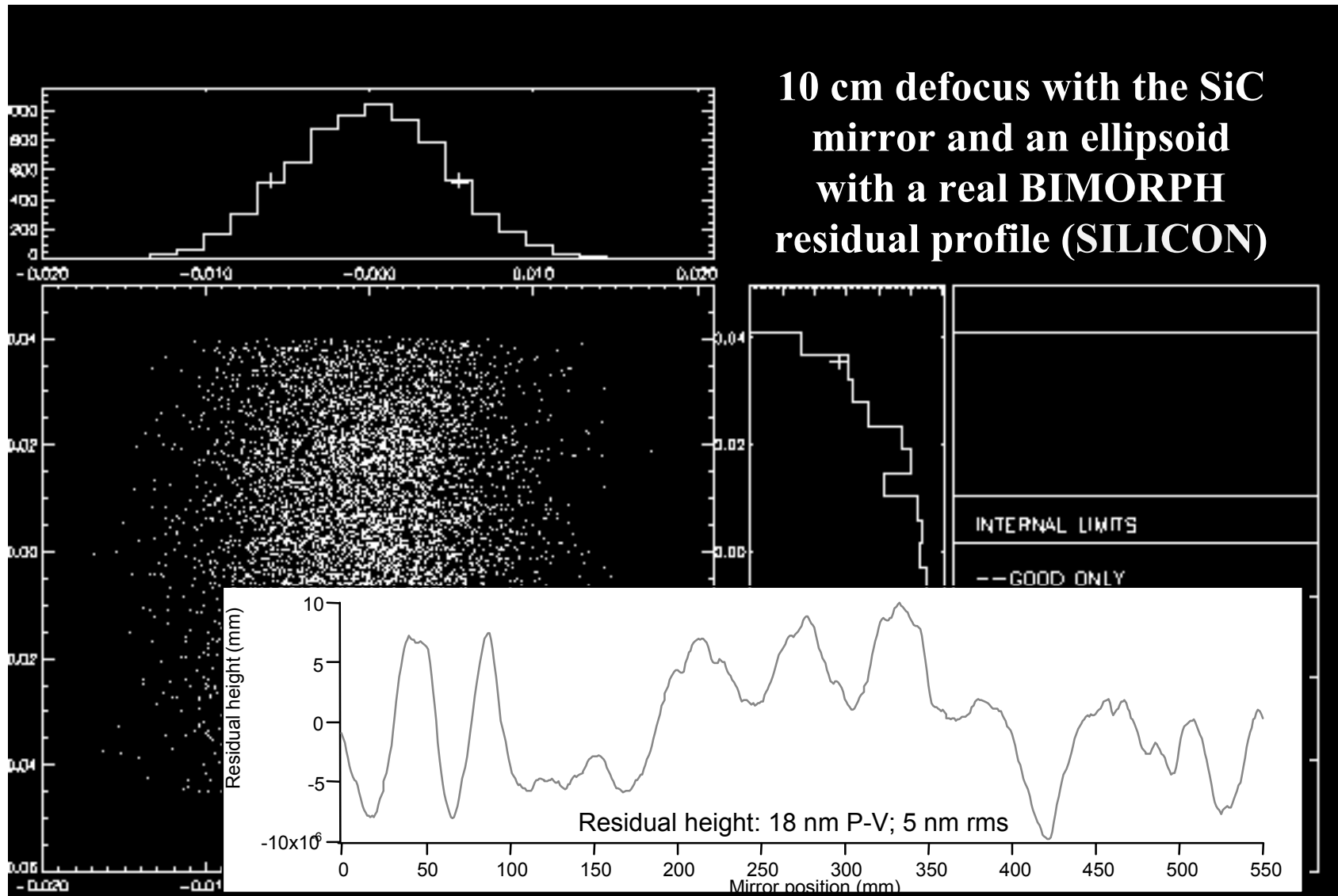

The bimorph mirror is property of GM/CA CAT at the APS (funded in whole or in part with Federal funds from the National Cancer Institute (Y1-CO-1020) and the National Institute of General Medical Science (Y1-GM-1104)). ACCEL instruments GmbH is the main contractor for the realization of the GM/CA CAT beamlines.

Metallic vs Silicon

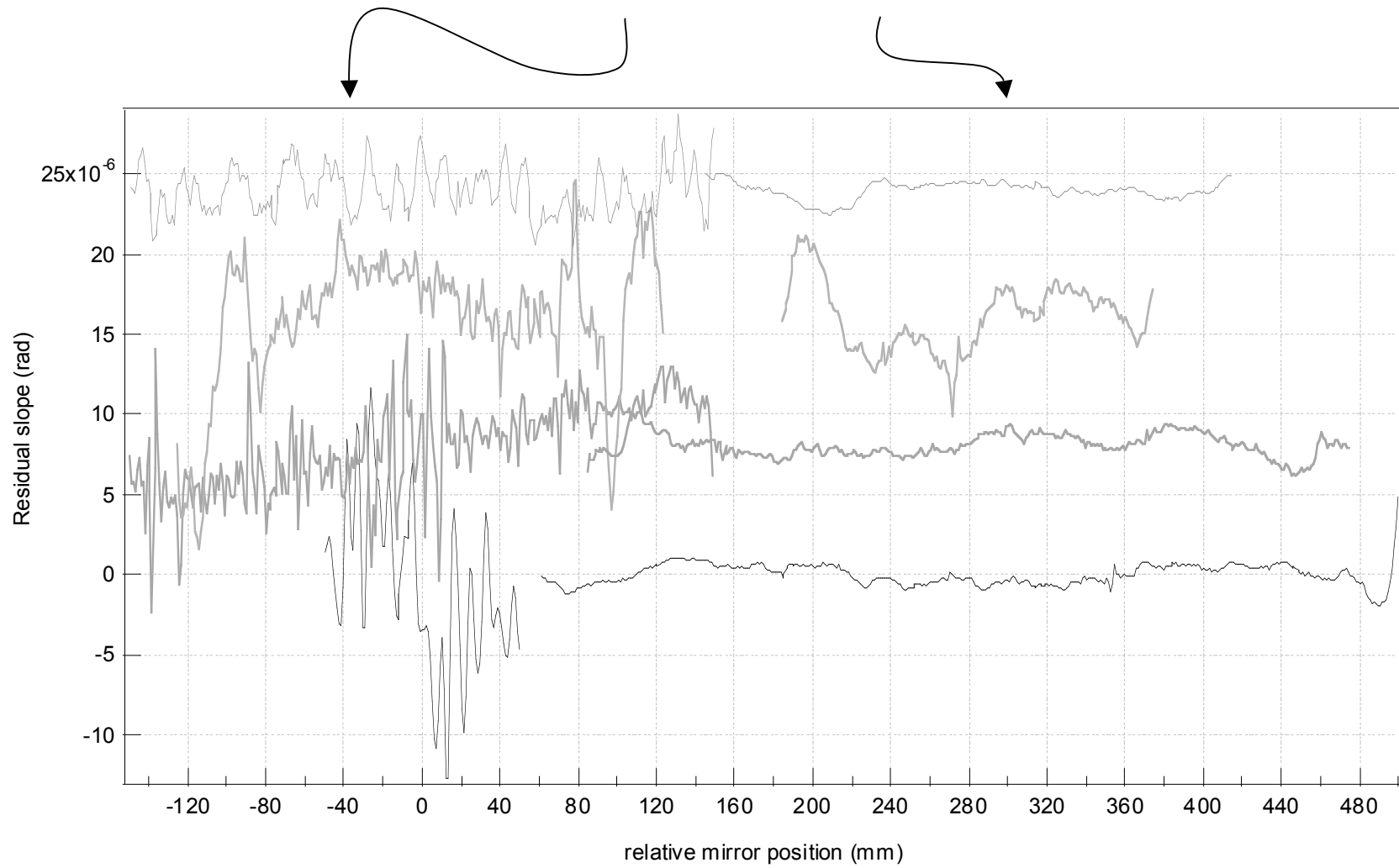

Wavefront / Coherence

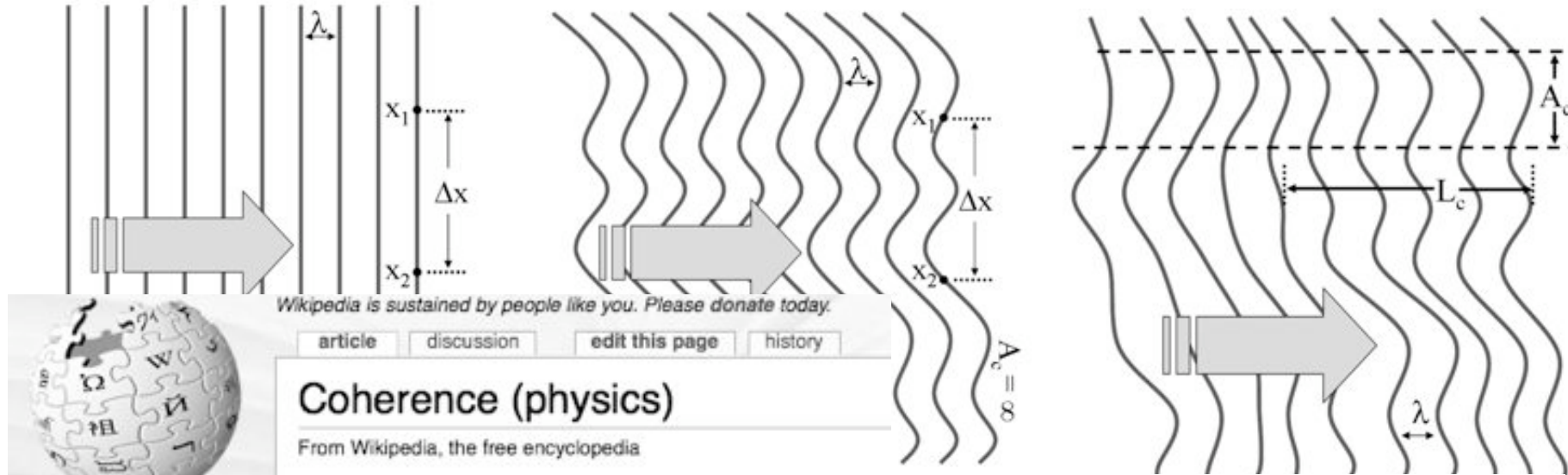

Wikipedia is sustained by people like you. Please donate today.

article discussion edit this page history

Coherence (physics)

From Wikipedia, the free encyclopedia

In physics, coherence is a property of waves, that enables stationary (i.e. temporally and spatially constant) interference. More generally, coherence describes all correlation properties between physical quantities of a wave.

Coherence

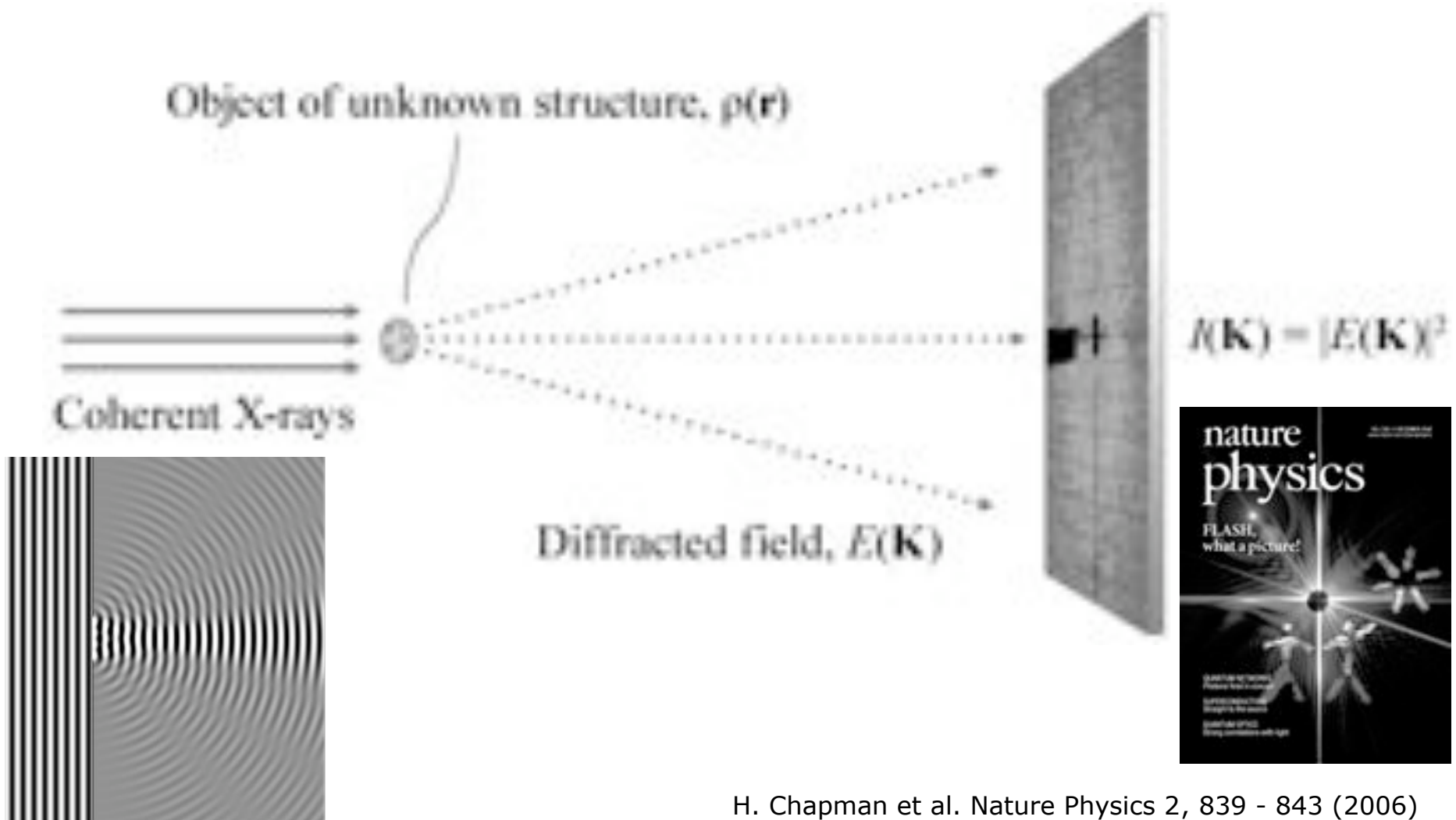

H. Chapman et al. Nature Physics 2, 839 - 843 (2006)

Coherence & Wave front Preservation

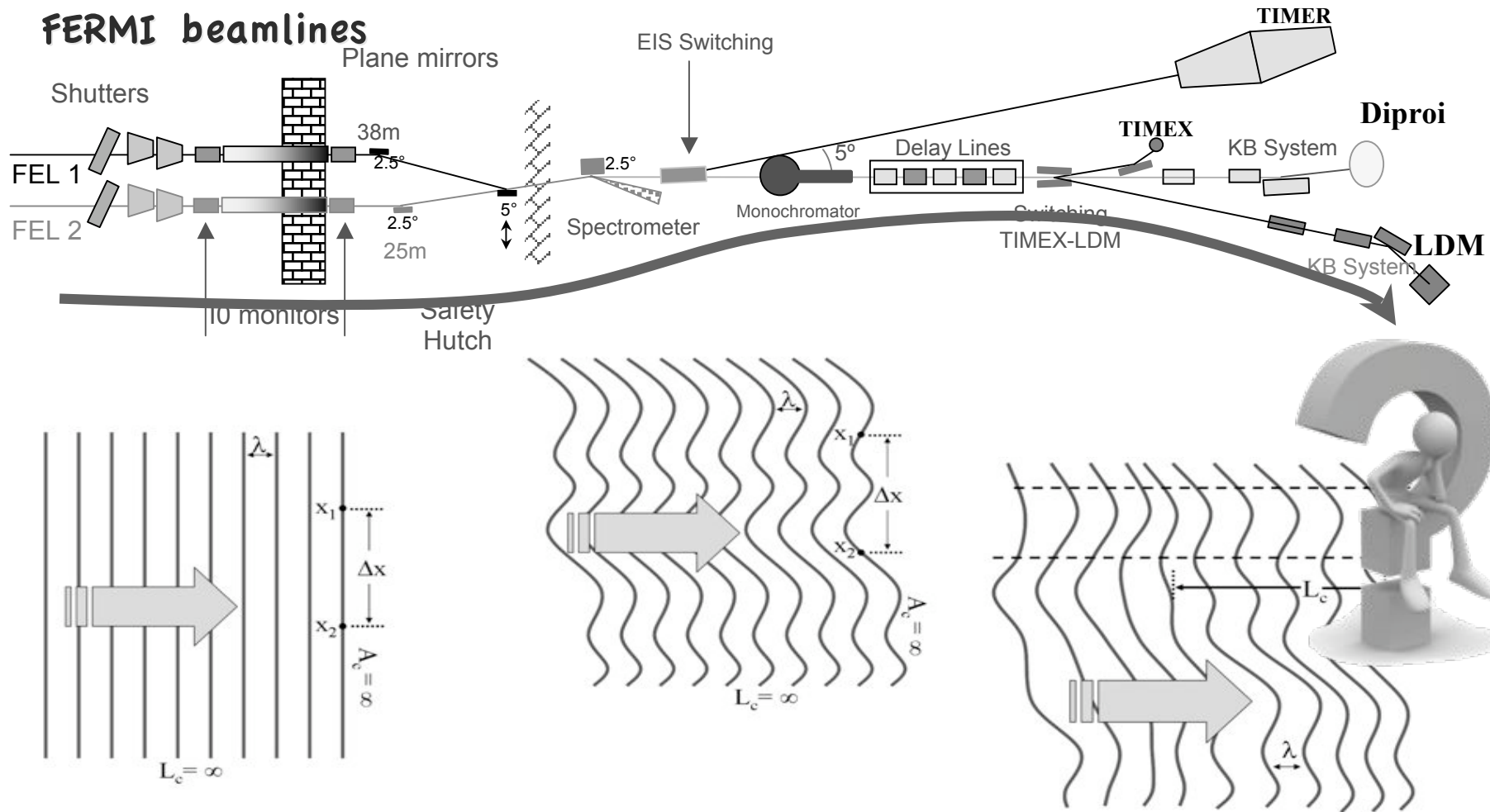

Coherence & Wave front preservation

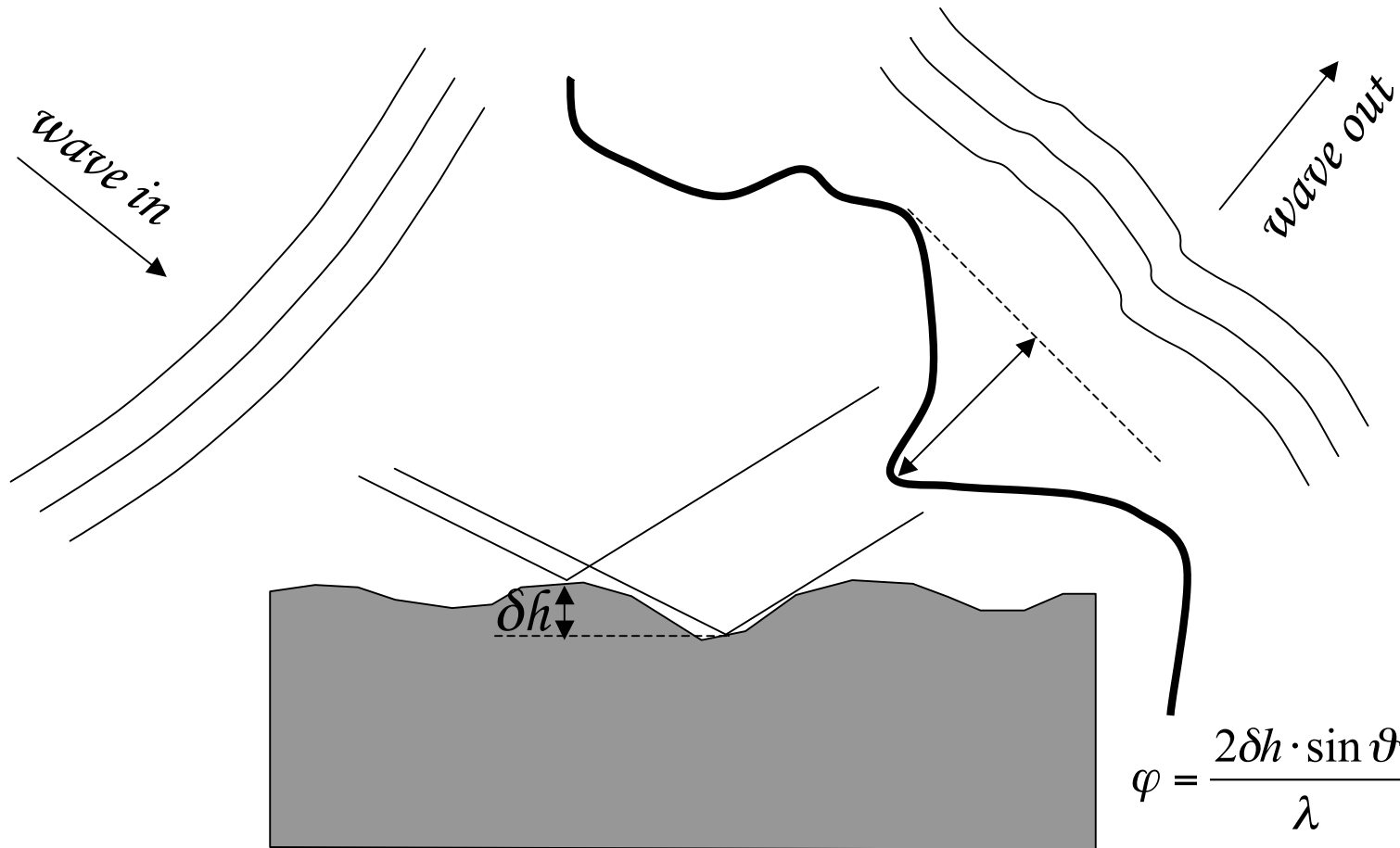

$\lambda/4$ deformation (after all mirrors) needed
 $\lambda/10$ deformation (at each mirrors) accepted

Coherence & wave front preservation

Fermi@elettra case			
Wavelength	Angle of incidence	shape error p-v $\varphi = 0.25$	shape error p-v $\varphi = 0.1$
40 nm	6°	47	18
40 nm	3°	95	38
40 nm	1.5°	191	76
10 nm	3°	23	9
10 nm	2°	35	14
10 nm	1°	71	28
5 nm	3°	12	5
5 nm	2°	18	7.2
5 nm	1°	36	14
1.67 nm	3°	4	2

Xfel(s) case			
Wavelength	Angle of incidence	shape error p-v $\varphi = 0.25$	shape error p-v $\varphi = 0.1$
1 nm	1°	7	3
0.5 nm	1°	3.6	1.4
0.1 nm	0.33°	2	<1

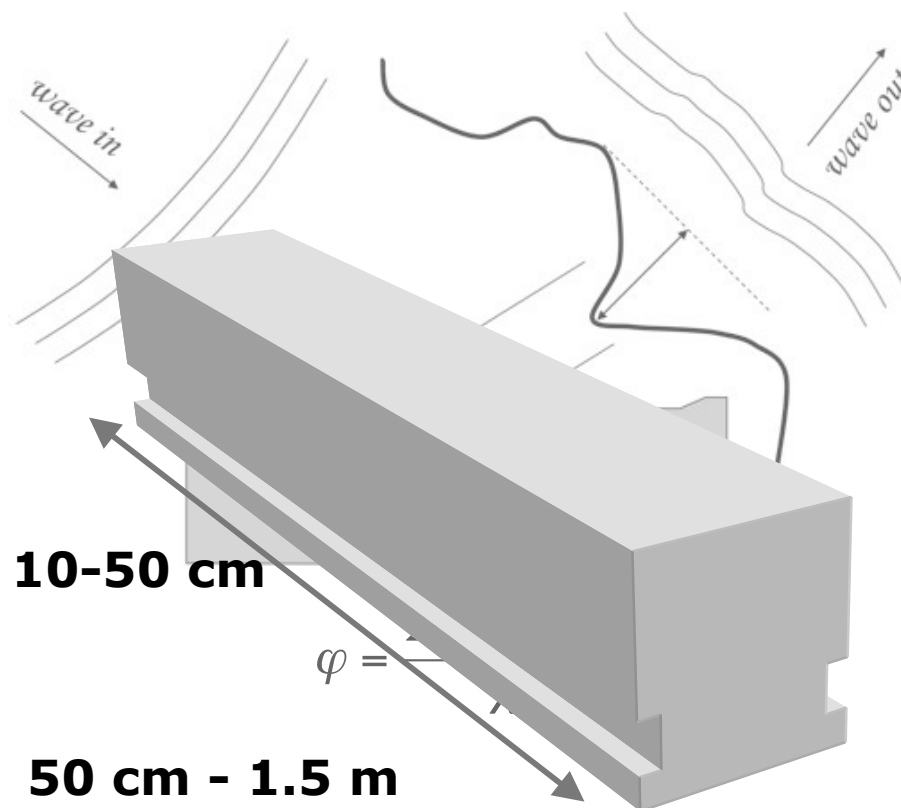

Mirror shape errors

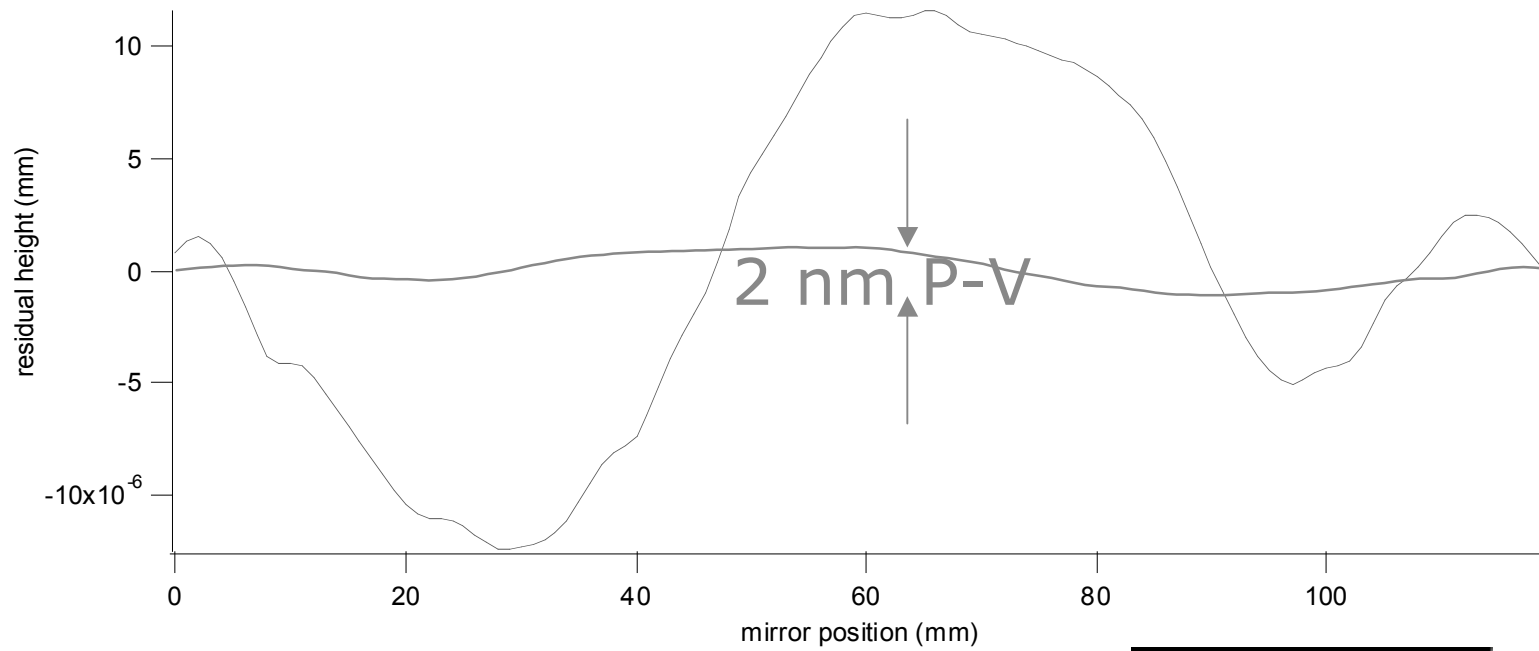

Typical SR mirrors

Required FEL mirrors

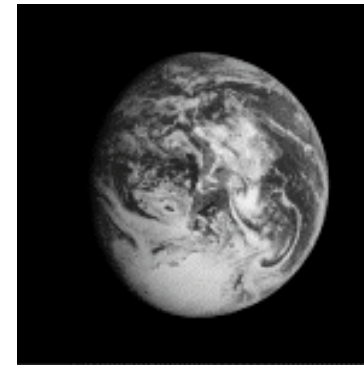

Mirror polishing

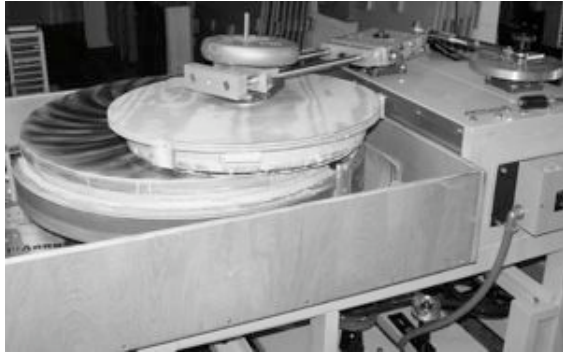

Classical polishing

- 1) Classical polishing (Computer Controlled Polishing-CCP)
- 2) High precision metrology (NOM-Bessy)
- 3) Ion Beam Figuring or CCP
- 4) Second iteration with metrology
- 5) Second IBF or CCP
- 6) Third.....
- 7)
- 8)

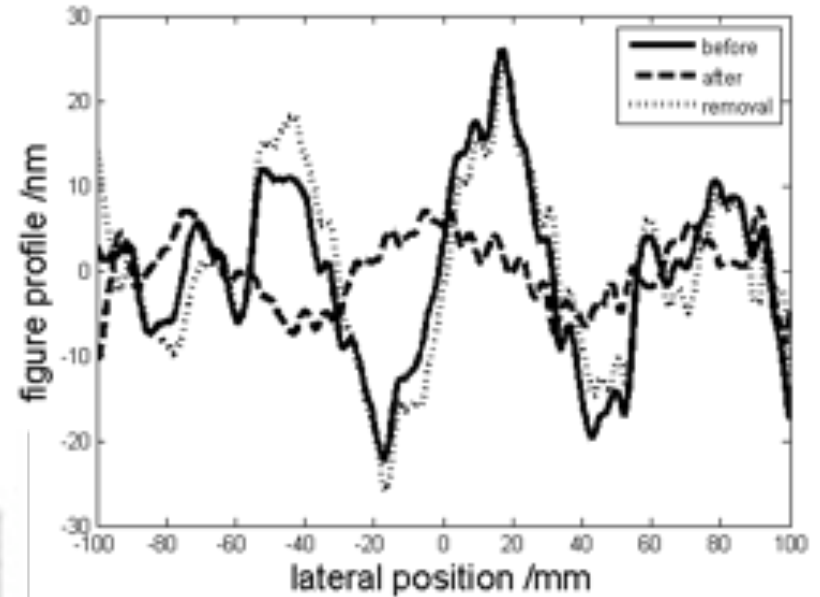
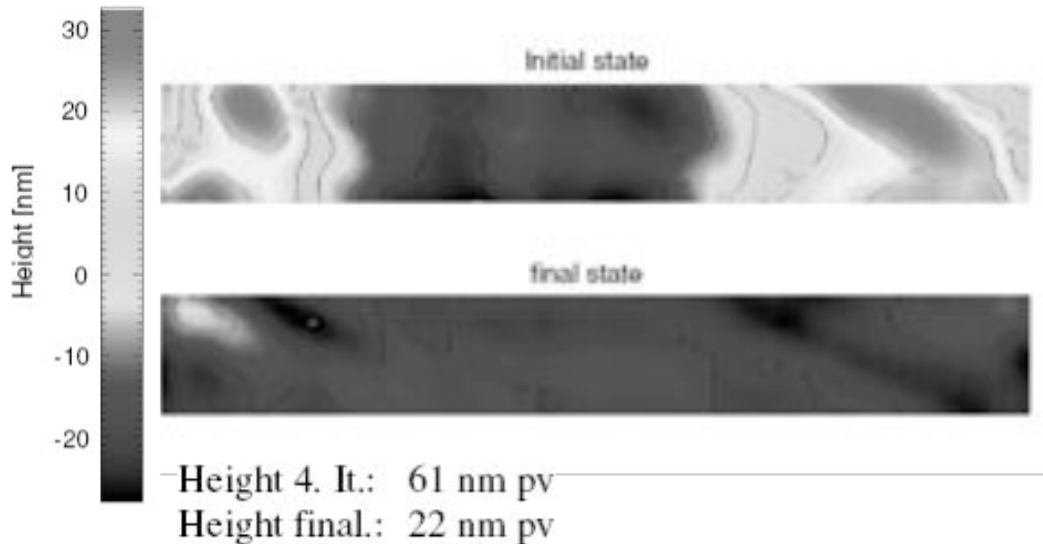

	PV /nm	RMS /nm	slope RMS /arcsec
before	48.4	10.3	0.37
after	14.9	3.9	0.22
after -0.5mm	13.9	3.6	0.17
after +0.5 mm	18.5	4.4	0.31

Preferential coating techniques

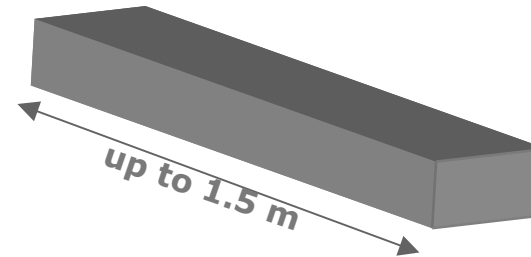
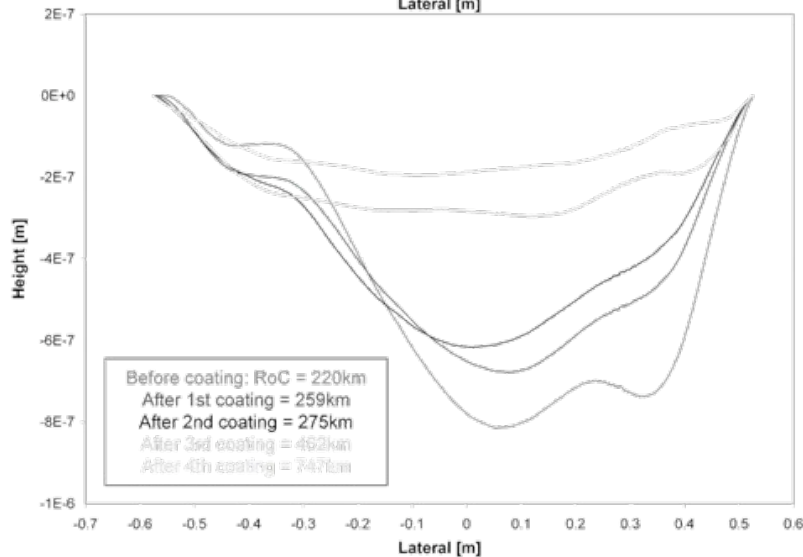
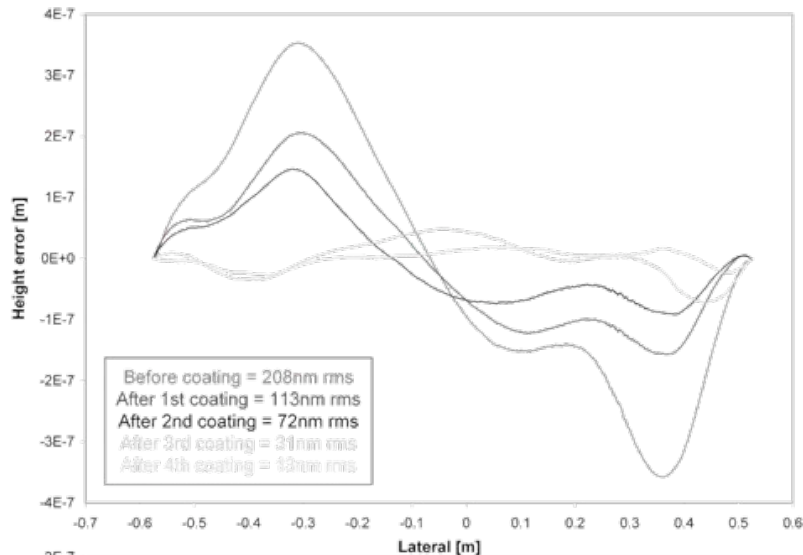

- 1) **Classical polishing**
- 2) **High precision metrology**
- 3) **Error correction by Rh controlled deposition**
- 4) **Second iteration with metrology**
- 5) **Second differential coating deposition**
- 6) **Third.....**
- 7) **.....**
- 8) **.....**
- 9) **.....**
- nn) **Final required slope/shape error reached (hopefully)**

Elastic emission machining

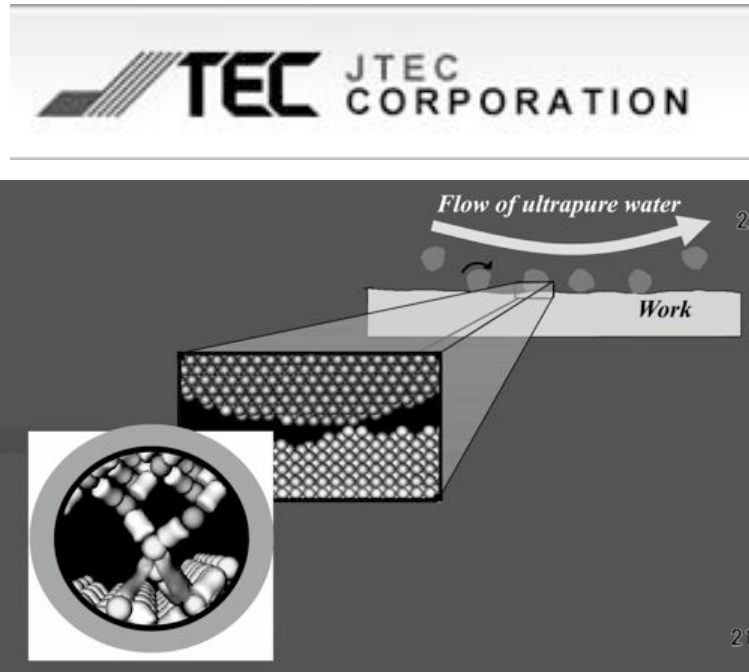

Chemical reaction are induced between top-site atoms of mirror and fine powders

Problem: max dimension 100mm (400 with lower precision)

mirror substrate : Quartz Glass Silicon

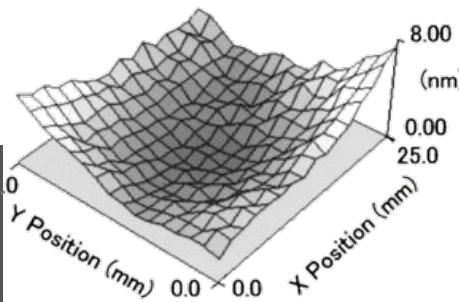

Before machining

1.3 nm rms

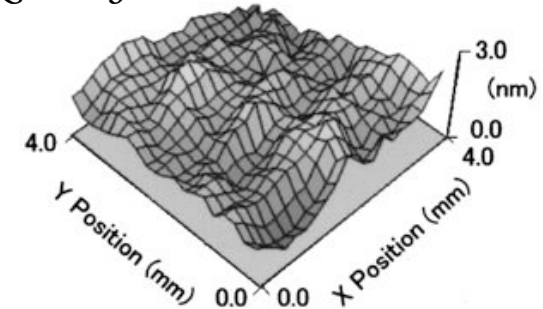

Before machining

0.32 nm rms

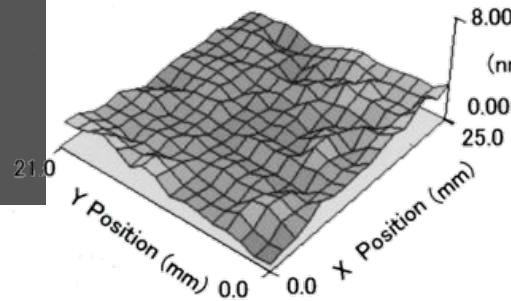

after machining

0.3 nm rms

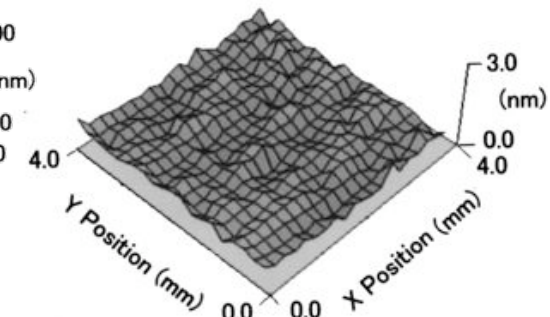

after machining

0.14 nm rms

Powder used: 0.1 μ m size SiO₂ 2 μ m size SiO₂

SR sources vs FEL sources

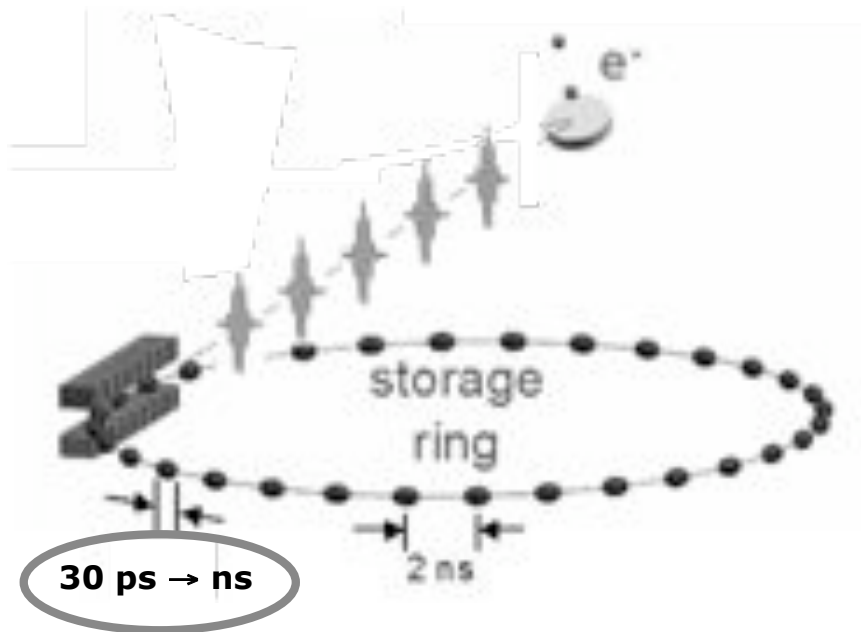

Synchrotron bunch distribution

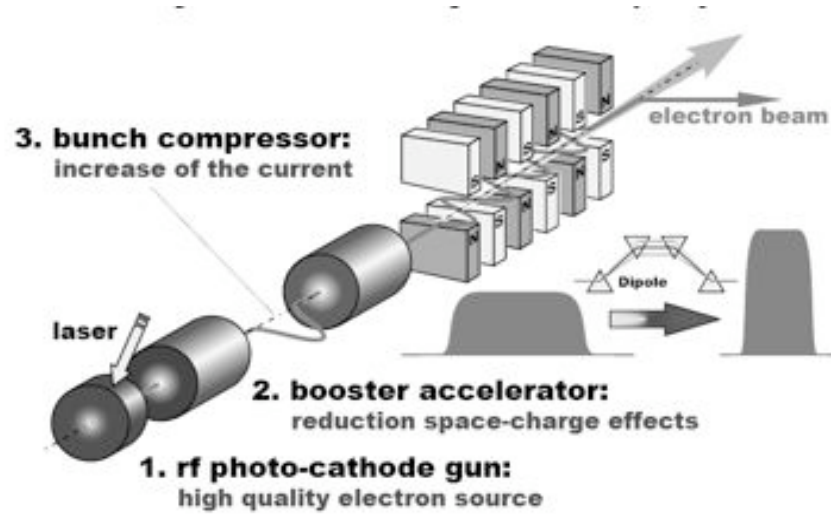

Compress the bunch length and see what's happen

Brilliance

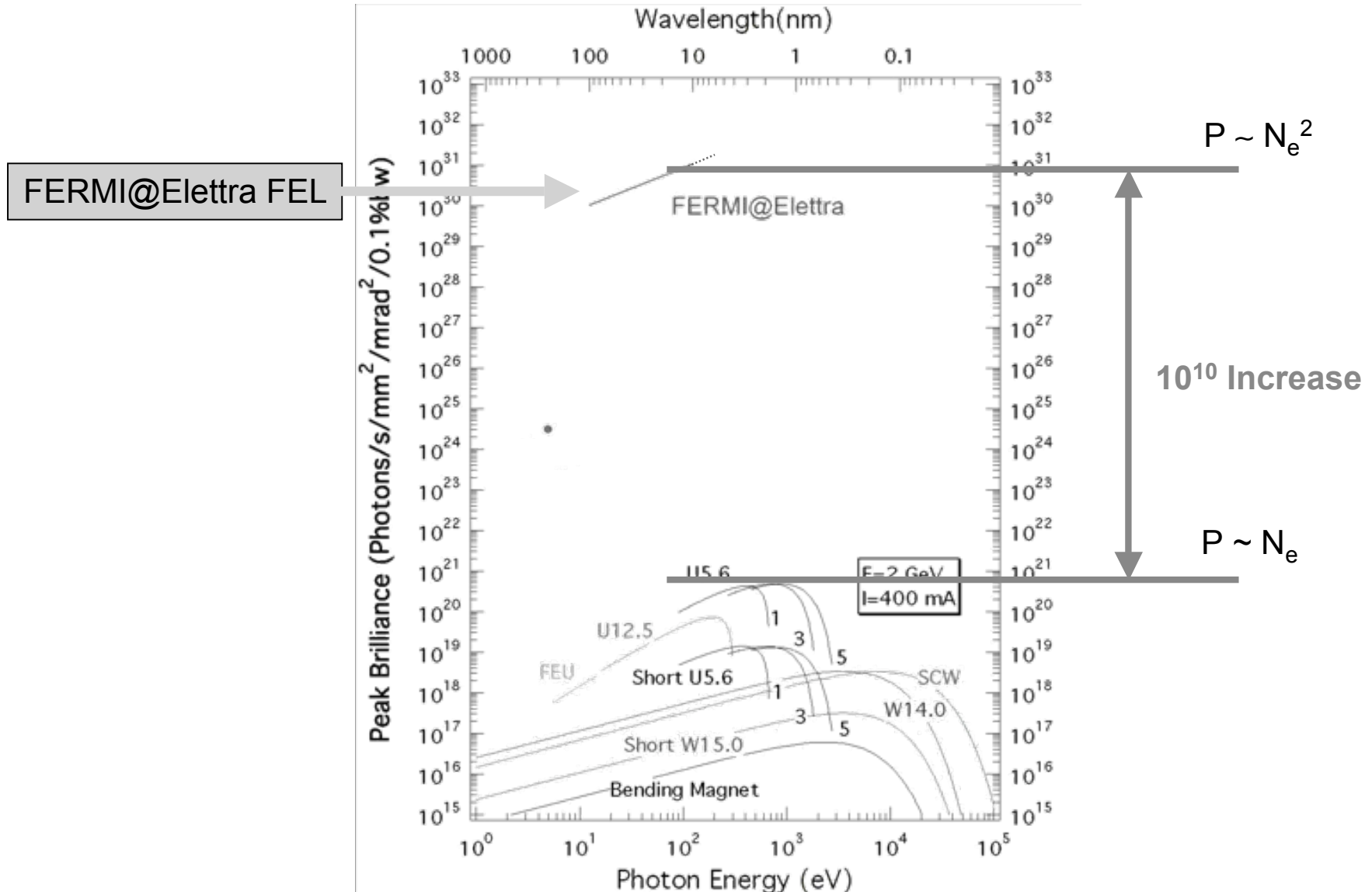

Differences

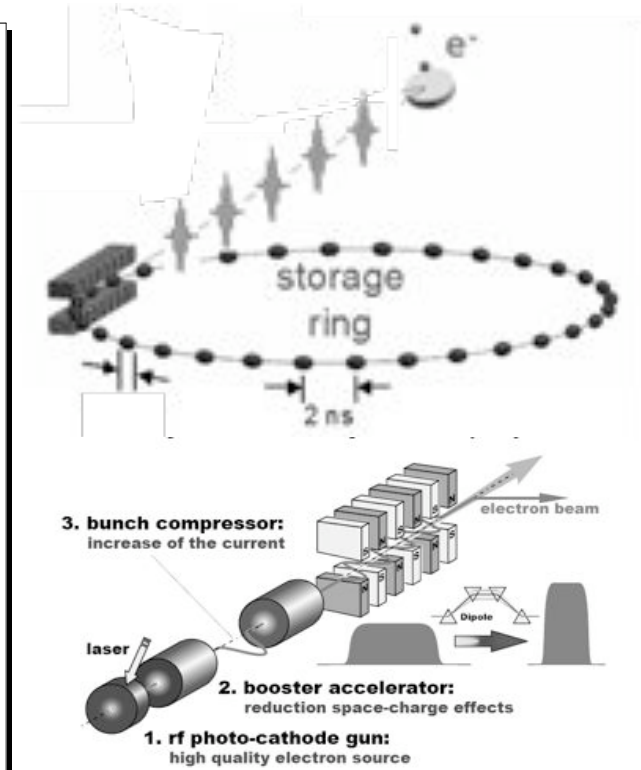
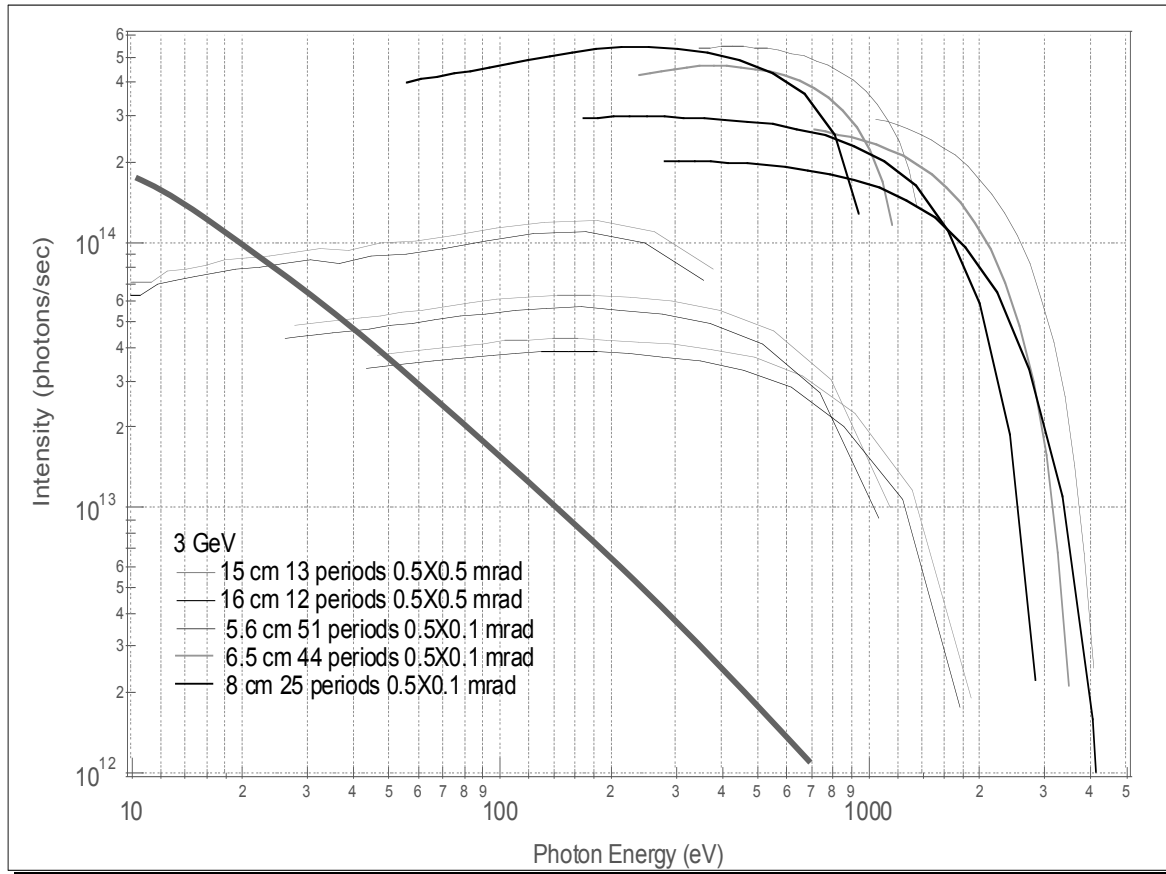

Thermal deformations

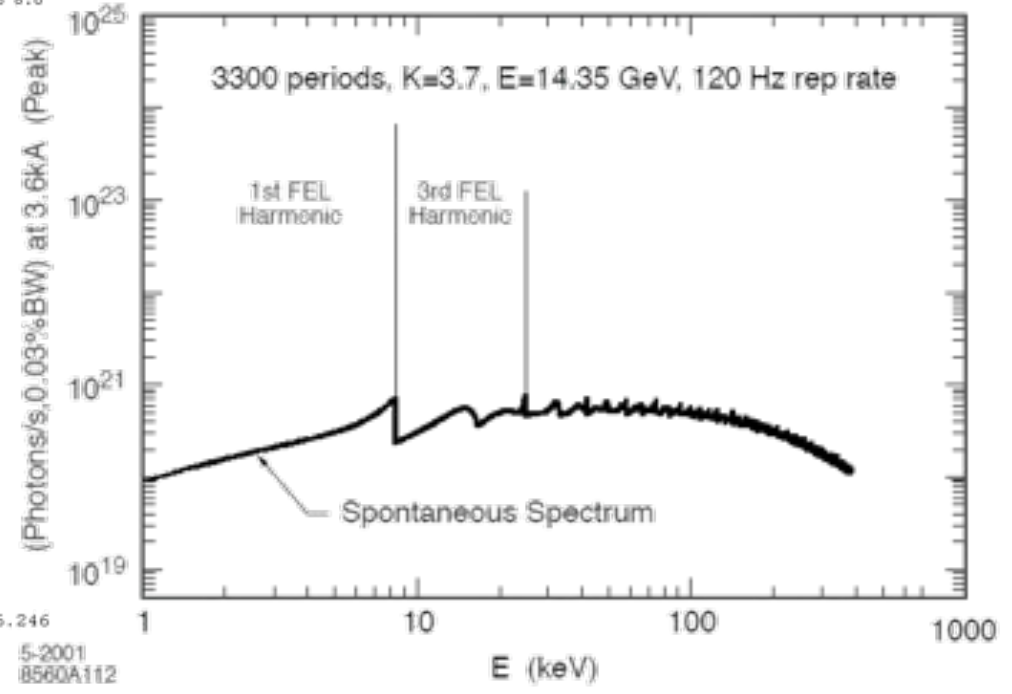
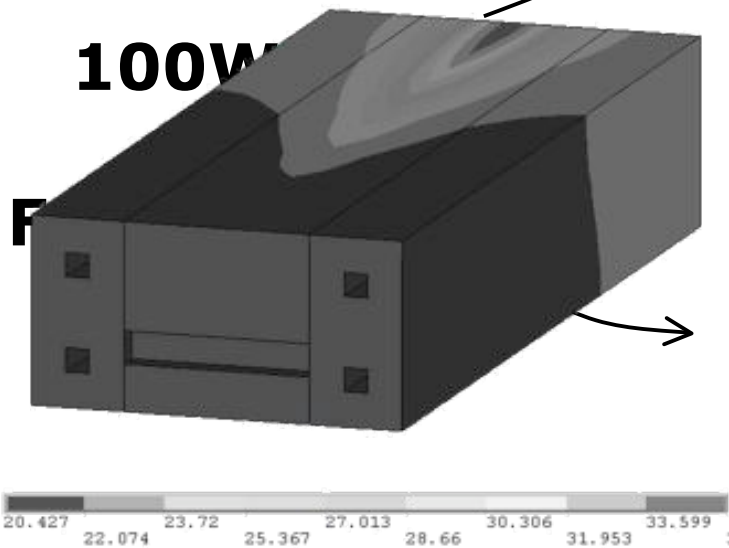
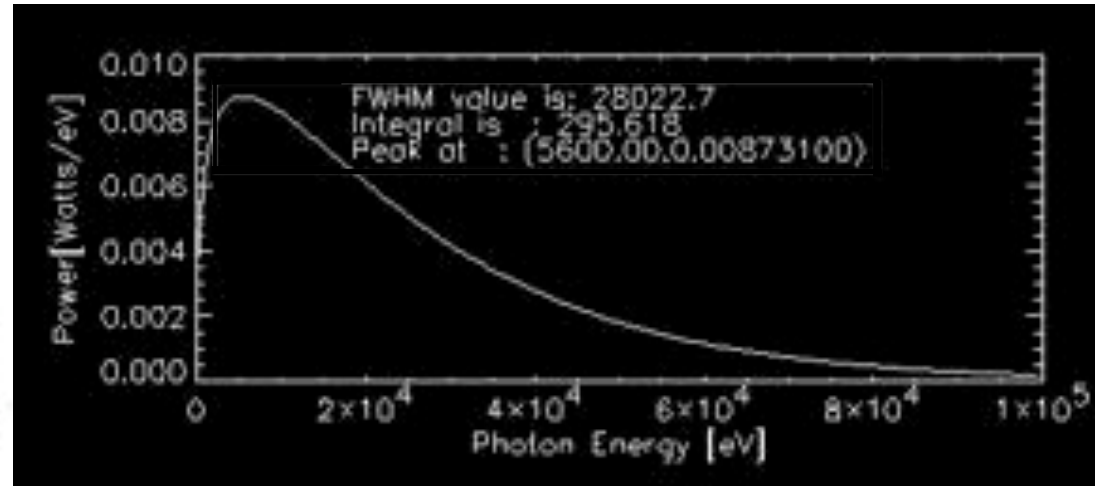
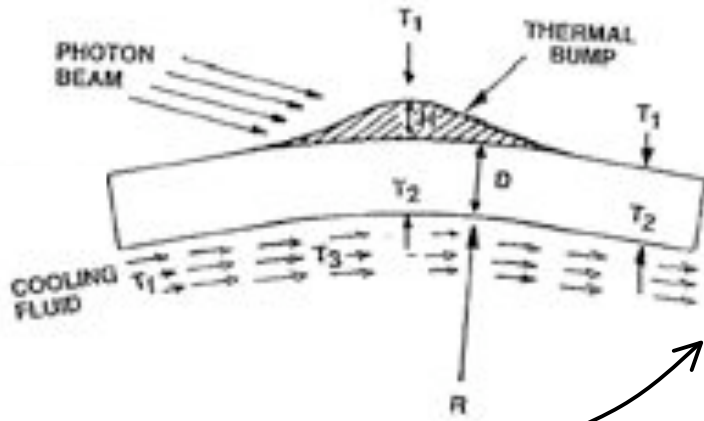

Fluence and damage threshold

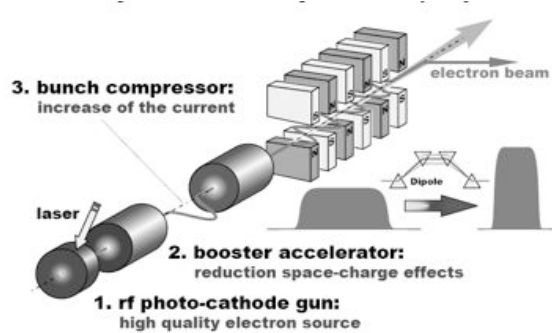

Fluence (Joules/cm²) = laser pulse energy (J) / focal spot area (cm²)
 Intensity (Watts/cm²) = peak power (W) / focal spot area (cm²)
 Peak power (W) = pulse energy (J) / pulse duration (sec)

FEL 1:
 100 fsec; 5 GW → ~ 0.5 mJ
FEL 2:
 200 fsec; 1 GW → ~ 0.2 mJ

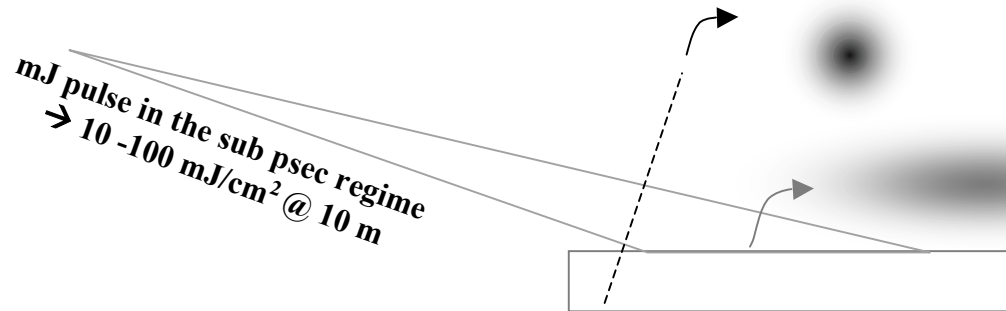

Matrial	Damage threshold @ 90 nm	Safety angle 100 nm (10 /20/40 m)	Estimated damage threshold @ 40 nm	Safety angle 40 nm (10 /20/40 m)
Cu/Glidcop bilk	~ 500 mJ/cm ²	24° / 90°/ 90°	~ 1000 mJ/cm ²	41° / 90°/ 90°
Au coating	40 mJ/cm ²	1.9° / 7.6°/ 32°	50 mJ/cm ²	4.8° / 20°/ 77°
Silicon bulk	30 mJ/cm ²	1.5° / 6°/ 23°		
Graphite coating	60 mJ/cm ²	2.9° / 11.5°/ 53°	240 mJ/cm ²	9° / 40°/ 90°
YAG bulk	70 mJ/cm ²	3.3° / 13.4°/ 68°		

Fluence and damage threshold

High density carbon (or B4C) are very “strong” materials but...

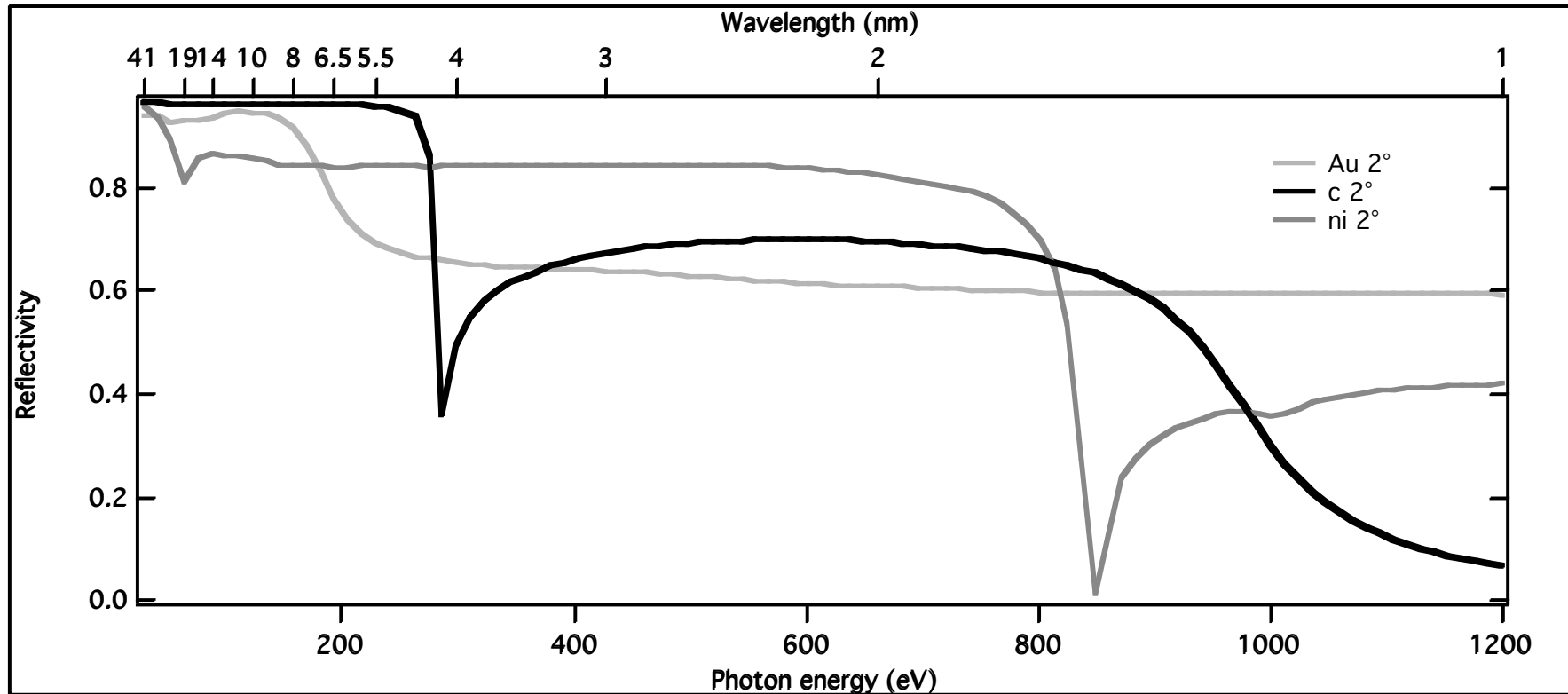

Proper mirror coatings (and multilayers) must be made.

Binding layers are very very important

Gold or platinum are “soft” or “tender” materials.....

Harmonic rejection and monochromatisation

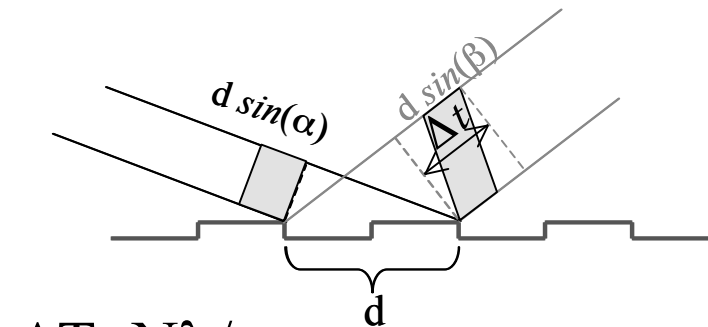
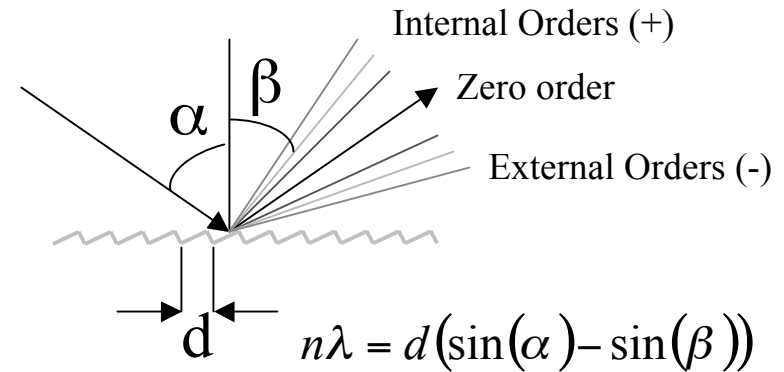
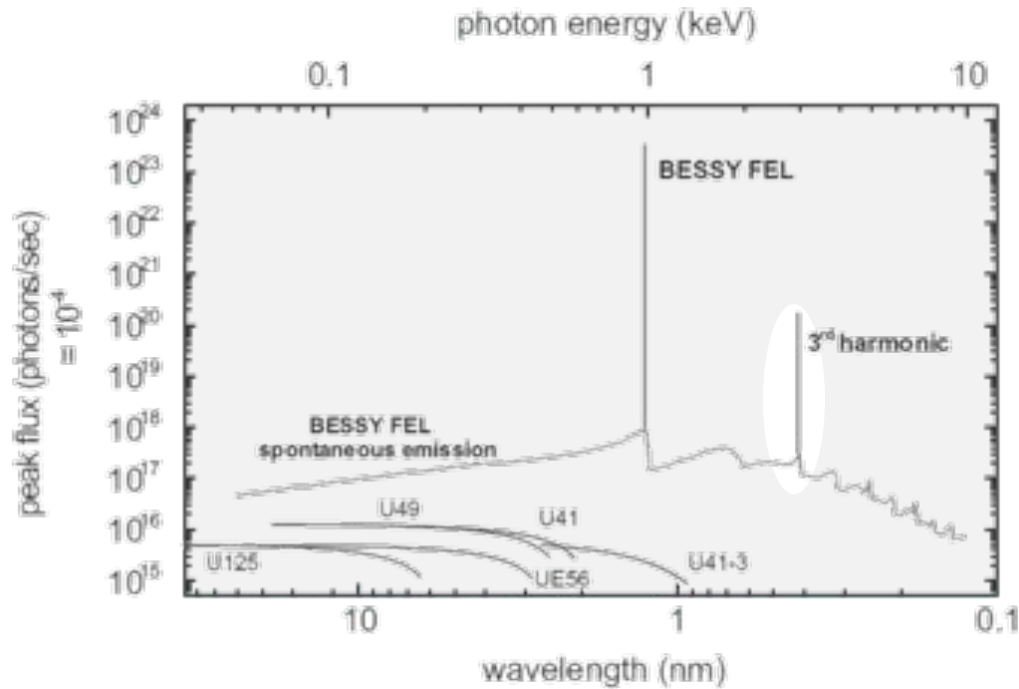

$$\Delta T = N\lambda/c$$

Examples:

100 nm cff 0.98 α 80.41	11.1 l/mm $\Delta t=74$ fsec FWHM
40 nm cff 0.93 α 81.8	33.3 l/mm $\Delta t=65$ fsec FWHM
30 nm cff 1.25 α 82.65	150 l/mm $\Delta t=300$ fsec FWHM
10 nm cff 1.73 α 85.5	600 l/mm $\Delta t=236$ fsec FWHM

Grating's groove

Laminar

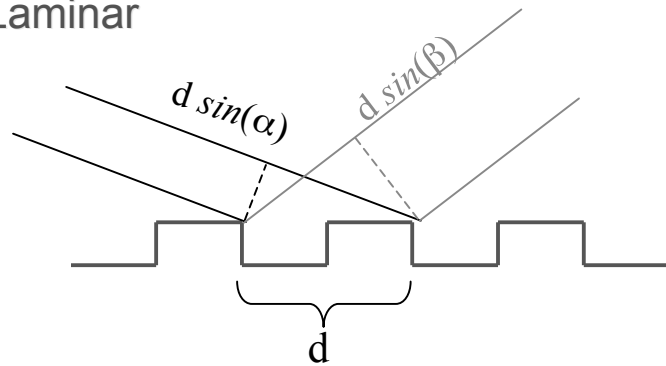

Blaze

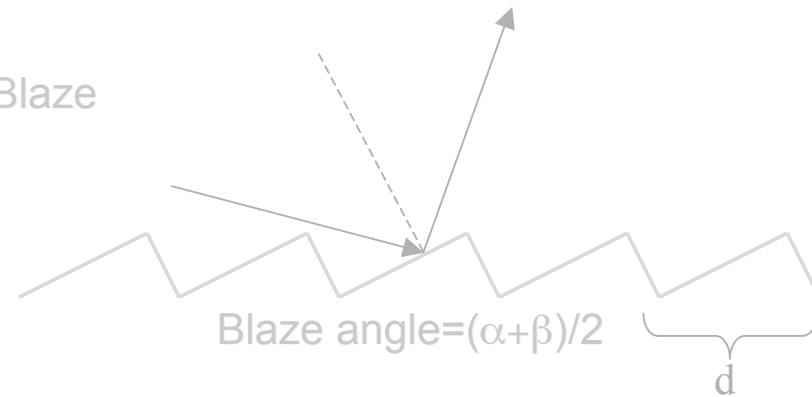

A lot of energy deposited on the grating facet

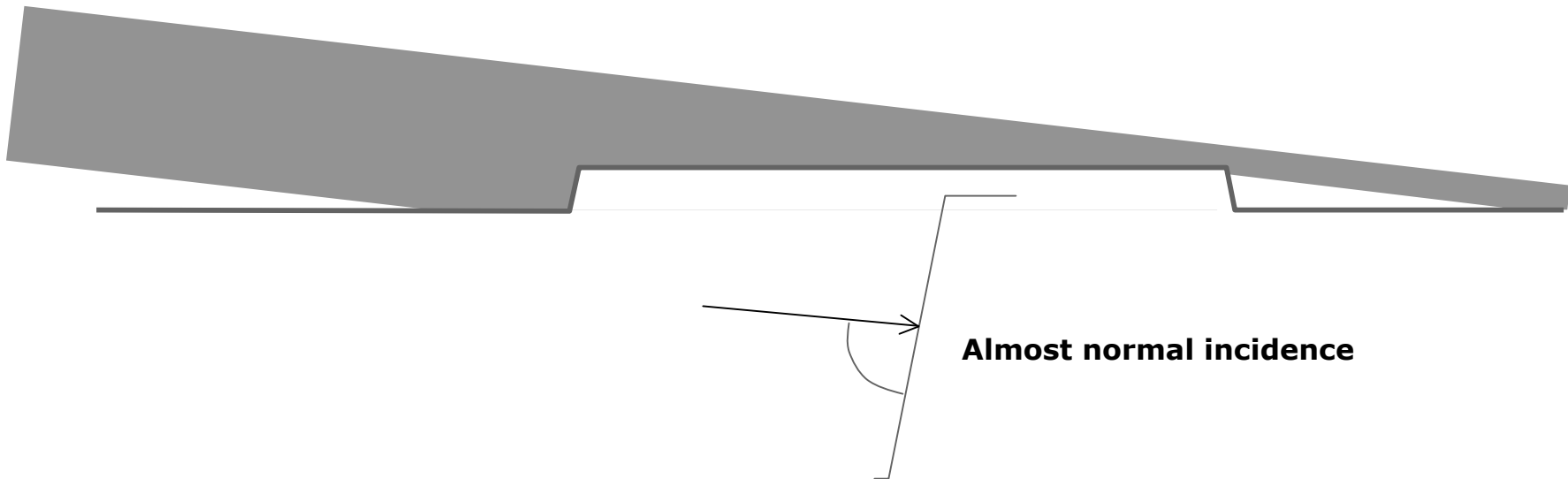

Grating grooves

Laminar

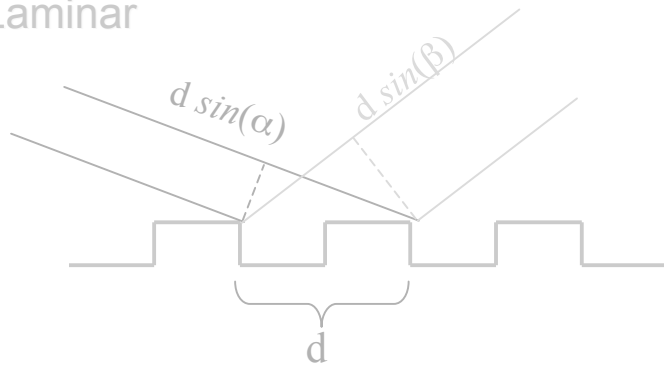

A lot of energy deposited on the grating facet

Blaze

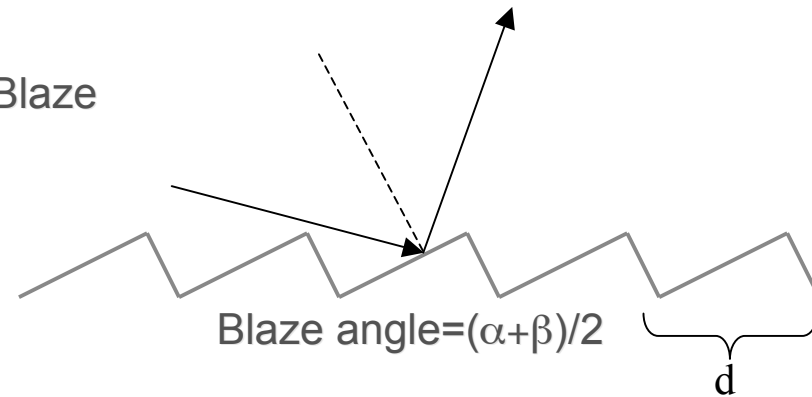

Energy distributed on the grating facet

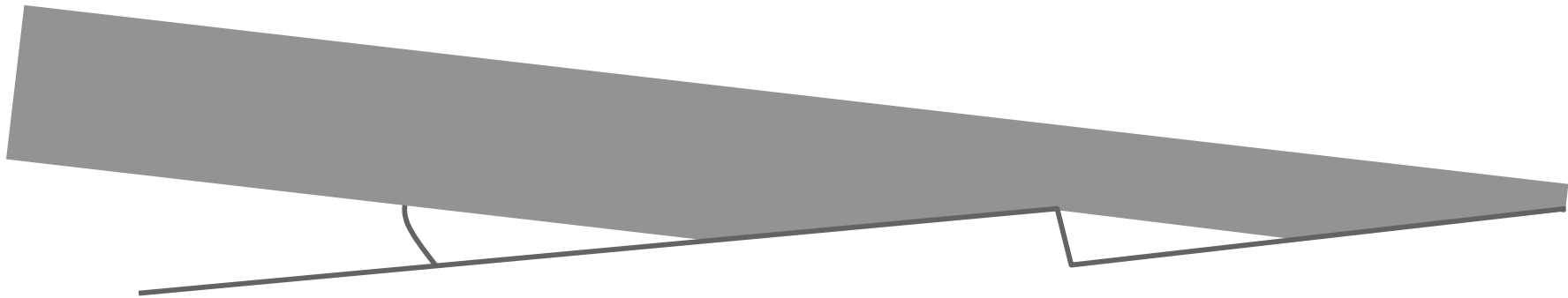

Multilayers

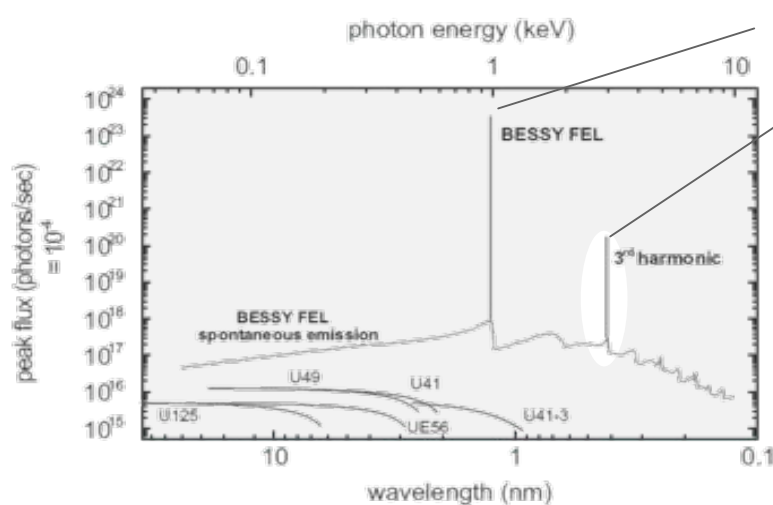

$$\frac{\text{Intensity } 20\text{nm (1st harm)}}{\text{Intensity } 6.33\text{nm (3rd harm)}} \geq 100$$

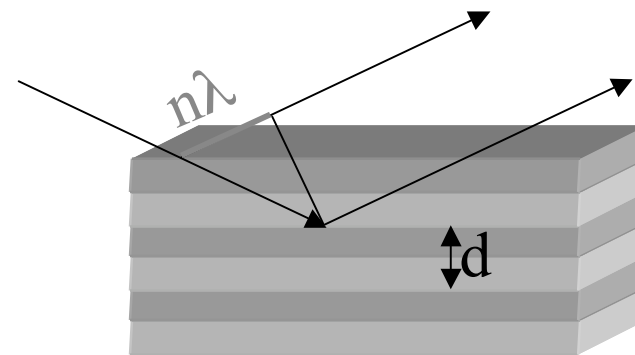

Ratio eff. Multilayer	Total
6.33nm/eff. 20nm	6.33nm/eff. 20nm
1 mirror → 57	1 mirror → 0.6
2 mirrors → 3300	2 mirrors → 33
4 mirrors → 10 ⁷	4 mirrors → 10 ⁵

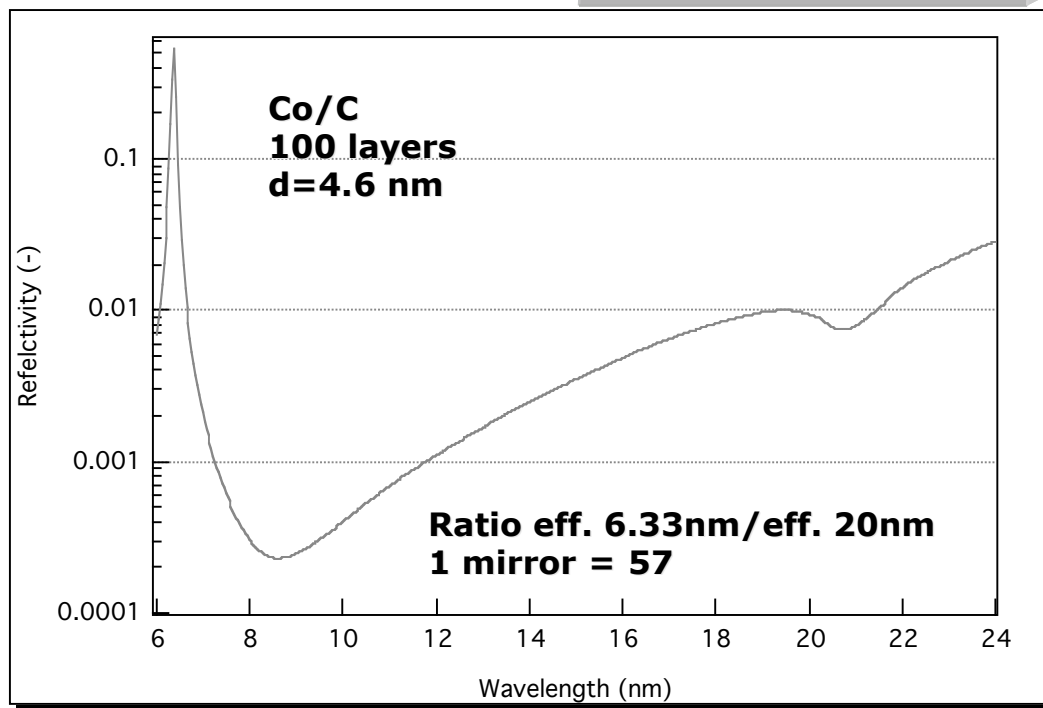
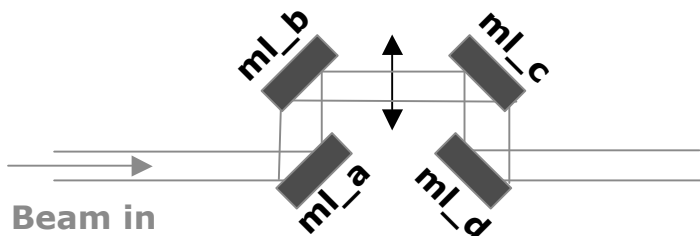

Multilayers

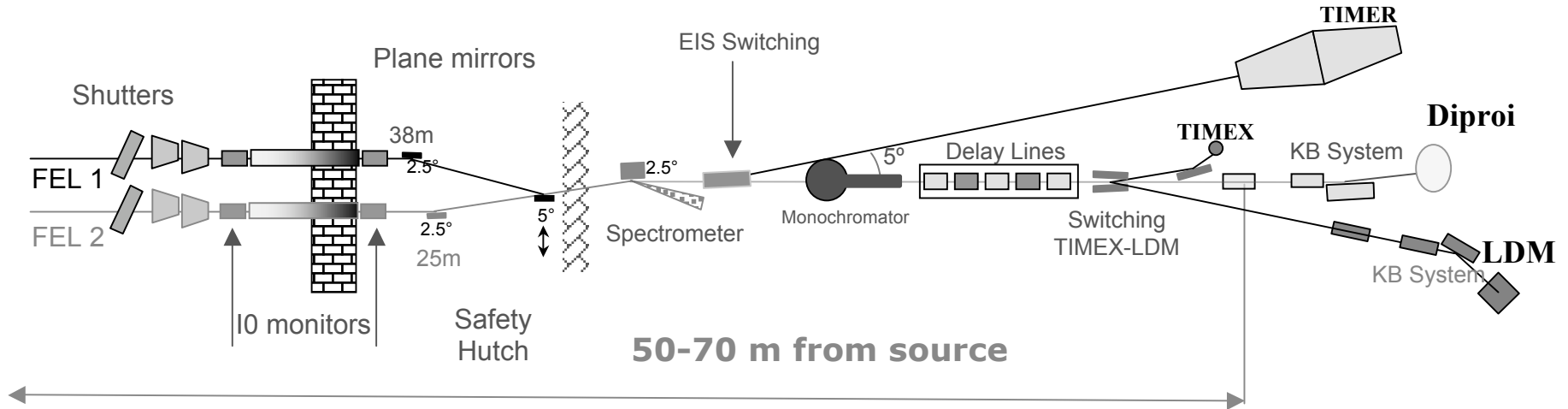

0.9-1.8 mJ/cm² on the 45° mirror surface at 20 nm
0.9-1.8 mJ/cm² adsorbed

Multilayers suffer from fast aging effect

	Material	Efficiency
40 nm	Sc/Si	70%
20 nm	Mo/Si	70%
13.3 nm	Mo/Si	75%
6.33 nm	Co/C	50%

<i>Material</i>	<i>Damage threshold @ 32 nm</i>	<i>Safety margin @ 50 m, 45° Full beam Absorbed</i>
Silicon bulk	87 mJ/cm ²	48 - 48
α-C	60 mJ/cm ²	33 - 33
SiC	140 mJ/cm ²	77 - 77
B4C	200 mJ/cm ²	111 - 111

Multilayers

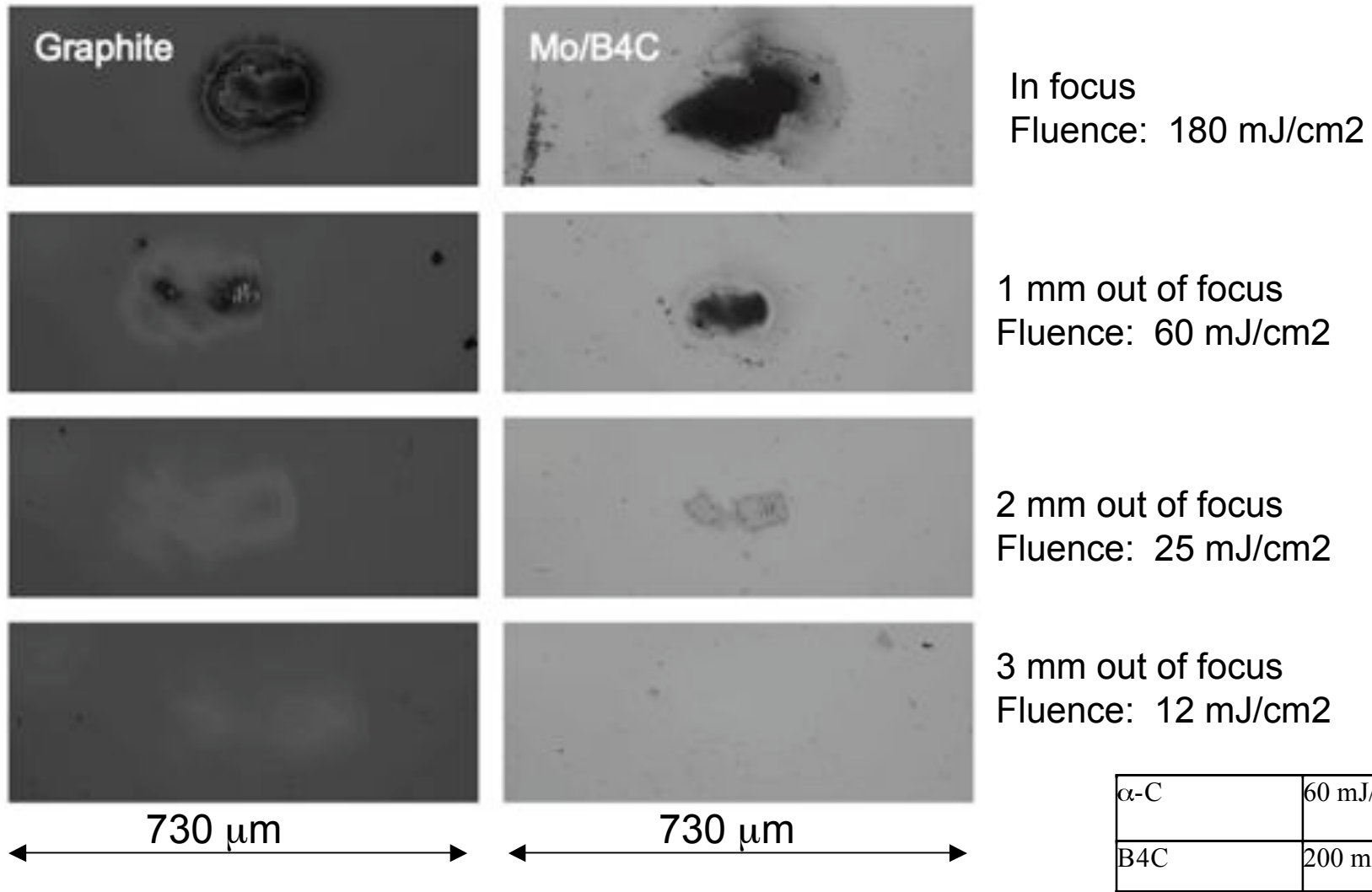

Measured at 400 nm at the EIS laser lab

Pump and probe - delay line

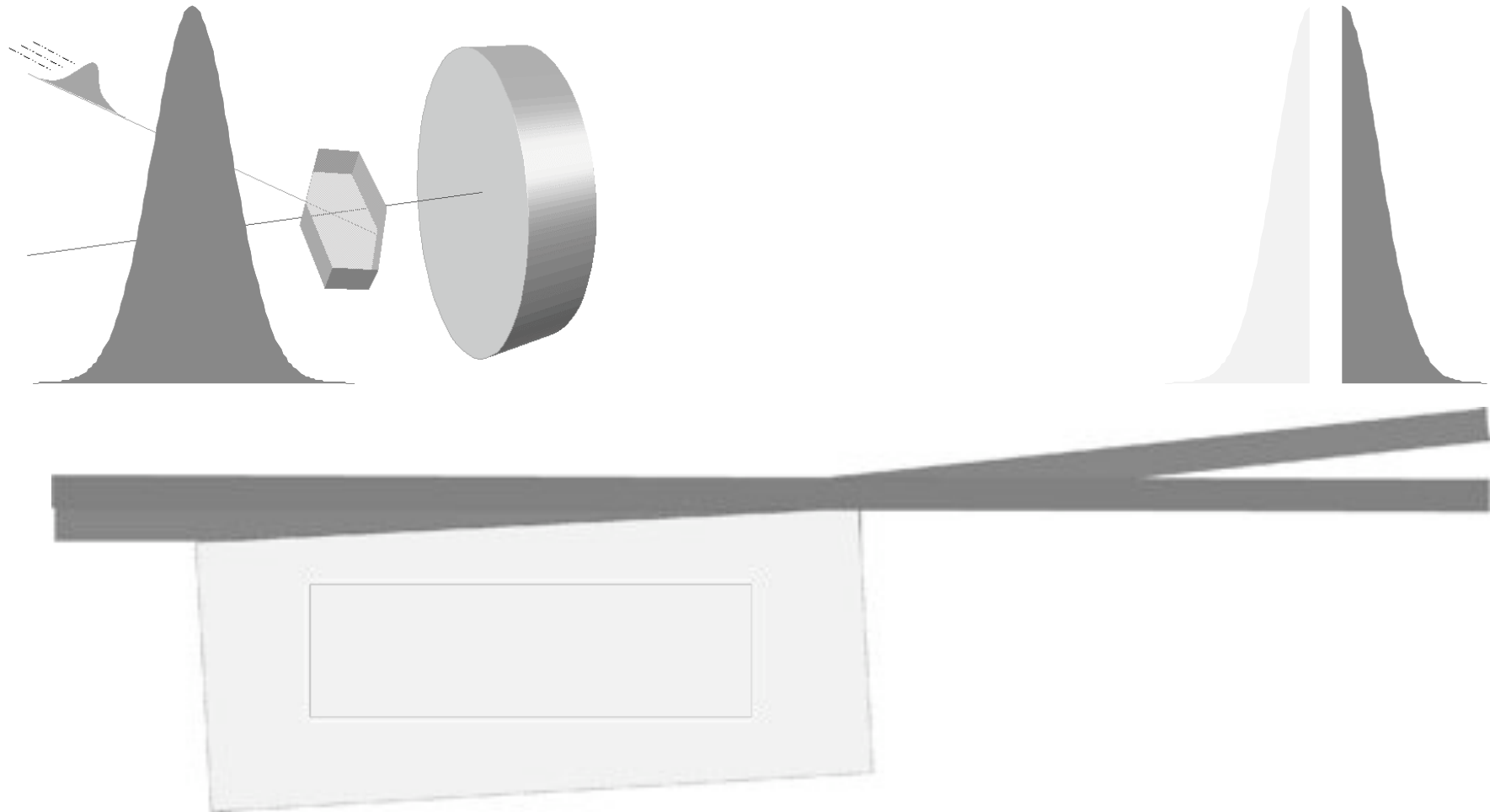

Delay from -2.5ps to +35 ps
Pump with 1st Probe with 1st or 3rd (multilayer positioned in the fixed "probe" line)

Pump and probe - delay line

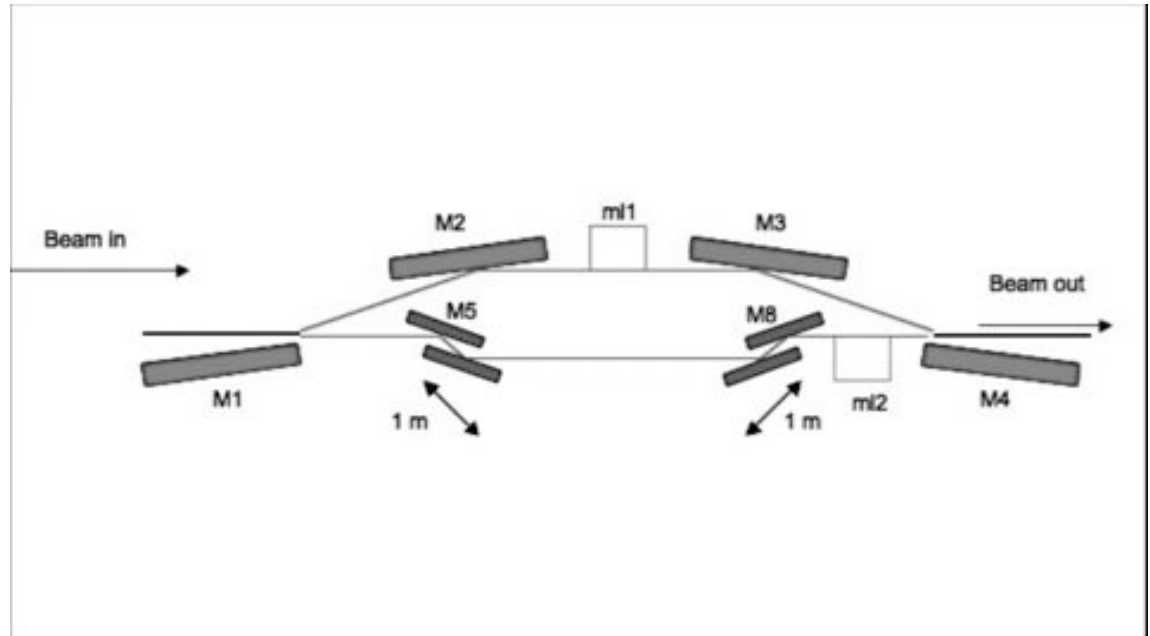
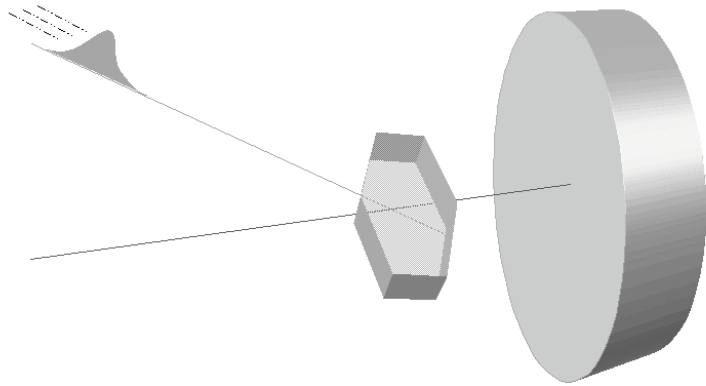

Delay from -2.5ps to +35 ps
Pump with 1st Harmonic
Probe with 1st or 3rd (multilayer positioned in the fixed "probe" line)

Required movement range and step: $\approx 1\text{m}$. few μm

Precision required

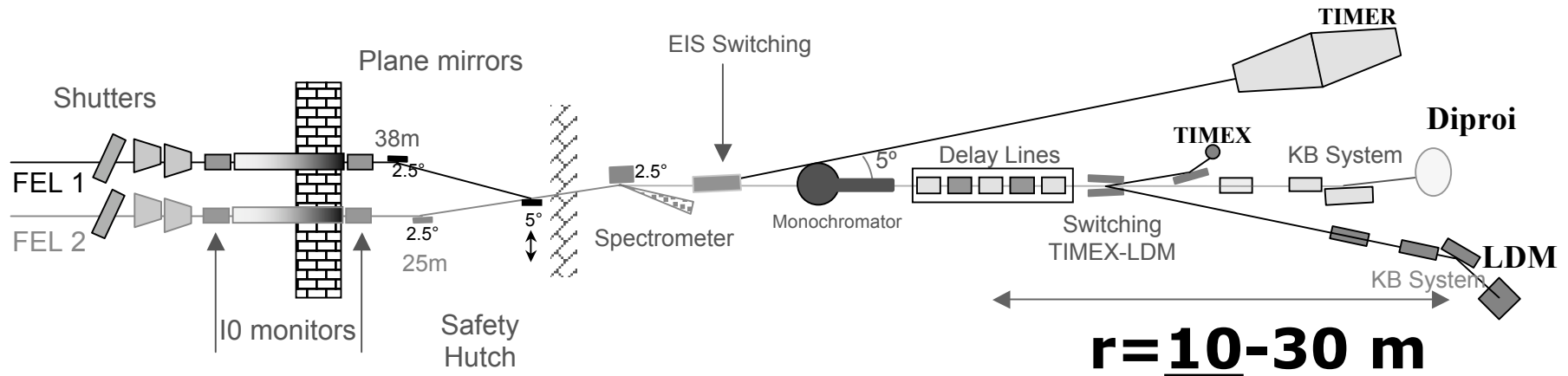

Spot dimension $< 10 \mu\text{m}$ (could easily be less)

Beam offset = $2\delta\theta(\text{angular error on mirror}) * r \rightarrow 10 \mu\text{m}$

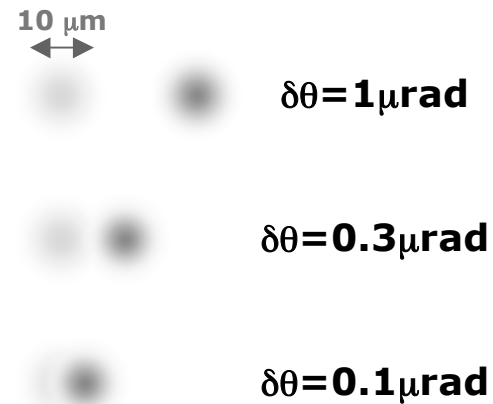
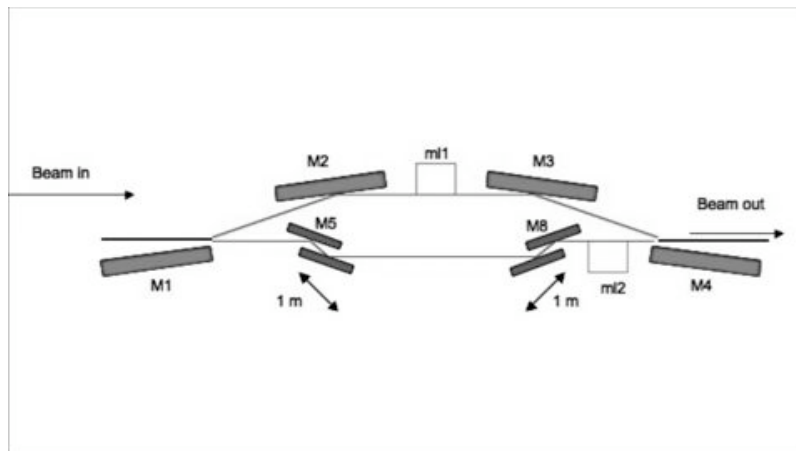

Precision required

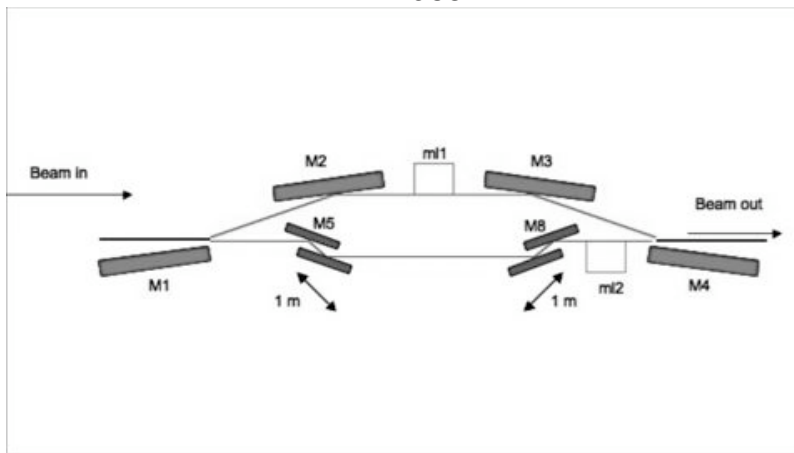
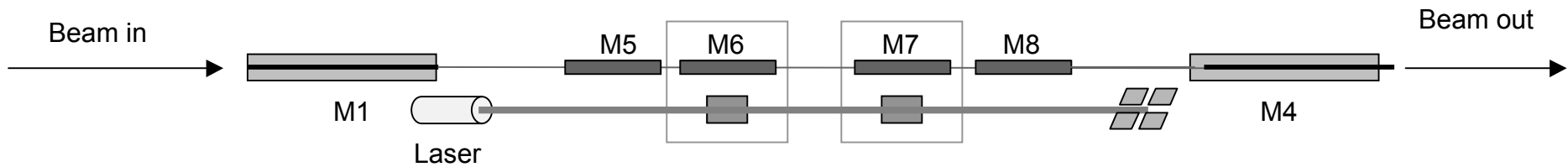
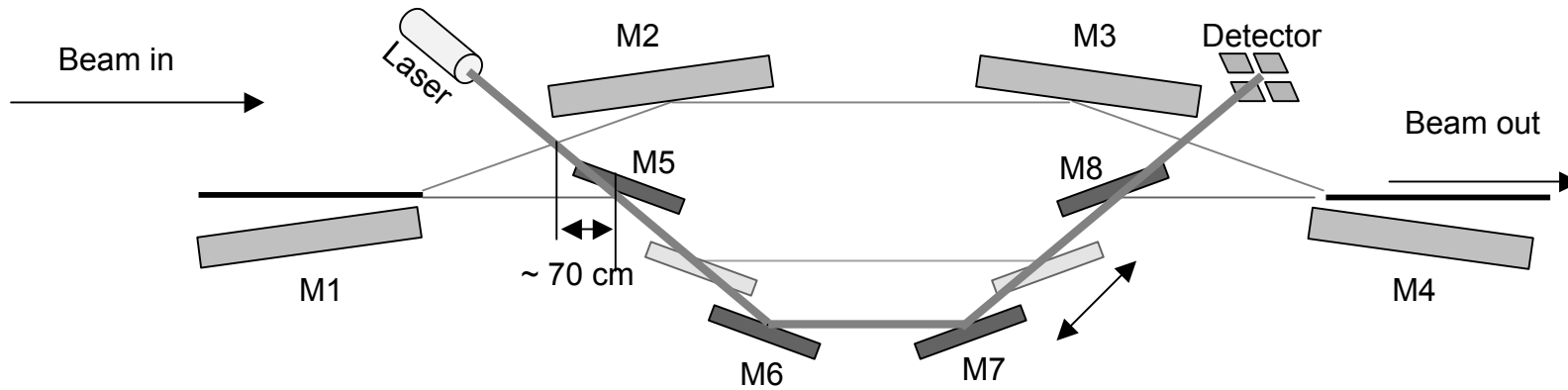

$$\delta\theta = 0.3 \mu\text{rad}$$

$$\delta\theta = 0.1 \mu\text{rad}$$

Delay line - Coherent beam diffraction effect

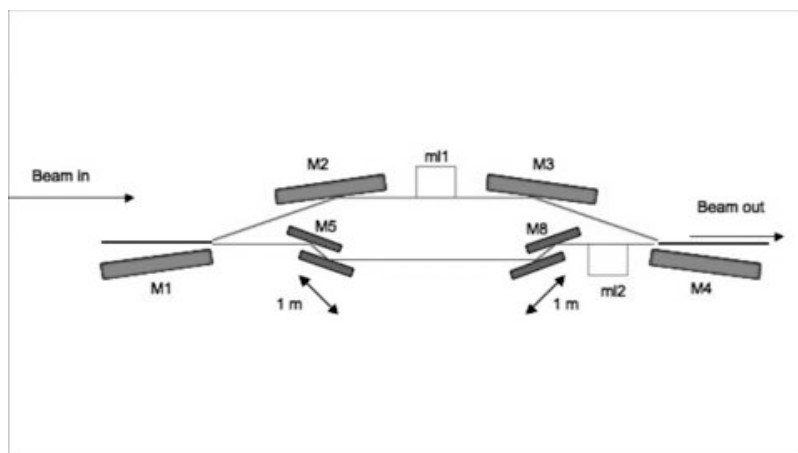
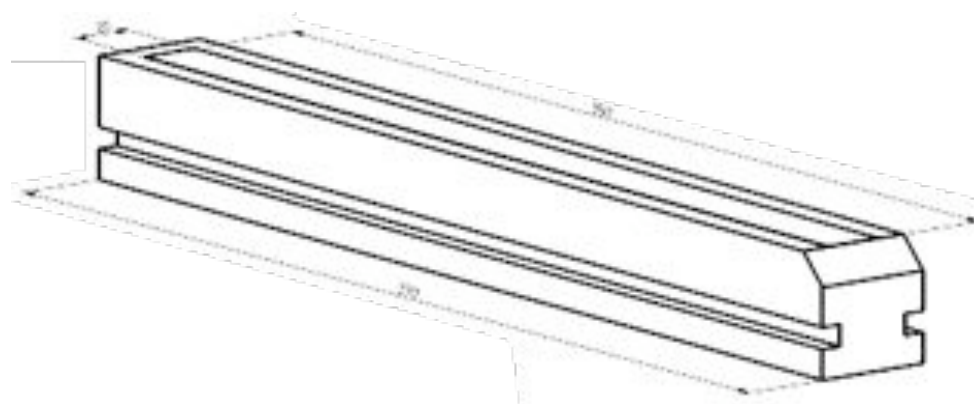
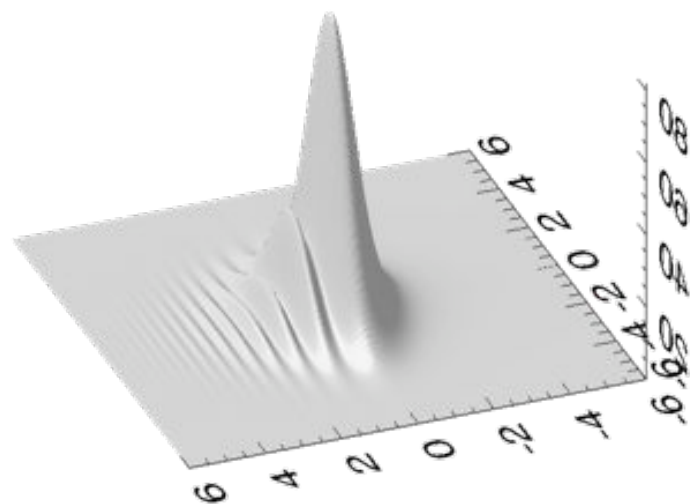

horiz pol, horiz cut through peak

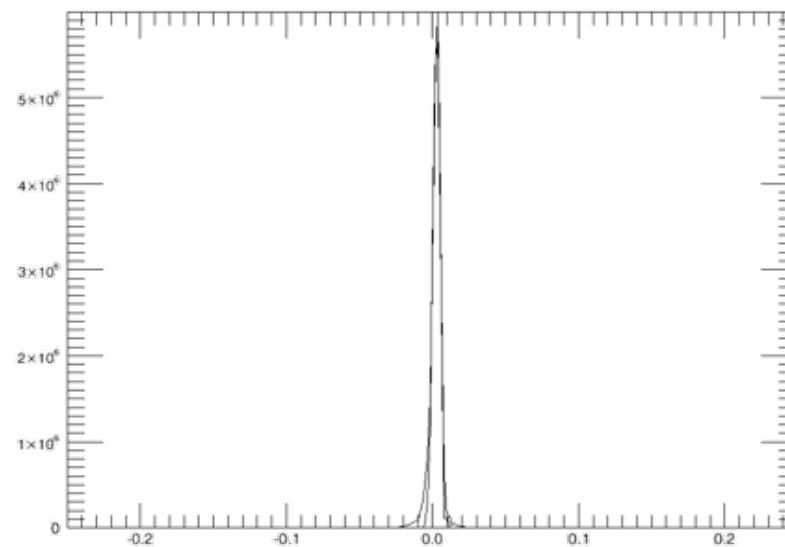

Metrology

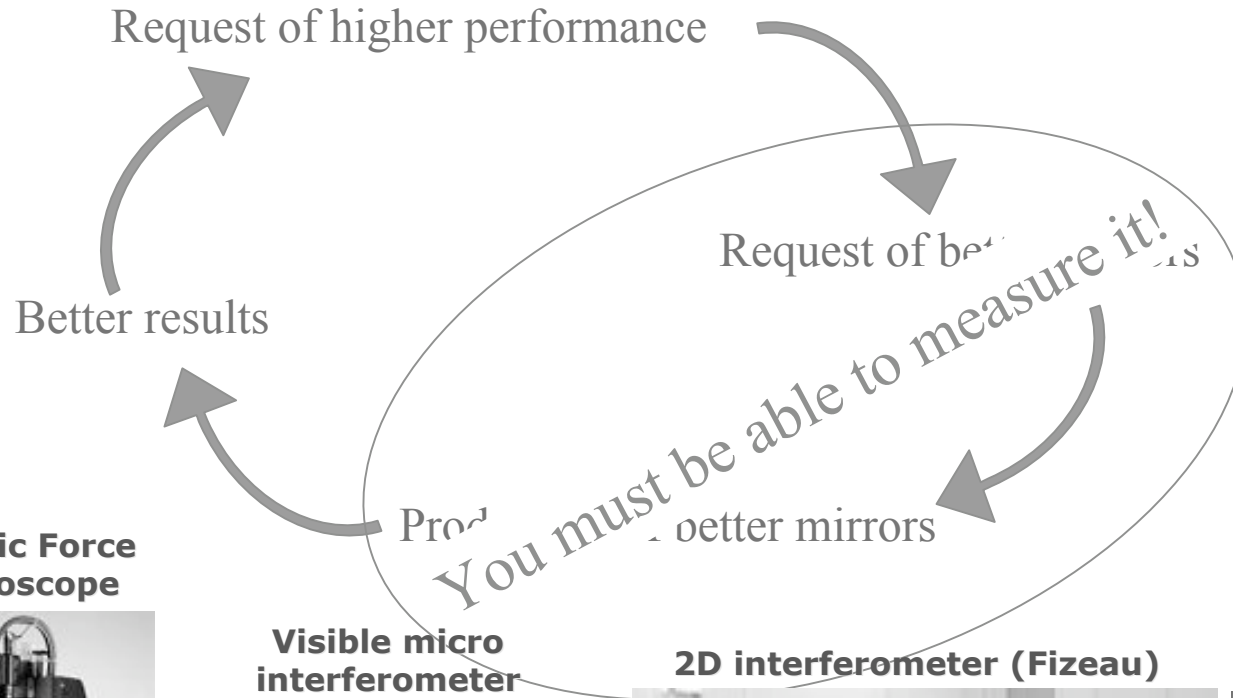

**Atomic Force
Microscope**



**Visible micro
interferometer**



2D interferometer (Fizeau)



Long Trace Profiler (LTP II)



Long trace profiler

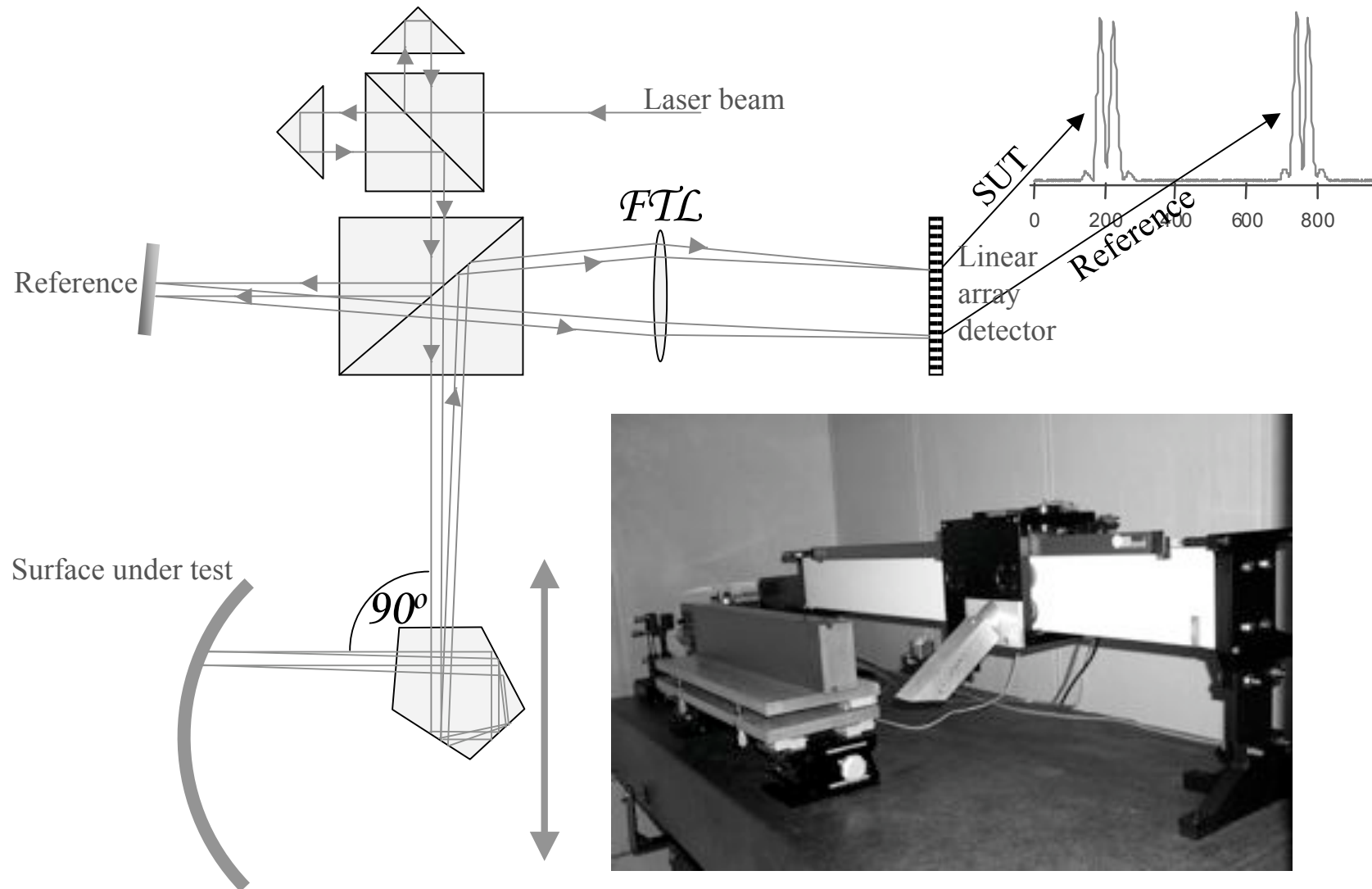

Fizeau Interferometer

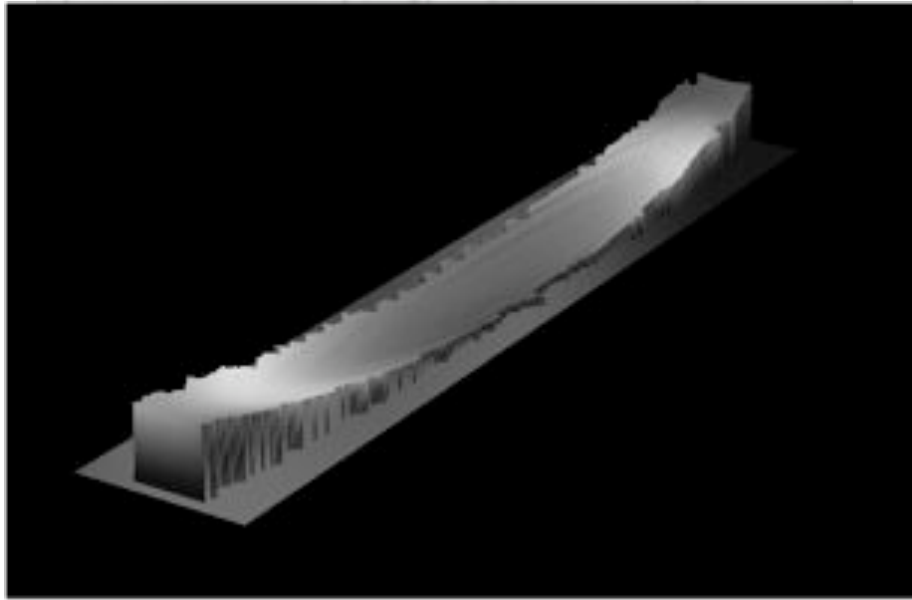

3D measurement of optical surfaces

$\lambda/100$ precision

$\lambda/2000$ repeatability

λ usually 632.8 nm or 1100 nm

Accessories

Transmission spheres

Converger for sagittal radii and NI mirrors

Diverger for NI mirrors with $R > 2$ m

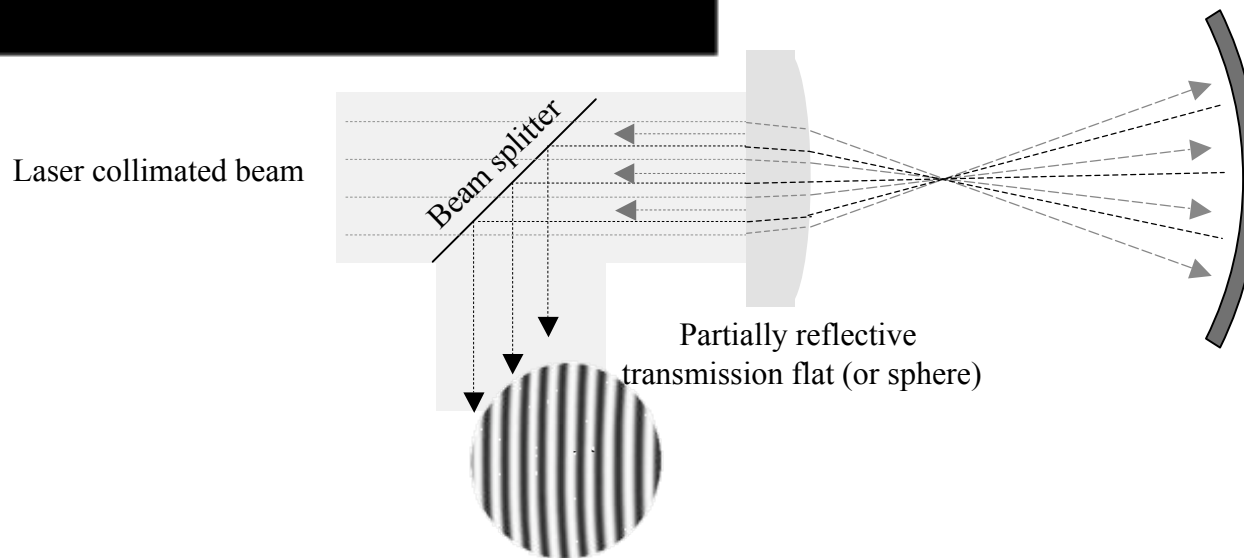

Roughness measurement

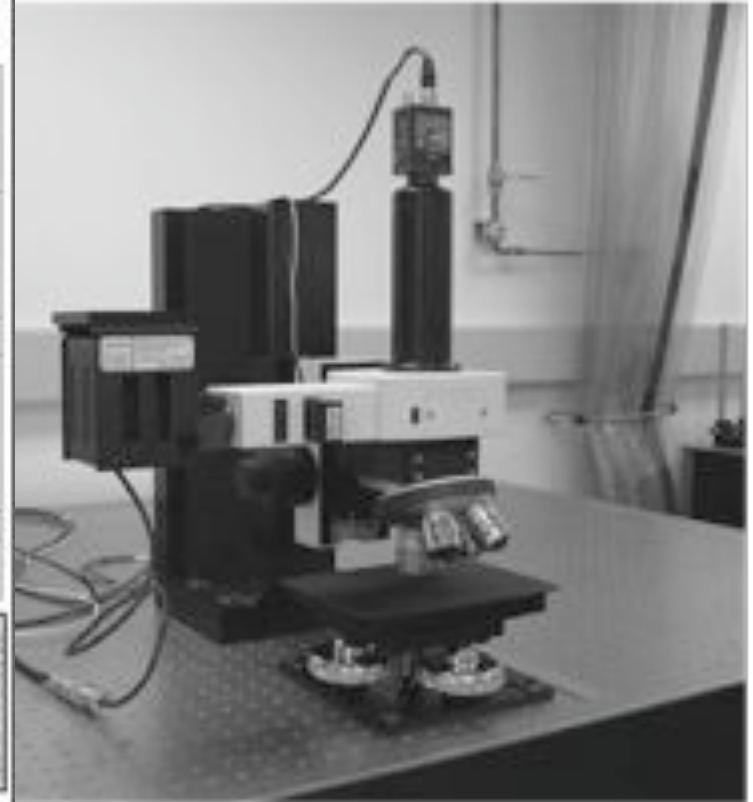
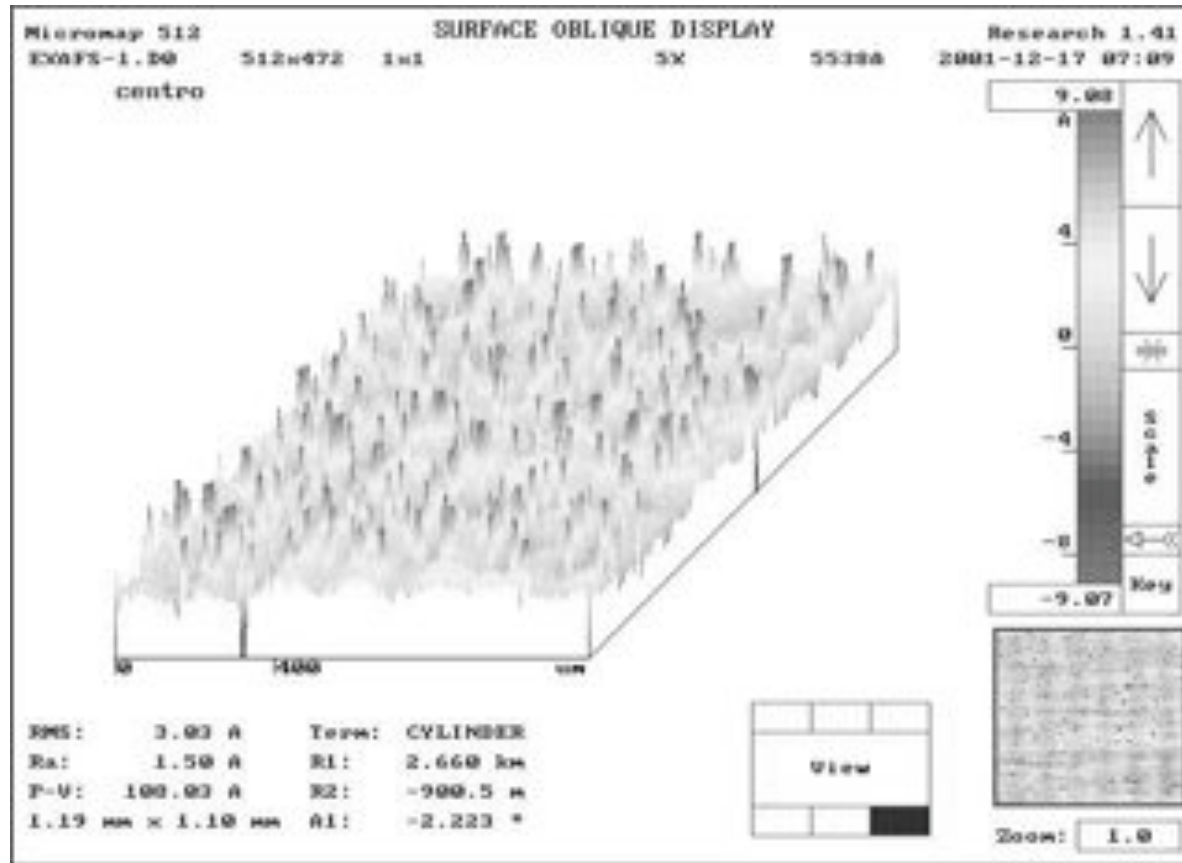

Michelson Interferometer



Atomic force microscope

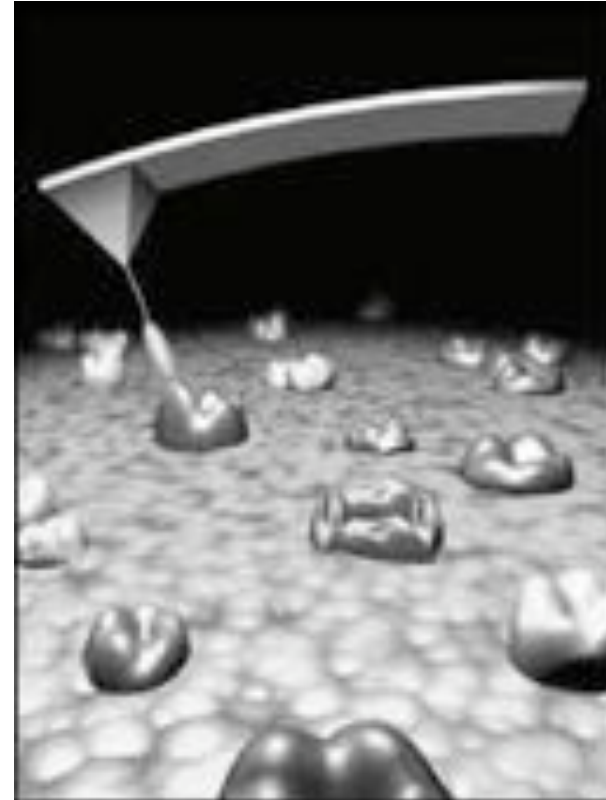
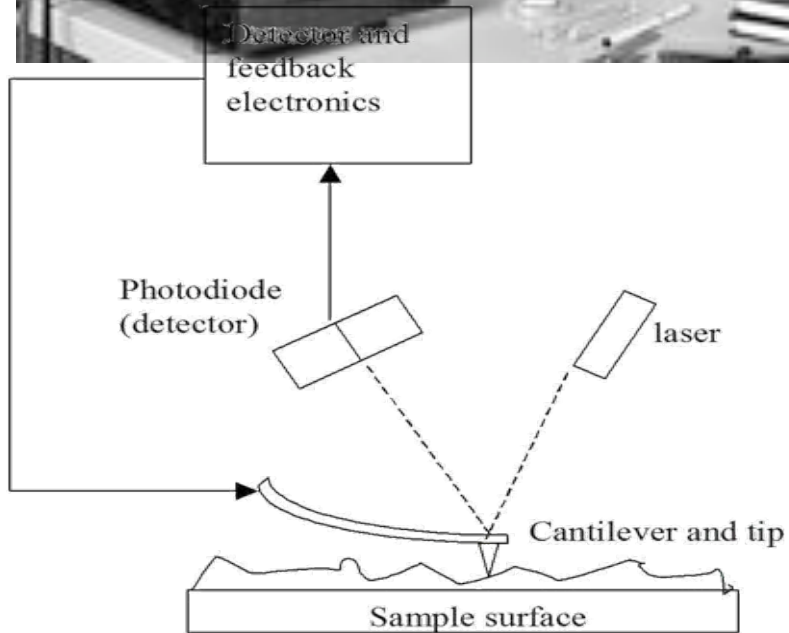

Power spectral density

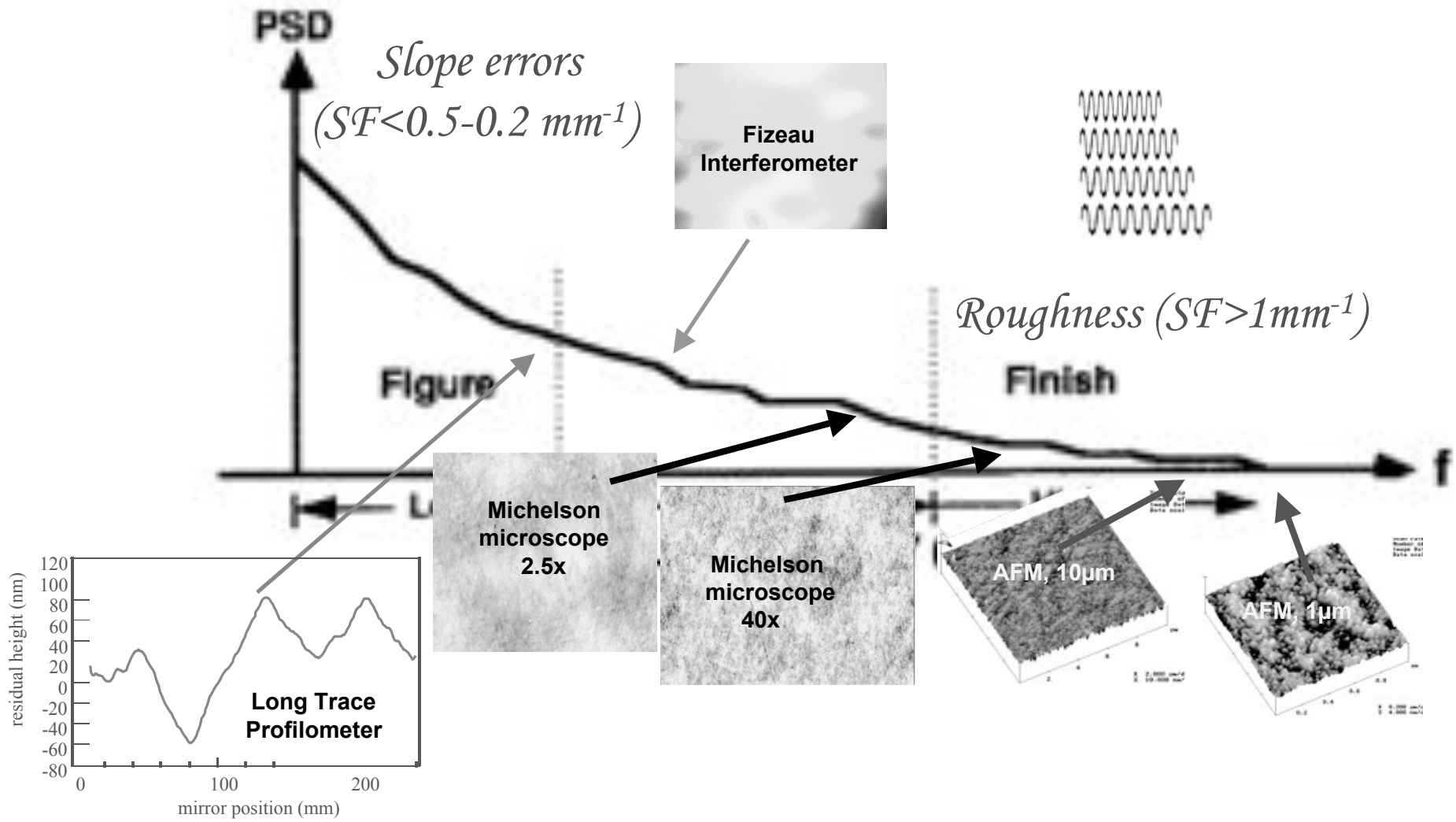

Bibliography

Books:

W. B. Peatman: **Gratings Mirrors and Slit** Gordon Sci. Publ. Amsterdam (1997) (Soft X-ray optics, introduction to SR sources)

D. Attwood, **Soft X-Rays and Extreme Ultraviolet Radiation**, Cambridge University Press (Interaction radiation-matter, SR sources, UV and Soft X-Ray optics)

A.A. **Modern Developments in X-ray and Neutron Optics** (Recent achievement in multilayer, metrology, ray tracing and X-ray lenses)

CXRO X-ray data booklet Lawrence Berkeley Nat. lab. (2001) free (general information and table useful when using X-ray)

Programs: Shadow (ray tracing) <http://www.nanotech.wisc.edu/shadow/shadow.html>

XOP (general optical calculation) <http://www.esrf.fr/computing/scientific/xop>

SPECTRA (synchrotron source) http://radiant.harima.riken.go.jp/spectra/index_e.html

Links: Centre for X-ray Optics <http://www-cxro.lbl.gov/> (*general information and on line software*)

The international society for Optical Engineering <http://www.spie.org>

Optics.org <http://optics.org>

Photonics.com <http://www.photonics.com/>