

MicroBulk and results in high pressure noble gases

I. Giomataris, CEA-Irfu

New fabrication technology

Micro-Bulk

Type1

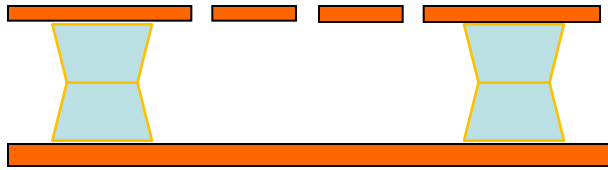

An I. Giomataris and R. De Oliveira patented idea

Type2

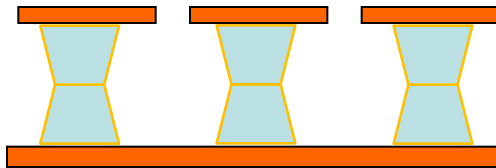

50 μm and 25 μm gaps fabricated

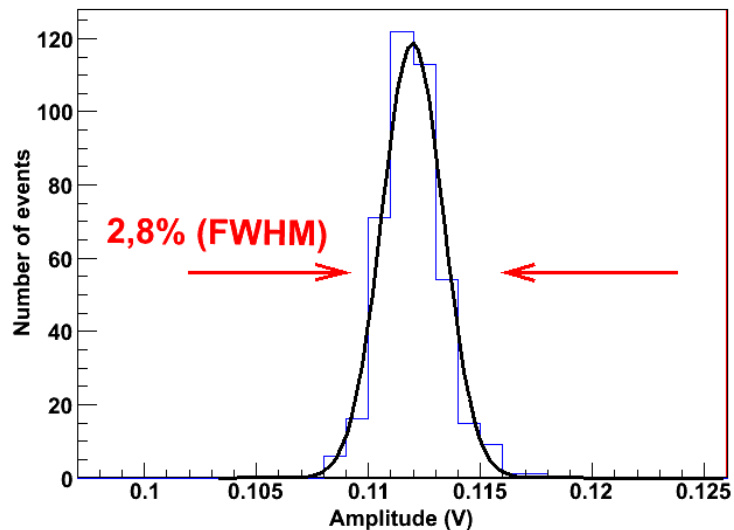

Xe @ 2 bar
Neutrinoless Double Beta (0nbb)
using ^{136}Xe target

Very good energy resolution

- 11% at 5.9 keV
- 5.5% at 22 keV
- <1.5% with Am alpha source

Other advantages

- Flexible structure (cylinder)
- Good uniformity
- Low material
- Low radioactivity
- Long term stability ?

I. Giomataris

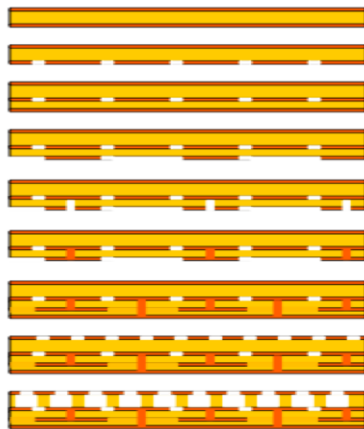
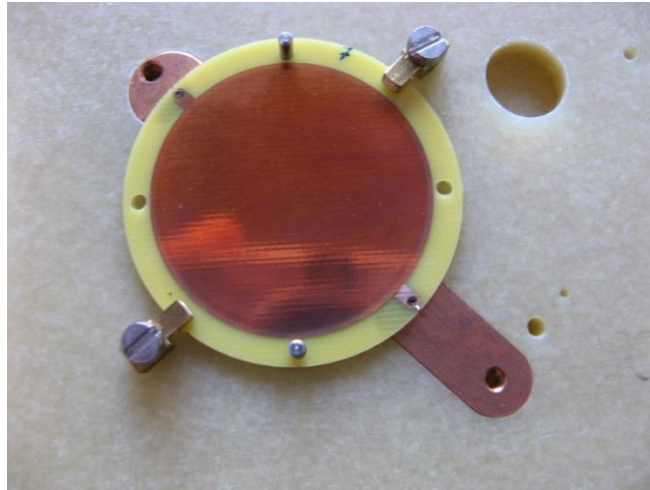

- Double side Cu-coated ($5\ \mu\text{m}$) Kapton foil ($50\ \mu\text{m}$),
- Construction of readout strips/pads (photolithography)
- Attachment of a single-side Cu-coated kapton foil ($25/5\ \mu\text{m}$)
- Construction of readout lines
- Etching of kapton
- Vias construction
- 2nd Layer of Cu-coated kapton
- Photochemical production of mesh holes
- Kapton etching / Cleaning

Systematic study with additional etching

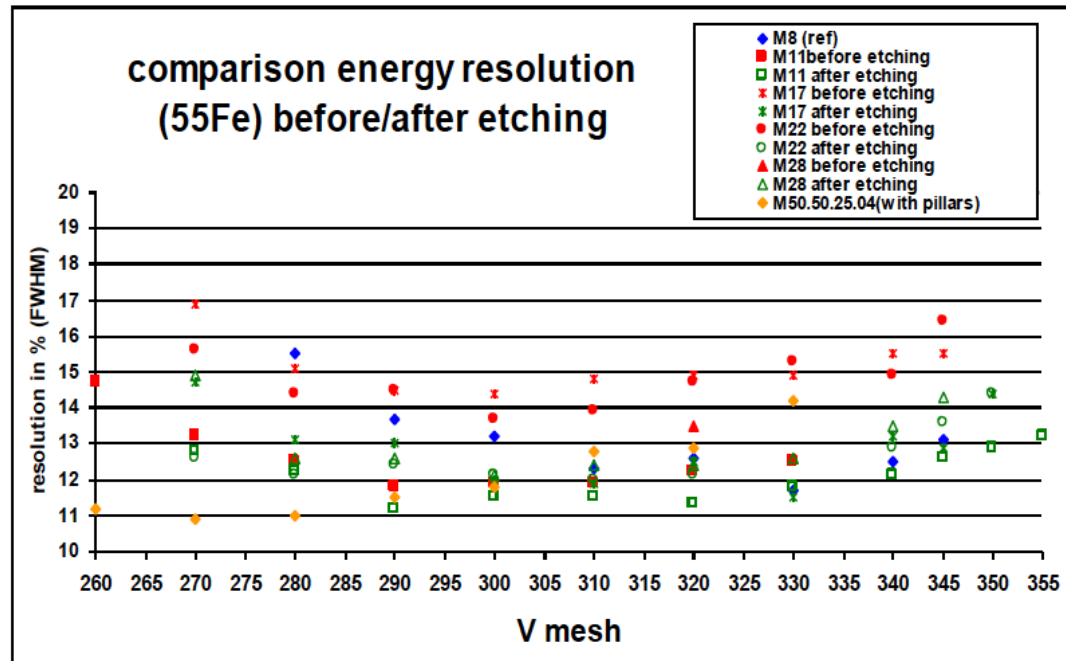
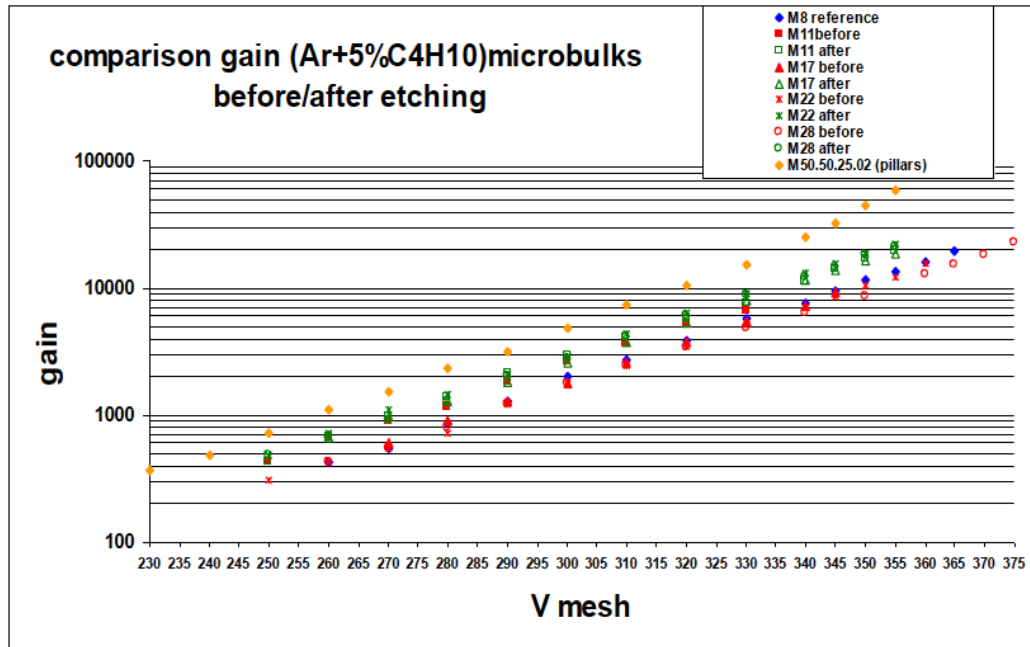

Micro-bulk in CAST - high performance

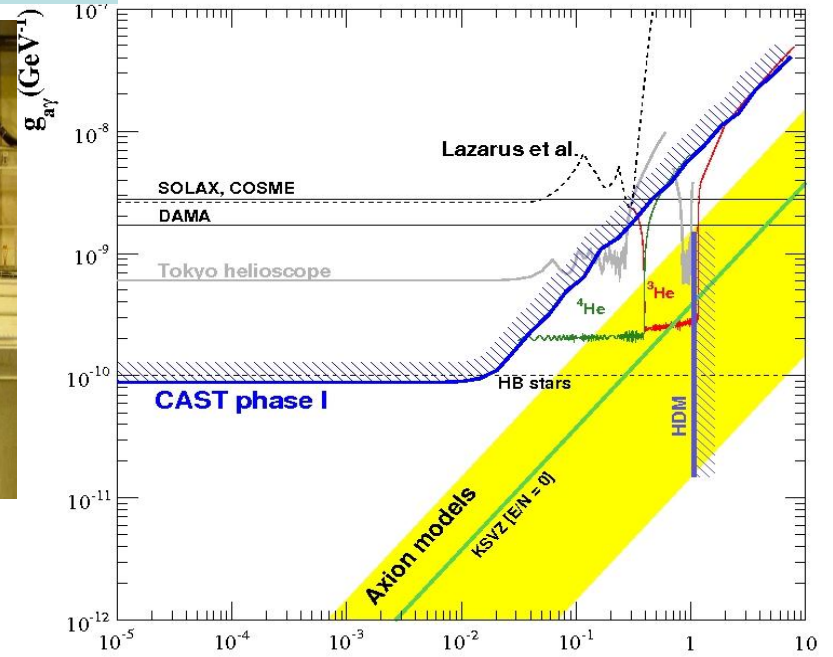
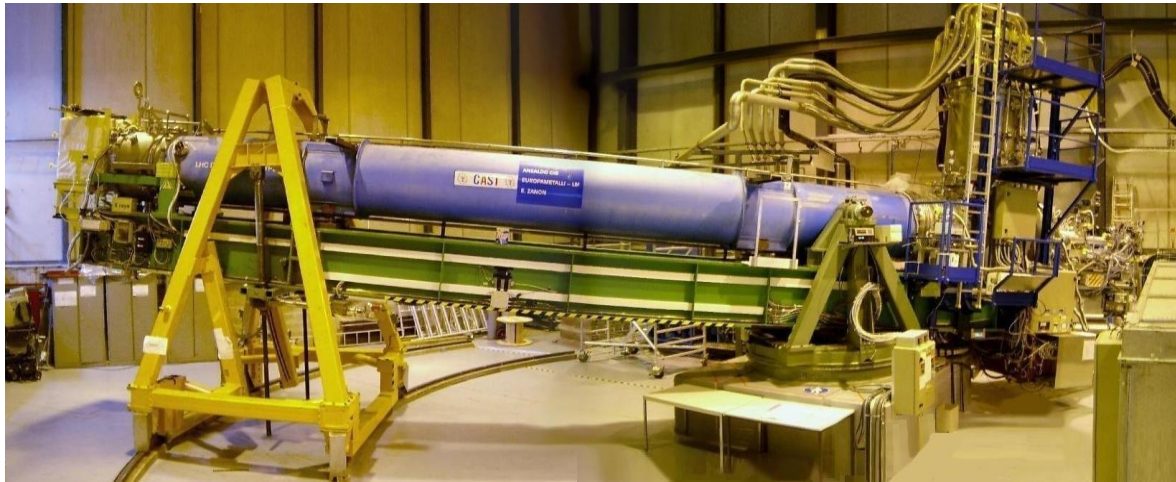

On low radioactivity support

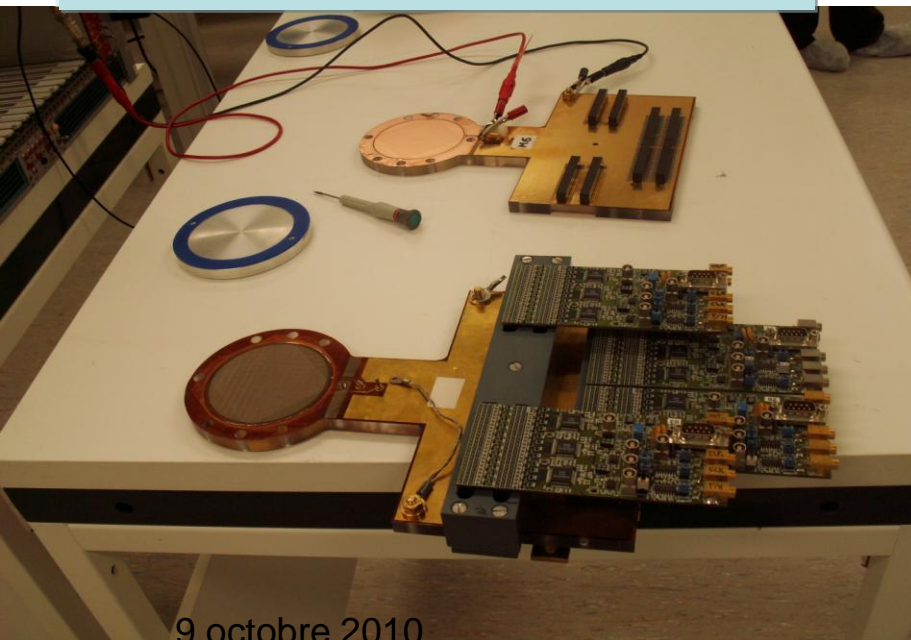

9 octobre 2010

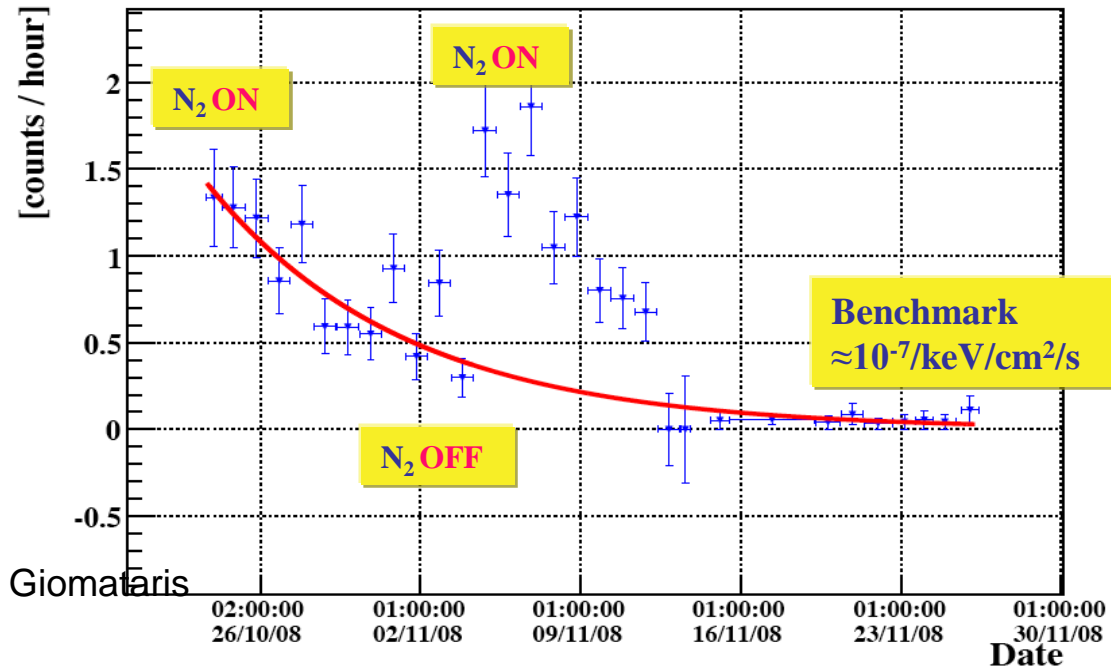

Stability of CAST detector

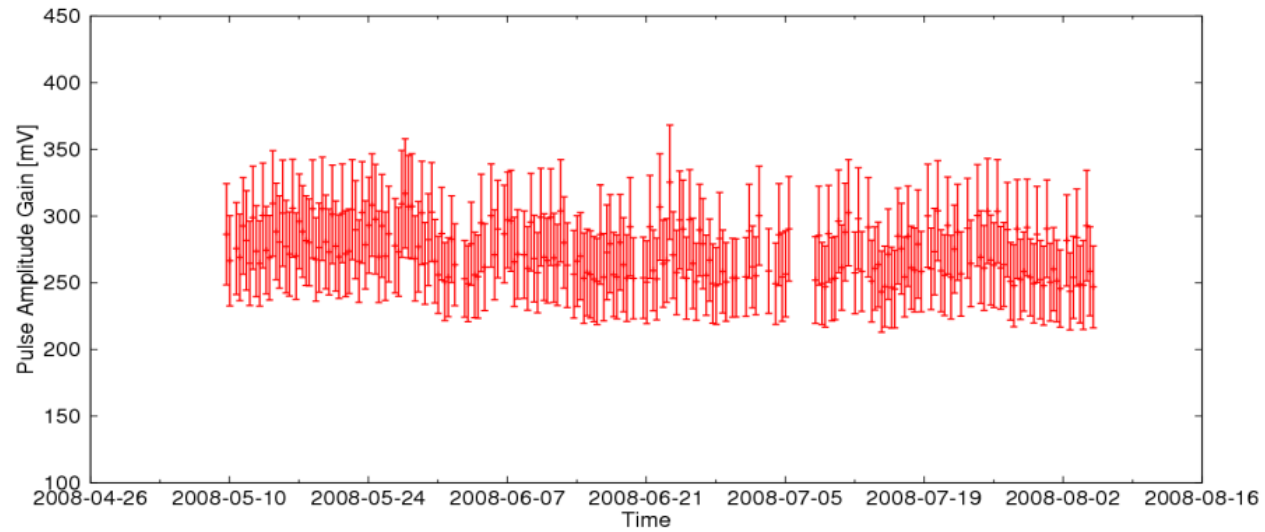

WIMP directional TPCs

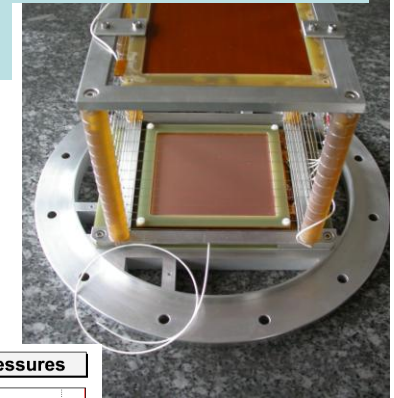
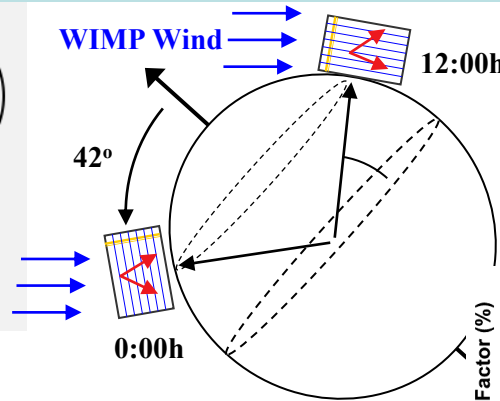
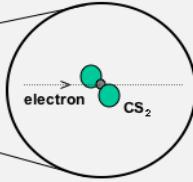
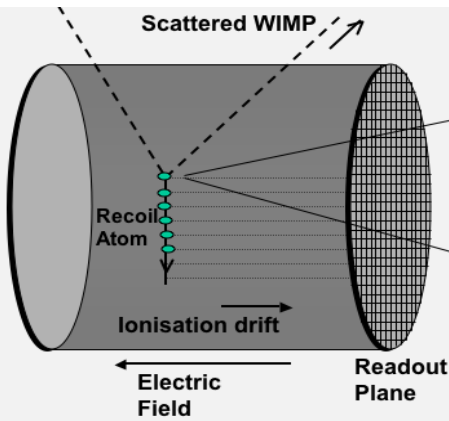

MIMAC-He3 Micro-tpc Matrix of Chambers of He3
 On-baryonic dark matter search, **Micromegas read-out**,
Grenoble – Saclay, Cadarache collaboration

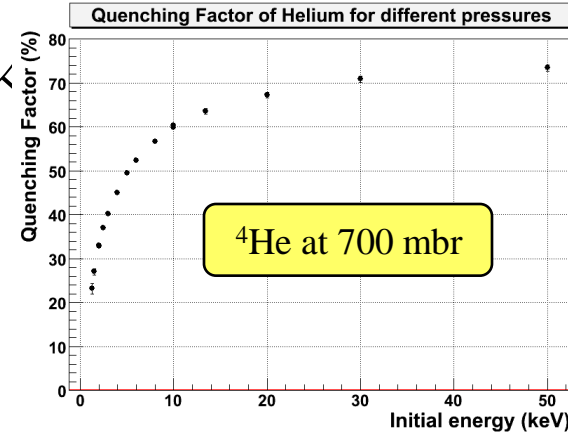

Electrons by 5.9 keV ⁵⁵Fe

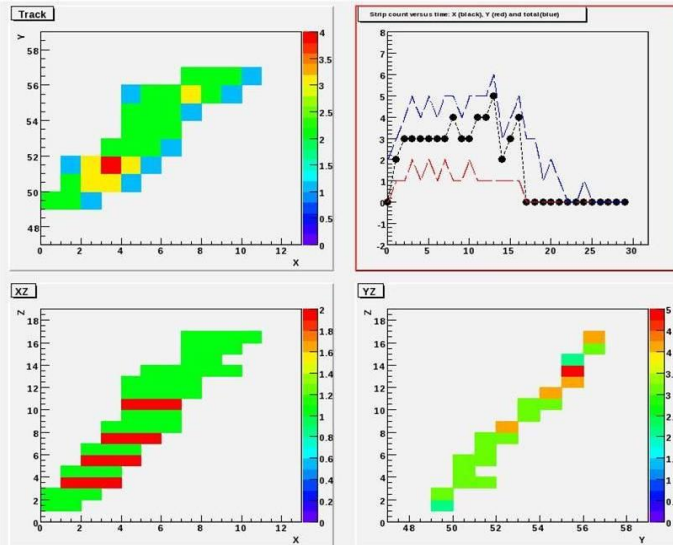

Recoil from 144 keV neutrons

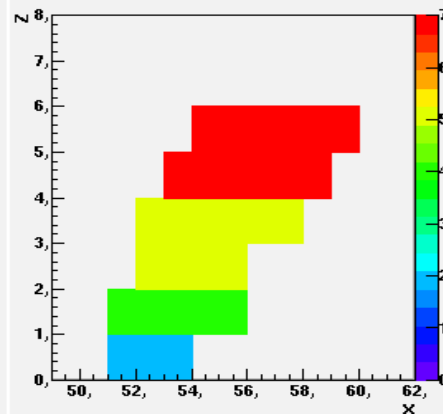

I. Giomataris

100 mbar Isobutane

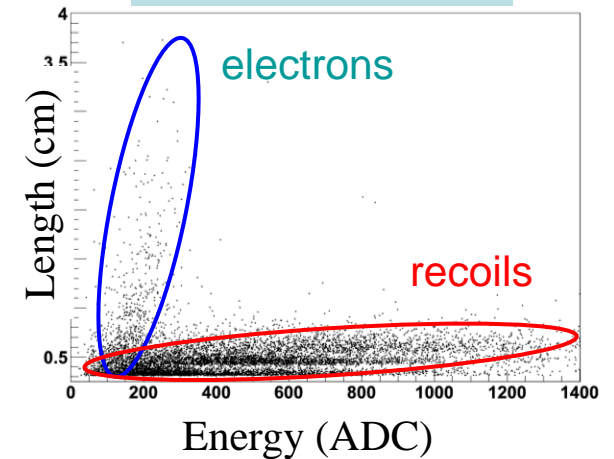

^{241}Am resolution in a small TPC with Micromegas read-out

Saclay, Saragoza, Ottawa collaboration

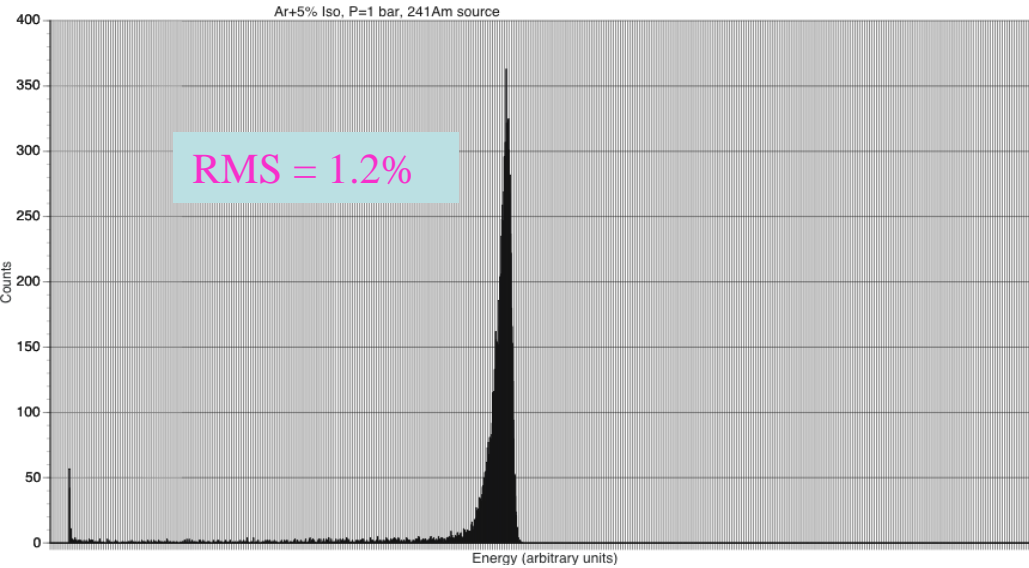

- In Argon energy resolution was constant (RMS=1.2%) up to 4 bar
- We must measure it at higher pressure and in Xenon mixtures
- Neutrinoless Double Beta ($0\nu\beta\beta$) using ^{136}Xe target

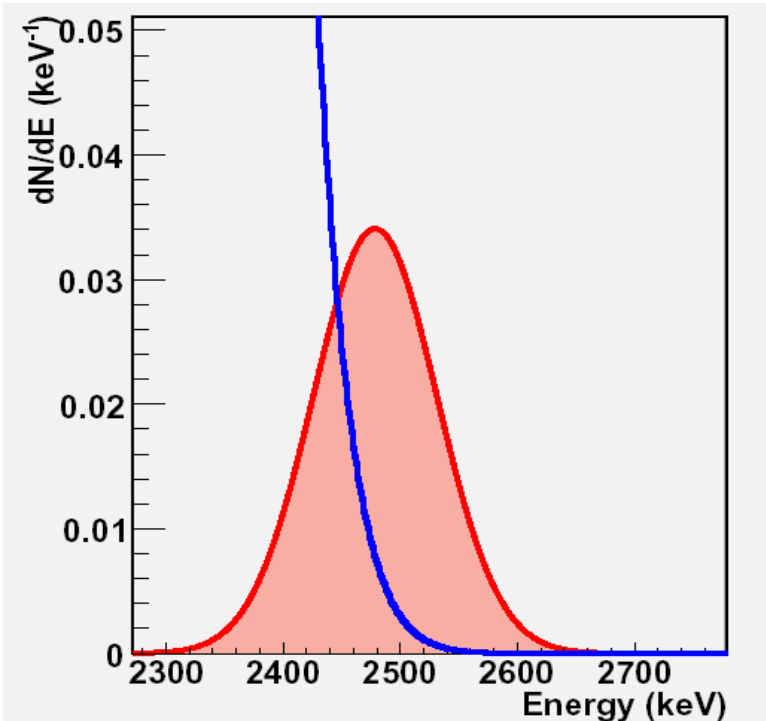
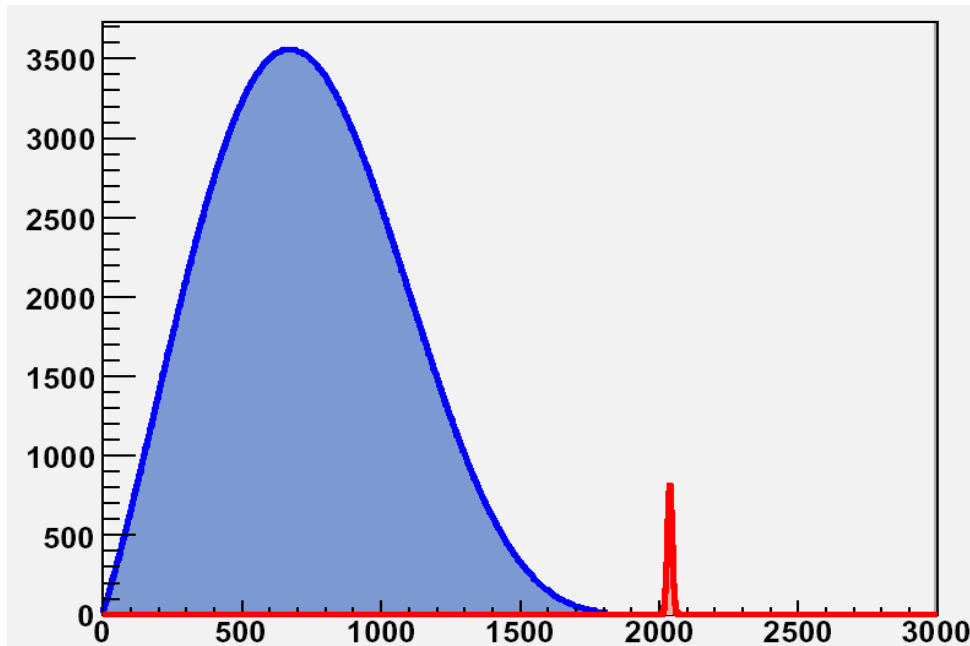

Energy resolution in Xenon 2,3,4,5 bars

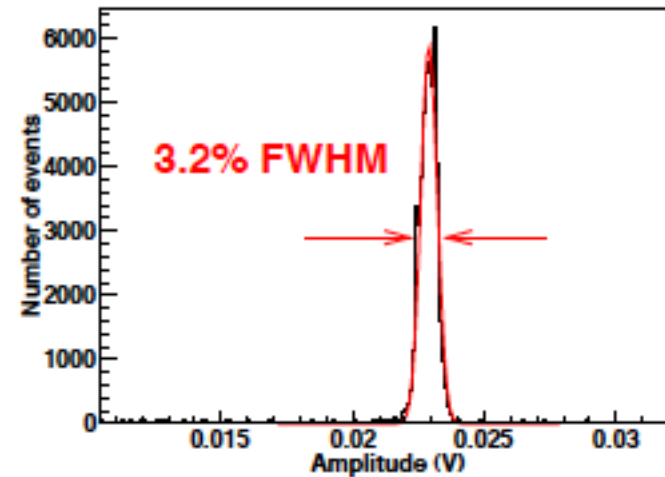
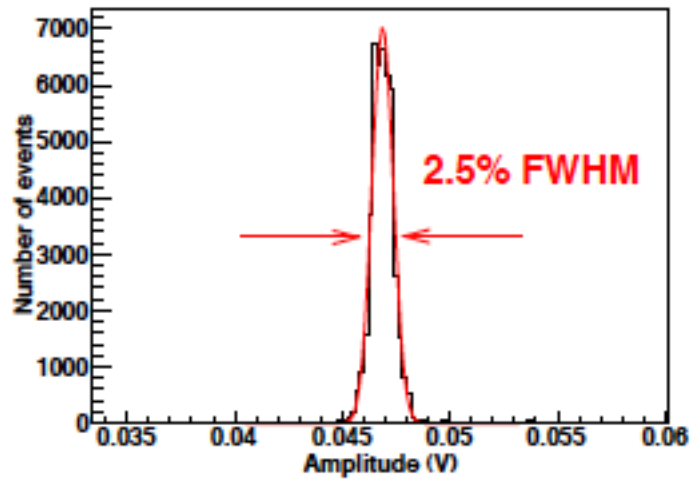
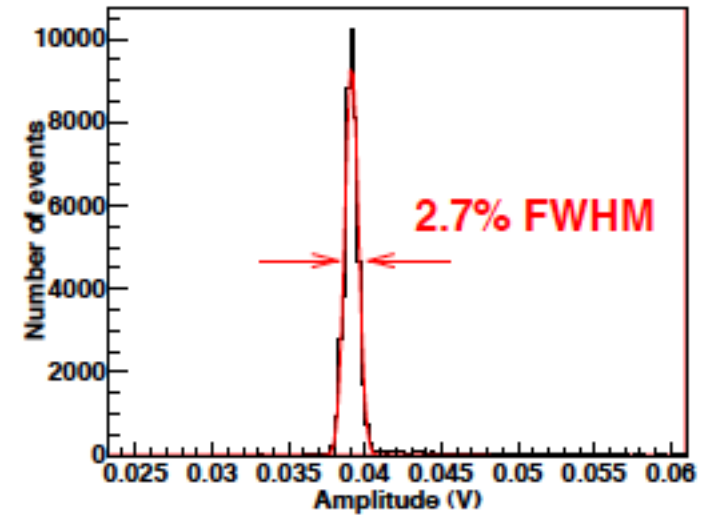
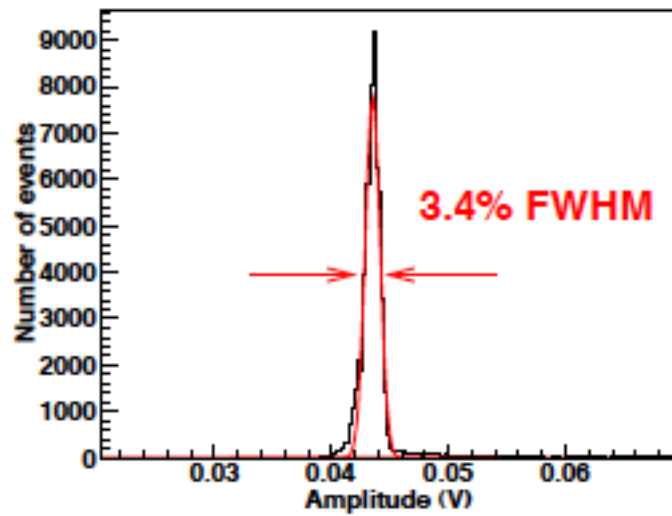

Energy resolution in Argon

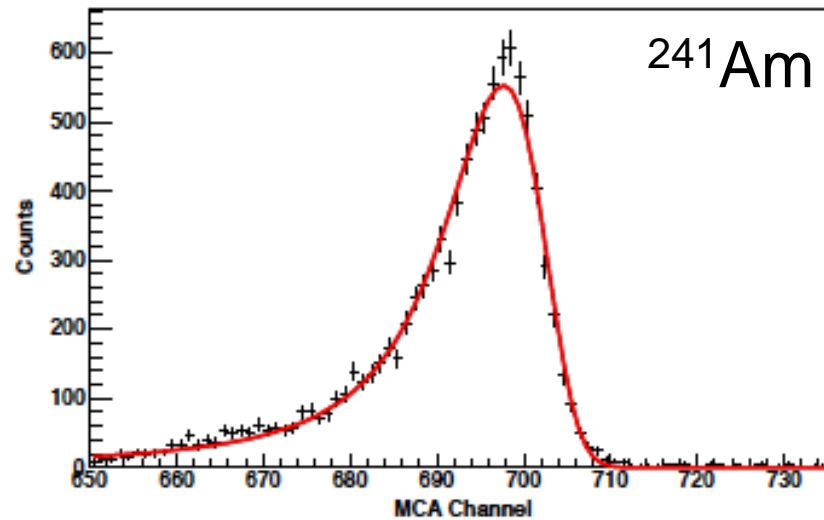
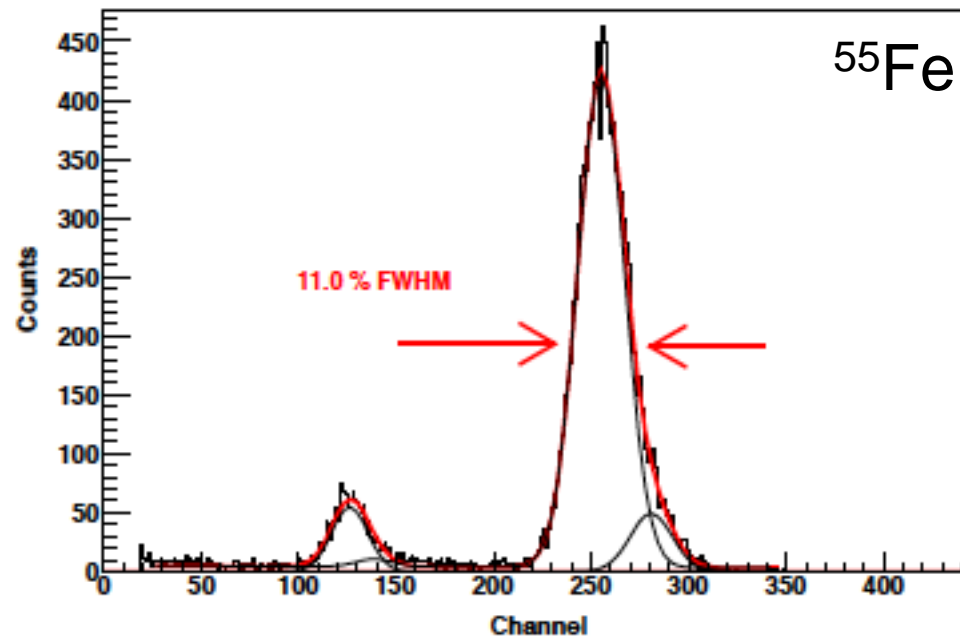
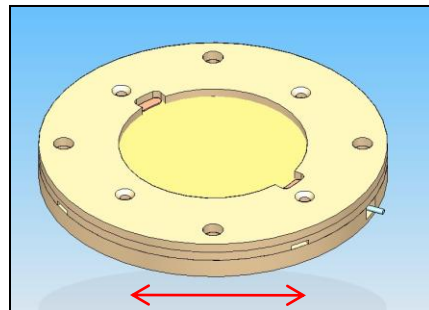
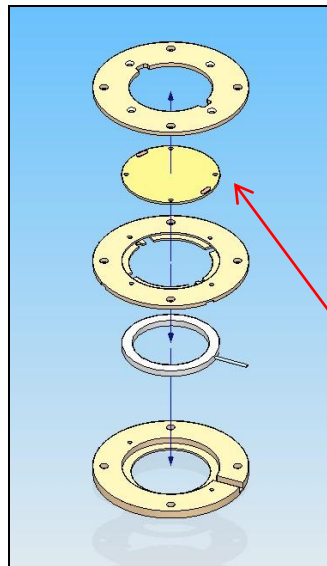
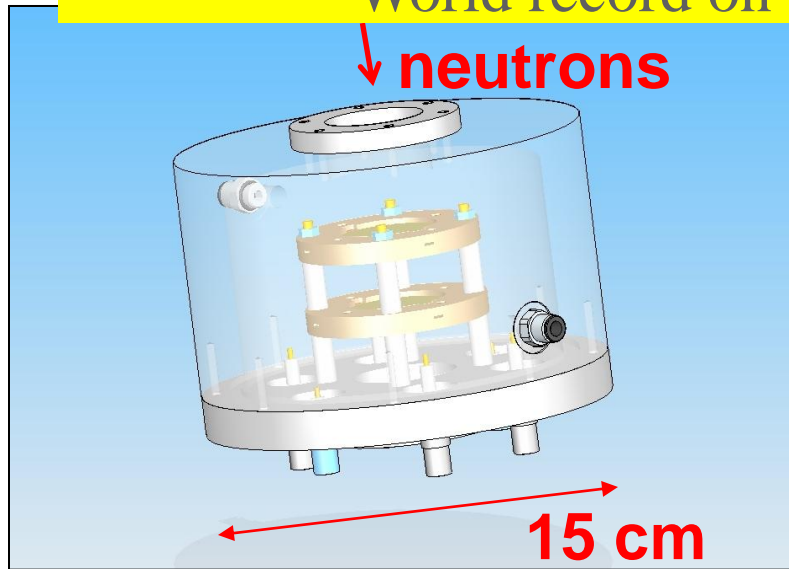

Figure 2. Example of an alpha peak measured in [17], with the fit to a Landau function convoluted with a gaussian. The best fit values for the FWHM of the gaussian component is 0.7%.

MicroMegas neutron flux monitor

World record on low material budget



3.5 cm beam interception
MicroBulk

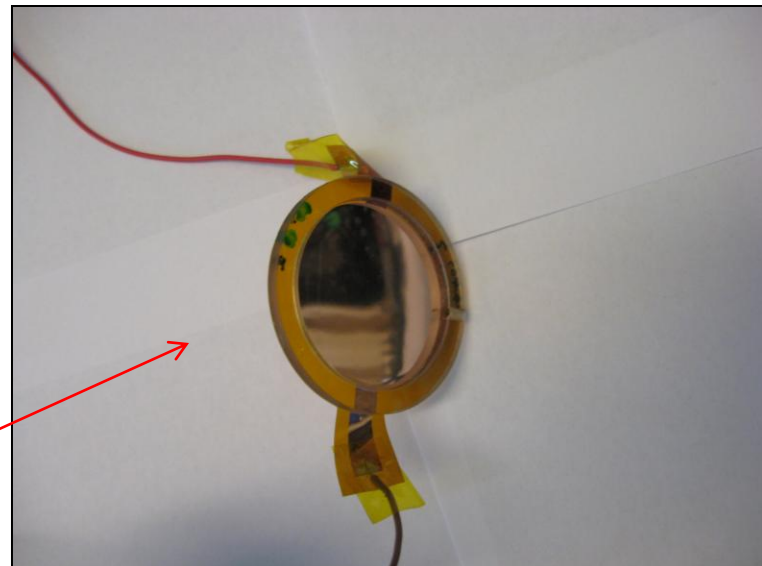

N-TOF neutron flux monitor

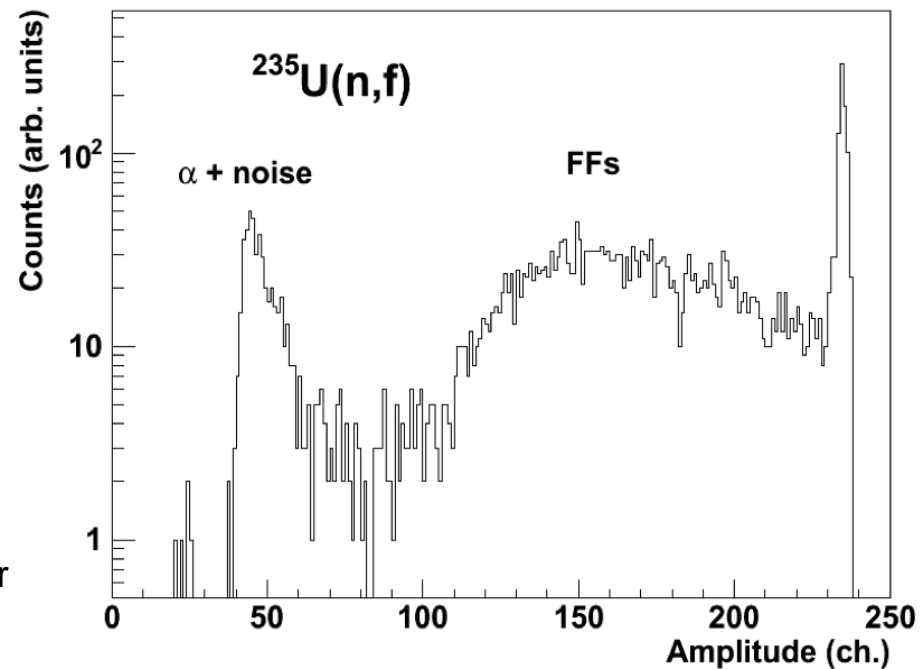
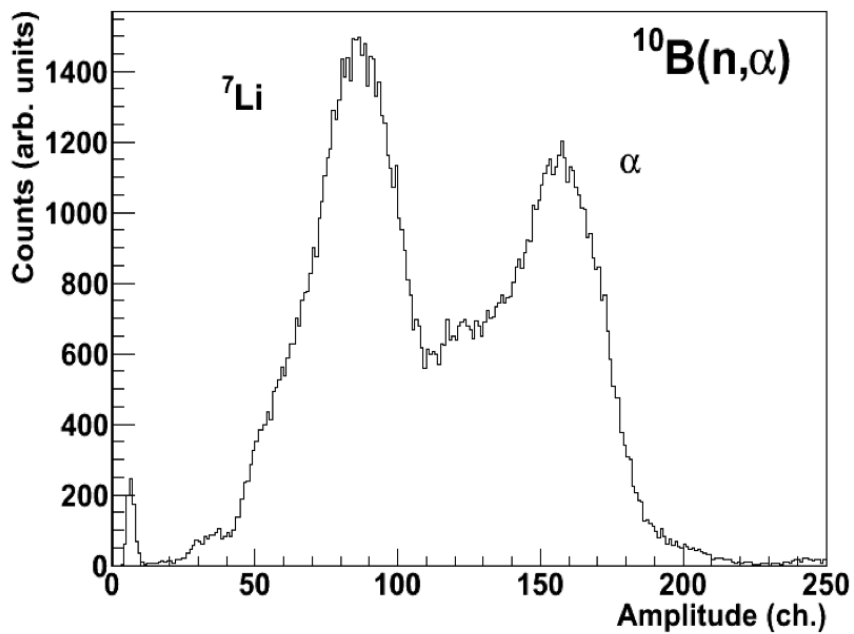
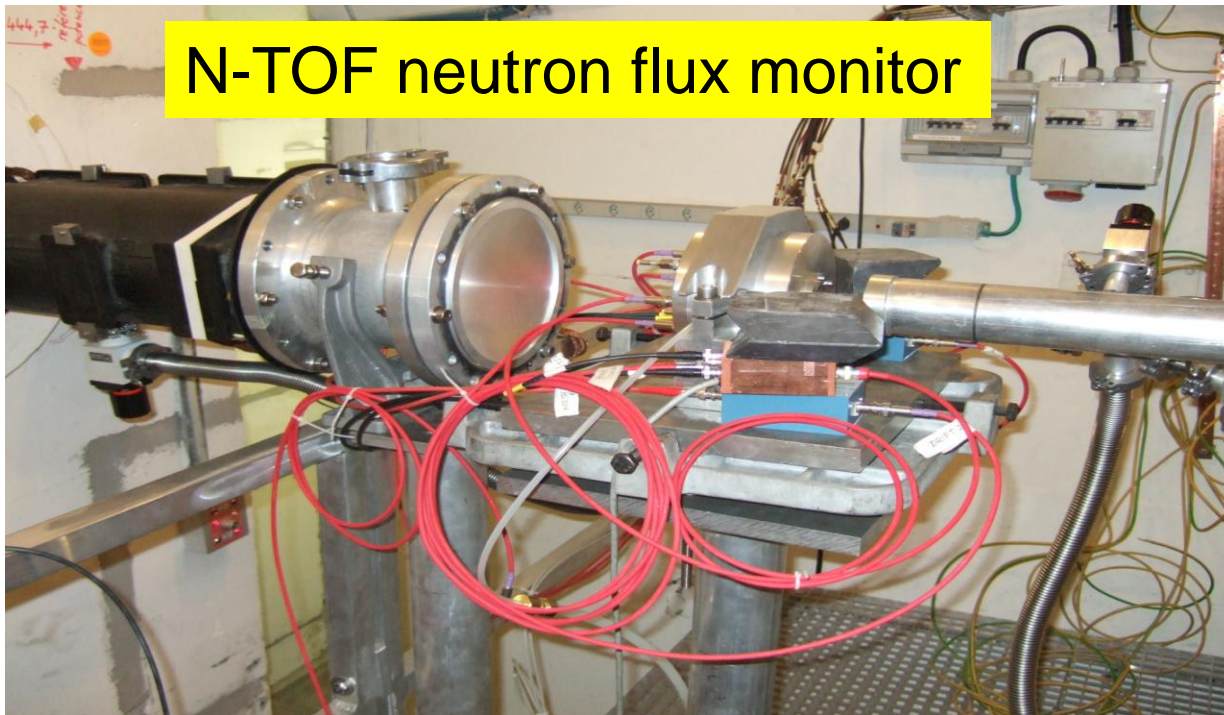

I. Giomatar

N-TOF neutron profile detector

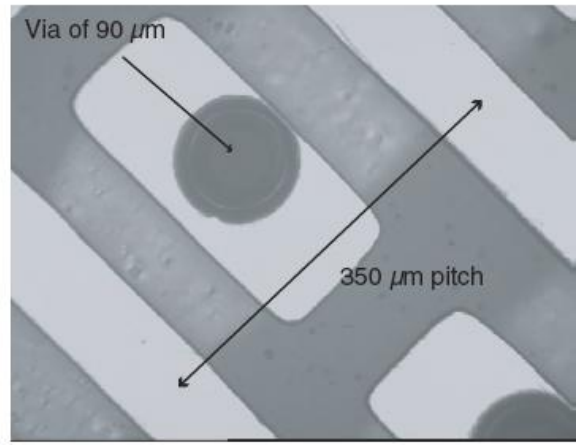
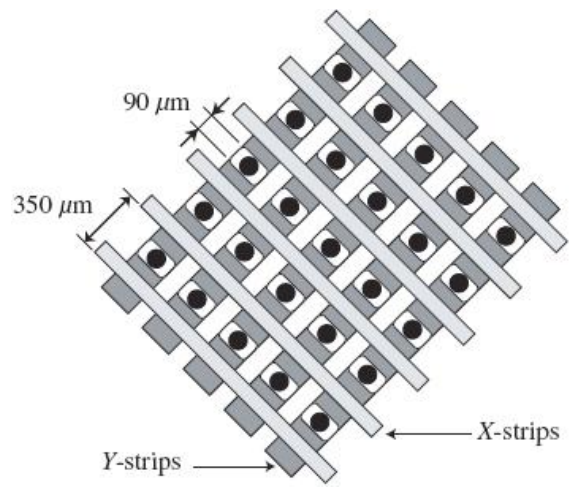
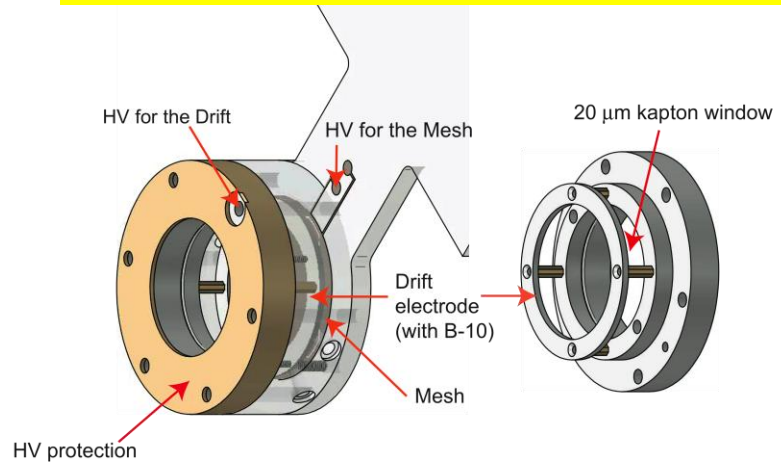

comparison gain

gap 25 microns 50 microns (Ar+5% C4H10)

- ◆ gap 25 microns (n°35)
- gap 25 microns (m25.100.30.01)
- ▲ gap 25 microns (M25.50.25.01 (etched))
- ◆ gap 50 microns (n°29)

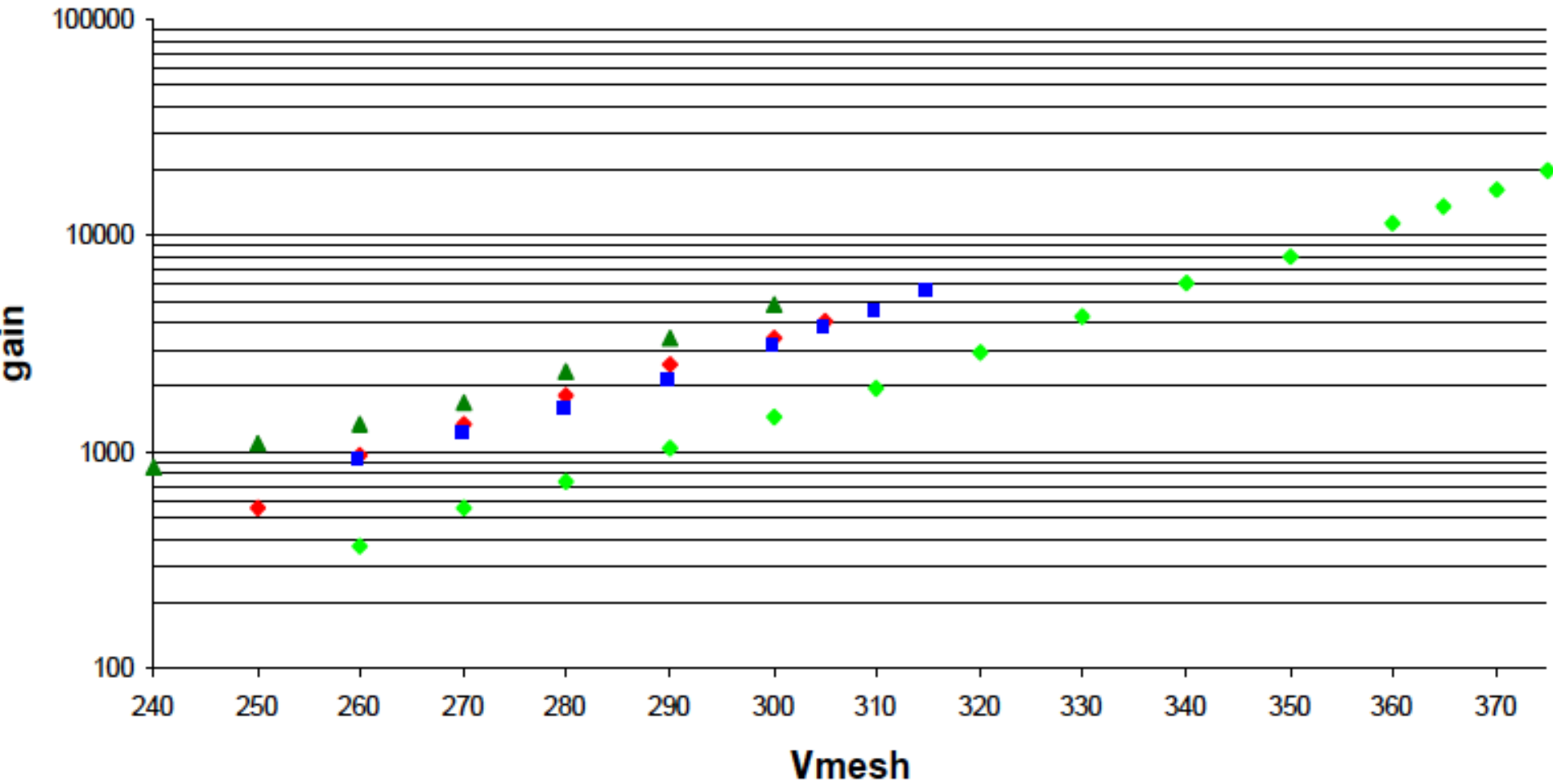

Micromegas operation in high pressure xenon: charge and scintillation readout

C. Balan¹, E.D.C. Freitas¹, T. papaevangelou², I. Giomataris², H. Natal da Luz¹, C.M.B. Monteiro¹, J.M.F. dos Santos¹

¹Instrumentation Centre, Physics Department, University of Coimbra, 3004-516 COIMBRA, Portugal

²Saclay.....

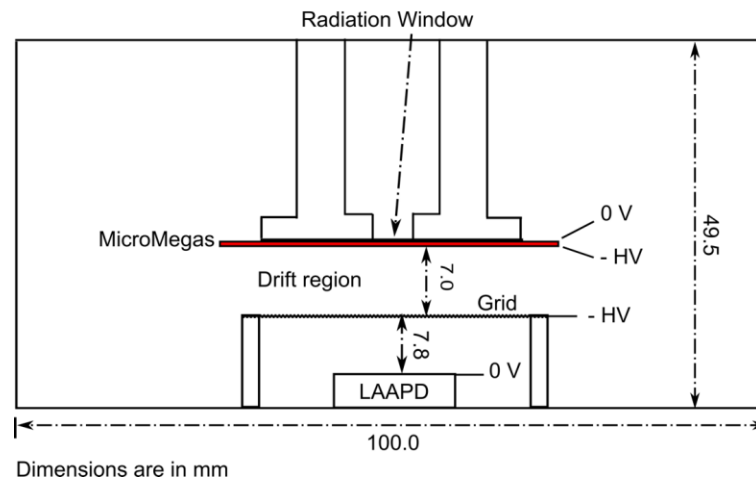

Figure 2- Typical pulse-height distributions obtained for the ^{109}Cd X-ray source; a) for the charge readout channel and b) for the scintillation readout channel.

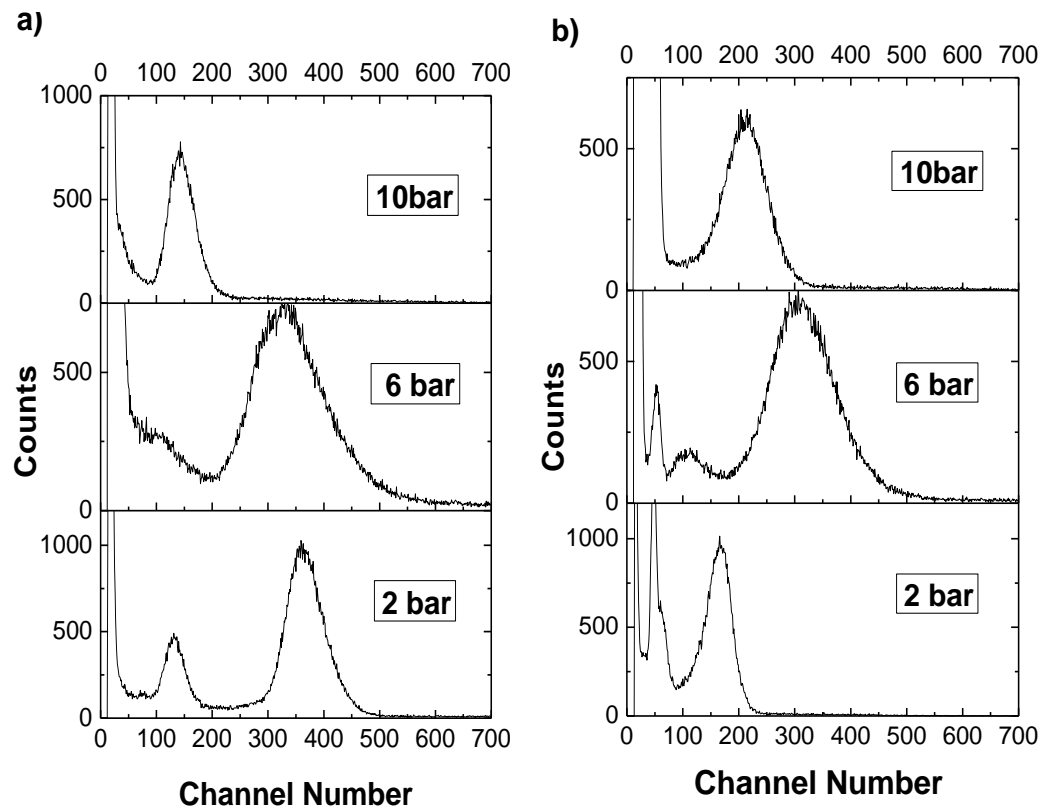
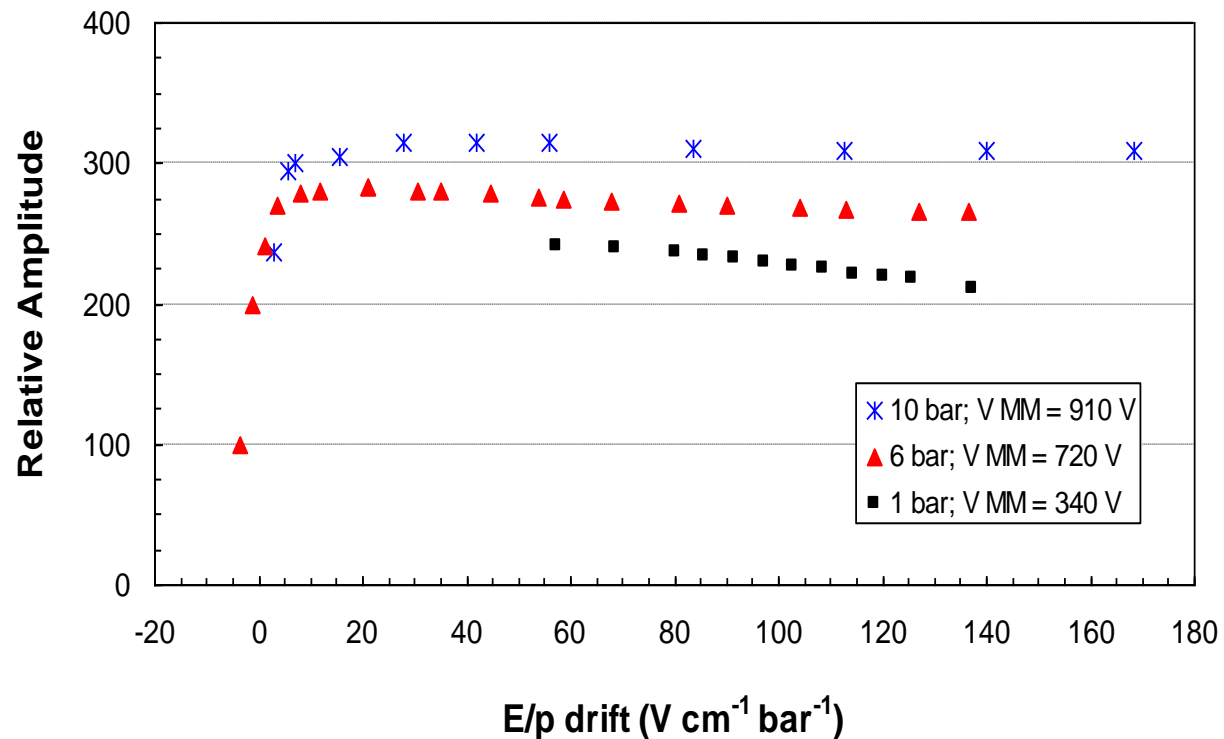

Figure 3- MM relative amplitude as a function of reduced electric field in the drift region



The maximum gain achieved in the scintillation readout channel presents an even smaller dependence with pressure, increasing by a factor of 3 up to 5 bar and, then, decreasing within a factor of two up to 10 bar, as shown in Fig.4b) and Fig.5.

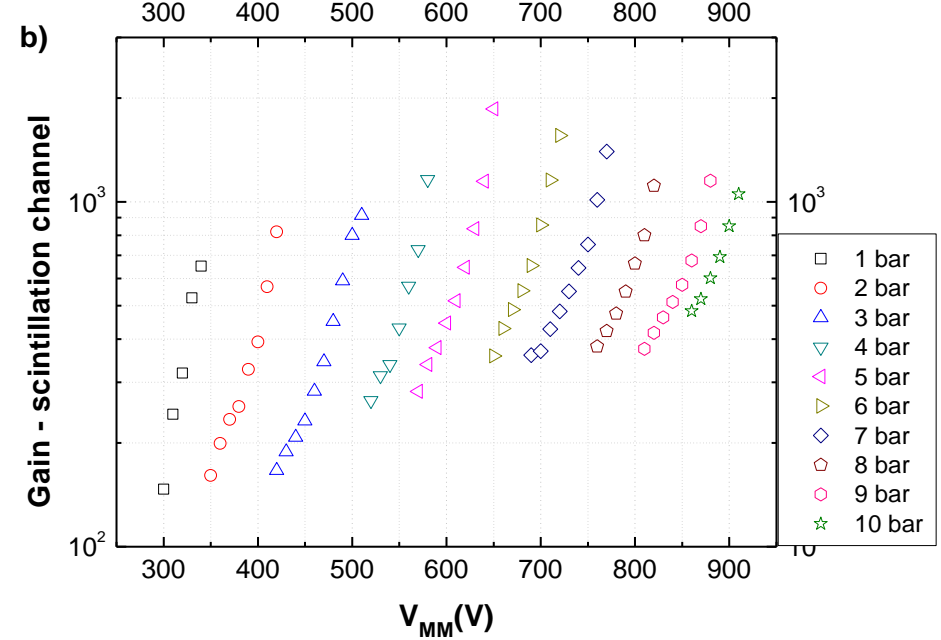
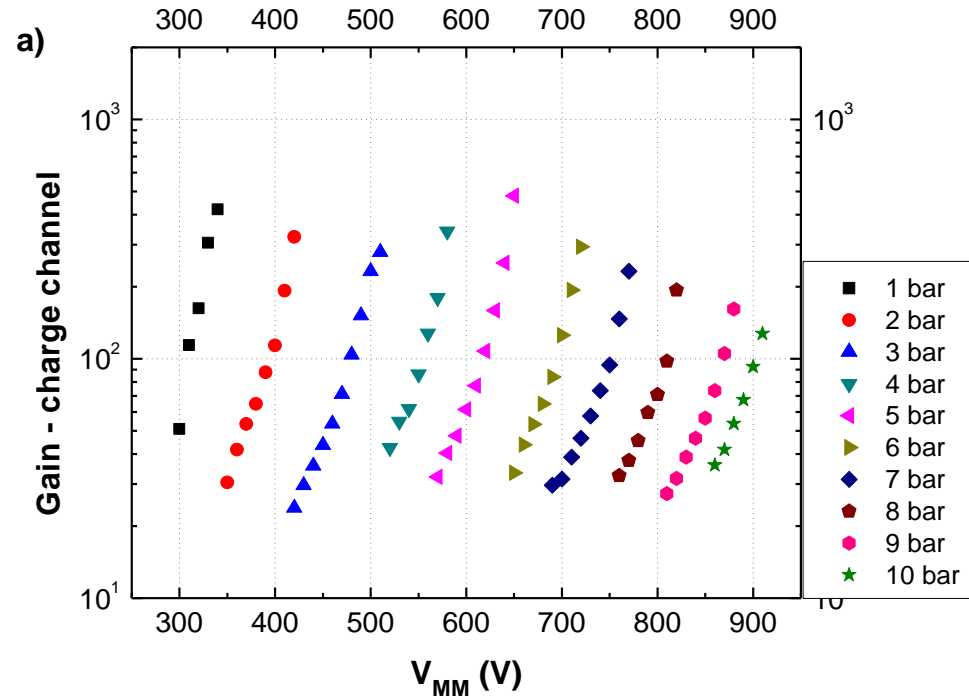
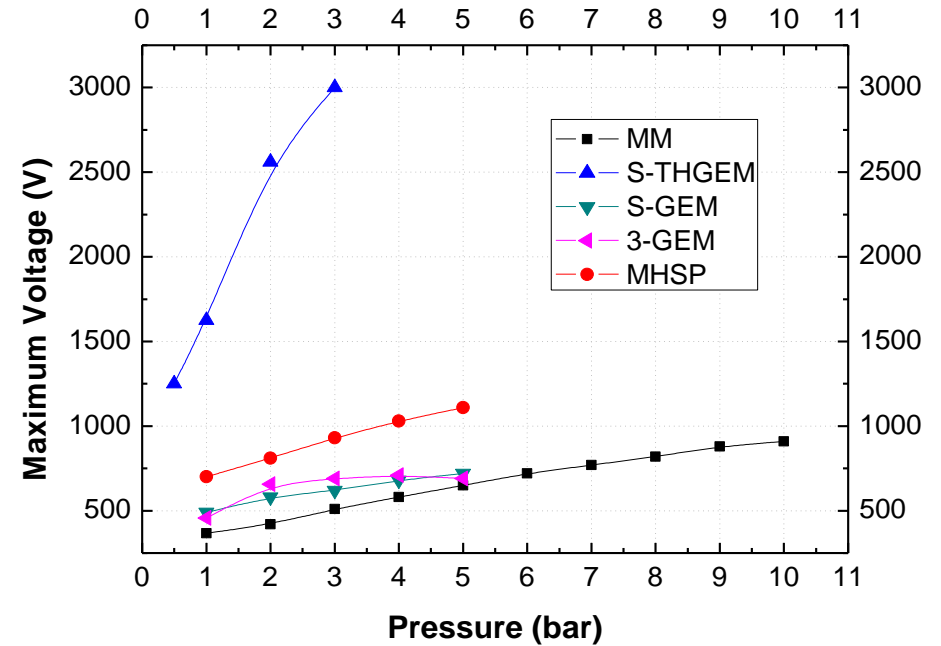
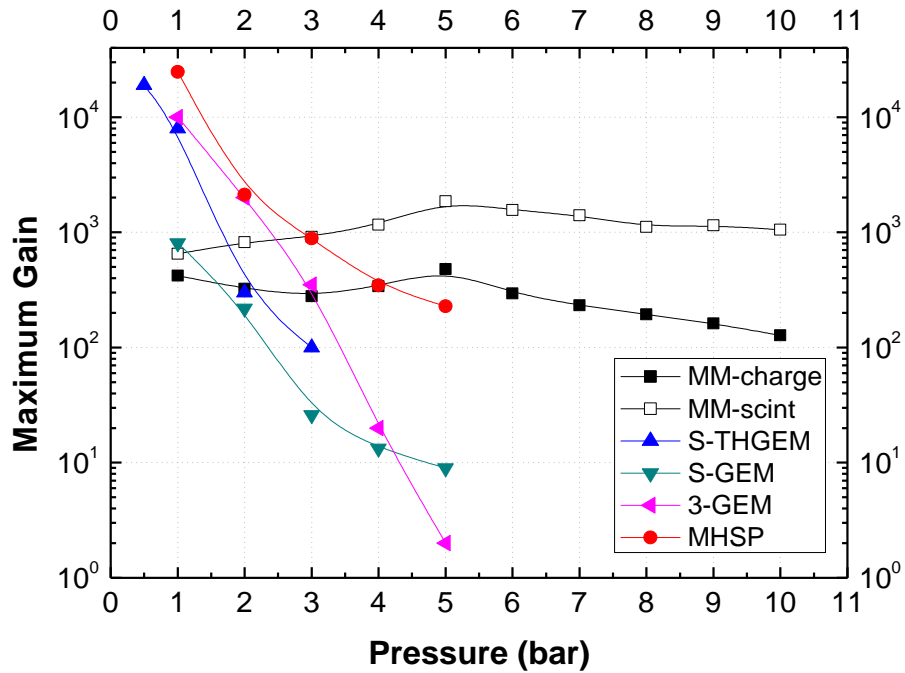

Figure 5 – Maximum gains obtained with the MM for both charge and scintillation readout channels as a function of pressure in the 1 to 10 bar range. For comparison the maximum gains obtained with other micropattern gas electron multipliers are also depicted as a function of pressure: triple-GEM [9], MHSP [10], GEM [11], THGEM [12].



[9] V. Aulchenko et al., *Further studies of GEM performance in dense noble gases*, Nucl. Instr. Meth. A 513 (2003) 256 and references therein.

[10] F.D. Amaro et al., *Operation of MHSP multipliers in high pressure pure noble-gas*, J. Inst. 1 (2006) P04003.

[11] A.S. Conceição, et al., *Operation of a single-GEM in noble gases at high pressures*, 2007 J. Inst. 2 P09010.

[12] R. Alon et al., *Operation of a Thick Gas Electron Multiplier (THGEM) in Ar, Xe and Ar-Xe*, J. Inst. 3 (2008) P01005.

Figure 9 – Detector energy resolution for the 22.1 keV as function of MM biasing voltage and for the different xenon pressures: a) charge readout channel, b) scintillation readout channel.

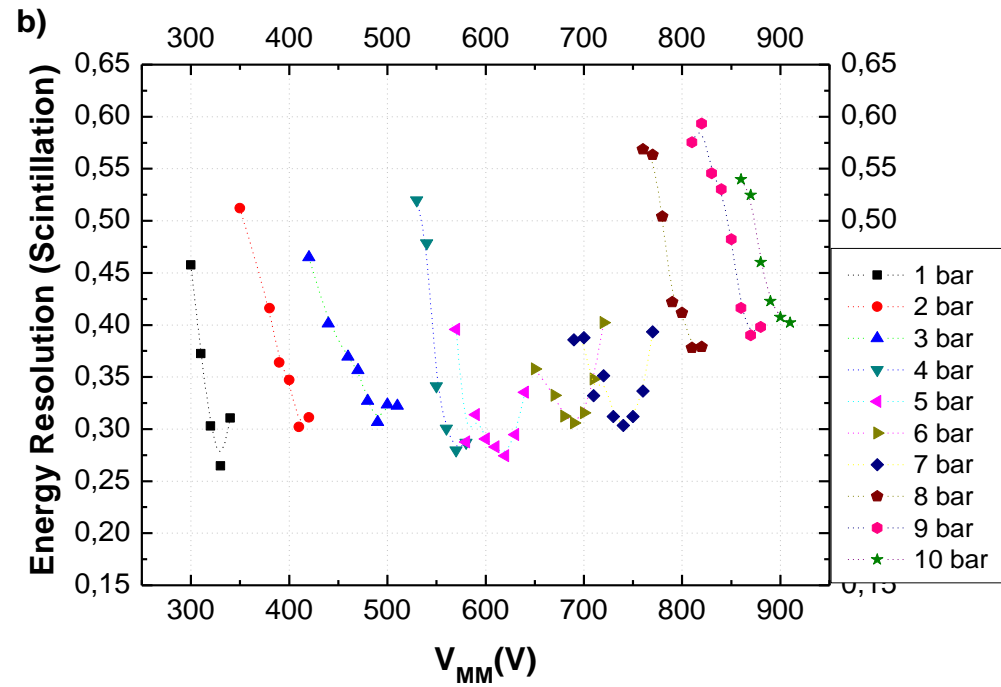
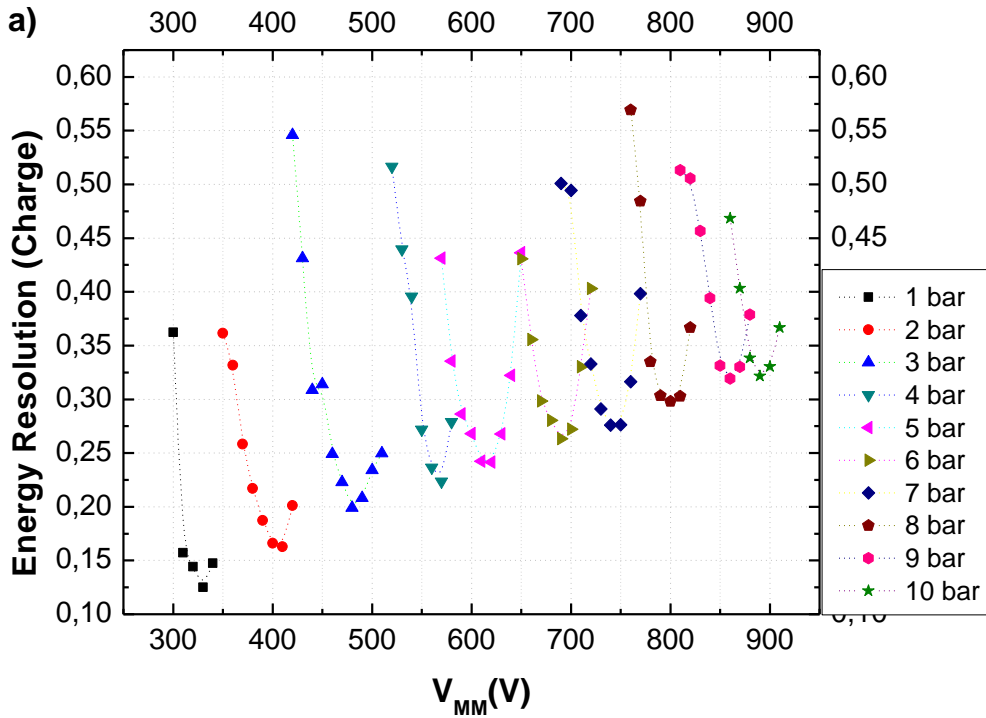
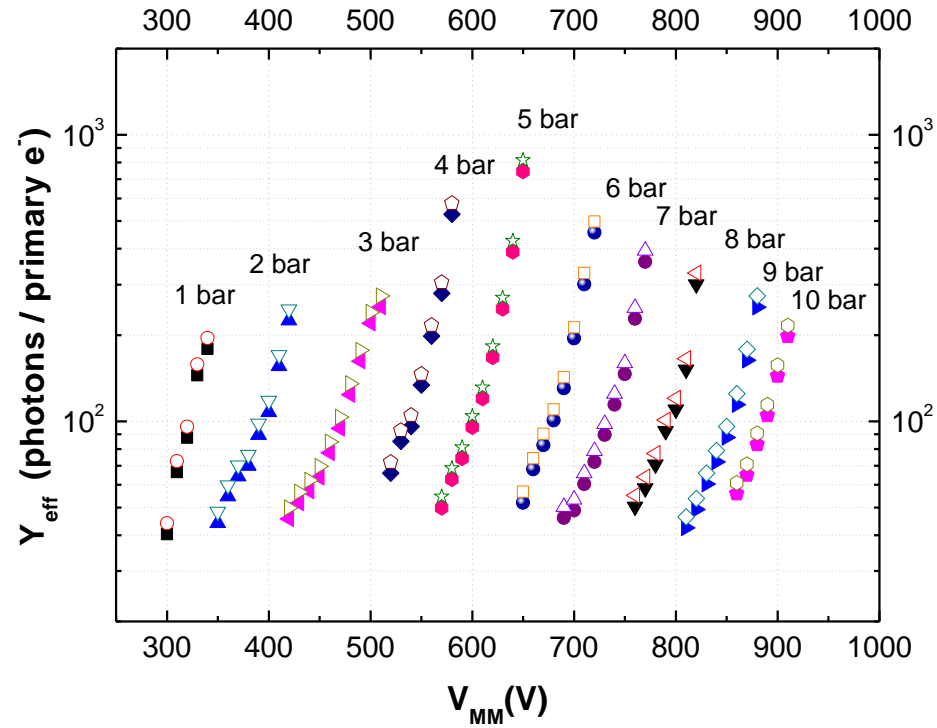

Figure 11 – Effective scintillation Yield, i.e. number of photons emitted from the MM per primary electron produced in the drift region, as a function of MM biasing voltage. Solid symbols: using direct X-ray interactions in the LAAPD as a reference; open symbols: using the gain calibration of the electronic chain and an LAAPD gain of about 30.



Future developments of micro-Bulks

Very high priority of our group

- Improve robustness
- Larger surfaces
- Further decrease material (<10% of a silicon detector)
- Decrease capacity
- Increase optical transparency
- Push mesh technology (1000-2000 LPI?)
- Smaller amplification gaps (<10microns?)
- Spark protection
- Segmentation for spark protection
- Novel X-Y structure
- Light emission study, photodetection,