

ATHENA

A Totally Hermetic Electron-Nucleus Apparatus

A new EIC experiment at IP6 at BNL

<https://sites.temple.edu/eicatip6/>

Daria Sokhan



University
of Glasgow



Irfu - CEA Saclay
Institut de recherche
sur les lois fondamentales
de l'Univers

UK EIC Meeting – 17th June 2021

Organisation

Monthly EIC project meetings joint with reps from all proto-collaborations.

ATHENA meetings are fortnightly: Thursday 4pm UK time – next meeting 24th June

Also a monthly meeting at 1am UK time aimed at collaborators in Asia.

Detector WGs:

Tracking - Laura Gonella
(Birmingham) co-convener

PID

Calorimetry

Far-forward

Far-backward

Polarimetry

Physics Validation WGs:

Inclusive – Paul Newman
(Birmingham) co-convener

Semi-inclusive

Exclusive / Tagging – Daria Sokhan
(Glasgow) co-convener

Jets / HF / EW-BSM

Common far-forward and far-backward meetings with all proto-collaborations.

Software & Computing WG: Bi-weekly meetings, tutorials

Proposal Committee - Peter Jones (Birmingham) on the team

Charter drafted (Daria Sokhan, Glasgow, on the team) – review stage, adoption vote at next bi-weekly meeting.

Mailing lists / find meeting info: <https://sites.temple.edu/eicatip6/working-groups/>

Timeline overview

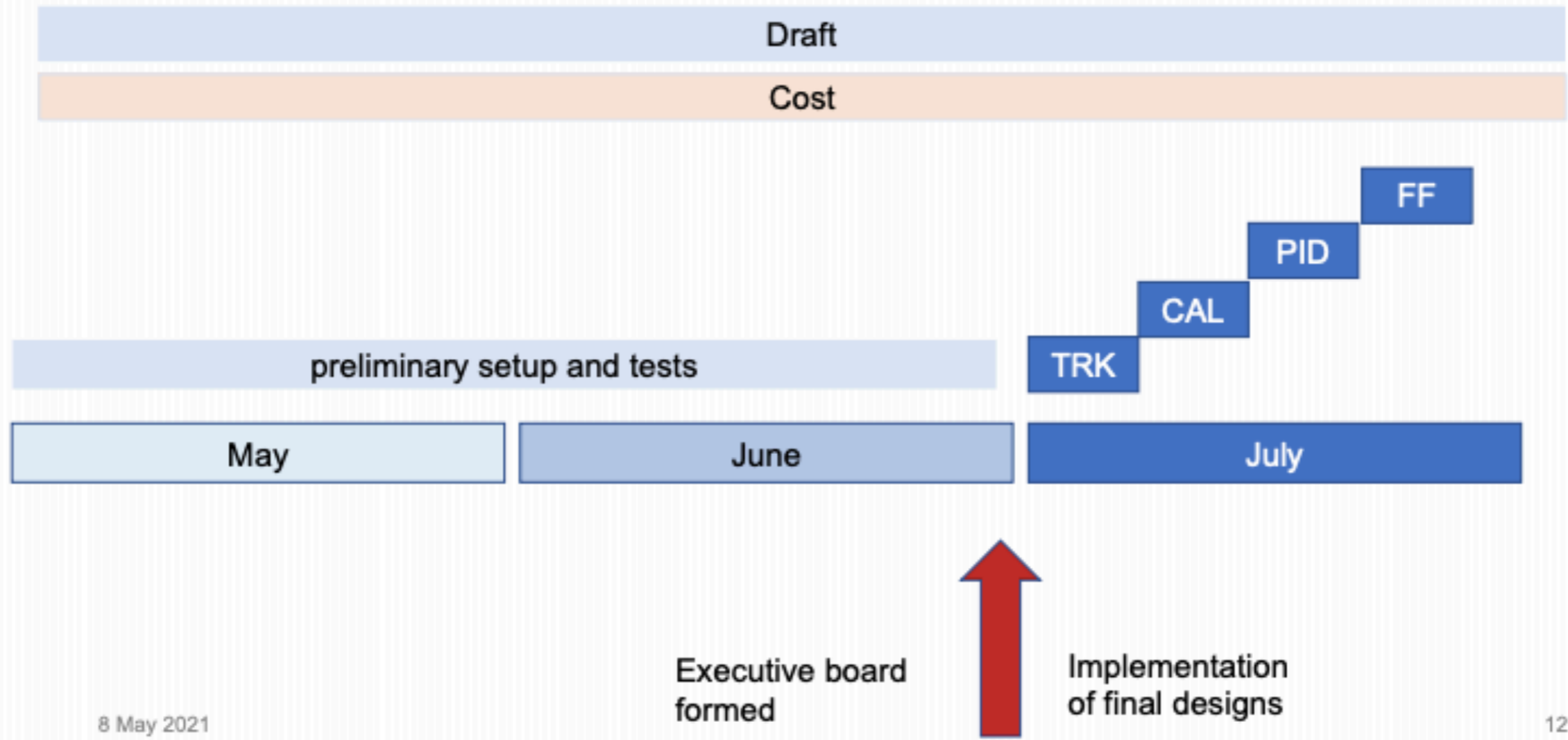

8 May 2021

12

Silvia Dalla Torre and Yulia Furletova

Timeline overview

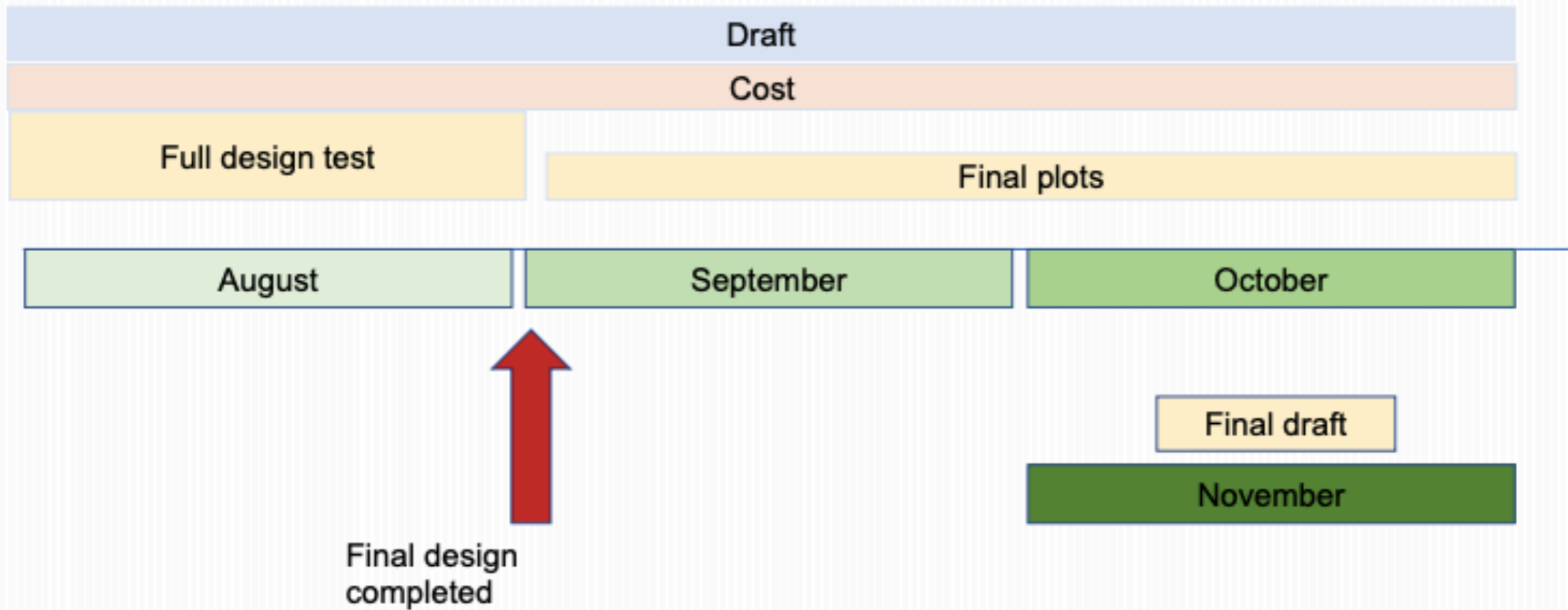

Magnet: variable strength (1.5T - 3T)

NEW YOKE FOR HCAL

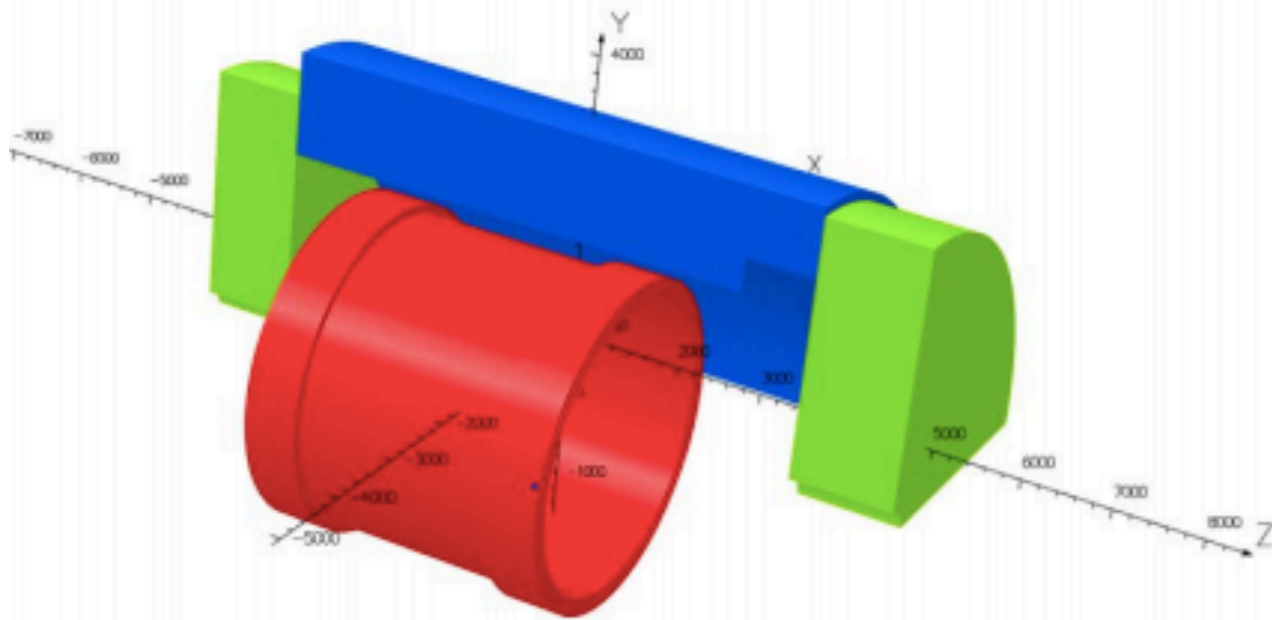

HELMOLTZ COILS

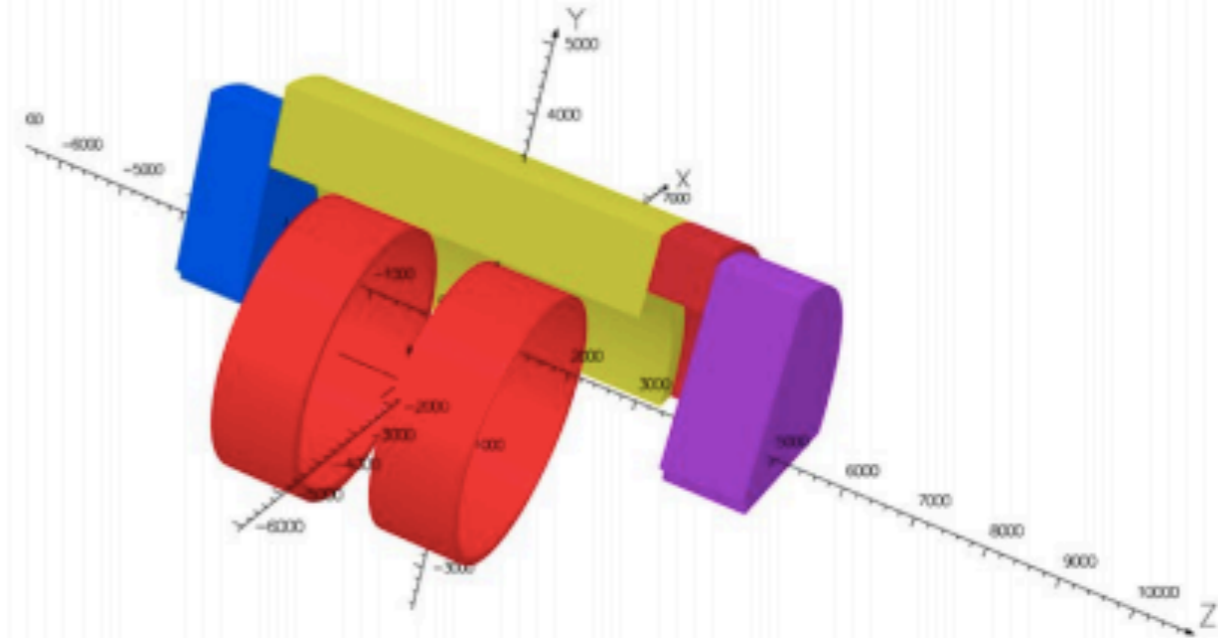

M. Calvelli

Second version of 3T field map released, solenoid design options under investigation.

- Max $B_{IP} = 3.0$ T
- Bore Diameter = 3.2 m
- Length ≈ 3.6 m
- Homogeneity tracker region = 10%
- Homogeneity TPC region = 5%
- Projectivity RICH for $1.5 \leq \eta \leq 3.5$
- *field lines parallel to particles trajectories*

Software

Full detector being implemented into DD4HEP:

- ❖ ECAL, HCAL implemented,
- ❖ Far-forward work in progress,
- ❖ Far-backward needs implementing,
- ❖ PID (RICH-and-friends) in various stages of implementation,
- ❖ Tracking in good shape.

First large-scale simulations: PYTHIA8 DIS, 25mrad and 35mrad crossing angles.

Gathering info on computing resources: <https://docs.google.com/spreadsheets/d/1FpzI20WqMalhbOqeGEiJMsXRwAvzisWRjCMfOHasUz0/edit#gid=0>

Most recent summaries on different **detector systems and physics processes:**

<https://indico.bnl.gov/event/12132/>

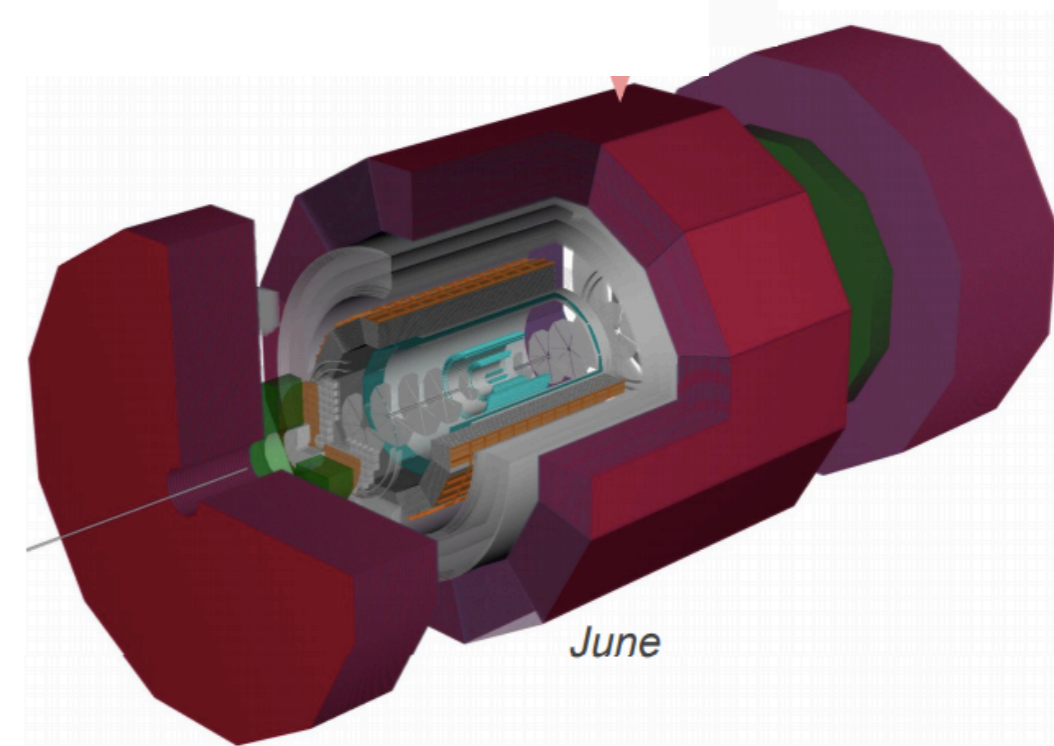

**Next bi-weekly meeting:
Thurs 24th June, 4-6pm (UK time)**

<https://sites.temple.edu/eicatip6/calendar/collaboration-calendar/>