

# **Basics of Beam Dynamics in Circular Accelerators**

## **Part 1**

**Based on P.G.Bryant and B.Holzer**

**CERN Accel. School-2008**

**as well as**

**L.Rinolfi -- CERN Accel.School-2000**

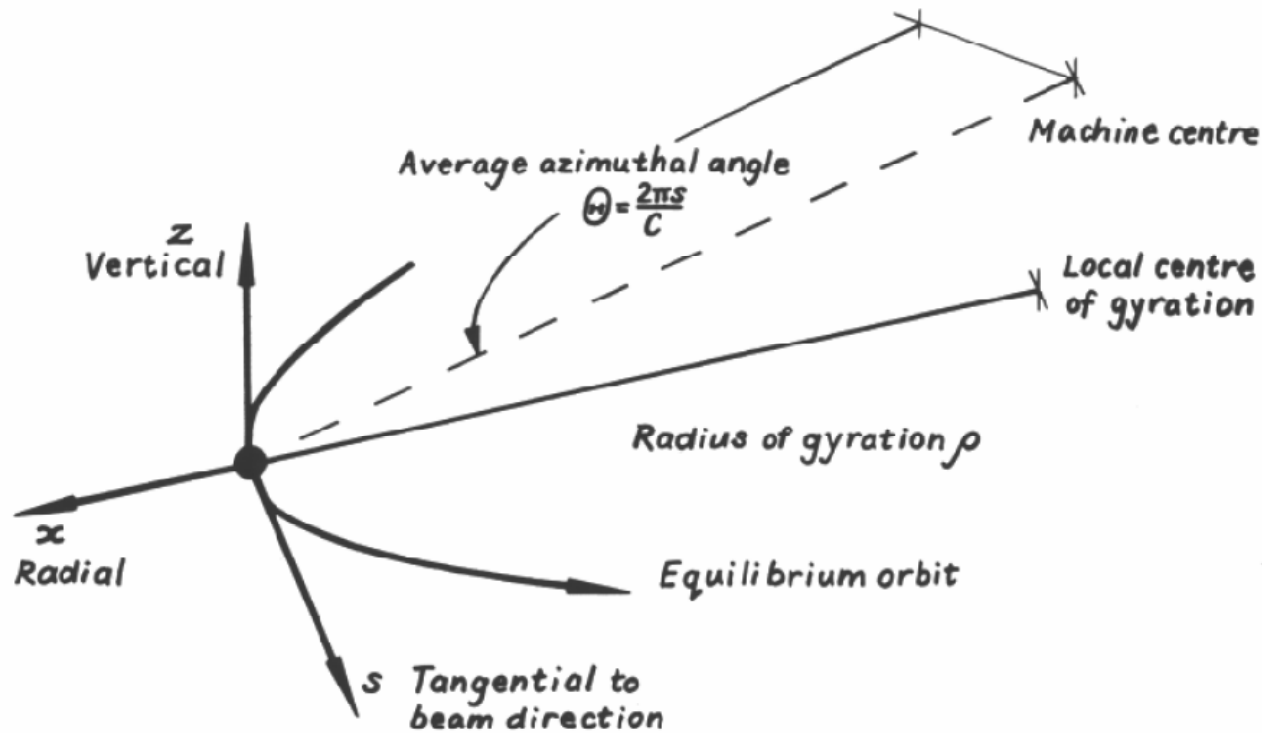

- ❖ The tangential co-ordinate, which is directed along the central orbit, is designated as 's' (distance along beam).
- ❖ Note that 'y' will be used as a general co-ordinate that can be either 'x' (horizontal) or 'z' (vertical).

# Terminology

- ❖ In general, an *accelerator lattice* comprises a series of magnetic and/or electrostatic and/or electromagnetic elements separated by field-free, drift spaces.
- ❖ In most cases, the lattice is dominated by magnetic dipoles and quadrupoles that constitute what is called the *linear lattice*. Quadrupole and higher order lenses are usually centred on the orbit and do not affect the geometry of the accelerator.
- ❖ The trajectory followed by the reference ion is known as the *equilibrium* or *central orbit*.
- ❖ In a ‘ring’ lattice, the enforced periodicity defines the equilibrium orbit unambiguously and obliges it to be closed. For this reason, it is often called the *closed orbit*. In transfer lines, there is an extra degree of freedom and the designer is required to specify a point on the 6-dimensional  $(x, x', s, dp/p, z, z')$  trajectory.
- ❖ Ions of the same momentum as the reference ion, but with small spatial deviations will oscillate about the equilibrium orbit with what are known as *betatron oscillations*.
- ❖ Ions with a different momentum will have a different equilibrium orbit that will be referred to as an *off-momentum* or *off-axis equilibrium orbit*. Off-momentum ions with small spatial errors will perform betatron oscillations about their off-momentum equilibrium orbit.

# Example of RACETRACK Lattice

## Electrostatic Antiproton Recycling Ring (AD-REC)

### QUASAR Design for AD MUSASHI experiment

Is it not similar to Ring with magnetic elements ?

Fixed-Energy Ring

circumference = 7.2 m

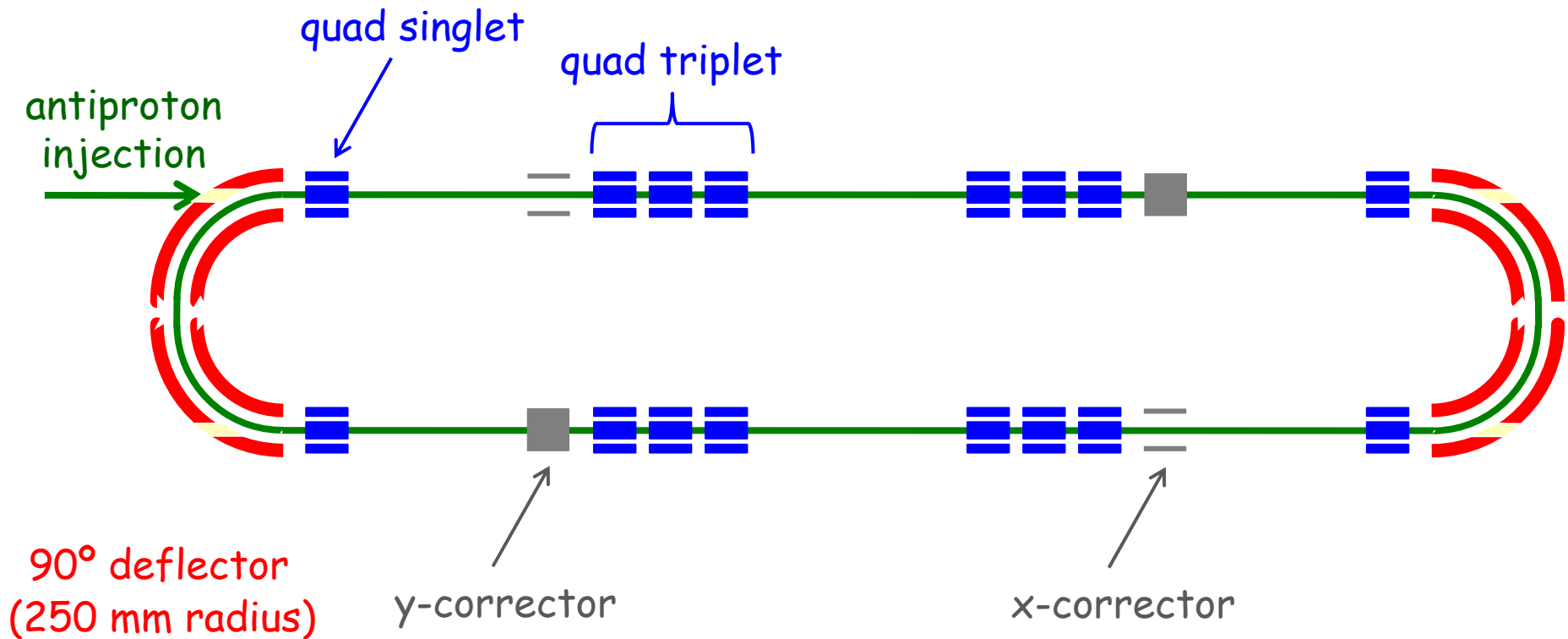

Ring parameters	
Ions	pbars
Test ions	H <sup>-</sup>
Energy Range	<b>3 keV (?)</b>
Type	electrostatic
Beam intensity	5•10 <sup>5</sup> ions
Circumference	5.9348 m
Straight sections	2
Straight section length	1300 mm
Ring acceptance	80 $\pi$ mm•mrad
Vacuum	10 <sup>-11</sup> torr
Ion rotation frequency	128 to 37 kHz
Ion rotation period	7.8 to 27 $\mu$ s
<b>Operation time</b> 500 000 turns	4 – 14 s

## AD-RECYCLER Ring Layout

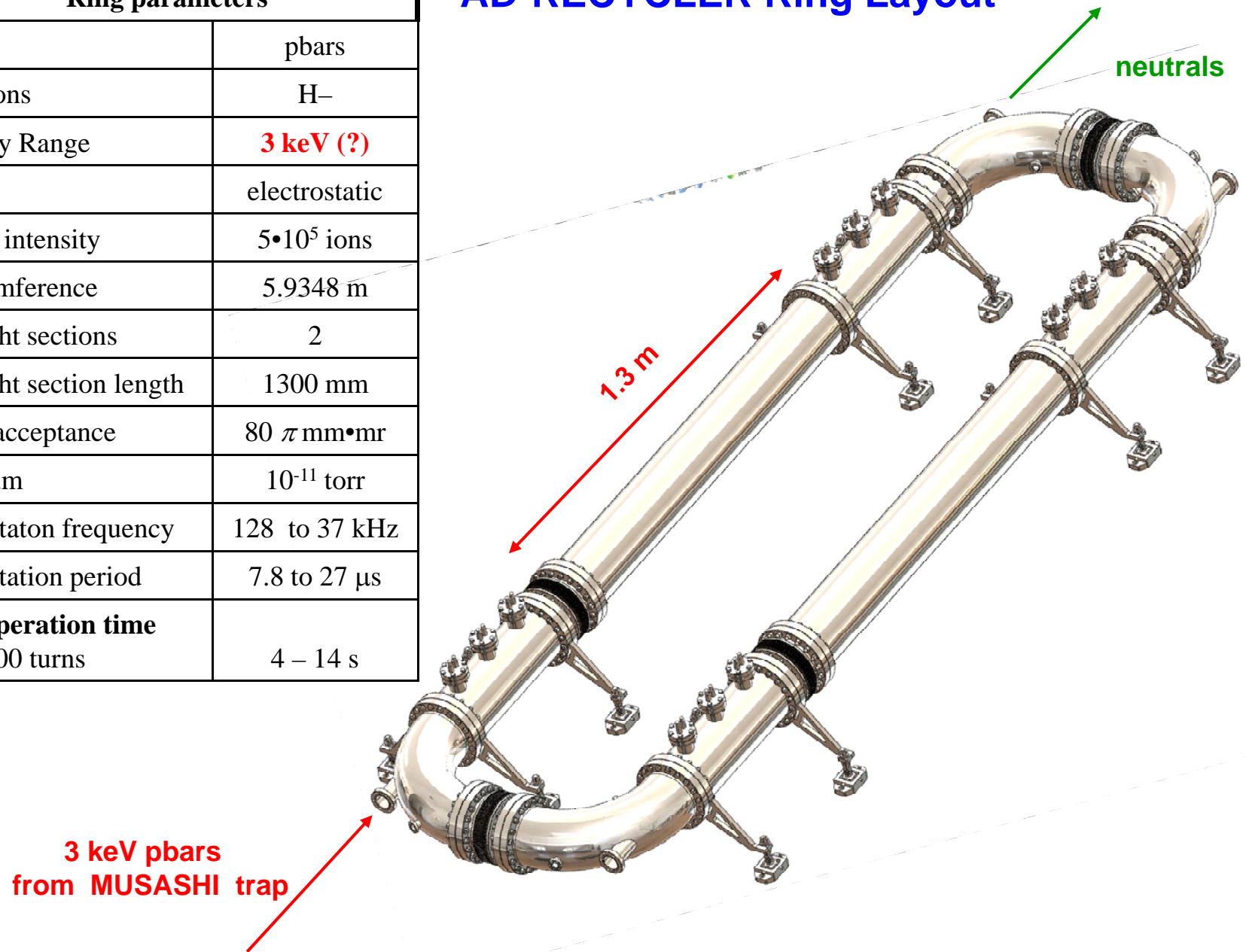

❖ **Lorentz force:**

$$\mathbf{F} = \frac{d\mathbf{p}}{dt} = \frac{d}{dt}(m\mathbf{v}) = q(\mathbf{v} \times \mathbf{B}) \quad (1)$$

❖ **The three components of this force in a cylindrical system  $(r, \Theta, z)$  are well known,**

$$F_\rho = \frac{d}{dt}(m\dot{\rho}) - m\rho\dot{\Theta}^2 = q(\rho\dot{\Theta}B_z - \dot{z}B_\Theta),$$

$$F_\Theta = \frac{1}{\rho} \frac{d}{dt}(m\rho^2\dot{\Theta}) = -q(\dot{\rho}B_z - \dot{z}B_\rho), \quad (2)$$

$$F_z = \frac{d}{dt}(m\dot{z}) = q(\dot{\rho}B_\Theta - \rho\dot{\Theta}B_\rho).$$

FOR REFERENCE ONLY  
DO NOT MEMORIZE

❖ **The simplest solution (apart from  $\underline{v}$  parallel to  $\underline{B}$ ) is a circular motion perpendicular to a uniform field in the  $z$ -direction,**

$$\dot{\Theta} = -\frac{q}{m} B_0 = \Omega_c \quad (3)$$

**This is known as *Cyclotron Motion* and  $\Omega_c$  is the *Cyclotron Frequency*.**

# More on cyclotron motion

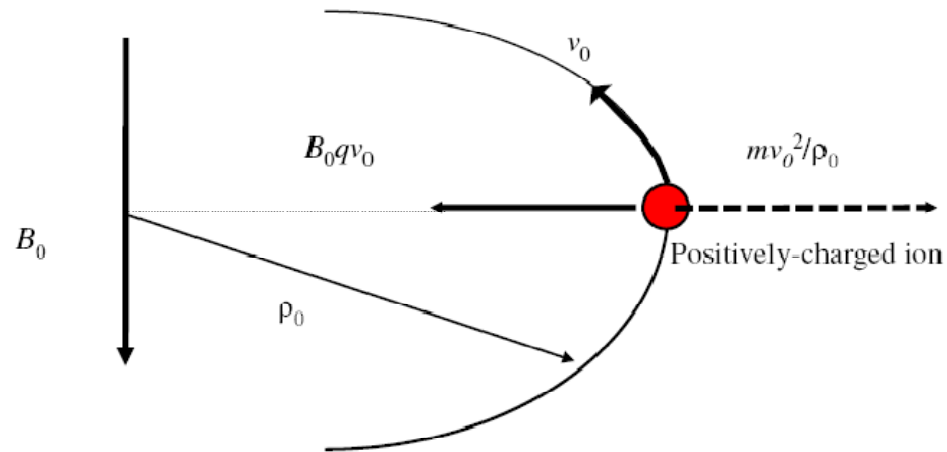

- ❖ Or more simply, equate expressions for the centripetal force:

$$q v_0 B_0 = -\frac{m v_0^2}{\rho_0} \quad (4)$$

- ❖ This leads to a universally-used ‘engineering’ formula, which relates the momentum of the ion to its *Magnetic Rigidity*, or reluctance to be deviated by the magnetic field.

$$|B_0 \rho_0| [\text{Tm}] = \left( \frac{3.3356}{n} \right) A |\bar{p}| [\text{GeV}/c] \quad (5)$$

## ❖ Summary:

- ❖ The 'hard-edge' model is used for almost all lattice calculations.
- ❖ In this model, the central or equilibrium orbit is a stepwise progression of straight sections and circular arcs of cyclotron motion.
- ❖ For a singly-charged particle (5) simplifies to,

$$|B_0 \rho_0| [\text{Tm}] = 3.3356 p [\text{GeV}/c]$$

$$p [\text{MeV}/c] = 300 BR [\text{T}, \text{m}]$$

$$E^2 = W_0^2 + p^2 c^2$$

$$p = m_0 \gamma \beta c$$

$$pc = \beta \gamma W_0 = W_0 + T$$

$$mv^2/R = e/c [v \times B]$$

**Q.1. Please derive these formula**



# *Transverse motion in plane of bending*

- ❖ It is assumed that the deviation from the circular orbit will always be small and the angular velocity can be approximated by  $v_0/\rho$ , so that,

$$F_\rho = m \frac{d^2 \rho}{dt^2} - m \frac{v_0^2}{\rho} = qv_0 B_z$$

Thus, the magnetic deflection is considered as a 'central force' and is equated to the radial acceleration.

## *Transverse motion in plane of bending*

- ❖ Two transformations will be used to introduce the local  $(x, s, z)$  co-ordinate system that follows the equilibrium orbit,

$$\frac{d}{dt} \equiv v_0 \frac{d}{ds}, \quad \rho = \rho_0 + x$$

to give,

$$\frac{d^2 x}{ds^2} - \frac{1}{\rho_0 + x} = \frac{q}{mv_0} B_z$$

- ❖ Next, the charge to mass ratio is re-expressed using (4) as,

$$\frac{q}{m} = \frac{ne}{A\bar{m}} = -\frac{v_0}{B_0 \rho_0}$$

## *Transverse motion in plane of bending*

- ❖ Now expand the field in a Taylor series up to the quadrupole component,

$$B_z = \left\{ B_0 + \left( \frac{\partial B_z}{\partial x} \right)_0 x \dots \right\} = \left\{ B_0 - |B\rho|k x \dots \right\}$$

where

$$k = -\frac{1}{|B\rho|} \left( \frac{\partial B_z}{\partial x} \right)_0 \quad (7)$$

$k$  is the *normalised gradient*. Note that the sign convention chosen introduces a ‘minus’. In other lectures, you will surely see a ‘plus’ sign and a different right-handed co-ordinate system. Welcome to two differences that you will find throughout the literature.

- ❖ Substituting for the field and remembering that  $x \ll \rho$  gives,

$$\frac{d^2 x}{ds^2} + \left( \frac{1}{\rho_0^2} - k \right) x = 0 \quad (8)$$

**Q.2. Please derive this formula**

## Transverse motion in plane of bending

- ❖ Note that the theory is based on a hard-edge model of a *sector dipole* that looks in plan view like,

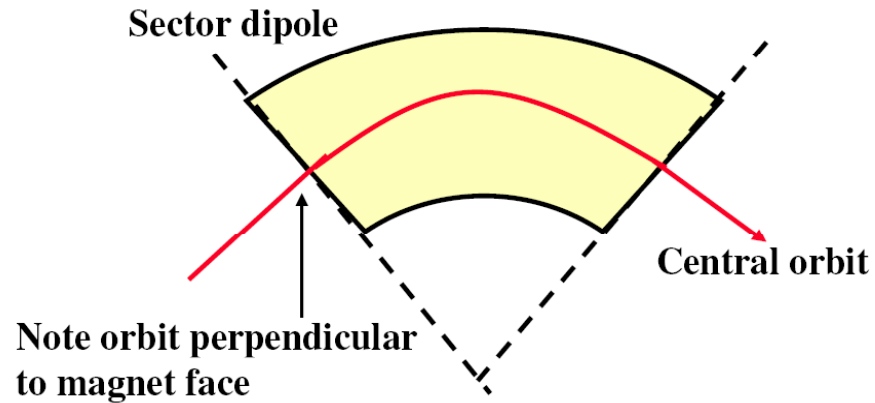

- ❖ However, we often have *rectangular dipoles*. These will require some extra treatment. This is known as *edge focusing*.

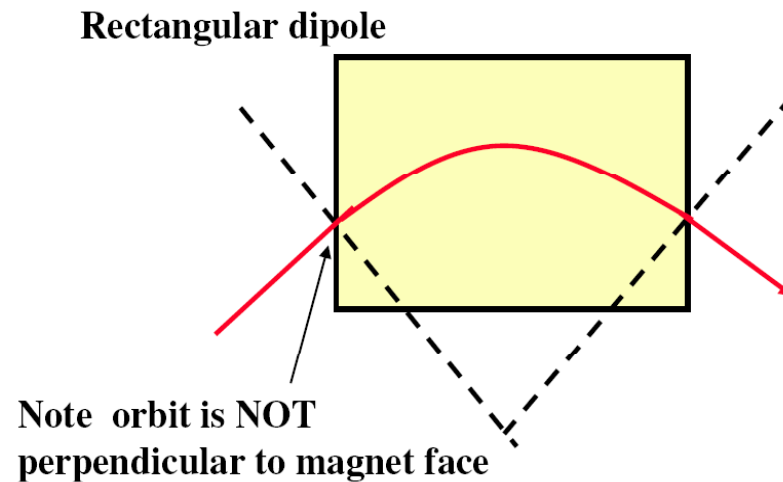

# Transverse motion with a momentum deviation

- ❖ Repeat the earlier derivation with small increments in mass and velocity in evidence, so that,

$$\Delta P/P \neq 0$$

$$F_p = \frac{d}{dt} \left( (m + \Delta m) \frac{d}{dt} \rho \right) - (m + \Delta m) \frac{(v_0 + \Delta v)^2}{\rho} = q(v_0 + \Delta v) B_z$$

- ❖ Now transform time,  $t$ , to distance,  $s$ ,

$$\frac{d}{dt} \equiv (v_0 + \Delta v) \frac{d}{ds}$$

$$\frac{d^2 x}{ds^2} - \frac{1}{\rho_0 + x} = \frac{q}{(m + \Delta m)(v_0 + \Delta v)} B_z$$

- ❖ To first order,

$$\frac{1}{(m + \Delta m)(v_0 + \Delta v)} = \frac{1}{mv_0} \left( 1 - \frac{\Delta m}{m} - \frac{\Delta v}{v_0} \right) = \frac{1}{p_0} \left( 1 - \frac{\Delta p}{p_0} \right)$$

- ❖ So that,

$$\frac{d^2 x}{ds^2} + \left( \frac{1}{\rho_0^2} - k \right) x = \frac{1}{\rho_0} \frac{\Delta p}{p_0} \quad (9)$$

**Q.3. Please derive this formula**

## ***Transverse motion in plane perpendicular to bending***

- ❖ Basically the analysis is repeated, except that the magnetic field has a different form,

$$F_z = \frac{d}{dt} \left( (m + \Delta m) \frac{dz}{dt} \right) = -q(v_0 + \Delta v) B_\rho.$$

$$\frac{d^2 z}{ds^2} = - \frac{q}{(m + \Delta m)(v_0 + \Delta v)} B_\rho.$$

- ❖ Remember that to first order,

$$\frac{1}{(m + \Delta m)(v_0 + \Delta v)} = \frac{1}{mv_0} \left( 1 - \frac{\Delta m}{m} - \frac{\Delta v}{v_0} \right) = \frac{1}{p_0} \left( 1 - \frac{\Delta p}{p_0} \right)$$

which gives,

$$\frac{d^2 z}{ds^2} = \frac{1}{B_0 \rho_0} \left( 1 - \frac{\Delta p}{p_0} \right) B_\rho.$$

## ***Transverse motion in plane perpendicular to bending***

- ❖ Now expand the field and replace  $B_\rho$  by  $B_x$ ,

$$B_\rho \equiv B_x = \left( \frac{\partial B_x}{\partial z} \right)_0 z \quad B_x = 0 \text{ for } z = 0$$

- ❖ Substitution in the motion equation gives,

$$\frac{d^2 z}{ds^2} = -kz \left( 1 - \frac{\Delta p}{p_0} \right).$$

- ❖ But we consider the ' $z \Delta p/p$ ' as second order and discard it to finish with,

$$\frac{d^2 z}{ds^2} + kz = 0$$

**Q.4. Please derive this formula**

- ❖ Note that  $\Delta p/p$  has disappeared so this equation works (to first order) for on- and off-momentum ions. The  $k$  applies to the gradient in combined-function dipoles. For a pure dipole,  $k = 0$  and the dipole acts like a drift space.

❖ Write the equation of motion in a general form,

$$\frac{d^2 y}{ds^2} + K_y(s)y = \frac{1}{\rho_0(s)} \frac{\Delta p}{p_0} \quad (10)$$

$$k = -\frac{1}{|B\rho|} \left( \frac{\partial B_z}{\partial x} \right)_0 \quad (7)$$

where  $y$  can be either  $x$  or  $z$ , and  $K_y(s)$  is the ‘focusing constant’ for the motion. In the plane perpendicular to the bending,  $\rho = \infty$  and the RHS term is removed.

Element	$K_x$	$K_z$
Magnetic combined-function with horizontal bend	$\rho_0^{-2} - k$	$k$
Magnetic combined-function with vertical bend	$-k$	$\rho_0^{-2} + k$
Pure magnetic quadrupole	$-k$	$k$
Pure magnetic horizontal bend	$\rho_0^{-2}$	$0$
Pure magnetic vertical bend	$0$	$\rho_0^{-2}$
Drift space	$0$	$0$

**Q.5. For  $K > 0$  motion is what: stable ? / unstable ?**

- ❖ When  $K > 0$  the motion is stable and sinusoidal.
- ❖ When  $K < 0$  the motion is unstable and hyperbolic.
- ❖ When  $K = 0$  the motion is linear in  $s$ .



# Quadrupole shape

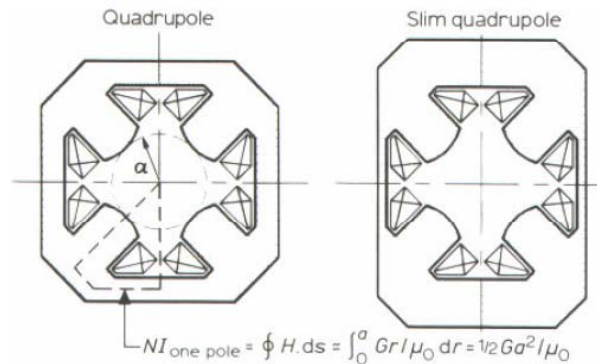
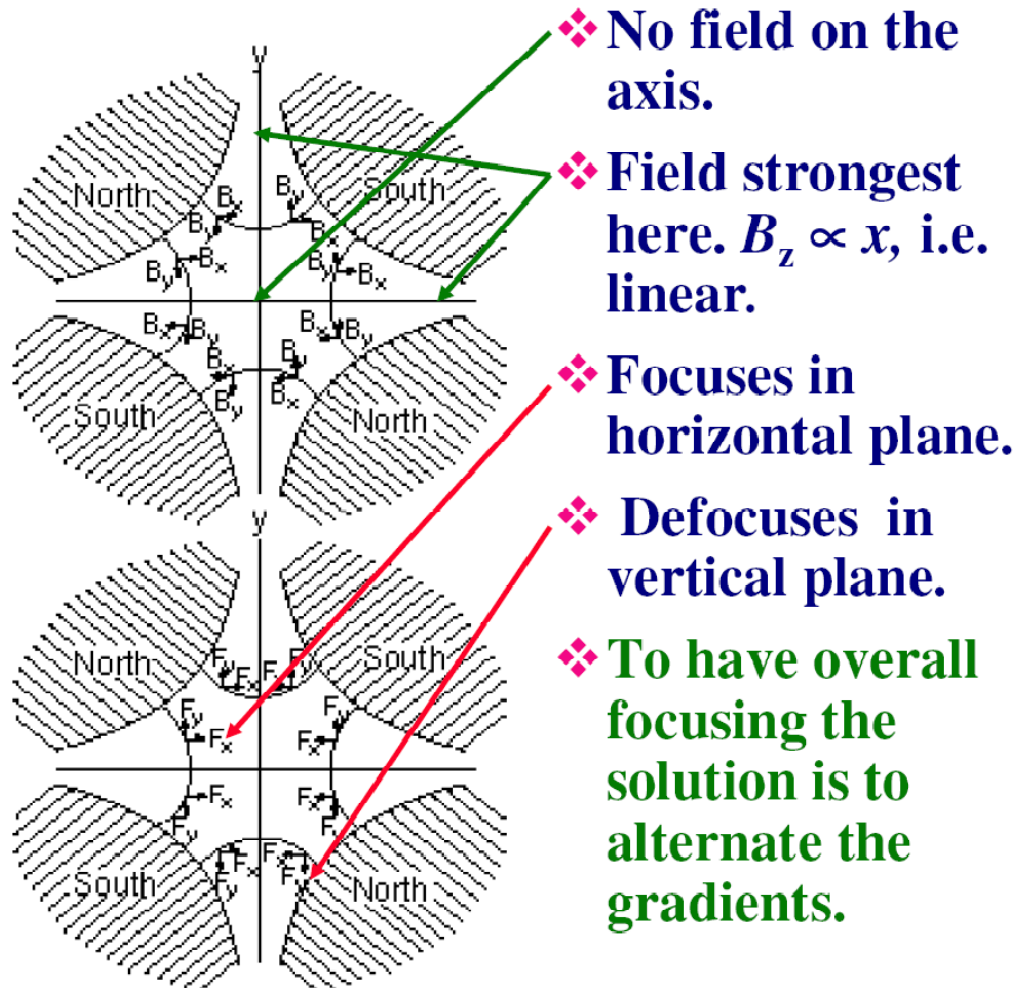

**Q.6. Please draw field and gradient vs radius for Quadrupole**

**Equation  
with periodic  
coefficient**

$$x''(s) + \left\{ \frac{1}{\rho^2(s)} - k(s) \right\} * x(s) = 0$$

## SOLUTION

*Ansatz:*  $x(s) = a_1 \cdot \cos(\omega s) + a_2 \cdot \sin(\omega s)$

*general solution: linear combination of two independent solutions*

$$x'(s) = -a_1 \omega \sin(\omega s) + a_2 \omega \cos(\omega s)$$

$$x''(s) = -a_1 \omega^2 \cos(\omega s) - a_2 \omega^2 \sin(\omega s) = -\omega^2 x(s) \quad \longrightarrow \quad \omega = \sqrt{K}$$

*general solution:*

$$x(s) = a_1 \cos(\sqrt{K}s) + a_2 \sin(\sqrt{K}s)$$

**Stable motion**

$$\sqrt{|K|} > 0$$

$$x(s) = x_0 \cdot \cos(\sqrt{|K|}s) + x'_0 \cdot \frac{1}{\sqrt{|K|}} \sin(\sqrt{|K|}s)$$

$$x'(s) = -x_0 \cdot \sqrt{|K|} \cdot \sin(\sqrt{|K|}s) + x'_0 \cdot \cos(\sqrt{|K|}s)$$

**General solution might be written in MATRIX FORM**

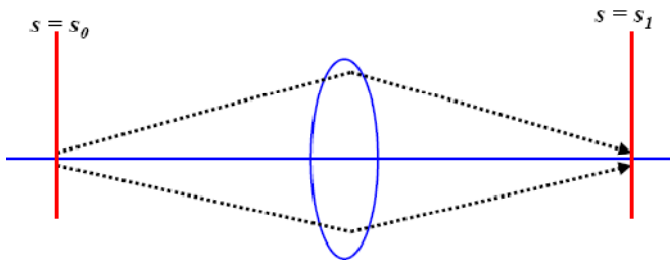

$$\begin{pmatrix} x \\ x' \end{pmatrix}_{s_1} = M_{foc} * \begin{pmatrix} x \\ x' \end{pmatrix}_{s_0}$$

$$M_{foc} = \begin{pmatrix} \cos(\sqrt{|K|}s) & \frac{1}{\sqrt{|K|}} \sin(\sqrt{|K|}s) \\ -\sqrt{|K|} \sin(\sqrt{|K|}s) & \cos(\sqrt{|K|}s) \end{pmatrix}_0$$

**Q. Please write equation for UNSTABLE motion**

*hor. defocusing quadrupole:*

$$x'' - K * x = 0$$

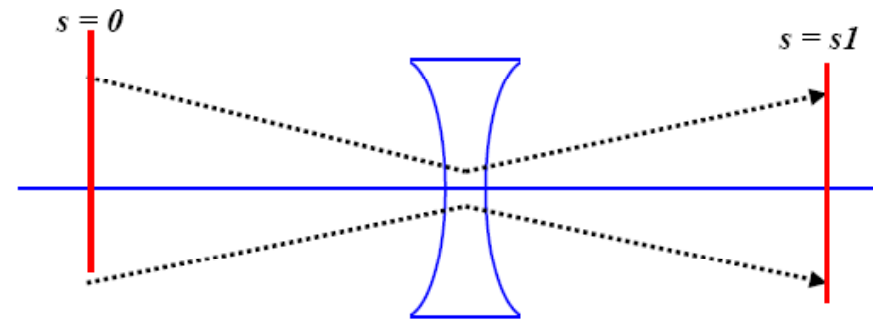

*Remember from school:*

$$f(s) = \cosh(s) \quad , \quad f'(s) = \sinh(s)$$

*Ansatz:*  $x(s) = a_1 \cdot \cosh(\omega s) + a_2 \cdot \sinh(\omega s)$

$$M_{defoc} = \begin{pmatrix} \cosh \sqrt{|K|}l & \frac{1}{\sqrt{|K|}} \sinh \sqrt{|K|}l \\ \sqrt{|K|} \sinh \sqrt{|K|}l & \cosh \sqrt{|K|}l \end{pmatrix}$$

## TRANSFER MATRIX

Coordinate and velocity of ion in point 2 might be expressed as LINEAR combination of Coordinate and velocity of ion in point 1

$$X_2 = m_{11} X_1 + m_{12} X_1'$$

$$X_2' = m_{21} X_1 + m_{22} X_1'$$

**Q- Please derive Matrix of Drift where  $L$  is drift length**

❖ All these results can be written in the general form

$$\begin{pmatrix} y \\ y' \end{pmatrix}_2 = \begin{pmatrix} m_{11} & m_{12} \\ m_{21} & m_{22} \end{pmatrix} \begin{pmatrix} y \\ y' \end{pmatrix}_1 \quad (13)$$

where  $y$  can be  $x$  or  $z$ .

❖ Note that the moduli of all these matrices will be (and must be) unity. This condition conserves phase space and provides a useful check.

$$X_2 = 1 * X_1 + L * X_1'$$

$$X_2' = 0 * X_1 + 1 * X_1'$$

*drift space:*

$$K = 0$$

$$M_{drift} = \begin{pmatrix} 1 & l \\ 0 & 1 \end{pmatrix}$$

## Linear transfer Matrixes

- ❖ The transfer matrix of a focusing element ( $K>0$ ) is:

$$\begin{pmatrix} \cos(\sqrt{|K|}l) & \frac{1}{\sqrt{|K|}} \sin(\sqrt{|K|}l) \\ -\sqrt{|K|} \sin(\sqrt{|K|}l) & \cos(\sqrt{|K|}l) \end{pmatrix} \quad (14)$$

**Q.7. Could somebody derive these matrixes ?**

- ❖ The transfer matrix of a defocusing element ( $K<0$ ) is:

$$\begin{pmatrix} \cosh(\sqrt{|K|}l) & \frac{1}{\sqrt{|K|}} \sinh(\sqrt{|K|}l) \\ \sqrt{|K|} \sinh(\sqrt{|K|}l) & \cosh(\sqrt{|K|}l) \end{pmatrix} \quad (15)$$

- ❖ The transfer matrix of a drift space ( $K=0$ ) is:

$$\begin{pmatrix} 1 & l \\ 0 & 1 \end{pmatrix} \quad (16)$$

*focusing strength of a quadrupole:*

$$k \left[ m^{-2} \right] = \frac{0.2998 \cdot g}{p(\text{GeV} / c)}$$

*focal length of a quadrupole:*

$$f = \frac{1}{k \cdot l_q}$$

*equation of motion:*

$$x'' + Kx = \frac{1}{\rho} \frac{\Delta p}{p}$$

*matrix of a foc. quadrupole:*

$$x_{s2} = M \cdot x_{s1}$$

$$M = \begin{pmatrix} \cos \sqrt{|K|} l & \frac{1}{\sqrt{|K|}} \sin \sqrt{|K|} l \\ -\sqrt{|K|} \sin \sqrt{|K|} l & \cos \sqrt{|K|} l \end{pmatrix}, \quad M = \begin{pmatrix} 1 & 0 \\ \frac{1}{f} & 1 \end{pmatrix}$$



# Calculating trajectories

- ❖ Once the transfer matrices of all the elements in a lattice are known, then transfer through the lattice and to all boundaries between elements can be found by matrix multiplication.

$$\begin{pmatrix} y \\ y' \\ \Delta p / p \end{pmatrix}_n = M_n M_{n-1} \dots M_3 M_2 M_1 \begin{pmatrix} y \\ y' \\ \Delta p / p \end{pmatrix}_1 \quad (17)$$

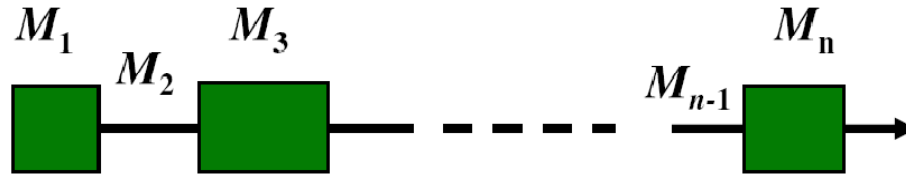

Note that drawings normally have the beam traveling from left to right and the matrix multiplication goes from right to left.

- ❖ This method is universally used for tracking in lattices.
- ❖ We now have 90% of the basic concepts for modeling and tracking.

## *Thin Lens Approximation:*

*matrix of a quadrupole lens*

$$M = \begin{pmatrix} \cos \sqrt{|k|}l & \frac{1}{\sqrt{|k|}} \sin \sqrt{|k|}l \\ -\sqrt{|k|} \sin \sqrt{|k|}l & \cos \sqrt{|k|}l \end{pmatrix}$$

*in many practical cases we have the situation:*

$$f = \frac{1}{kl_q} \gg l_q \quad \dots \text{focal length of the lens is much bigger than the length of the magnet}$$

*limes:  $l \rightarrow 0$  while keeping  $kl = \text{const}$*

$$M_x = \begin{pmatrix} 1 & 0 \\ \frac{1}{f} & 1 \end{pmatrix}$$

$$M_z = \begin{pmatrix} 1 & 0 \\ \frac{-1}{f} & 1 \end{pmatrix}$$

## ***Weak and strong focusing***

- ❖ The analysis given so far is complete, but historically the parameter space was split into '*weak*' and '*strong*' focusing lattices.
- ❖ The conditions for weak focusing are:

$$\frac{1}{p_0^2} > k \quad \text{and} \quad k > 0$$

which means that

$$K_x = \left( \frac{1}{p_0^2} - k \right) > 0 \quad \text{and} \quad K_z = k > 0$$

- ❖ In other words, the motion is stable (sinusoidal) in both planes.

- ❖ The early designers of weak focusing machines did not use the normalised gradient  $k$ . Instead they used a parameter called the *field index* denoted by  $n$ .

$$n = -\frac{\rho_0}{B_0} \left( \frac{\partial B_z}{\partial x} \right)_0$$

- ❖ The minus sign in  $n$  was introduced so that the weak focusing criterion could be expressed as,

$$0 < n < 1$$

- ❖ Originally, the sign convention used for  $n$  was carried over to  $k$  (as used in these lectures), but later it became popular to remove the minus sign from  $k$ , so it is always necessary to check which sign convention is in force.

To link the old and new definitions of weak focusing:

Old definition:  $1 > n > 0$  or  $1 > -\frac{\rho_0}{B_0} \left( \frac{\partial B_z}{\partial x} \right)_0 > 0$

use:  $k = -\frac{1}{(B\rho)_0} \left( \frac{\partial B_z}{\partial x} \right)_0$

to get:  $\frac{1}{p_0^2} > k$  and  $k > 0$

**Q.8. Please draw shape of field in classic cyclotron to provide weak focusing**

***TRANSVERSE MOTION***  
***&***  
***ELECTROSTATIC***  
***ELEMENTS***

- ❖ **There is a fundamental difference between electric and magnetic elements. When traversing a magnetic field the ion's energy is rigorously constant, whereas in an electric field the ion can exchange energy with the field.**
- ❖ **This means that both the mass and velocity of the ion can vary as the ion traverses an electrostatic element. Since the velocity affects the transit time the kick is affected.**
- ❖ **In most of the literature this is elegantly handled by using Lagrangian mechanics, but for pedagogic reasons we will follow an analysis exactly parallel to the analysis for magnetic elements. This shows more clearly where and when the differences occur and what approximations are being made.**
- ❖ **The following will treat the transverse motion and does not apply to elements that are designed to accelerate longitudinally.**

- ❖ **It will be assumed that the angular deviations and transverse excursions in straight elements, i.e. quadrupoles are always small, so that,**
  - ❖ **the transverse electric field is always perpendicular to the particle motion and does not affect the longitudinal velocity and hence the transit time and kick remain unchanged,**
  - ❖ **the transverse excursions are small so that the transverse energy change is negligible.**
- ❖ **Thus, electrostatic quadrupoles behave in essentially the same way as magnetic quadrupoles.**
- ❖ **This leaves the bends, which can have large angles and exhibit new effects.**
- ❖ **It is further assumed that the elements are housed in earthed enclosures, so that there can be no net energy difference between the incoming and outgoing ions.**

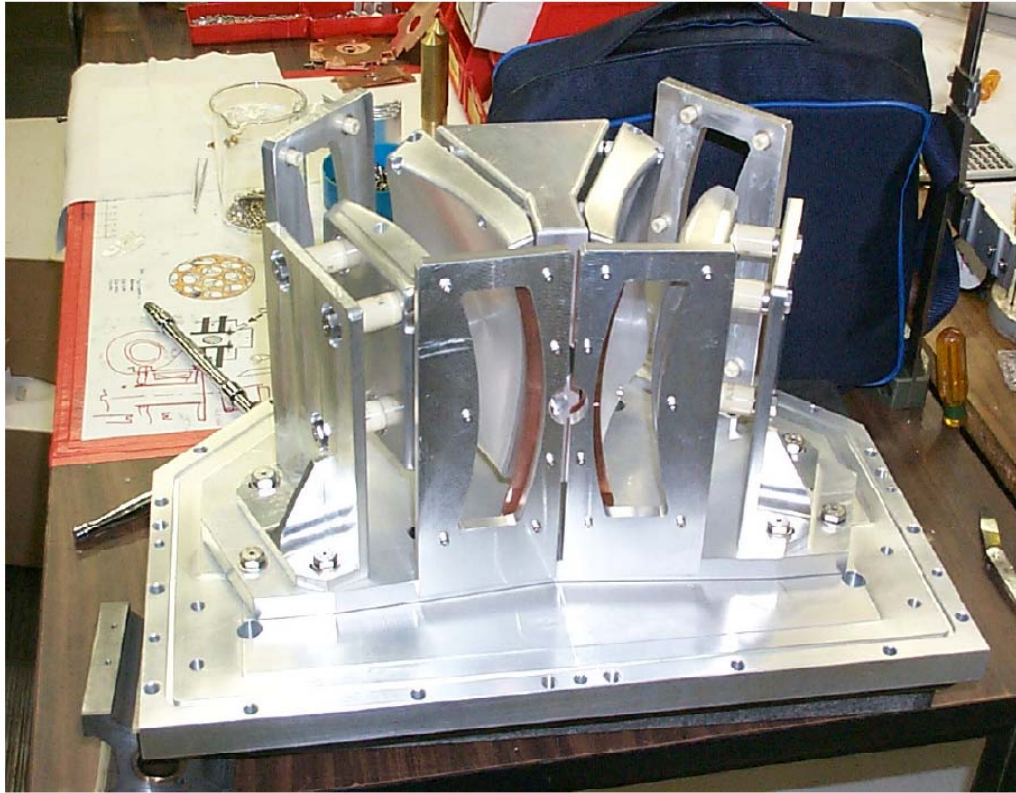

- ❖ **Three-way electrostatic bend: left, right and straight through. Electrodes are spherical (concentric) giving focusing in both planes.**
- ❖ **In general electrodes are:**
  - ❖ **Concentric cylinders (*cylindrical bend*), or**
  - ❖ **Concentric spheres (*spherical bend*), or**
  - ❖ **Concentric toroids (*toroidal bend*).**



- ❖ The force,  $F$ , acting on a charged particle in an electric field is,

$$F = \frac{dp}{dt} = \frac{d}{dt}(mv) = qE \quad (1)$$

- ❖ The three components of this force in a cylindrical system  $(\rho, \Theta, z)$  are well known and are written as,

$$\begin{aligned} F_\rho &= \frac{d}{dt}(m\dot{\rho}) - m\rho\dot{\Theta}^2 = qE_\rho \\ F_\Theta &= \frac{1}{\rho} \frac{d}{dt}(m\rho^2\dot{\Theta}) = qE_\Theta \\ F_z &= \frac{d}{dt}(m\dot{z}) = qE_z \end{aligned} \quad (2)$$

FOR REFERENCE  
DO NOT MEMORIZE

Q.8. Please derive formula

- ❖ The equivalent of cyclotron motion is obtained by launching an ion perpendicular to a radial field, so that  $E_\rho = E_0$  (constant),  $E_\Theta = E_z = 0$ ,  $\rho = \rho_0$  (constant) and  $z = z_0$  (constant), to give,

$$E_0 q = - \frac{mv_0^2}{\rho_0} \quad (3)$$

where  $q = ne$  is the ion's charge and  $m$  its relativistic mass.

# Electrical rigidity

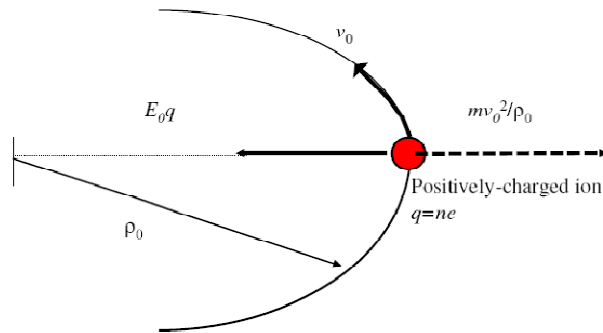

- ❖ Alternatively, the equivalent of cyclotron motion is found simply by equating the expressions for the centripetal force,

$$E_0q = -\frac{mv_0^2}{\rho_0}$$

- ❖ This gives the *electric rigidity*, the equivalent of the *magnetic rigidity*. Re-writing (3) as an 'engineering' formula gives,

$$|E_0\rho_0| [\text{kV}] = \frac{(\gamma+1)}{\gamma} \frac{A}{n} |\bar{T}| [\text{keV}] \quad (4)$$

- ❖ where  $n$  is the charge number of the ion so that  $q = ne$ ,  $A$  is the atomic mass number and  $T$  is the average kinetic energy per nucleon. This relation defines the central orbit in an electrostatic bend just as the magnetic rigidity defines the central orbit in a dipole.

Magnetic rigidity

$$\rho c [\text{MeV}] = 300 BR [\text{T}\cdot\text{m}]$$

$$\rho c = \beta\gamma W_0 = W_0 + T$$

$W_0$  – rest energy

Q.8. Please derive formula

# Electrical rigidity

PROMPT

$$E_0 q = -\frac{mv_0^2}{\rho_0}$$

$$E_0 \rho_0 = -\frac{mv_0^2}{q}$$

$$|E_0 \rho_0| = \frac{mc^2 \beta^2}{q} = \frac{mc^2}{q} \left(1 - \frac{1}{\gamma^2}\right) \quad (\text{A})$$

$$mc^2 = m_0 c^2 + T$$

$$T = m_0 c^2 (\gamma - 1) \quad \text{so that} \quad m_0 c^2 = \frac{T}{(\gamma - 1)}$$

$$mc^2 = \frac{T}{(\gamma - 1)} + T = T \frac{\gamma}{(\gamma - 1)} \quad (\text{B})$$

Substitute (B) into (A)

$$|E_0 \rho_0| = \frac{1}{q} \left(1 - \frac{1}{\gamma^2}\right) T \frac{\gamma}{(\gamma - 1)} = \frac{T}{e} \frac{(\gamma + 1)(\gamma - 1)}{\gamma^2} \frac{\gamma}{(\gamma - 1)}$$

$$|E_0 \rho_0| = \frac{T}{e} \frac{(\gamma + 1)}{\gamma}$$

## ***Transverse motion in an electrostatic bend***

- ❖ Consider directly ions that enter with a momentum deviation,  $\Delta p$  that contains the mass and velocity deviations  $\Delta m$  and  $\Delta v$ . Since the bend is in a screened enclosure, the ion leaves with the same deviations.
- ❖ Inside the device, the ion can exchange energy with the electric field and suffer variable mass and velocity deviations denoted by  $\delta m$  and  $\delta v$ .
- ❖ Re-writing the radial equation from (2) with the deviations in evidence,

$$\frac{d}{dt} \left( (m + \Delta m + \delta m) \frac{d}{dt} \rho \right) - (m + \Delta m + \delta m) \frac{(v_0 + \Delta v + \delta v)^2}{\rho} = qE_\rho$$

- ❖ This only differs from the magnetic case in that the force term is changed and the mass and velocity deviations are separated into constant and variable parts.
- ❖ As always, we look for approximations and first we neglect the effect of the variable mass deviation  $\delta m$  inside the differential, so that,

$$(m + \Delta m + \delta m) \frac{d^2}{dt^2} \rho - (m + \Delta m + \delta m) \frac{(v_0 + \Delta v + \delta v)^2}{\rho} = qE_\rho$$

## ***Transverse motion in an electrostatic bend***

- ❖ As usual we transform the independent variable from time,  $t$ , to distance,  $s$ , and introduce the local coordinate  $x$  for the excursion,

$$\frac{d}{dt} \equiv (v_0 + \Delta v + \delta v) \frac{d}{ds}$$

$$\rho = \rho_0 + x$$

which gives,

$$\frac{d^2 x}{ds^2} - \frac{1}{(\rho_0 + x)} = qE_p \frac{1}{(m + \Delta m + \delta m)(v_0 + \Delta v + \delta v)^2}$$

- ❖ Expanding the RHS and truncating to 1st order gives,

$$\frac{d^2 x}{ds^2} - \frac{1}{(\rho_0 + x)} = \frac{qE_p}{mv_0^2} \left( 1 - \underbrace{\left[ \frac{\Delta m}{m} + 2 \frac{\Delta v}{v_0} \right]}_{\substack{\text{Constant} \\ \text{increments} \\ \text{defined by} \\ \text{incoming beam.}}} - \underbrace{\left[ \frac{\delta m}{m} + 2 \frac{\delta v}{v_0} \right]}_{\substack{\text{Variable increments} \\ \text{depending on the} \\ \text{excursion } x \text{ inside the} \\ \text{apparatus.}}} \right)$$

## Transverse motion in an electrostatic bend

Cylindrical  
Electro  
Static  
Deflector  
(ESD)

- It is now necessary to evaluate the field between two cylindrical plates biased at  $\pm V/2$  with respect to the screening enclosure. Neglecting any fringe fields, the equi-potential surfaces will be concentric with the electrode surfaces, so that,

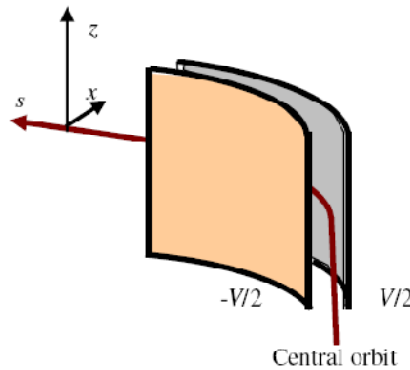

$$E_0 \ell = E_\rho (\ell + \Delta \ell)$$

$$\theta = \frac{\ell}{\rho_0} = \frac{(\ell + \Delta \ell)}{(\rho_0 + x)}$$

$$E_0 \rho_0 = E_\rho (\rho_0 + x)$$

$$E_x \equiv E_\rho = E_0 \frac{\rho_0}{(\rho_0 + x)} \quad (6)$$

- Substituting for the field from (6) and  $q/m$  from (3) gives,

$$\frac{d^2 x}{ds^2} - \frac{1}{(\rho_0 + x)} = -\frac{1}{(\rho_0 + x)} \left( 1 - \left[ \frac{\Delta m}{m} + 2 \frac{\Delta v}{v_0} \right] - \left[ \frac{\delta m}{m} + 2 \frac{\delta v}{v_0} \right] \right) \quad (7)$$

# Linearized equation of transverse motion in electrostatic deflecting elements

- ❖ The combination of (7), (8) and (9) finally gives the radial motion equation,

$$\frac{d^2x}{ds^2} + \frac{1}{\rho_0^2} (2 - \beta^2)x = \frac{1}{\rho_0} \frac{\Delta p}{p} (2 - \beta^2) \quad (10)$$

**DIPOLE Magnet  
Plane of bend**

$$\frac{d^2x}{ds^2} + \left( \frac{1}{\rho_0^2} - k \right)x = \frac{1}{\rho_0} \frac{\Delta p}{p_0}$$

- ❖ *This only differs from the equivalent magnetic equation for a pure dipole by the factor  $(2 - \beta^2)$ . So apart from this additional term, the same general solutions can be used to construct the transfer matrices.*
- ❖ At relativistic energies (as  $\beta \rightarrow 1$ ), the difference between the motion equations disappears.
- ❖ Comparing magnetic and electric bends shows that:
  - At low energies, the  $(1 + \gamma)$  term in the numerator of the rigidity improves the efficiency of electrostatic bends. The convenience of being able to shape the field with simple mechanical surfaces, calculate the field from simple mechanical dimensions, the low power consumption and the absence of hysteresis and heating leads to these devices being widely used.

# Matrices for on-momentum ions

- ❖ The transfer matrix of a focusing element ( $K > 0$ ) is:

$$\begin{pmatrix} \cos(\sqrt{|K|}\ell) & \frac{1}{\sqrt{|K|}} \sin(\sqrt{|K|}\ell) \\ -\sqrt{|K|} \sin(\sqrt{|K|}\ell) & \cos(\sqrt{|K|}\ell) \end{pmatrix} \quad (11)$$

SAME TRANSFER  
MATRIXES AS FOR  
MAGNET !

- ❖ The transfer matrix of a defocusing element ( $K < 0$ ) is:

$$\begin{pmatrix} \cosh(\sqrt{|K|}\ell) & \frac{1}{\sqrt{|K|}} \sinh(\sqrt{|K|}\ell) \\ \sqrt{|K|} \sinh(\sqrt{|K|}\ell) & \cosh(\sqrt{|K|}\ell) \end{pmatrix} \quad (12)$$

- ❖ The transfer matrix of a drift space ( $K = 0$ ) is:

$$\begin{pmatrix} 1 & \ell \\ 0 & 1 \end{pmatrix} \quad (13)$$

where,

$$K_x = \frac{1}{\rho_0^2} (2 - \beta^2), \quad K_z = 0 \quad (14)$$

Cylindrical ESD



## Arbitrary shape of ESD

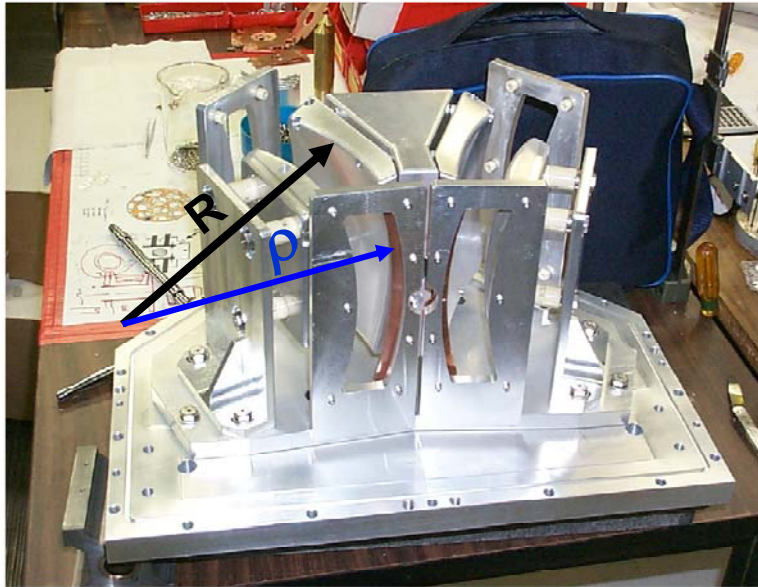

Electric field INDEX

$$n_E = - (R/E_R) dE_R/dR \cong 1 + R/\rho$$

$$K_x = (3 - n_E - \beta^2) / R^2$$

$$K_y = (n_E - 1) / R^2$$

ELDEFL focusing  
condition

$$1 < n_E < 3$$

sector magnet

$$0 < n_M < 1$$

- ❖ Three-way electrostatic bend: left, right and straight through. Electrodes are spherical (concentric) giving focusing in both planes.
- ❖ In general electrodes are:
  - ❖ Concentric cylinders (*cylindrical bend*), or
  - ❖ Concentric spheres (*spherical bend*), or
  - ❖ Concentric toroids (*toroidal bend*).

ESD type	cylindrical	spherical	Hyperbolic	Anti-spherical
$\rho$	$\rho = \infty$	$\rho = R$	$\rho = -R/2$	$\rho = -R$
$n_E$	1	2	-1	0
$k_X$	$2/R^2$	$1/R^2$	$4/R^2$	$3/R^2$
$k_Y$	0	$1/R^2$	$-2/R^2$	$-1/R^2$
	focus in X drift in Y	Equal focus $f_x = f_y$	Focus X Defocus Y	Focus X Defocus Y

Q ?. Can You derive coefficients for TOROIDAL ESD ?

## Equation of transverse motion in ESD with CYLINDRICAL shape electrodes

second order approximation

$$x'' + \frac{2}{R_{eq}^2} x - \frac{1}{R_{eq}^3} x^2 = 0$$

$$y'' = 0$$

Linear approximation

**Q. Please write LINEAR equation  
of transverse motion in ESD-CYL**

**IN the Linear approximation Cylindrical deflector  
focuses beam in radial direction with DOUBLE  
strength wrt Spherical electrode and it is DRIFT  
In axial direction**

## Equation of transverse motion in ESD with SPHERICAL shape electrodes

Second order approximation

$$x'' + \frac{1}{R_{eq}^2} x - \frac{1}{R_{eq}^3} x^2 - \frac{3}{2 \cdot R_{eq}^3} y^2 = 0$$

$$y'' + \frac{1}{R_{eq}^2} y - \frac{3}{R_{eq}^3} xy = 0$$

Linear approximation

$$x'' + \frac{1}{R_{eq}^2} x = 0$$

$$y'' + \frac{1}{R_{eq}^2} y = 0$$

**In the linear approximation spherical deflector  
focuses beam in both directions  
with the same force**

## Example of ESD with plates of SPHERICAL Shape

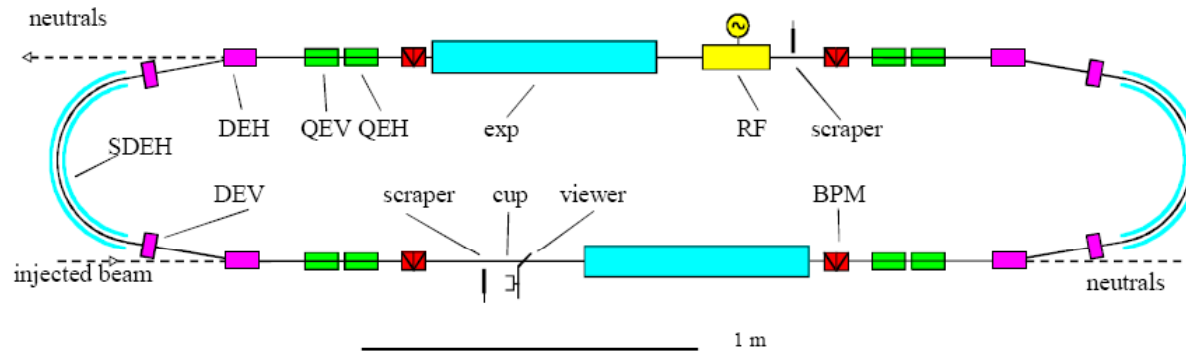

Figure 1: Layout of the ELISA storage ring. The abbreviations are explained in the text.



Figure 3: Picture of the ELISA storage ring.

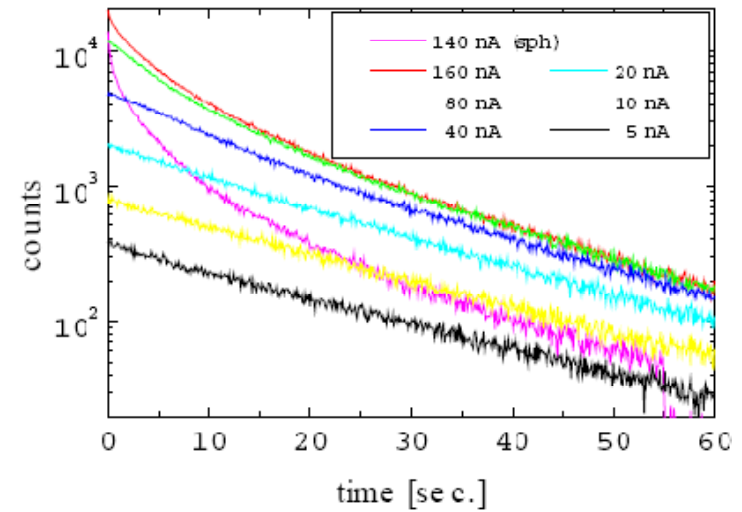

Figure 4: Decays of stored  $O^-$  beams at 22 keV.

# OPERA / MAD-X simulations of ELISA Ring with ESD plates of SPHERICAL and CYLINDRICAL Shape (O.Gorda, A.Papash)

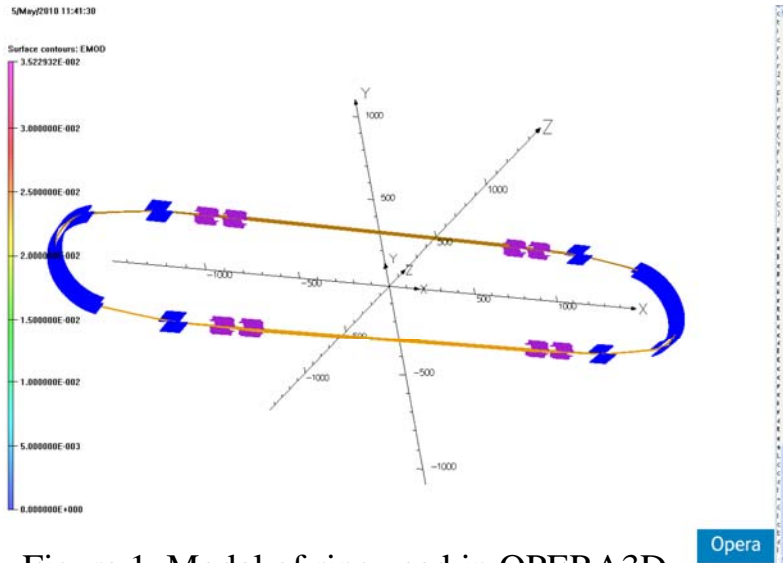

Figure 1. Model of ring used in OPERA3D. Dimensions and distances between elements similar to original ELISA design [2].

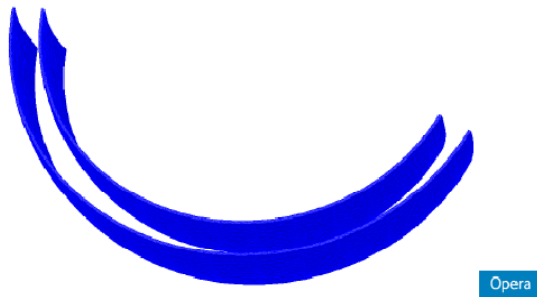

Figure 2: Model of ESD-SPH deflector used in field simulations with OPERA.

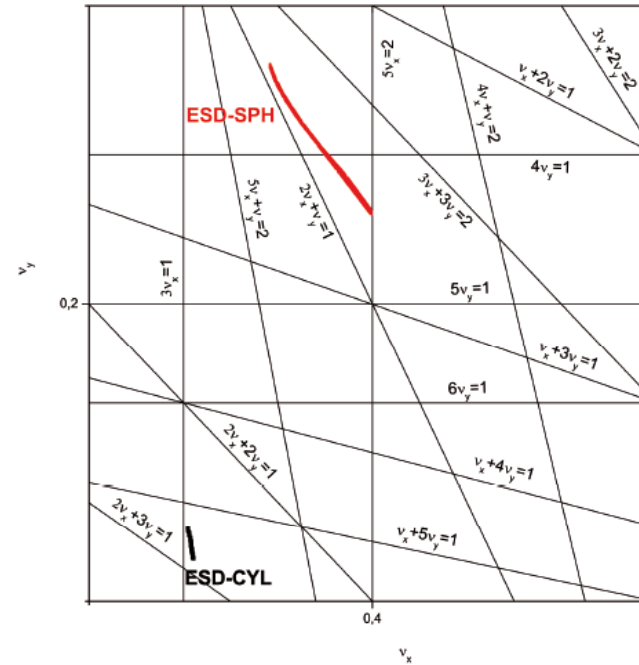

Figure 15: Amplitude dependent tune shift in the ELISA for the ESD-SPH and ESD-CYL mode.

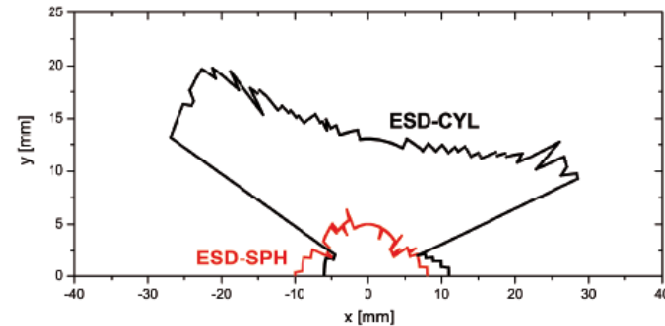
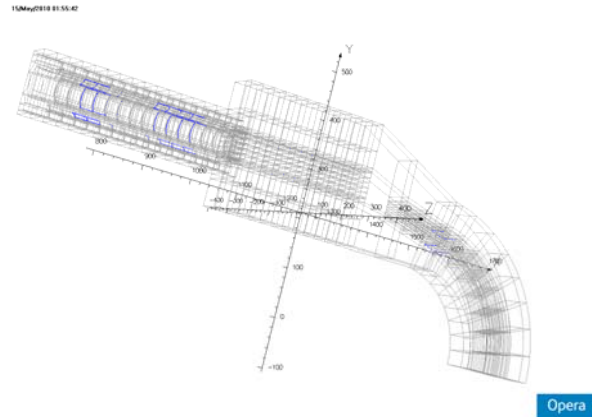
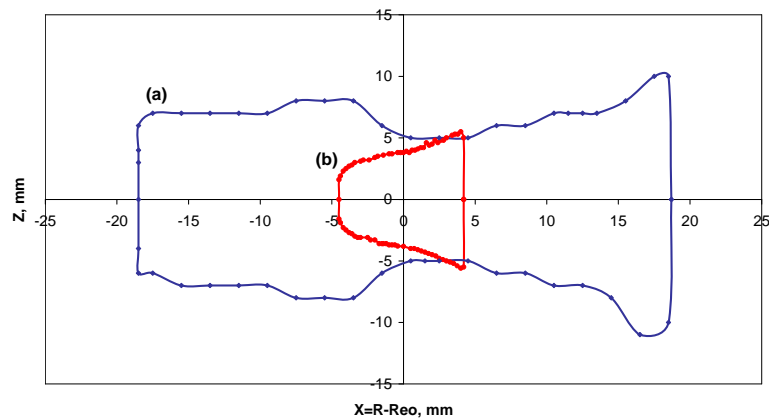

Figure 16: Dynamic aperture of the ELISA storage ring.

## ELISA – OPERA-TOSCA 3D simulations



**Figure 3.** Ring geometry was split in multiple sectors and parts to provide correct distribution of electric field. Shown is region with quads, 10° parallel plate deflector and 154° cylindrical electrodes



**Figure 4.** Dynamic aperture of ring with 160° electrostatic deflectors of cylindrical shape. OPERA simulations:  
 a) middle of long straight section, azimuth  $\theta=0^\circ$ ,  
 b) middle of ESD-160, azimuth  $\theta=90^\circ$ .

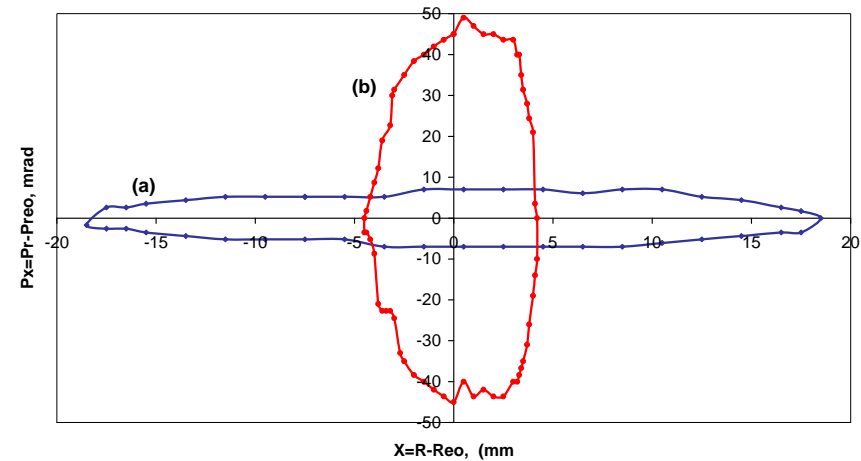

**Figure 5** Radial acceptance of ring with 160° ESD\_CYL.  
 (a) middle of long straight section, azimuth  $\theta=0^\circ$ ,  
 (b) middle of ESD-160, azimuth  $\theta=90^\circ$ .

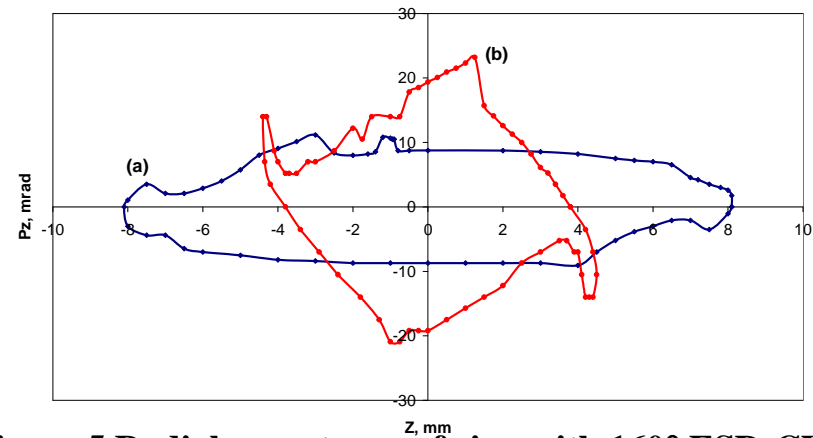

**Figure 5** Radial acceptance of ring with 160° ESD-CYL  
 (a) middle of long straight section, azimuth  $\theta=0^\circ$ ,  
 (b) middle of ESD-160, azimuth  $\theta=90^\circ$ .

## Solutions of the motion equation including momentum

❖ As for the magnetic case,

$$\begin{pmatrix} y \\ y' \\ (\Delta p / p)_2 \end{pmatrix} = \begin{pmatrix} m_{11} & m_{12} & m_{13} \\ m_{21} & m_{22} & m_{23} \\ 0 & 0 & 1 \end{pmatrix} \begin{pmatrix} y \\ y' \\ (\Delta p / p)_1 \end{pmatrix} \quad (15)$$

❖ The terms  $m_{11}$ ,  $m_{12}$ ,  $m_{21}$  and  $m_{22}$  have the form from the earlier slide. New terms have the form,

For  $K > 0$  :

$$\begin{aligned} m_{13} &= \pm(2 - \beta^2) \frac{1}{\rho} \frac{1}{|K|} \left[ 1 - \cos(\sqrt{|K|}\ell) \right] \\ m_{23} &= \pm(2 - \beta^2) \frac{1}{\rho} \frac{1}{\sqrt{|K|}} \sin(\sqrt{|K|}\ell) \end{aligned} \quad (16)$$

For  $K < 0$ :

$$\begin{aligned} m_{13} &= \pm(2 - \beta^2) \frac{1}{\rho} \frac{1}{|K|} \left[ \cosh(\sqrt{|K|}\ell) - 1 \right] \\ m_{23} &= \pm(2 - \beta^2) \frac{1}{\rho} \frac{1}{\sqrt{|K|}} \sinh(\sqrt{|K|}\ell) \end{aligned} \quad (17)$$

[Upper sign for horizontal and lower sign for vertical bending.  $K$  values for cylindrical, spherical and toroidal electrodes are in the Formula Book.]

# Transverse motion in an electrostatic quadrupole

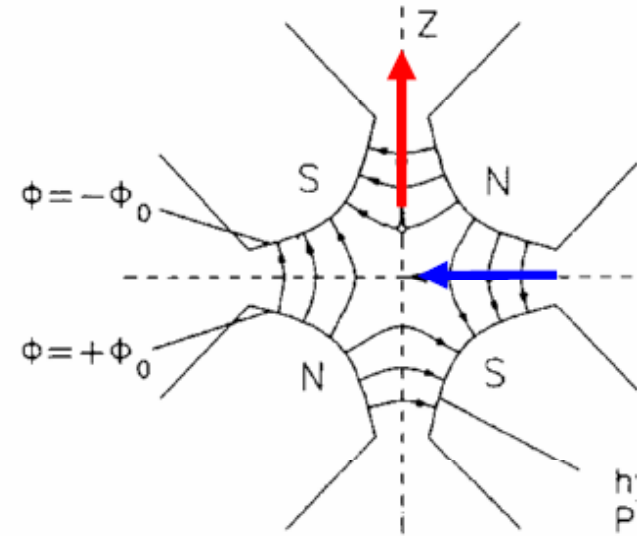
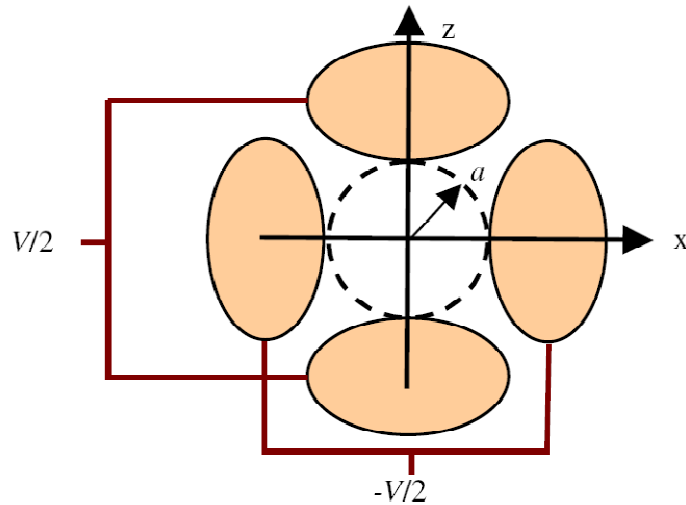

- ❖ Invoking the ‘small-angle’ approximation gives,

$$mv^2 \frac{d^2x}{ds^2} = qE_x$$

$$mv^2 \frac{d^2z}{ds^2} = qE_z$$

[Basically we are following the derivation in Lecture 2]

- ❖ The field components  $E_x$  and  $E_z$  are derived from the potential,

$$\Phi = -\frac{V}{2a^2} (x^2 - z^2) \quad (18)$$

## ***Transverse motion in an electrostatic quadrupole***

❖ The field components are:

$$E_x = -\frac{\partial\Phi}{\partial x} = \frac{V}{a^2}x$$

$$E_z = -\frac{\partial\Phi}{\partial z} = \frac{V}{a^2}z$$

❖ After some substitutions:

$$\frac{d^2x}{ds^2} - \frac{Vq}{a^2mv^2}x = 0$$

$$\frac{d^2z}{ds^2} + \frac{Vq}{a^2mv^2}z = 0$$

❖ The main difference between magnetic and electrostatic quadrupoles is the way in which the  $K$ -factor is expressed:

❖ For electrostatic lenses, we use the voltage across the electrodes because the potential is well defined and a simple calculation can lead to an accurate knowledge of the field.

❖ Whereas for magnets, the corresponding pole tip field is difficult to measure and the current in the coil is related in a non-linear manner to this field. For these reasons, the gradient on the axis is preferred.

where,

$$K_{\begin{matrix} x \\ z \end{matrix}} = \frac{Vq}{a^2mv^2} = \mp \frac{1}{|E_0\rho_0|} \frac{V}{a^2} \quad (20)$$

and the matrices (11) and (12) also apply.



# Straight parallel-plate deflectors

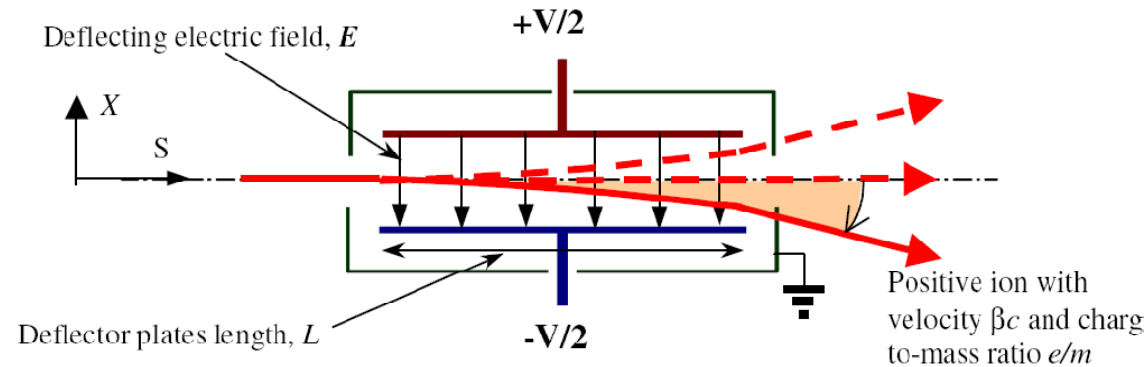

- ❖ Straight parallel-plate deflectors are frequently used for switching.
- ❖ Although they look simple, the detailed analysis is in fact more complicated.
- ❖ First the central orbit is not circular. It is parabolic and that is already an approximation.

$$X_{\text{C.O.}} = -\frac{S^2}{2\rho_0}$$

where  $X$  and  $S$  are survey coordinates not local beam coordinates.

- ❖ The vertical motion is treated as if it were a drift space and the horizontal motion can be approximated as,

$$x = x_0 + x'_0 s + \left[ \frac{\Delta p}{p} (2 - \beta^2) - 1 \right] \frac{s^2}{2\rho_0}$$

- ❖ The electrostatic devices in this lecture are mathematically valid for all energies. However, the lecture is more appropriate for energies above a few MeV.
- ❖ In the present course, you will also come across much lower energies, for example for electron guns.
- ❖ At lower energies (i.e. non-relativistic), it is more usual to use a cylindrical co-ordinate system and to include energy changes (which will be proportionally large) into the equation of motion in a more basic way. Cylindrically symmetric lenses such as the *Einzel* electrostatic lens and the *Glaser* magnetic solenoid lens are more frequently used than quadrupoles in this part of the parameter space.

## Summary

- ❖ We have seen how the transverse motion in an electrostatic bend is affected by energy being exchanged with the bending field.
- ❖ The resultant equations for the bend are basically the same as those of the magnetic case with an additional multiplier  $(2-\beta^2)$ .
- ❖ The case of the quadrupole was treated according to the 'small angle' approximation. This neglects the energy exchanges with the field and the basic physics is then identical.
- ❖ We have also seen that to define the strength of an electrostatic lens, it is customary to refer to the voltage on the electrodes and the radius of the inscribed circle.
- ❖ The equations presented are entirely consistent with the matrix approach used in accelerator theory.
- ❖ A large part of electrostatic lens theory that applies to low energies and uses cylindrically symmetric Einzel and Glaser lens has been omitted.

# ***TWISS FUNCTIONS***

## **Principle of STRONG Focusing**

### **PERIODIC STRUCTURE**

**Ring Lattice consists of N equal cells.  
Each Cell consists of Focusing / defocusing  
elements and bends  
(magnetic or electrostatic...)**

**Focusing - defocusing elements alternate**

**Q. What is the difference of Strong focusing  
from Weak focusing ?**

**Weak focusing must provide focusing  
in both direction simultaneously**

**While strong focusing -**

**it is alternating of focusing /defocusing elements**

### 3.) The Beta Function

$$\frac{d^2 y}{ds^2} + K_y(s)y = 0$$

Hill equation  
Motion with PERIODIC  
FORCE  
 $KY(s+L) = KY(s)$

General solution of Hill's equation:

$$(i) \quad x(s) = \sqrt{\varepsilon} \sqrt{\beta(s)} \cdot \cos(\psi(s) + \phi)$$

$\varepsilon, \Phi =$  integration *constants* determined by initial conditions

$\beta(s)$  *periodic function* given by *focusing properties* of the lattice  $\leftrightarrow$  quadrupoles

$$\beta(s+L) = \beta(s)$$

Inserting (i) into the equation of motion ...

$$\psi(s) = \int_0^s \frac{ds}{\beta(s)}$$

$\Psi(s) =$  „phase advance“ of the oscillation between point „0“ and „s“ in the lattice.

For one complete revolution: number of oscillations per turn „Tune“

$$Q_y = \frac{1}{2\pi} \oint \frac{ds}{\beta(s)}$$

$$Q_y = \frac{\mu_{y,1\text{Turn}}}{2\pi} = \frac{1}{2\pi} \oint_{\text{Circ.}} \frac{1}{\beta_y(\sigma)} d\sigma$$

## *Beam Emittance and Phase Space Ellipse*

general solution of Hill equation

$$\left\{ \begin{array}{l} (1) \quad x(s) = \sqrt{\varepsilon} * \sqrt{\beta(s)} * \cos(\psi(s) + \phi) \\ (2) \quad x'(s) = -\frac{\sqrt{\varepsilon}}{\sqrt{\beta(s)}} * \{ \alpha(s) * \cos(\psi(s) + \phi) + \sin(\psi(s) + \phi) \} \end{array} \right.$$

from (1) we get

$$\cos(\psi(s) + \phi) = \frac{x(s)}{\sqrt{\varepsilon} * \sqrt{\beta(s)}}$$

$$\alpha(s) = \frac{-1}{2} \beta'(s)$$

$$\gamma(s) = \frac{1 + \alpha(s)^2}{\beta(s)}$$

Insert into (2) and solve for  $\varepsilon$

$$\varepsilon = \gamma(s) * x^2(s) + 2\alpha(s)x(s)x'(s) + \beta(s)x'(s)^2$$

- \*  $\varepsilon$  is a *constant of the motion* ... it is independent of „s“
- \* parametric representation of an *ellipse in the  $x x'$  space*
- \* shape and orientation of ellipse are given by  $\alpha, \beta, \gamma$

## 4.) Emittance: The Phase Space Ellipse

particel trajectory:  $x(s) = \sqrt{\varepsilon} \sqrt{\beta(s)} \cos\{\psi(s) + \phi\}$

max. Amplitude:  $\hat{x}(s) = \sqrt{\varepsilon\beta}$   $\longrightarrow$   $x'$  at that position ...?

... put  $\hat{x}(s)$  into  $\varepsilon = \gamma(s) * x^2(s) + 2\alpha(s)x(s)x'(s) + \beta(s)x'(s)^2$  and solve for  $x'$

$$\varepsilon = \gamma \cdot \varepsilon\beta + 2\alpha\sqrt{\varepsilon\beta} \cdot x' + \beta x'^2$$

$\longrightarrow$   $x' = -\alpha \cdot \sqrt{\varepsilon / \beta}$

\* A high  $\beta$ -function means a large beam size and a small beam divergence. !  
 ... et vice versa !!!

\* In the middle of a quadrupole  $\beta$  is maximum,  
 $\alpha = \text{zero}$  }  $x' = 0$  ... and the ellipse is flat



## 0.) Remember:

### Beam Emittance and Phase Space Ellipse:

equation of motion:  $x''(s) - k(s) * x(s) = 0$

general solution of Hills equation:  $x(s) = \sqrt{\epsilon} * \sqrt{\beta(s)} * \cos(\psi(s) + \varphi)$

beam size:  $\sigma - \sqrt{\epsilon\beta} \approx \text{"mm"}$

$$\epsilon = \gamma(s) * x^2(s) + 2\alpha(s)x(s)x'(s) + \beta(s)x'(s)^2$$

$$\alpha(s) = -\frac{1}{2} \beta'(s)$$

$$\gamma(s) = \frac{1 + \alpha(s)^2}{\beta(s)}$$

- \*  $\epsilon$  is a *constant of the motion* ... it is independent of „s“
- \* parametric representation of an *ellipse in the  $x x'$  space*
- \* shape and orientation of ellipse are given by  $\alpha, \beta, \gamma$

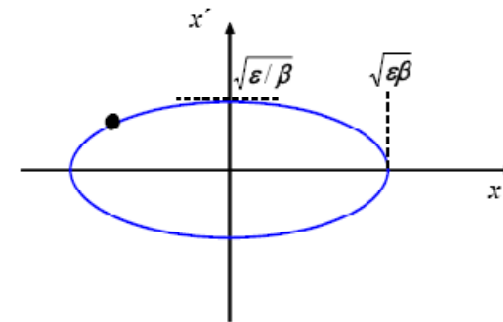
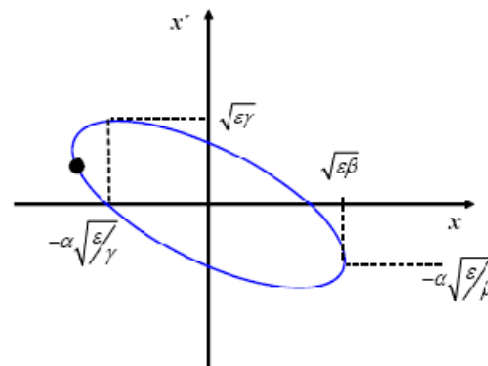
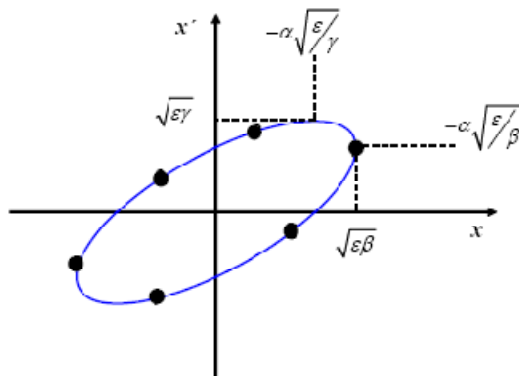

# Geometry of the phase-space ellipse

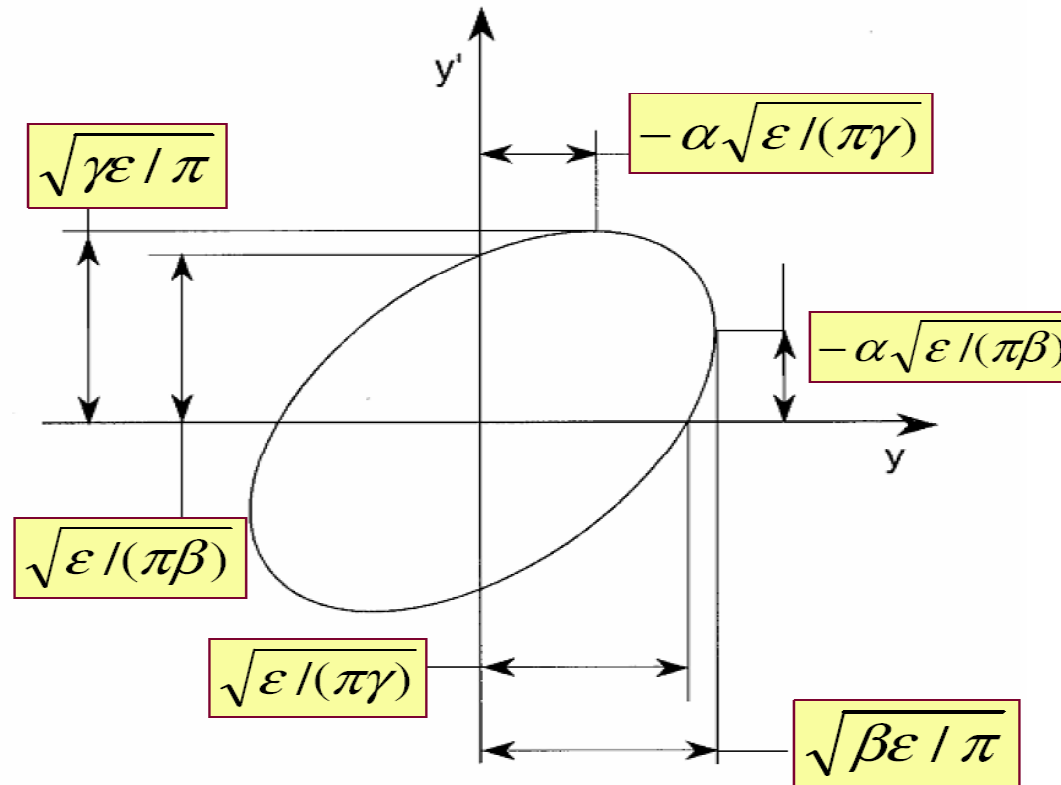

$$\text{Area} = \epsilon = \pi \left( \gamma y^2 + 2\alpha y y' + \beta y'^2 \right)$$

Practical emittance definition that defines ellipse:

$$\epsilon = \pi \left( \gamma_y y_{1-\sigma}^2 + 2\alpha_y y_{1-\sigma} y'_{1-\sigma} + \beta_y y'^2_{1-\sigma} \right)$$

# 1.) Liouville during Acceleration

$$\varepsilon = \gamma(s) * x^2(s) + 2\alpha(s)x(s)x'(s) + \beta(s)x'(s)^2$$

*Beam Emittance* corresponds to the area covered in the  $x, x'$  Phase Space Ellipse

*Liouville:* Area in phase space is constant.

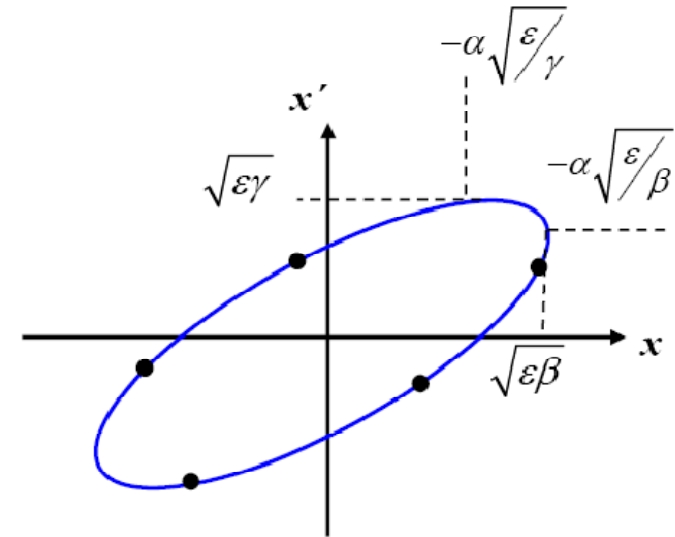

**But:  $\varepsilon \neq \text{const}!$**

*Classical Mechanics:*

*phase space* = diagram of the two canonical variables  
position & momentum

$x$                        $p_x$

$$p_j = \frac{\partial L}{\partial \dot{q}_j} \quad ; \quad L = T - V = \text{kin. Energy} - \text{pot. Energy}$$

According to Hamiltonian mechanics:  
 phase space diagram relates the variables  $q$  and  $p$

$$q = \text{position} = x$$

$$p = \text{momentum} = \gamma m v = m c \gamma \beta_x$$

$$\gamma = \frac{1}{\sqrt{1 - \frac{v^2}{c^2}}} \quad ; \quad \beta_x = \frac{\dot{x}}{c}$$

Liouville's Theorem:  $\int p dq = \text{const}$

for convenience (i.e. *because we are lazy bones*) we use in accelerator theory:

$$x' = \frac{dx}{ds} = \frac{dx}{dt} \frac{dt}{ds} = \frac{\beta_x}{\beta} \quad \text{where } \beta_x = v_x / c$$

$$\int p dq = m c \int \gamma \beta_x dx$$

$$\int p dq = m c \gamma \beta \underbrace{\int x' dx}_{\varepsilon}$$

$$\Rightarrow \varepsilon = \int x' dx \propto \frac{1}{\beta \gamma}$$

*the beam emittance  
 shrinks during  
 acceleration  $\varepsilon \sim 1 / \gamma$*

### 3.) Dispersion: trajectories for $\Delta p / p \neq 0$

**Question:** do you remember 1st session, page 15 ? ... sure you do

Force acting on the particle

$$F = m \frac{d^2}{dt^2} (x + \rho) - \frac{mv^2}{x + \rho} = -e B_z v$$

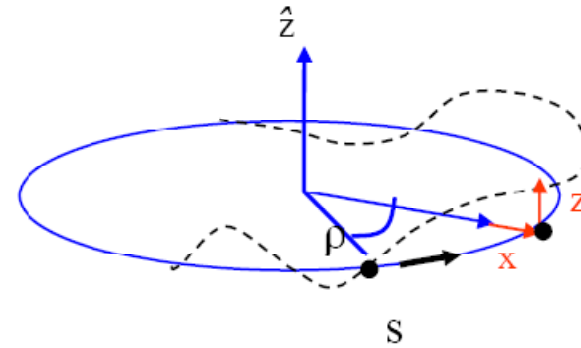

remember:  $x \approx mm$ ,  $\rho \approx m$  ...  $\rightarrow$  develop for small  $x$

$$m \frac{d^2 x}{dt^2} - \frac{mv^2}{\rho} \left(1 - \frac{x}{\rho}\right) = -e B_z v$$

consider only linear fields, and change independent variable:  $t \rightarrow s$   $B_z = B_0 + x \frac{\partial B_z}{\partial x}$

$$x'' - \frac{1}{\rho} \left(1 - \frac{x}{\rho}\right) = \frac{-e B_0}{mv} - \frac{e x g}{mv}$$

$p = p_0 + \Delta p$

... but now take a small momentum error into account !!!

## Dispersion:

develop for small momentum error

$$\Delta p \ll p_0 \Rightarrow \frac{1}{p_0 + \Delta p} \approx \frac{1}{p_0} - \frac{\Delta p}{p_0^2}$$

$$x'' - \frac{1}{\rho} + \frac{x}{\rho^2} \approx \underbrace{\frac{-e B_0}{p_0}}_{-\frac{1}{\rho}} + \frac{\Delta p}{p_0^2} e B_0 - \underbrace{\frac{x e g}{p_0}}_{k * x} + \underbrace{x e g \frac{\Delta p}{p_0^2}}_{\approx 0}$$

$$x'' + \frac{x}{\rho^2} - kx = \frac{\Delta p}{p_0} * \frac{1}{\rho}$$

$$x'' + x \left( \frac{1}{\rho^2} - k \right) = \frac{\Delta p}{p_0} * \frac{1}{\rho}$$

**Momentum spread of the beam adds a term on the r.h.s. of the equation of motion.**  
**→ inhomogeneous differential equation.**

## ***Dispersion:***

$$x'' + x\left(\frac{1}{\rho^2} - k\right) = \frac{\Delta p}{p} \cdot \frac{1}{\rho}$$

***general solution:***

$$x(s) = x_h(s) + x_i(s)$$

$$\begin{cases} x_h''(s) + K(s) \cdot x_h(s) = 0 \\ x_i''(s) + K(s) \cdot x_i(s) = \frac{1}{\rho} \cdot \frac{\Delta p}{p} \end{cases}$$

***Normalise with respect to  $\Delta p/p$ :***

$$D(s) = \frac{x_i(s)}{\frac{\Delta p}{p}}$$

## ***Dispersion function $D(s)$***

- \* is that special orbit, an ideal particle would have for  $\Delta p/p = 1$***
- \* the orbit of any particle is the sum of the well known  $x_\beta$  and the dispersion***
- \* as  $D(s)$  is just another orbit it will be subject to the focusing properties of the lattice***

### Example: Drift

$$M_{Drift} = \begin{pmatrix} 1 & l \\ 0 & 1 \end{pmatrix}$$

$$M_{Drift} = \begin{pmatrix} 1 & l & 0 \\ 0 & 1 & 0 \\ 0 & 0 & 1 \end{pmatrix}$$

$$D(s) = S(s) \underbrace{\int_{s_0}^{s_1} \frac{1}{\rho} C(\tilde{s}) d\tilde{s}}_{=0} - C(s) \underbrace{\int_{s_0}^{s_1} \frac{1}{\rho} S(\tilde{s}) d\tilde{s}}_{=0}$$

### Example: Dipole

$$M_{Dipole} = \begin{pmatrix} \cos \frac{l}{\rho} & \rho \sin \frac{l}{\rho} \\ -\frac{1}{\rho} \sin \frac{l}{\rho} & \cos \frac{l}{\rho} \end{pmatrix}$$

→

$$D(s) = \rho \cdot \left(1 - \cos \frac{l}{\rho}\right)$$
$$D'(s) = \sin \frac{l}{\rho}$$



## 4.) Momentum Compaction Factor:

The *dispersion function* relates the *momentum error* of a particle to the *horizontal orbit coordinate*.

*inhomogeneous differential equation*

$$x'' + K(s) * x = \frac{1}{\rho} \frac{\Delta p}{p}$$

*general solution*

$$x(s) = x_{\beta}(s) + D(s) \frac{\Delta p}{p}$$

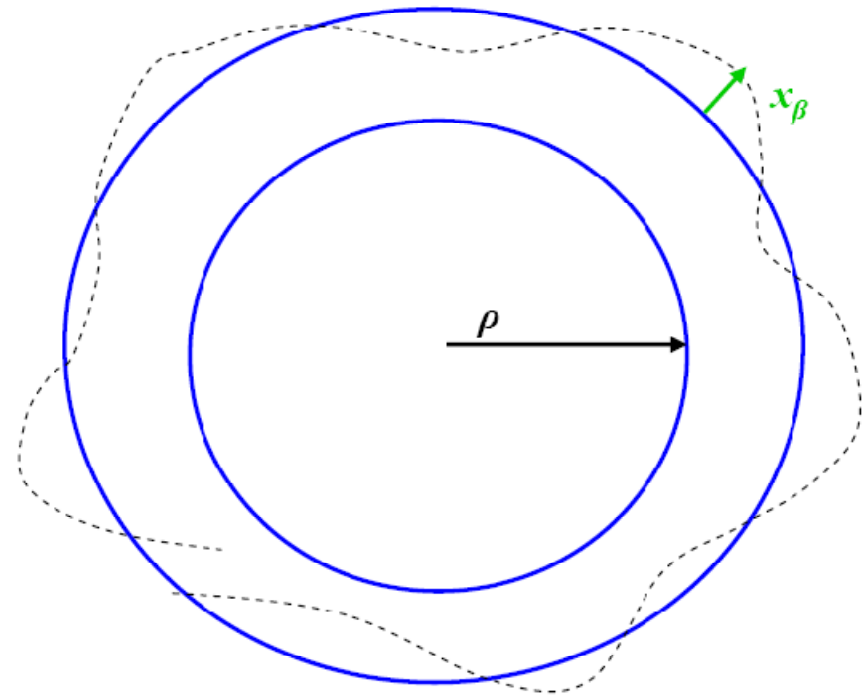

*But it does much more:*

*it changes the length of the **off - energy - orbit !!***

*particle with a displacement  $x$  to the design orbit  
 → path length  $dl$  ...*

$$\frac{dl}{ds} = \frac{\rho + x}{\rho}$$

$$\rightarrow dl = \left( 1 + \frac{x}{\rho(s)} \right) ds$$

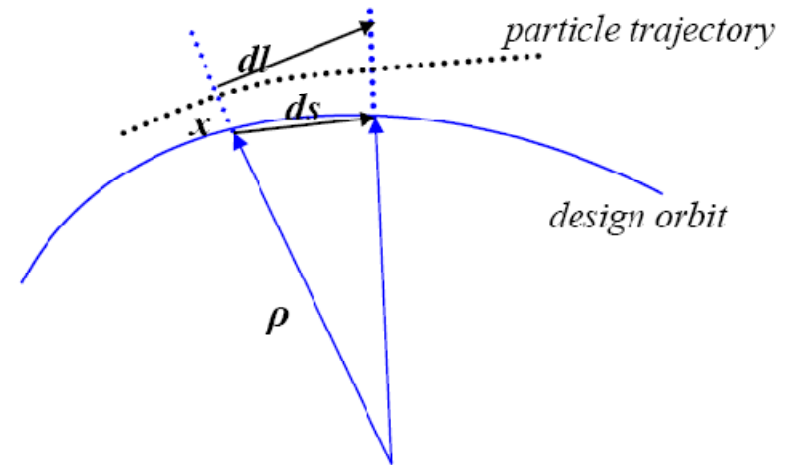

*circumference of an off-energy closed orbit*

$$l_{\Delta E} = \oint dl = \oint \left( 1 + \frac{x_{\Delta E}}{\rho(s)} \right) ds$$

*remember:*

$$x_{\Delta E}(s) = D(s) \frac{\Delta p}{p}$$

$$\delta l_{\Delta E} = \frac{\Delta p}{p} \oint \left( \frac{D(s)}{\rho(s)} \right) ds$$

*\* The lengthening of the orbit for off-momentum particles is given by the dispersion function and the bending radius.*

**Definition:**  $\frac{\delta l_\varepsilon}{L} = \alpha_{cp} \frac{\Delta p}{p}$

$$\rightarrow \alpha_{cp} = \frac{1}{L} \oint \left( \frac{D(s)}{\rho(s)} \right) ds$$

**For first estimates assume:**  $\frac{1}{\rho} = \text{const}$

$$\int_{\text{dipoles}} \mathbf{D}(s) ds = \Sigma (l_{\text{dipoles}}) * \langle \mathbf{D} \rangle_{\text{dipole}}$$

$$\alpha_{cp} = \frac{1}{L} l_{\text{dipoles}} \langle D \rangle \frac{1}{\rho} = \frac{1}{L} 2\pi\rho \langle D \rangle \frac{1}{\rho} \rightarrow \alpha_{cp} \approx \frac{2\pi}{L} \langle D \rangle \approx \frac{\langle D \rangle}{R}$$

**Assume:**  $v \approx c$

$$\rightarrow \frac{\delta T}{T} = \frac{\delta l_\varepsilon}{L} = \alpha_{cp} \frac{\Delta p}{p}$$

$\alpha_{cp}$  combines via the dispersion function the momentum spread with the longitudinal motion of the particle.

## Resume':

*beam emittance:*

$$\varepsilon \propto \frac{1}{\beta\gamma}$$

*$\Delta p/p \neq 0$  inhomogeneous equation:*

$$x'' + x \left( \frac{1}{\rho^2} - k \right) = \frac{\Delta p}{p_0} * \frac{1}{\rho}$$

*... and its solution:*

$$x(s) = x_\beta(s) + D(s) \cdot \frac{\Delta p}{p}$$

*dispersion in a sector dipole:*

$$D(s) = \rho \cdot \left( 1 - \cos \frac{l}{\rho} \right) \quad D'(s) = \sin \frac{l}{\rho}$$

*3x3 transformation matrix:*

$$\begin{pmatrix} x \\ x' \\ \Delta p/p \end{pmatrix}_s = \begin{pmatrix} C & S & D \\ C' & S' & D' \\ 0 & 0 & 1 \end{pmatrix} \cdot \begin{pmatrix} x \\ x' \\ \Delta p/p \end{pmatrix}_0$$

*momentum compaction:*

$$\frac{\delta l_\varepsilon}{L} = \alpha_{cp} \frac{\Delta p}{p}$$

$$\alpha_{cp} \approx \frac{2\pi}{L} \langle D \rangle \approx \frac{\langle D \rangle}{R}$$

# Chromaticity

- ❖ **Chromaticity** refers to effects caused by a momentum dependence. The name arises because the momentum of an ion is closely analogous to the frequency, and hence the colour, of light in classical optics.
- ❖ The dispersion function that arises from the differential bending in dipoles for ions of different momenta is strictly a chromaticity effect, but it is not referred to as such.
- ❖ The effect arising from the differential focusing with momentum causes the betatron phase advance or tune in a ring to change with momentum. This is generally known as the chromaticity and can be defined in two ways:

$$Q' = \frac{\Delta Q}{\Delta p / p} \quad \text{or} \quad Q' = \frac{\Delta Q / Q}{\Delta p / p} \quad (22)$$

The first definition is the more widely used, but the second definition is liked for its symmetry.

- ❖ The next level of chromaticity is the variation of  $\alpha$  and  $\beta$  with momentum. This is treated by formulating a so-called *w-vector*, which is too advanced to be tackled here.

***LONGITUDINAL***

***PLANE***

- ❖ In a ring, the RF period will be related to the revolution period by a factor called the harmonic number,  $h$ ,

$$h = \frac{\text{Revolution period}}{\text{RF period}} \quad (7)$$

- ❖ In most cases, the time to cross the gap will be very small compared to the RF period and the ion will be fully relativistic, so that the Transit Time Factor will be close to unity.

- ❖ In this case, the energy gained by the beam will be,

$$\Delta_s E = q V_{\text{RF}} \sin \phi_s \quad (8)$$

[ $\phi_s$  refers to the synchronous ion]

- ❖ The harmonic number,  $h$  sets the number of RF oscillations in one revolution. There will be one stable RF bucket per RF oscillation, i.e.  $h$  buckets and correspondingly up to  $h$  bunches in the machine.

$$f_{\text{Rev}} = \frac{1}{T_{\text{Rev}}} = \frac{\beta c}{2\pi R}$$

$$f_{\text{RF}} = \frac{ch}{2\pi R} \sqrt{1 - \frac{1}{(1 + T/E_0)^2}}$$

- ❖ The magnetic field ramp is the ‘driving’ parameter behind the RF programmes for  $f_{\text{RF}}$ ,  $V_{\text{RF}}$  and  $\phi_s$ .
- ❖ Fast cycling machines have resonant power supplies.

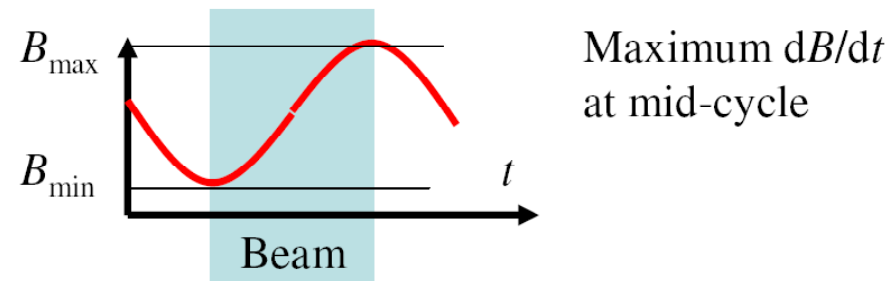

- ❖ Slow cycling machines are ‘ramp and hold’

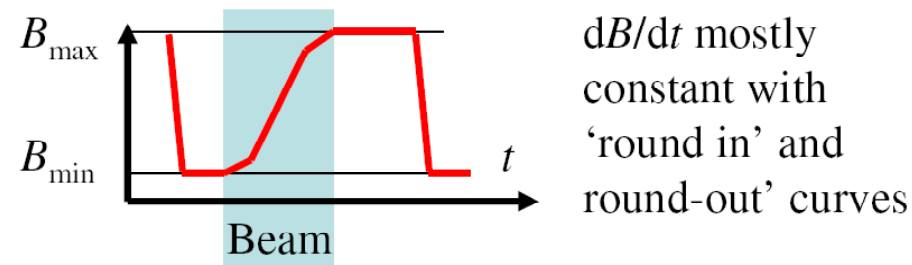



# Phase stability

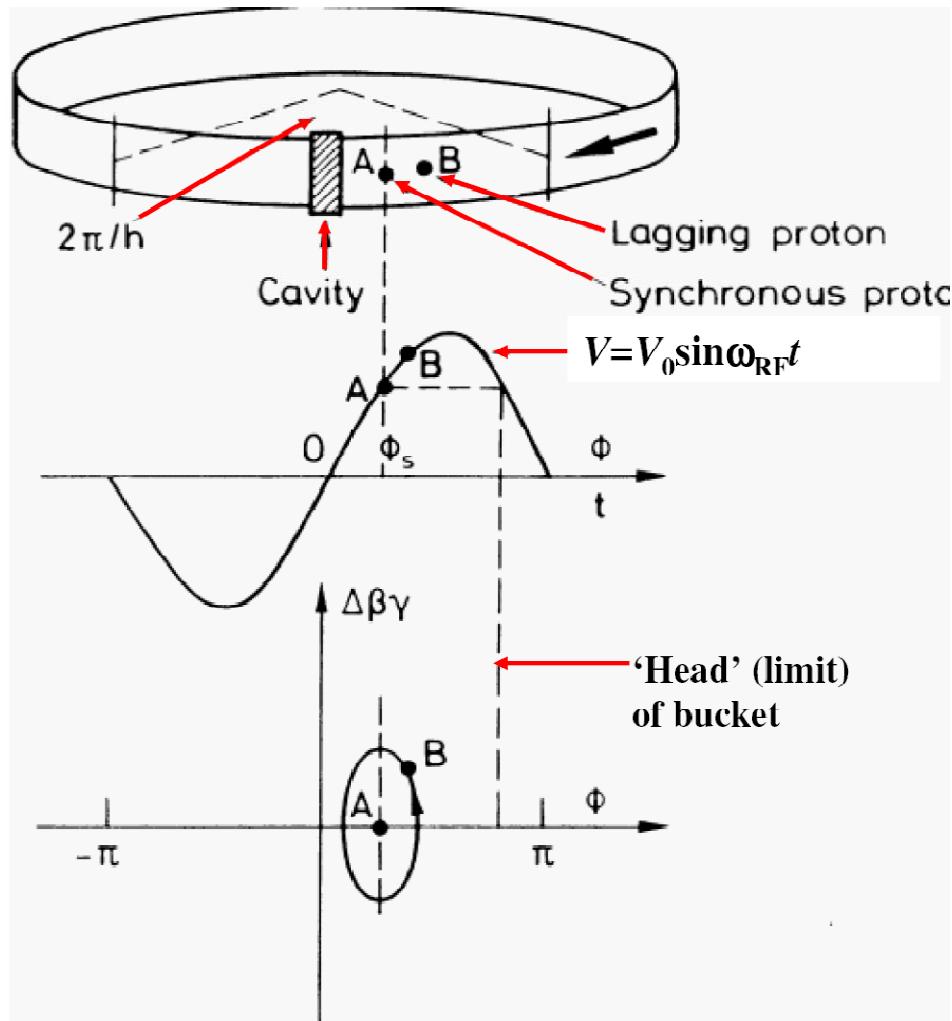

**Below transition** This case is intuitive.

- ❖ Lag behind - get more energy - catch up.
- ❖ Get ahead - need less energy - fall back.

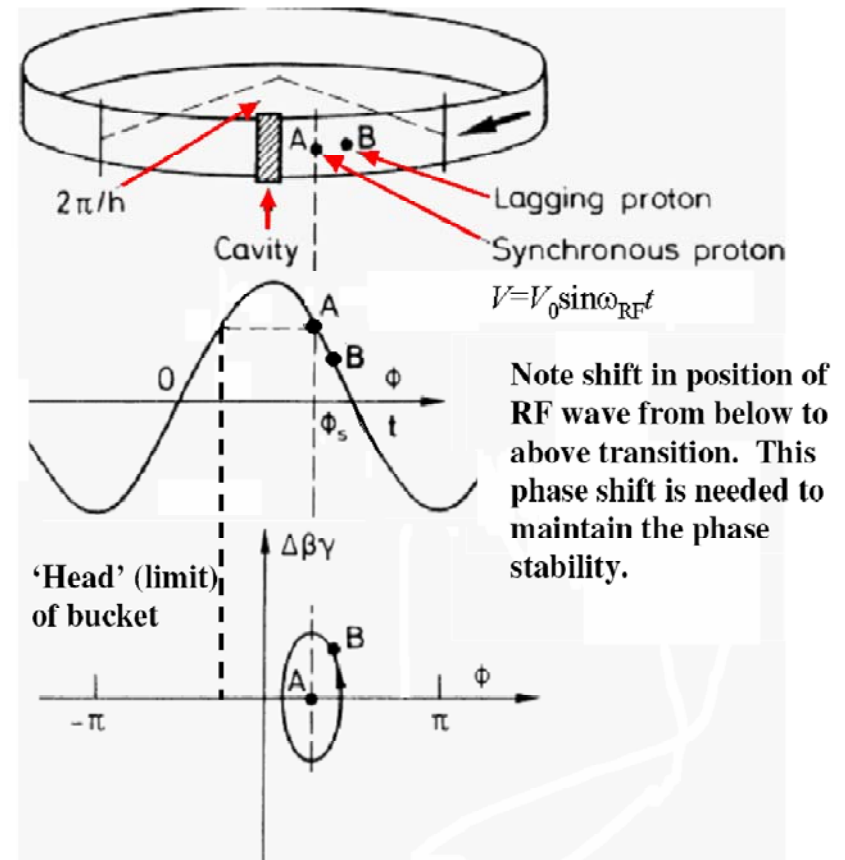

**Above transition** This case is not intuitive.

- ❖ Lag behind - need less energy - catch up.
- ❖ Get ahead - get more energy - fall back.

### 3.2 - SYNCHRONOUS PARTICLE

Figure 14 illustrates the possible effect of a sinusoidal voltage applied to two particles according to the respective phases.

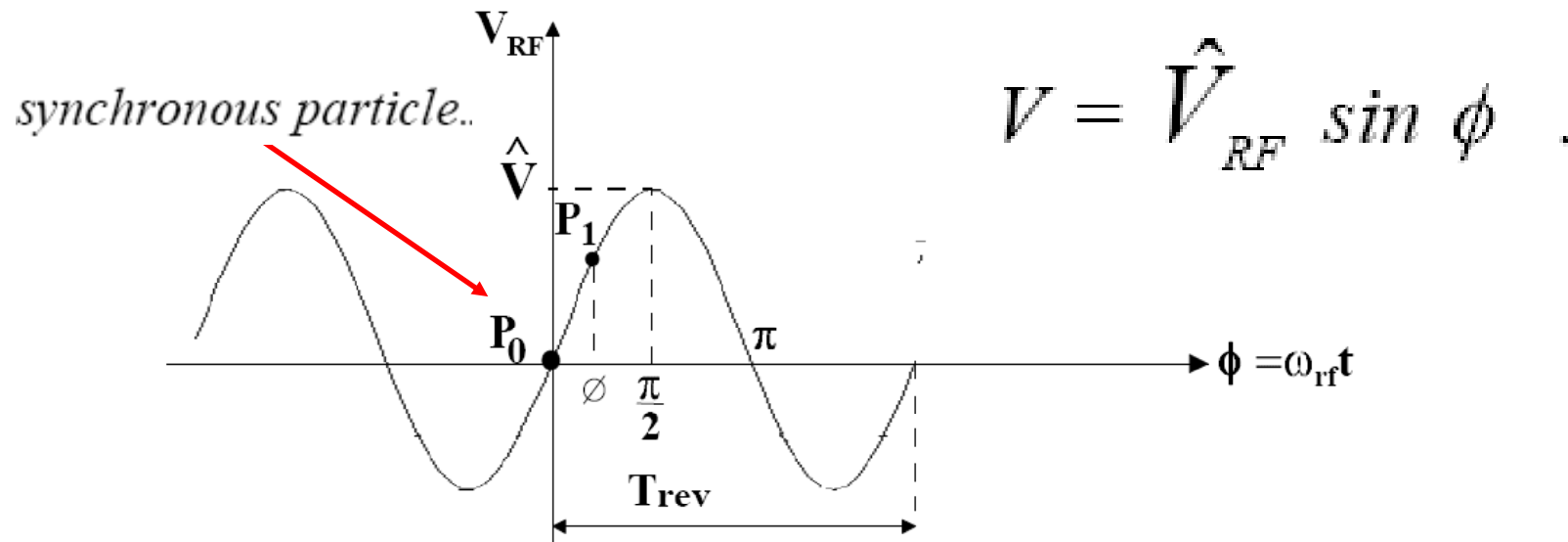

Figure 14: Sinusoidal voltage applied to two particles

( $\phi = 0$  is at zero crossing for synchrotron)

Let us consider a particle  $P_0$  turning in a synchrotron with an energy below the transition ( $\eta > 0$ ). At each turn, it crosses a RF cavity with the voltage

If the revolution frequency of  $P_0$  is equal to the RF frequency, and if  $P_0$  arrives at the time  $t = 0$  (phase zero), this particle is neither accelerated, nor decelerated.

### 3.4 - PRINCIPLE OF PHASE STABILITY

In the previous paragraph, we have considered a particle  $P_0$  arriving in the RF cavity with a phase  $\phi_0 = 0$ .

Let us consider now a particle  $P_1$  arriving with a phase different to zero (Fig. 16).

The energy gain is :

$$\Delta E = e \hat{V}_{RF} \sin \phi_1 \quad . \quad (73)$$

The velocity increases. Assuming  $\eta > 0$  (below the transition), the path length increases, the revolution period decreases and the revolution frequency increases.

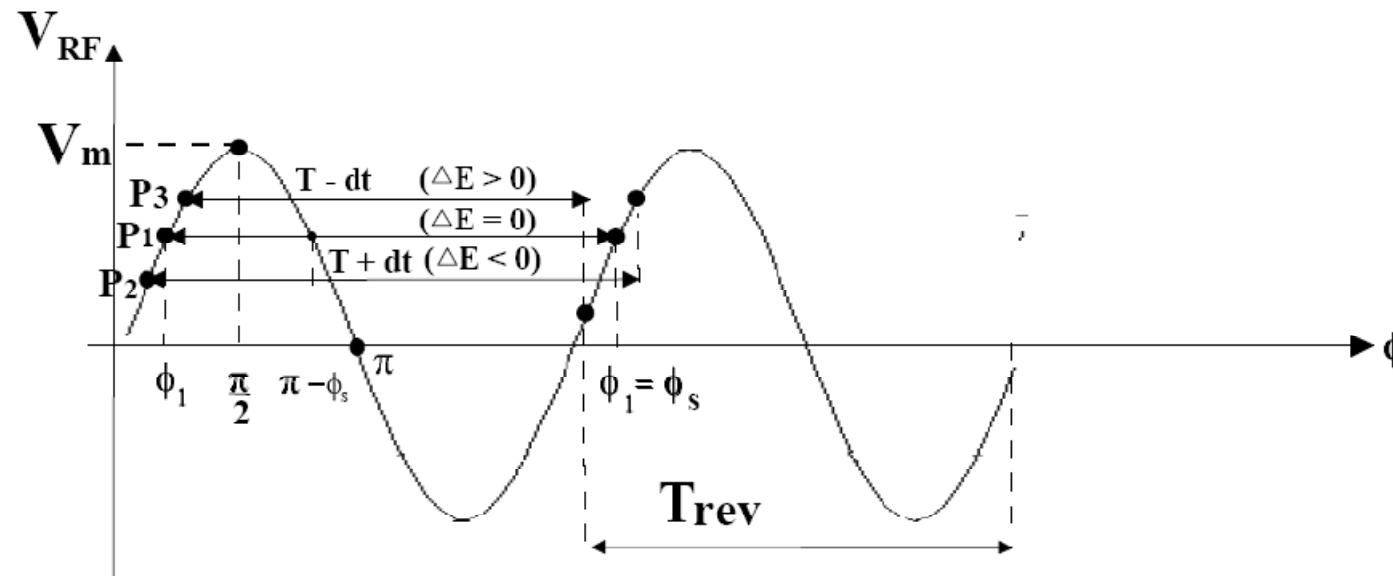

Figure 16: Synchronous particle with  $\phi_s \neq 0$  and  $\eta > 0$

This separatrix determines the RF bucket (Fig. 17)

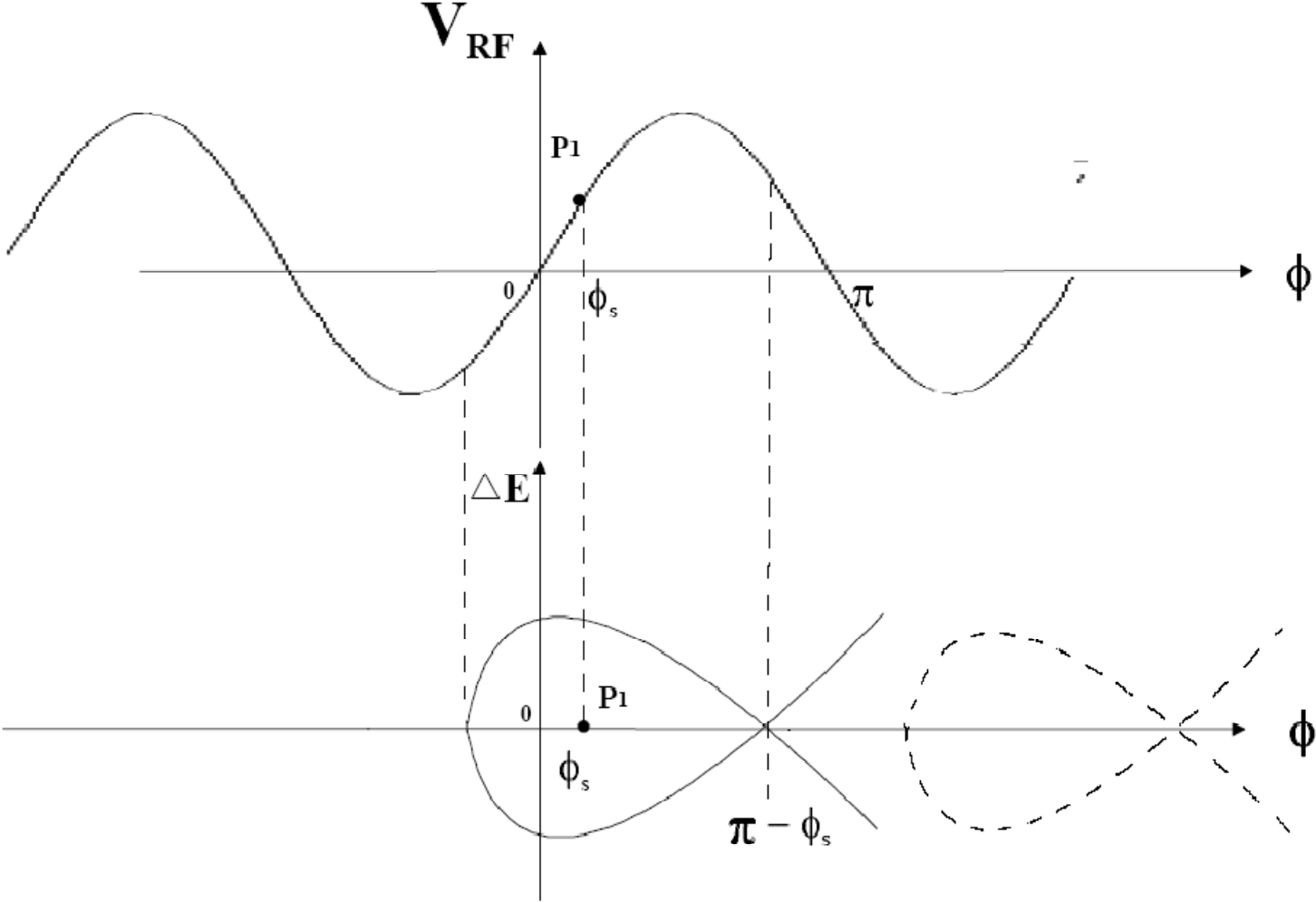

Figure 17: Amplitude variations and RF bucket

From (92) and (99), the motion of the non-synchronous particle is given by the system of differential equations :

$$\left\{ \begin{array}{l} \frac{d(\Delta p)}{dt} = \frac{e\hat{V}_{RF}}{2\pi R_s} (\sin\phi - \sin\phi_s) \\ \frac{d\phi}{dt} = -\frac{\eta h \omega_s}{p_s} \Delta p \end{array} \right. \quad (100)$$

$$\left\{ \begin{array}{l} \frac{d\phi}{dt} = -\frac{\eta h \omega_s}{p_s} \Delta p \end{array} \right. \quad (101)$$

the variables are the momentum  $\Delta p$  and the phase  $\phi$ .

A simplified expression is given by :

$$\left\{ \begin{array}{l} \frac{d(\Delta p)}{dt} = A (\sin\phi - \sin\phi_s) \\ \frac{d\phi}{dt} = B \Delta p \end{array} \right. \quad (102)$$

$$\left\{ \begin{array}{l} \frac{d\phi}{dt} = B \Delta p \end{array} \right. \quad (103)$$

where

$$A = \frac{e\hat{V}_{RF}}{2\pi R_s} \quad (104)$$

$$B = -\frac{\eta h \omega_s}{p_s} = -\frac{\eta h \beta_s c}{p_s R_s} \quad (105)$$

## SMALL AMPLITUDE OSCILLATIONS

Equation (102) can be written :

$$\frac{d}{dt} \left[ \frac{1}{B} \frac{d\phi}{dt} \right] - [A] (\sin \phi - \sin \phi_s) = 0 \quad . \quad (106)$$

We assume that variations in time of quantities between square brackets are slow compared to the variations  $\Delta\phi = \phi - \phi_s$ .

Hence equation (106) becomes in the first approximation ( $B \neq 0$ ) :

$$\frac{d^2\phi}{dt^2} + \frac{\Omega_s^2}{\cos\phi_s} (\sin\phi - \sin\phi_s) = 0 \quad (107)$$

where

$$\Omega_s^2 = -A B \cos \phi_s = \frac{e \hat{V}_{RF} \eta h \beta_s c}{2 \pi p_s R_s^2} \cos \phi_s \quad (108)$$

or 
$$\Omega_s^2 = \Omega_0^2 \cos \phi_s \quad . \quad (109)$$

$$\frac{d^2\phi}{dt^2} + \Omega_0^2 (\sin \phi - \sin \phi_s) = 0$$

### 4.3.2 Second approximation

We consider particles which remain close to the synchronous particle. Their variations in phase and in energy are small. We develop  $\sin \phi$  :

$$\sin \phi = \sin (\phi_s + \Delta \phi) = \sin \phi_s \cos \Delta \phi + \cos \phi_s \sin \Delta \phi$$

To the first order :

$$\begin{aligned} \sin \phi &\cong \sin \phi_s + \cos \phi_s \Delta \phi \\ \text{and} \quad (\sin \phi - \sin \phi_s) &\cong \Delta \phi \cos \phi_s \quad . \end{aligned}$$

To the second order :

$$\frac{d^2 \phi}{dt^2} = \frac{d^2 (\Delta \phi)}{dt^2} \quad .$$

Under these assumptions, (107) becomes :

$$\frac{d^2 (\Delta \phi)}{dt^2} + \Omega_s^2 \Delta \phi = 0 \quad . \quad (113)$$

For small amplitude oscillations, we obtain the equation of a harmonic oscillator where  $\Omega_s$  is the angular frequency.

## Stability condition

$$\eta \cos \phi_S > 0$$

$$\gamma < \gamma_{tr}, \quad \eta > 0, \quad \cos \phi_S > 0, \quad 0 < \phi_S < \frac{\pi}{2}$$

$$\gamma > \gamma_{tr}, \quad \eta < 0, \quad \cos \phi_S < 0, \quad \frac{\pi}{2} < \phi_S < \pi .$$



