

# General Status of Beam Instrumentation

JJ Gras on behalf of BE/BI

- *Status of new wire scanners*
- *TT2 couplers: what is needed to make them operational?*
- *Status of beam current transformers*
- *Status of LHC BLMs: actual and expected performance*

# Status of New Wire Scanners

BWS – BPM – BCT – BLM – Conclusions

- **Goal of the Project:**
  - Decrease the aperture restrictions due to the horizontal scanner tanks in the PS machine.
  - Install an additional horizontal scanner in the SS68.
  - Allow calibration on an extended range ( $\pm 50$  mm)

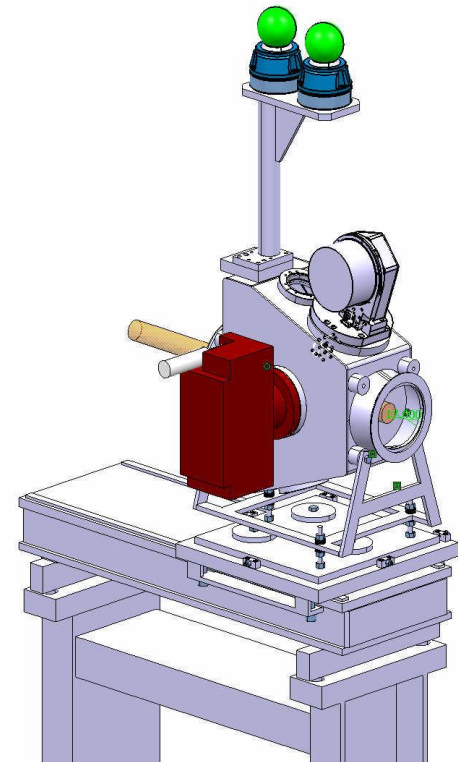

# *Status of New Wire Scanners*

BWS – BPM – BCT – BLM – Conclusions

- Design discussed and agreed with OP, ABP and impedance and vacuum experts.
- 6 new tanks will be made.
  - 2 are in production now. They'll be ready for the end of November
  - Last 4 will be made in 2011.
- The optical bench to calibrate these scanners on an extended range (+/- 50mm) will also be ready by the end of November and installed in 588.
- 2 additional fast wire scanner mechanisms will also be produced to keep a correct situation for spares.

# *Status of New Wire Scanners*

BWS – BPM – BCT – BLM – Conclusions

- In addition, we plan to install one pick up next to each horizontal scanners to allow:
  - Quick calibration check
  - Monitoring of possible degradation of the calibration
- 3 pick ups have been ordered by Jeroen to cover this need.

# *Status of New Wire Scanners*

BWS – BPM – BCT – BLM – Conclusions

- The plan is to:
  - Install a new PS horizontal wire scanner in SS68 during Christmas technical stop, including the extra pick up.
  - Replace the 4 current PS tanks by the new ones during 2012 long shutdown. If the experience with the neighboring pick up is positive, we will also equip SS54 and SS64 H wire scanner with one.

# Status of New Wire Scanners

BWS – BPM – BCT – BLM – Conclusions

- Finally, we agreed with OP to apply more systematic approach to assess the wire scanners performance and behavior over time. This will be based on:
  - agreed and stable test conditions and procedures (yet to be published) covering most important use cases (main USERS/Beams)
  - Systematic comparison with SEM grids and dp/p measurements.

# TT2 couplers: what is needed to make them operational?

BWS – BPM – BCT – BLM – Conclusions

- Most BPMs in TT02/TT10 (16 over 20) are on SPS timing and controlled via a dedicated BI FESA class.
- The other 4 in TT02 are controlled via samplers on PS timing to
  - cover all beam extracted from the PS
  - allow position measurement for the 5 PS turns.
- The current implementation of these 4 BPMs makes it difficult to have them “operational”, i.e.:
  - Calibrated regularly and precisely.
  - Integrated into YASP for easy and efficient steering.

# TT2 couplers: what is needed to make them operational?

BWS – BPM – BCT – BLM – Conclusions

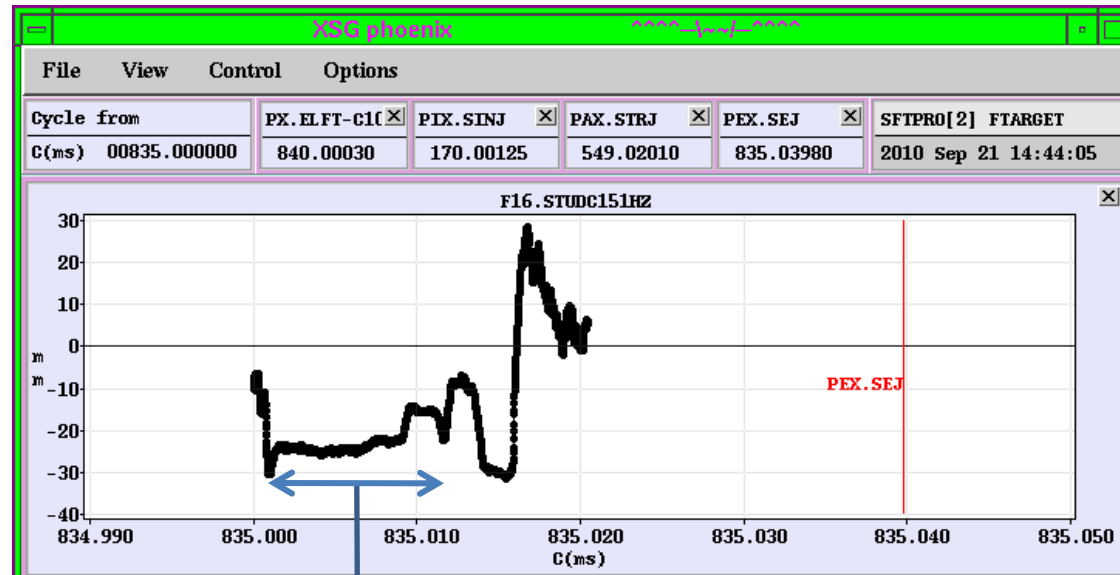

- The electronics is based on logAmp hiding the signal intensity information
- Here are the 5 turns sampled at 200 MS/s.
- The rest is logAmps amplifying noise.
- The 5 turn positions can nevertheless be derived by averaging around predefined time markers.
- Samplers, as generic devices, cannot implement these specific treatments in the front end.



# *TT2 couplers: what is needed to make them operational?*

BWS – BPM – BCT – BLM – Conclusions

**A word on calibration** for these 4 BPMs separated from their BI acquisition server:

- Calibration of these 4 BPMs has to be done manually from surface building in collaboration with OP in CCC. **This is working** (and Thierry is convinced that the results of the last calibration are correct and still valid) **but is very heavy**.
- We have no precise assessment of the accuracy of our measurements except for cross-checks made by OP (BTV, bumps) on TT10 who declared **the results as correct and coherent**.

## **A word on the integration in YASP**

- This is not straightforward for 2 reasons:
  - Sampler gives a 200 MS/s position spill based on the BPM logAmp result. This would have to be reduced to 1 position per turn to be swallowed by the steering algorithm.
  - YASP is currently limited to one position per extraction
- The feasibility of this is currently investigated by Marine and Joerg but BI cannot help much on the current implementation.

# TT2 couplers: what is needed to make them operational?

BWS – BPM – BCT – BLM – Conclusions

- BI had for some time the plan to renovate this system based on the current CNGS transfer line implementation.
  - The proposed solution would have solved the timing domain problem and allow an easy integration in current PS and SPS YASP (1 point per extraction)
  - But it would not have provided a position per PS turn.
- We are currently designing a new electronics to cover all these needs. **We plan to test a prototype next year and have the new system deployed during 2013 start-up.**
- Any possible adaptation of YASP to 5 turn acquisition and correction done in the meantime will still be valid.

# Status of Beam Current Transformers

BWS – BPM – **BCT** – BLM – Conclusions

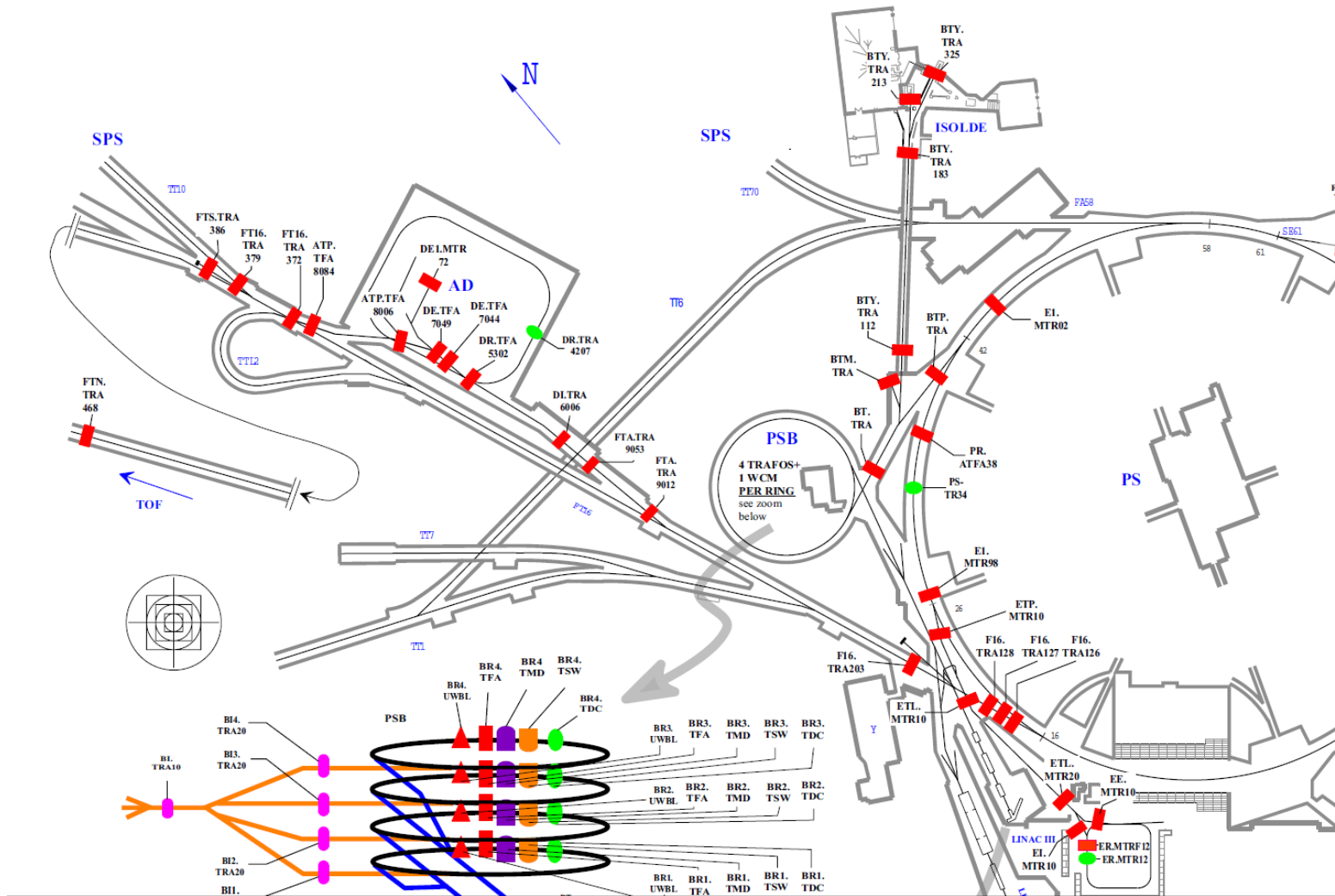

# Status of Beam Current Transformers

BWS – BPM – BCT – BLM – Conclusions

- **We clearly understand OP's interest** to get a good absolute accuracy on the different BCTs in the PS complex.
- Unfortunately, the current diversity of monitors combined with a serious human resource problem (old PS team is now also responsible for SPS and LHC BCTs) makes it difficult to achieve.
- **Today, an absolute accuracy to quantify the losses at 1% level looks out of reach** but we do think that we should be able to achieve soon **a short term relative accuracy from shot to shot within the 1% rms** to optimize machine performance

# Status of Beam Current Transformers

BWS – BPM – **BCT** – BLM – Conclusions

Total intensities for MD4 beam (06/09 22:00 -> 07/09 01:00)

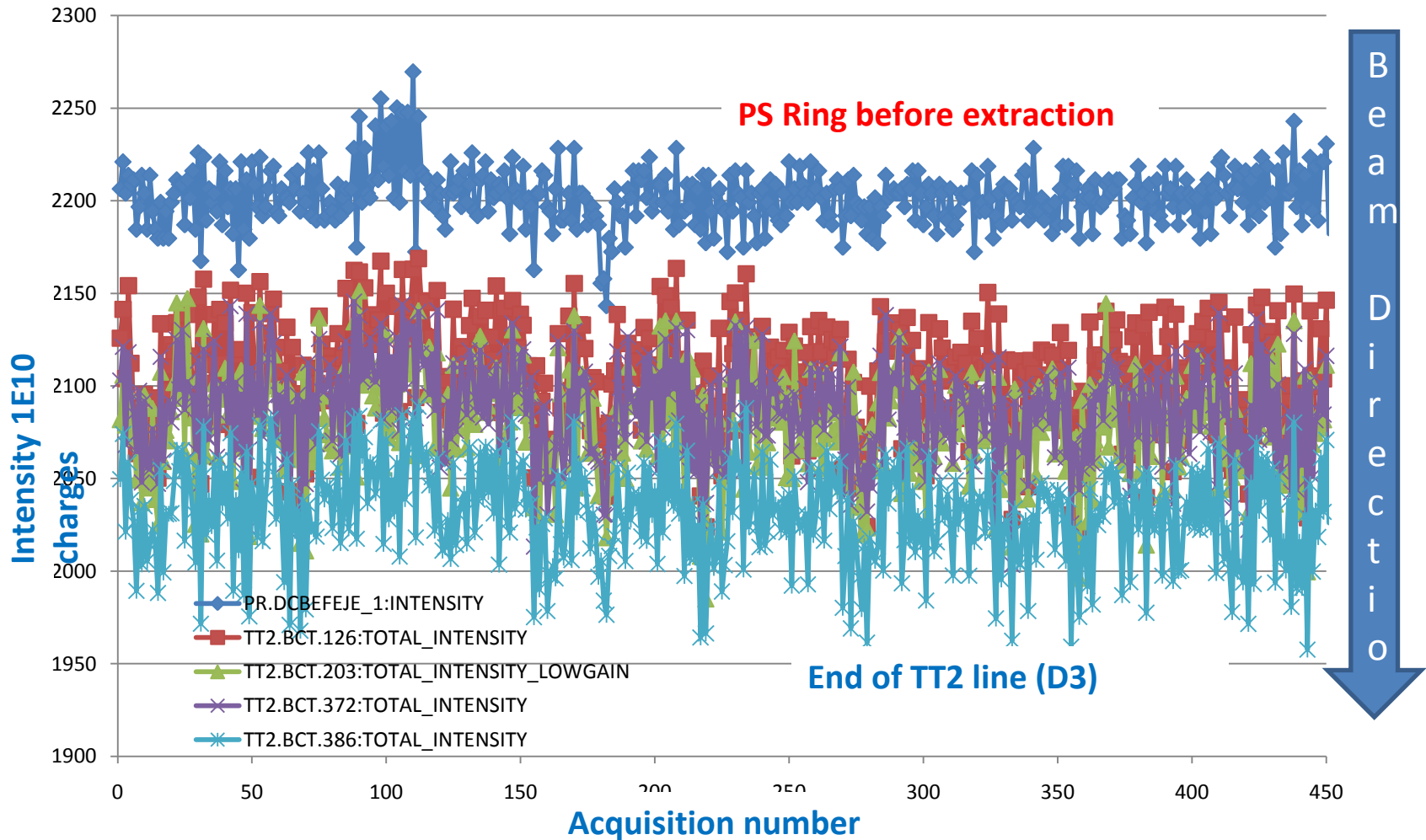

# Comments on BCTs in TT2

MD4\_September\_16\_Noise

$\times 10^{13}$   
2.3

Massimo's slide showed a less favorable example this morning on data taken ten days after.

This has to be investigated but what we suspect there is a shift at the analog fast trigger controlling the acquisition window. If this is shifted (and this is not under BI control), then the integration over the acquisition window will be lower.

Has this been checked this day?

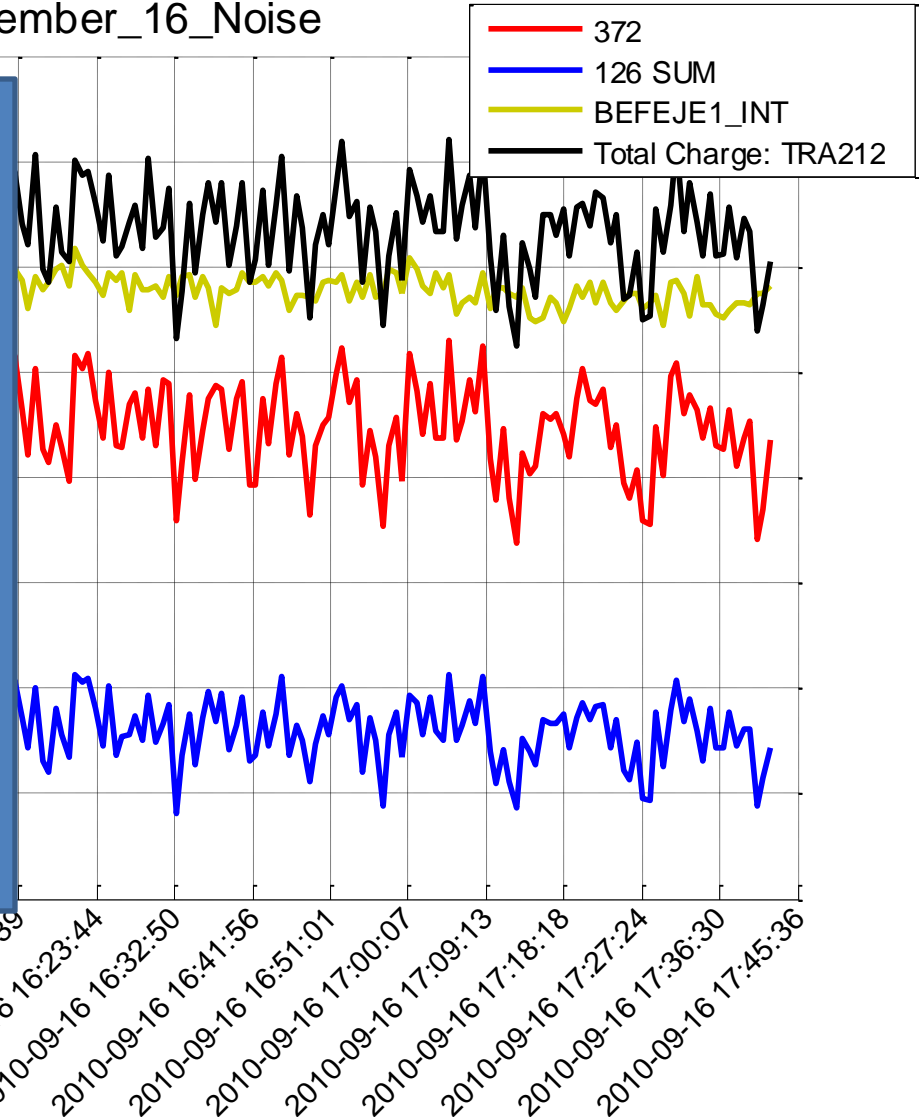

# Status of Beam Current Transformers

BWS – BPM – BCT – BLM – Conclusions

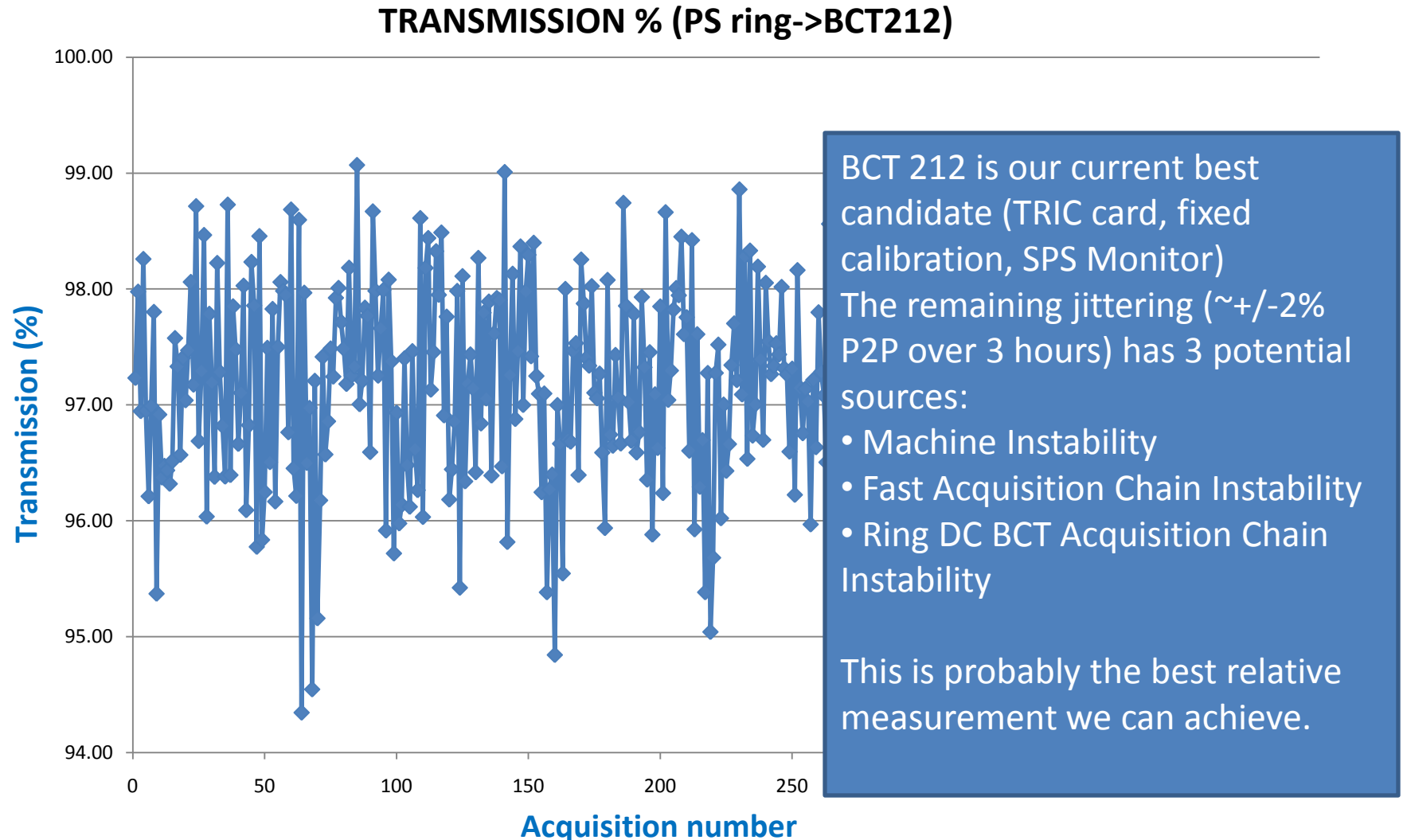



# Status of Beam Current Transformers

BWS – BPM – BCT – BLM – Conclusions

- The short term actions to improve the situation are the following:
  - We re-calibrated DC BCT (1,5 year old). This should give us now ~1% rms absolute accuracy on ring DC BCT for high intensity beams
  - We will disable the pulse to pulse recalibration of the fast BCTs that introduces an artificial 1% variation. This should eventually allow to get a 1%rms relative accuracy from shot to shot to tune the machine.

# Status of Beam Current Transformers

BWS – BPM – BCT – BLM – Conclusions

- But 3 main sources of errors still remain:
  - the uncertainty on fast BCT absolute calibration inherent to the TRIC card components (calculated around 1.5% rms) and currently varying from TRIC to TRIC.
  - The poor quality of the existing amplifiers that can lead to signal distortion of several %.
  - The quality of some old monitors
- For this, the medium term actions are:
  - Build a calibration bench to cross-calibrate all TRIC card during Christmas shutdown (CSD) and:
    - Eliminate the 1.5% spread between them.
    - Reduce the resulting absolute uncertainty
  - Test a new amplifier (to be installed W44 in 203) that should eliminate distortions but also allow low intensity beam observation and deploy it during the CSD.

# *Status of Beam Current Transformers*

BWS – BPM – **BCT** – BLM – Conclusions

- On a longer term, we also plan to **standardize** our fast BCT monitors to our most performant one, i.e. **the SPS type**.
- This could happen during 2012 long shutdown, depending on budget approval.

# *Status of LHC BLMs: actual and expected performance*

BWS – BPM – BCT – **BLM** – Conclusions

- The BCT situation puts extra pressure on BLM requirements in injection and extraction regions
- I'll not come back to the currently available BLM performance already described but concentrate on the result of our recent discussions.

# Status of LHC BLMs: actual and expected performance

BWS – BPM – BCT – BLM – Conclusions

- It is clear that the MTE extreme requirements (fast response and high dynamics) can not be covered by a single monitor and that our previous assumptions for the BLM renovation have to be reviewed (including cable policy)
- We have already installed different types of monitors with various performance (ACEM, Cerenkov, SEM). They are currently assessed.
- We will install our last type (short LHC ionisation chamber) during W44.

# Status of LHC BLMs: actual and expected performance

BWS – BPM – BCT – BLM – Conclusions

- Our educated guess is that these monitors will be able to cover the different needs. (n.b. we expect ACEM to have a performance close to diamond monitors and they will be less expensive [Bernd D.] )
- We will then review the functional specifications with OP/ABP to clarify what is need where and derive a technical specifications from there based on these tests.
- The goal is to have a first draft of technical specifications ready for Q1 2011 so that we can update the requested budget accordingly.

# Ring Trajectories at Extraction

BWS – BPM Extra – BCT – BLM – Conclusions

- We recorded your request for PS trajectories just before extraction.
- This is currently not possible (system blind at 200 MHz)
- We'll trigger an ad-hoc discussion with OP, ABP and our experts to see what we could do to answer the underlying question:
  - Is the extraction energy stable?

# Conclusions

BWS – BPM – BCT – BLM – Conclusions

- We take this opportunity of demanding MTE operation to improve the functional specifications of instruments under renovation but also understand better the existing ones.
- In this context, **current support from OP for measurements is extremely valuable**. We just would like to optimize this by **putting in place test conditions and procedures** to be able to benefit from these measurements on the long term.
- BI decided to invest one FTE over the 2 coming years (VIA coming 1st of October) on instrument performance assessment. The guy will be pretty busy on LHC but he will also give a hand on the PS.



# Status of LHC BLMs: actual and expected performance

BWS – BPM – BCT – **BLM** – Conclusions

