

EASIER status report

J. Aublin, M. Avenier, C. Bérat, X. Bertou, P. Billoir, C. Bonifazi, J. Chauvin, O. Deligny, **Silvia Gambetta**, P. Ghia, H. Lebbollo, D. Lebrun, I. Lhenry-Yvon, A. Letessier-Selvon, C. Macolino, I. Mariş, F. Montanet, M. Münchmeyer, R. Randriatoamanana, P. Stassi, A. Stutz

Coimbra, 24-9-2010

- Introduction to EASIER
- The prototype detector
- Noise measurements
- Expected signal
- Future plans

Goal

- Improve particle identification of UHECR
- Measure UHECR composition at higher energies
- Measure hadronic cross section at $E_{cm} \geq 100$ TeV
- Constraints and parametrization of interaction models

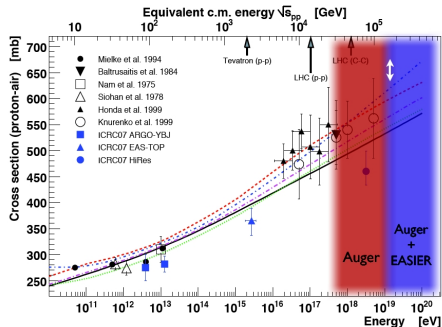
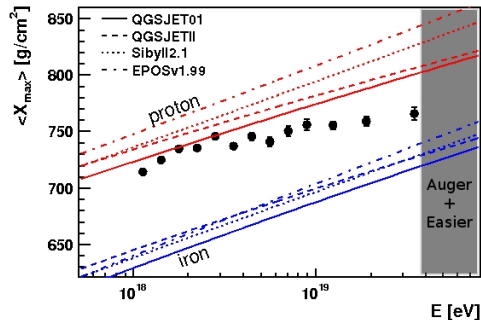

The detector

Extensive Air Shower Identification using Electron Radiometer

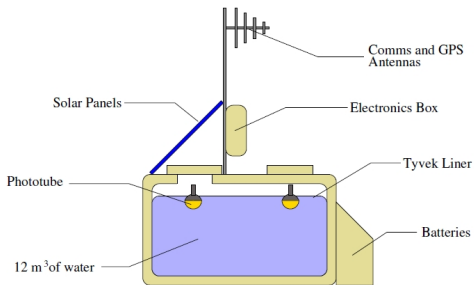

- Integrated radio receiver
- EM component of the shower
- Power trace
- Local DAQ

Summary

- Detection of **radio emission** of the EM cascade
- **Two** possible bands: VHF (10-100 MHz) and C+K (1-10 GHz)
- **Trigger and timing via tank DAQ**

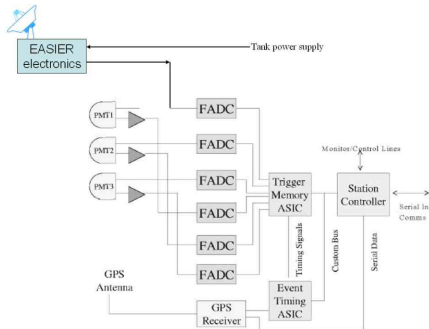
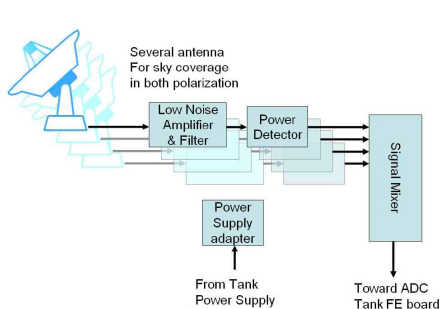

- Signal proportional to the EM energy
- Time shape related to the cascade evolution and X_{max}
- Muonic signal in the tank by subtraction

$\approx 100\%$ duty cycle telescope with the coverage of a surface detector, integrated in the array

VHF band:

- Antenna's selection and test
- Noise evaluation
- Test of the acquisition chain
- Prototype installation
- Data taking and analysis

C+K band:

- Find the best antenna
- Test the whole receiving system and tank connection
- Signal simulations
- Prototype installation
- Data taking and analysis

VHF band: FAT dipole antenna, CODALEMA type

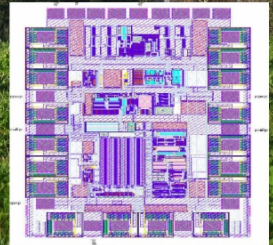

Signal: **geosynchrotron radiation**

$$\mathbf{E} [\mu\text{V/m}] = 178 \frac{E_0}{10^{17} \text{ eV}} (-\mathbf{v} \times \mathbf{B}) \cos \theta \exp\left(\frac{-d}{D_0(\theta)}\right)$$

State of art in the detection:

- Collimated radiation
- Main experiments: LOPES, CODALEMA, AERA
- Large areas at low cost
- Problems in trigger setup
- Actual detectors few hundred meters apart

External trigger can overcome these difficulties

Plan of measurements

Noise measurements:

- Environmental noise
- Constant noise from the tank electronics
- Noise from PMTs signal
- Test of our acquisition chain
- Measurement sensitivity
- Trigger rate

Measurements taken in Orsay (Paris) at the Auger prototype tank

Experimental setup

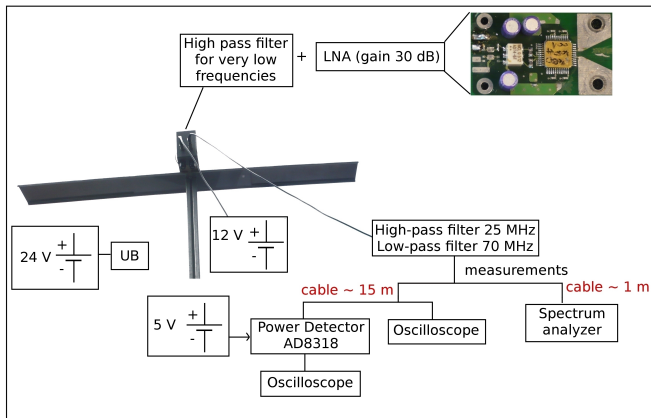

- FAT dipole antenna from the CODALEMA collaboration
- LNA from CODALEMA, gain ~ 30 dB
- Power Detector

Environmental noise

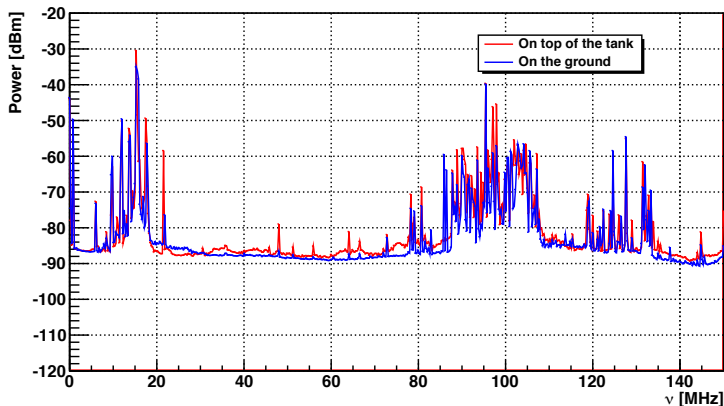

- Noise level on top of the tank of -128 dBm/Hz
- Difference between the spectra of: (1.17 ± 0.17) dBm

Antenna lobes not influenced by the position with respect to the tank

Electric field

Spectrum on top of the tank with filters (25-70 MHz)

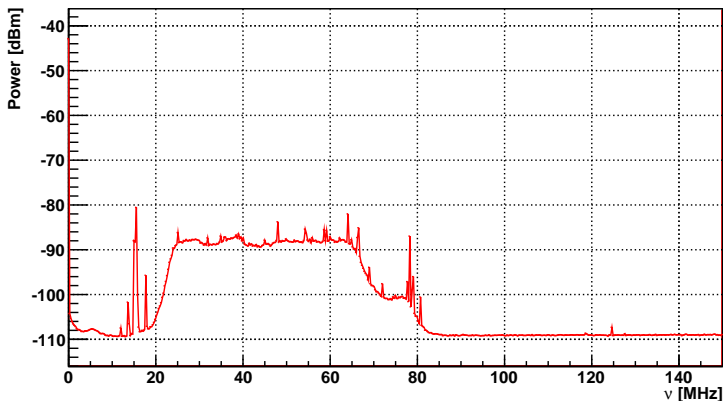

$$P = 7.61 \cdot 10^{-9} \text{ W} \quad E = \frac{U_{out}}{l_{eff}} = 4.11 \cdot 10^{-5} \text{ V/m}$$

Constant noise from the tank

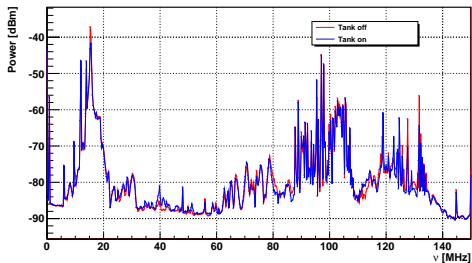

- No emission visible from the PMTs

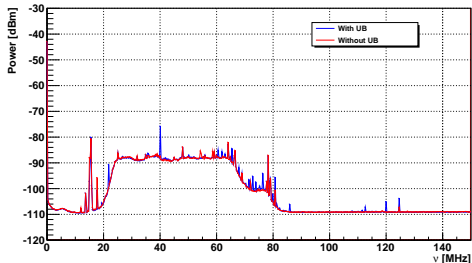

- Noise at 40 MHz from the UB

Noise from PMTs

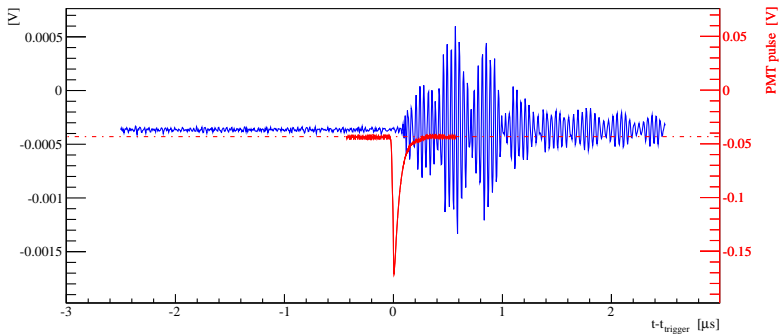

- Traces enregistered when PMTs are triggering
- Antenna close to a PMT
- Signal averaged over 2000 traces

Study of the antenna position

Antenna close to a PMT

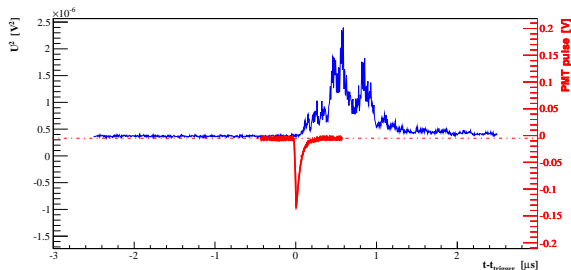

Antenna on top of the tank

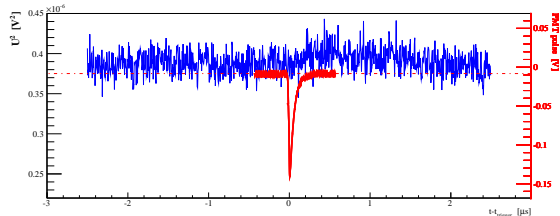

- Squared averaged signal
- Peak value: power in a $1 \mu\text{s}$ sliding window
- Peak value: power in a 100 ns sliding window
- Comparison of the baseline value with the spectrum measure
- **Antenna on top of the tank is a good configuration**

Power detector measurement

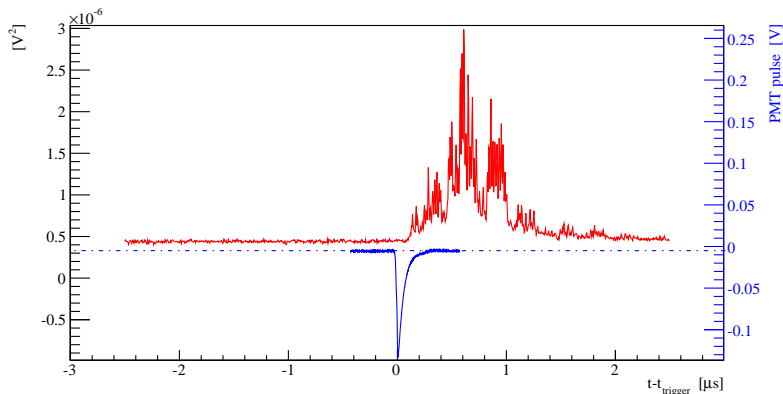

- Averaged traces
- Same response obtained without the Power Detector
- Same observables considered to estimate the noise

Results on noise from PMTs

Without the Power Detector:

position	signal	E [$\mu\text{V}/\text{m}$]	P [dBm]
top of tank	baseline	52.80	-49.02
top of tank	1 μs maximum	53.72	-48.87
top of tank	100 ns maximum	54.08	-48.81

With the Power Detector

position	signal quantity	E [$\mu\text{V}/\text{m}$]	P [dBm]
top of tank	baseline	54.39	-48.76
top of tank	1 μs maximum	55.67	-48.55
top of tank	100 ns maximum	56.14	-48.48

Noise from the PMTs for the 1 μs window: 0.19 dB
Noise from the PMTs for the 100 ns window: 0.28 dB

Sensitivity

- Distribution of the values of the average power measured in a chosen time window for 2000 traces
- The sensitivity is the variance of the distribution
- Two parameters computed for two different windows: $1 \mu\text{s}$ 100 ns
- Parameters computed before the trigger and around the maximum

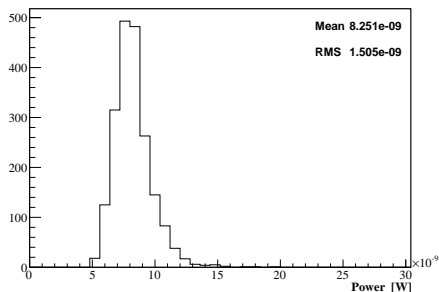

baseline: $\sigma_{1 \mu\text{s}} = 1.50 \text{ nW}$

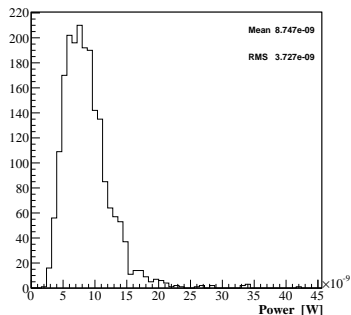

around maximum: $\sigma_{100 \text{ ns}} = 3.73 \text{ nW}$

Summary of noise measurements in the VHF band

- Test of the acquisition chain
- Measurements of noise coming from the tank
- **The best configuration for EASIER is the antenna on top of the tank**

Noise from the PMTs for the $1 \mu\text{s}$ window: 0.19 dB
Noise from the PMTs for the 100 ns window: 0.28 dB

- Sensitivity

Measurement	σ_W [nW]	σ_E [$\mu\text{V}/\text{M}$]
$1 \mu\text{s}$ baseline	1.50	4.95
100 ns baseline	3.61	11.97
$1 \mu\text{s}$ peak	1.71	5.55
100 ns peak	3.73	11.96

Expected trigger rate

Event number expected in the Vieira hexagon:

- SD events from May to August 2010
- Quality cut: T5
- Corresponding electric field higher than sensitivity

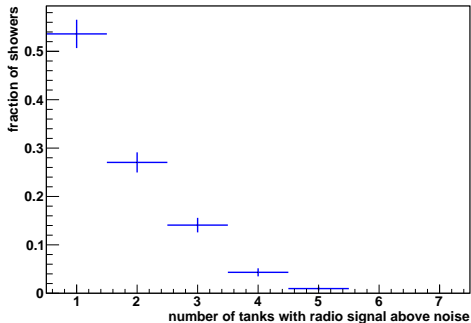
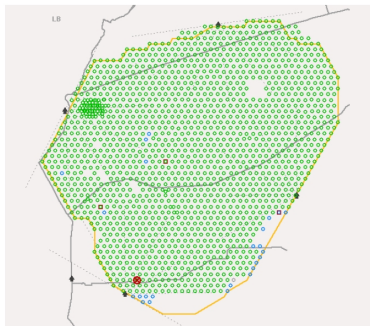

5 events/day in our hexagon

Stage of the VHF

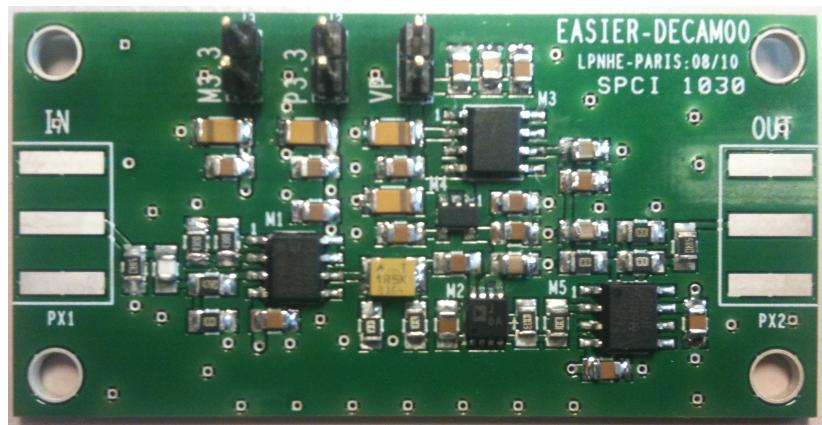

**Board with all the components just arrived in Paris!
Ready to complete the tests of the acquisition chain with the
Auger UB**

C+K band: spiral and horn antenna



Emission mechanism: **Molecular Bremsstrahlung Radiation**

- Isotropic radiation
- Observed in laboratory at accelerator experiment
- Never observed in field
- Process not completely understood
- Main experiments: AMBER, MIDAS, CROME

Again the slave trigger helps improving problem of detectability due to signal to noise ratio

Signal calculation

Scaling of the accelerator data from the Gorham paper taking into account the shower development and antenna FOV. Expected intensity:

- Coherent emission $I \propto N_e^2$
- Uncoherent emission $I \propto N_e$

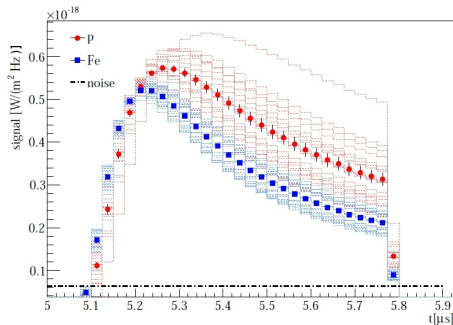
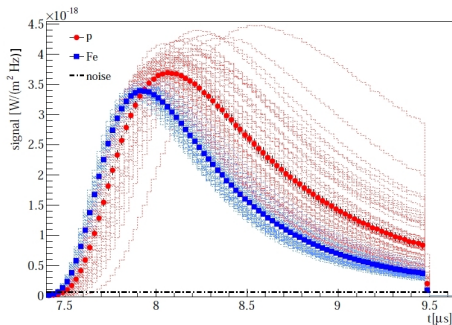

Traces expected at 900 m, for $\theta = 38^\circ$

Expected signal

Starting point: Gorham et al. "Observation of microwave continuum emission from air shower plasmas", Phys.Rev.D78,2008.

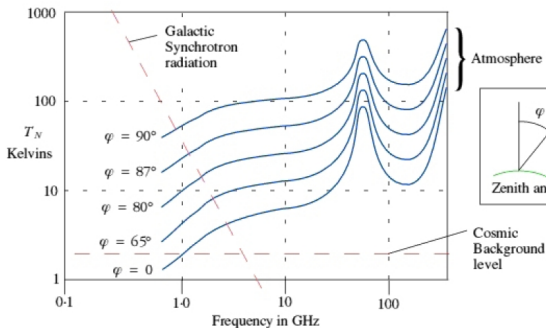

$$S(1000)_{Ne} \simeq -170 \text{ dBm}$$
$$S(1000)_{Ne^2} \simeq -155 \text{ dBm}$$

$$A\Omega \propto \lambda^2:$$

$$\Omega \sim \pi, \lambda \simeq 15 \text{ cm}, A \simeq 0.007 \text{ m}^2$$

$$B = 1 \text{ GHz}, \Delta t = 25 \text{ ns},$$

$$T = 10 \text{ K}$$

$$\Rightarrow \Delta I \simeq -174 \text{ dBm}$$

the signal rescaled is above the thermal noise!

Validate the acquisition chain:

- Choice of the antenna
- Antenna FOV
- Antenna gain
- System temperature
- Acquisition chain
- Background noise

Experimental setup

- Spiral antenna
- Commercial horn antenna (same as MIDAS without dish)
- Low noise cables
- Spectrum analyzer



Model: DMX241

Digital Ready Expanded C Band LNBF



Input Frequency:	3.4-4.2GHz
Output Frequency:	950-1750MHz
Noise Figure:	13K
Gain:	70dB
Polarity:	1 (Hor or Ver)
LO Frequency:	5150MHz
Image Rejection	45dB Min

Switch Voltage

Vertical:	14V DC
Horizontal:	18V DC
Output Impedance:	75Ohms
Output Connector:	F-Female

Private
Label
Available

Super High
Gain of
70dB

WS International Global Satellite Distribution

1200 Cobb Parkway North ~ Suite 100B ~ Marietta, GA 30062-2418 USA
Tel: +770 420 5272 ~ Fax: +770 420 5350
Email: sales@wsidigital.com ~ Web: www.wsidigital.com

Measures with the spiral

Measurements taken in Argentina to study the environmental noise:

- Spiral antenna
- Two LNA: $G = 38$ dB, $N = 2$ dB, $B = 2 - 9$ GHz

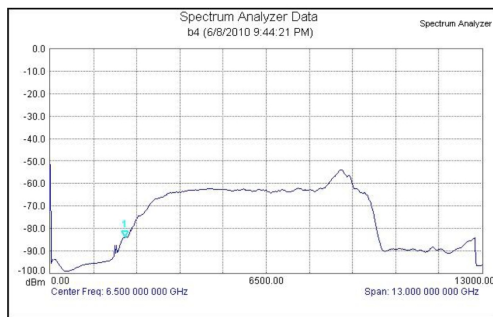

Clean band: 3-7 GHz

Thermal noise dominated by the LNA noise

Measures with the horn



Measurements taken in Paris:

- Horn antenna
- Integrated LNB

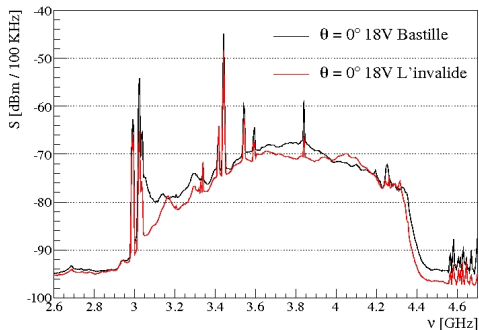

Horn characterization: gain and temperature

Preliminary characterization:

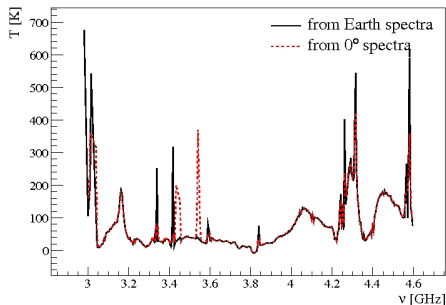
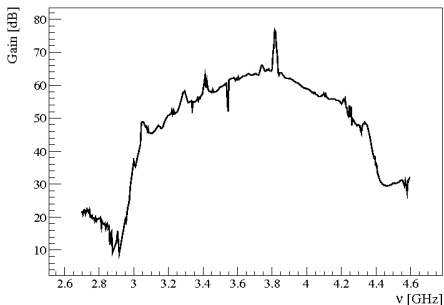

- $P = k_B \cdot T \cdot \delta\nu \cdot G$
- $T_{ground} = 300 \text{ K}$, $T_{sky} = 10 \text{ K}$
- System temperature computed inverting the equation: $T \sim 20 \text{ K}$

Summary of the C+K

- Signal calculation from Gorham paper
- Two antennas tested: spiral and horn
- Horn antenna seems more promising
- Background measurements in Argentina
- Preliminary characterization of the horn antenna

⇒ **work in progress**

Study of the universality to recover the muonic signal from the electromagnetic signal detected by EASIER

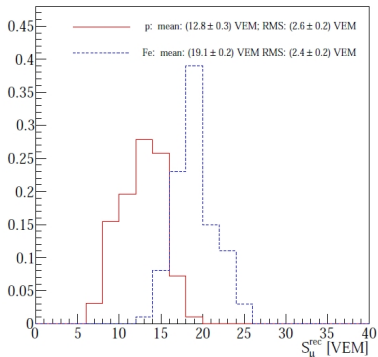

S_{μ} by subtraction of the S_{em} measured by EASIER

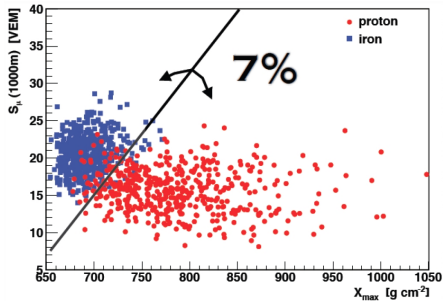

Anti-correlation between X_{max} and S_{μ} from simulated showers

Conclusions and future plans

VHF band

Done:

- Antenna chosen and tested
- Acquisition chain partially tested
- Noise from the tank evaluated
- Expected trigger rate computed

To do:

- Test of the complete acquisition chain

First deployment foreseen in november

C+K band

Done:

- Different types of antenna tested
- Signal and noise calculation

To do:

- Choice of the antenna
- Evaluation of the system temperature
- Take into account the antenna response in simulations

First deployment foreseen in december