



CMS

INFN  
ROMA  
Istituto Nazionale di Fisica Nucleare  
Sezione di Roma

# CMS Status Report

Sept. 1st, 2021 - 147th LHCC Meeting Open Session

*Livia Soffi on behalf of CMS*



# Outline

Long shutdown 2 activities  
aiming at Run 3

Computing operations and  
data processing

Physics analyses and publications

Phase 2 progress





# *Long shutdown 2 progress towards Run 3*



# CMS operations during the pandemic

- **Shift Leader and Technical Shifter** in the control room fulfilling safety rules
- DAQ, Trigger, and DQM shifter operating remotely
- Subdetector experts in PT5 only if needed



- Waiting for second elevator replacement before restarting public **underground visits on Oct 4 2021** at the earliest



# Focus on Pixel installation



- Pixel refurbishment completed: New Layer 1, DCDC converters, module exchange

6/2



# Focus on Pixel installation

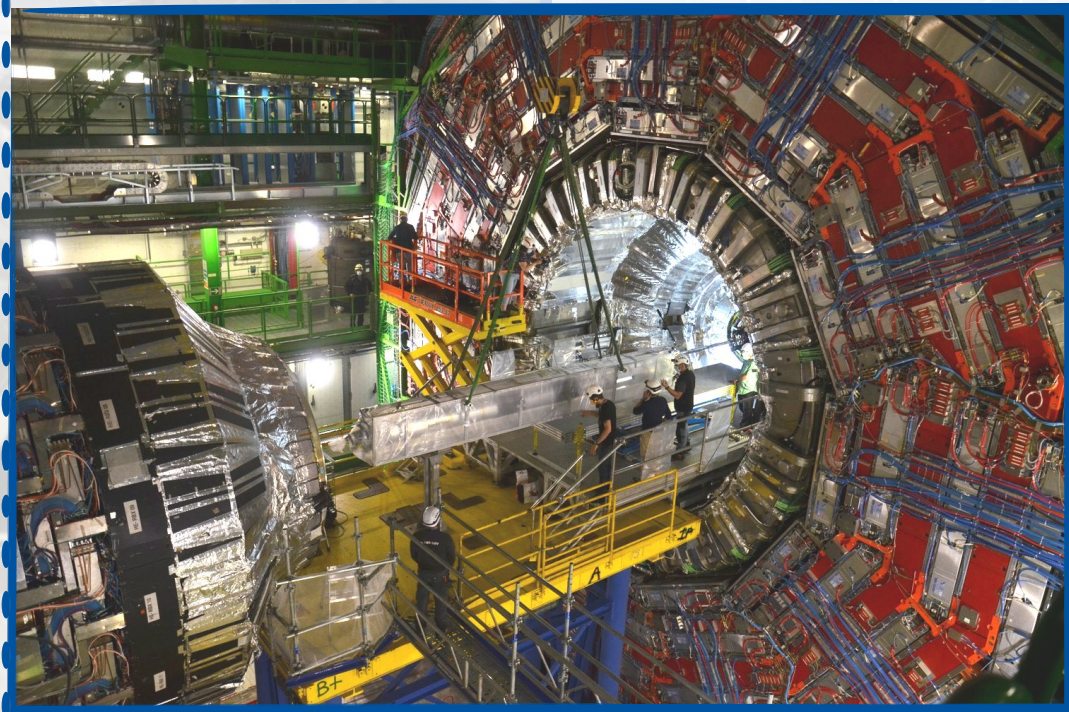

Lowering BPix onto installation platform and insertion

Pixel refurbishment completed: New Layer 1, DCDC converters module exchange

6/2

6/21



# Focus on Pixel installation

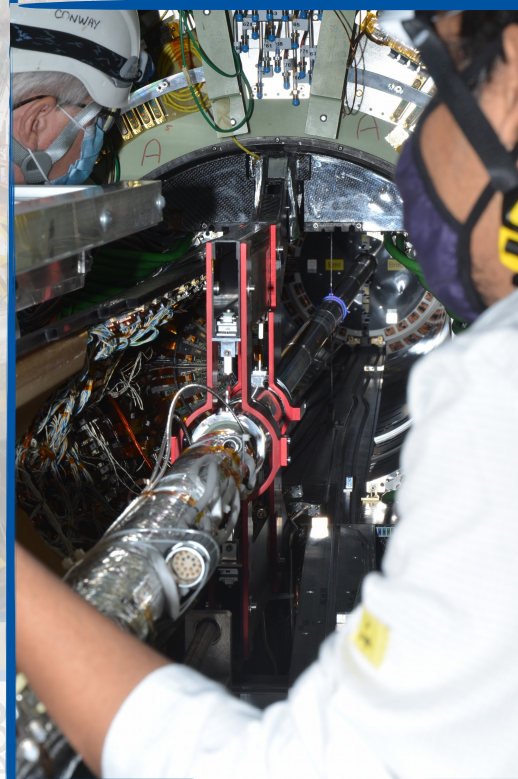

Lowering Bmi  
Pixel refurbishment  
platform and insertion  
completed: New  
Layer 1, DCDC  
converters module  
exchange

FPix installation and CERN Live Event

6/2

6/21

6/29



# Focus on Pixel installation

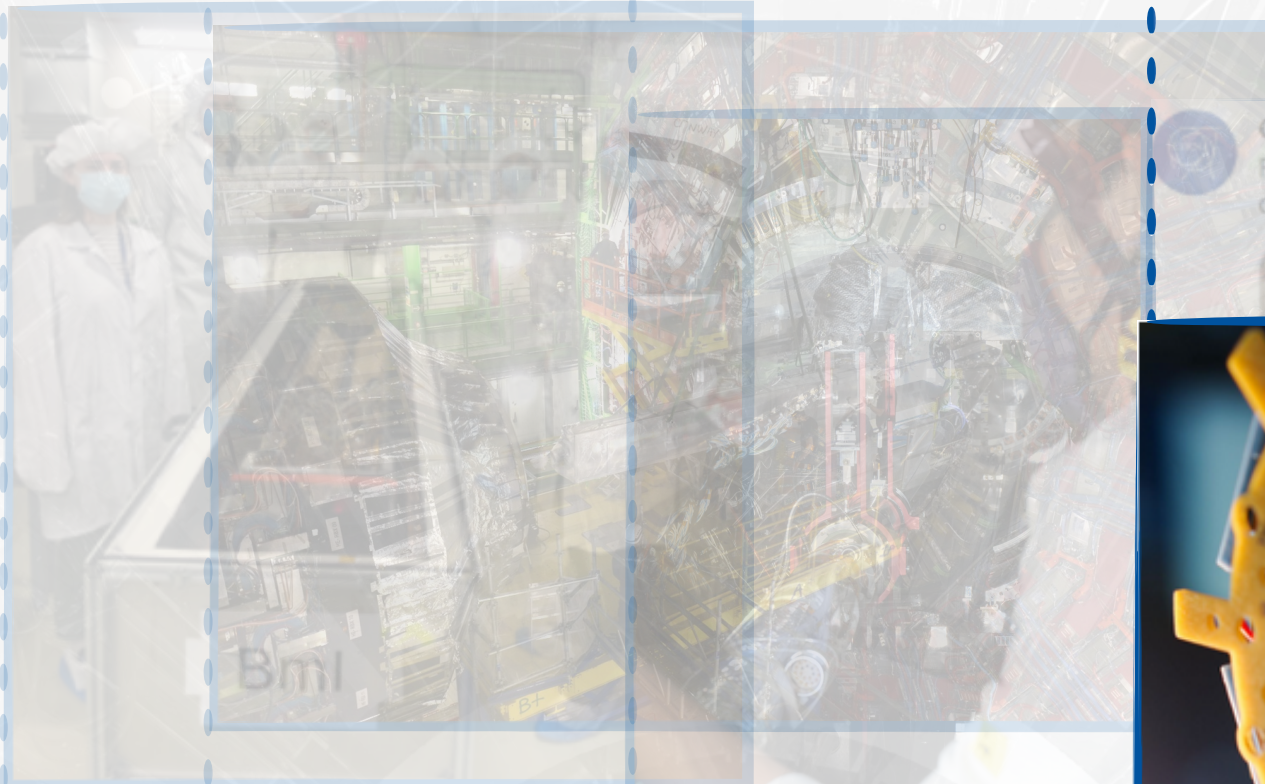

Pixel refurbishment completed: New Layer 1, DCDC converters module exchange

Lowering BPix onto installation platform and insertion

FPix installation

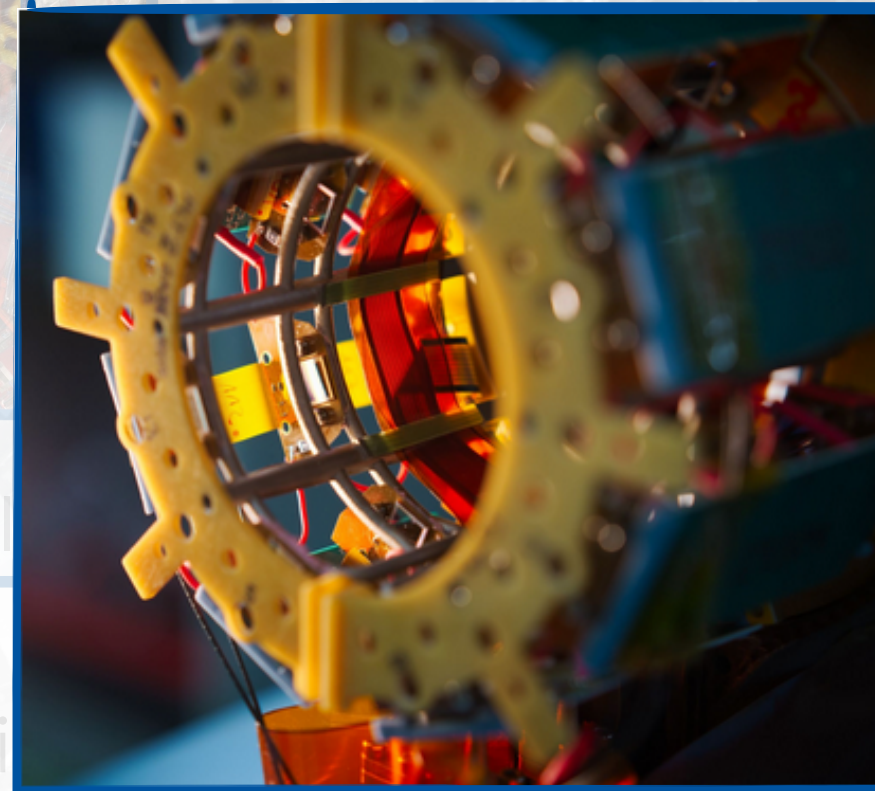

PLT/BCM installation

6/2

6/21

6/29

7/5



# Focus on Pixel installation



Pixel refurbishment completed: New Layer 1, DCDC converters module exchange

6/2

6/21



Lowering BPix onto installation platform and insertion

6/29

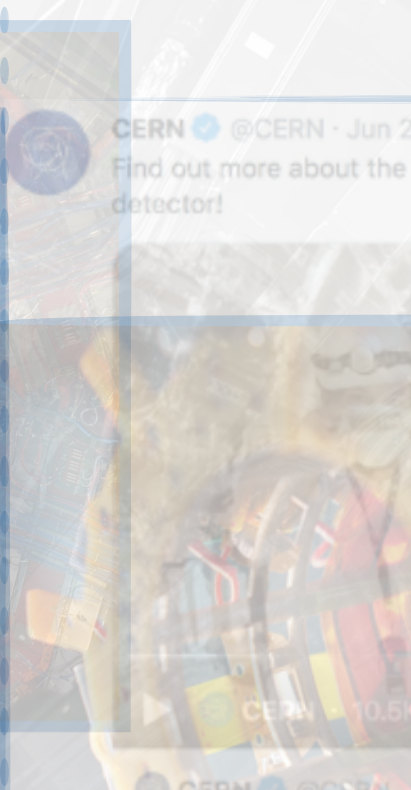

FPix installation and CER

7/5

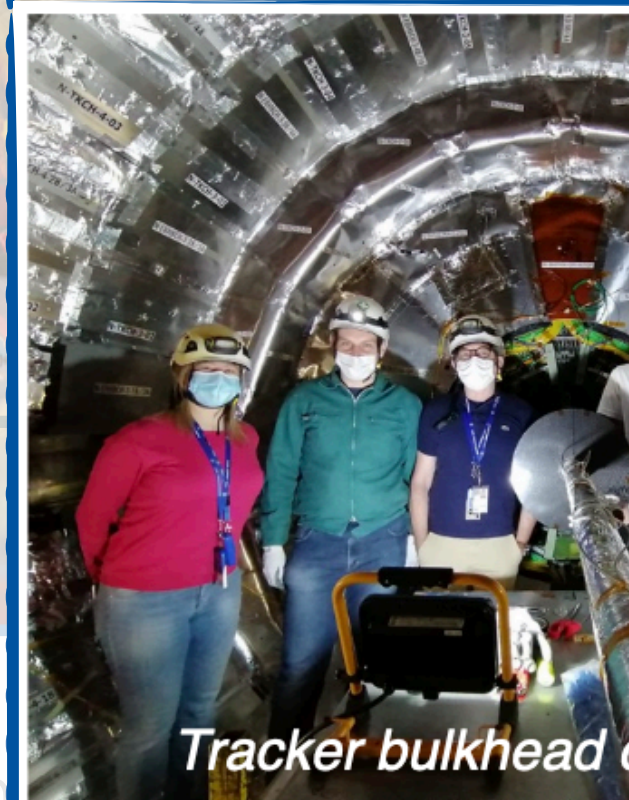
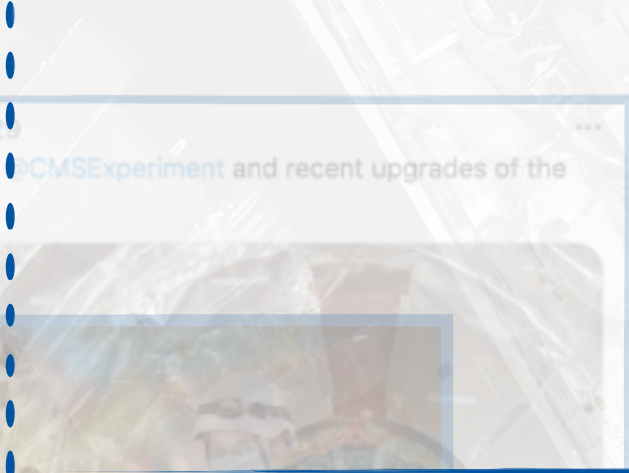

PLT/BCM in

7/10



Tracker bulkhead closing team

Tracker bulkheads closed



# Focus on Pixel installation

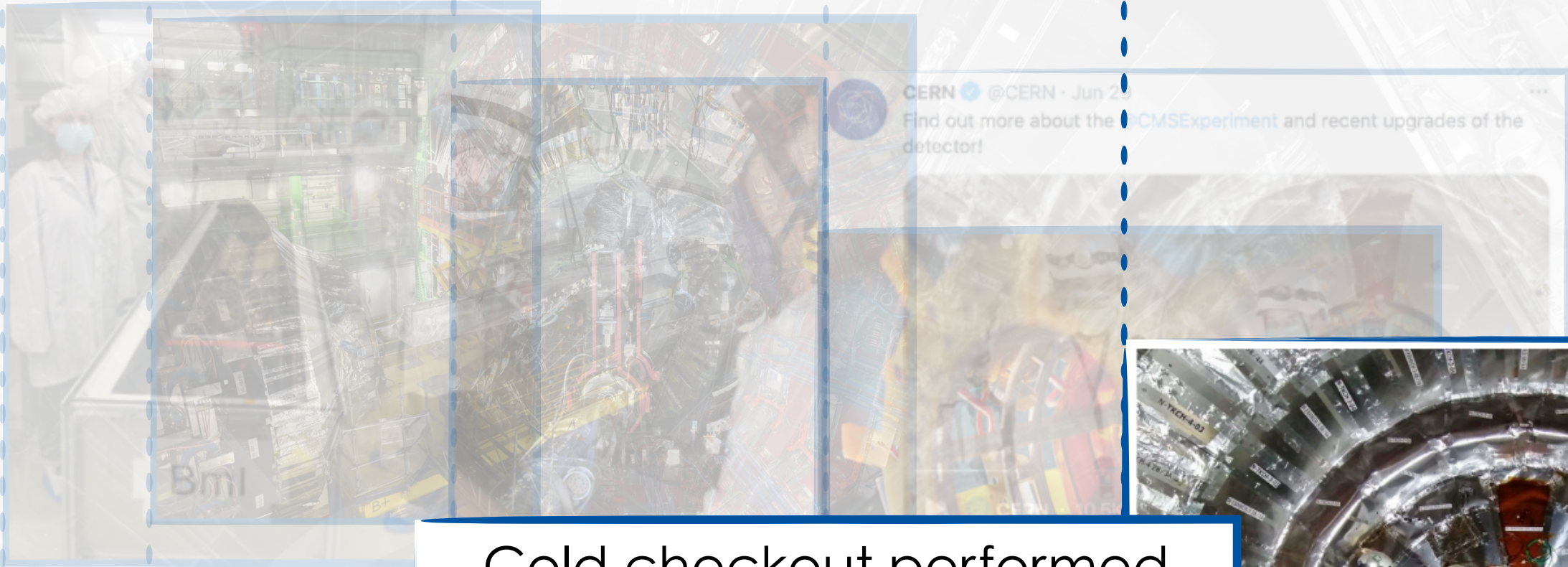

Cold checkout performed successfully at -22C

Pixel refurbishment completed: New Layer 1, DCDC converters module exchange

FPix installation and CER

PLT/BCM in



Tracker bulkhead closing team

Tracker bulkheads closed

6/2

6/21

6/29

7/5

7/10



# Beam Radiation Instrumentation & Luminosity (BRIL)

Many Run 2 systems upgraded with new components

- **Trigger  $\mu$ -scouting luminosity** (L1 muons)

New: Phase-2 BRIL firmware

- **REMUS, LHC RadMon**

New: more radiation monitors

- **BCML2** beam loss

New: sapphire & pCVD diamond sensors

- **Beam Halo Monitor**

New: XDAQ software

- **BPTX (~175 m) Timing/trigger**

New: oscilloscope upgrade

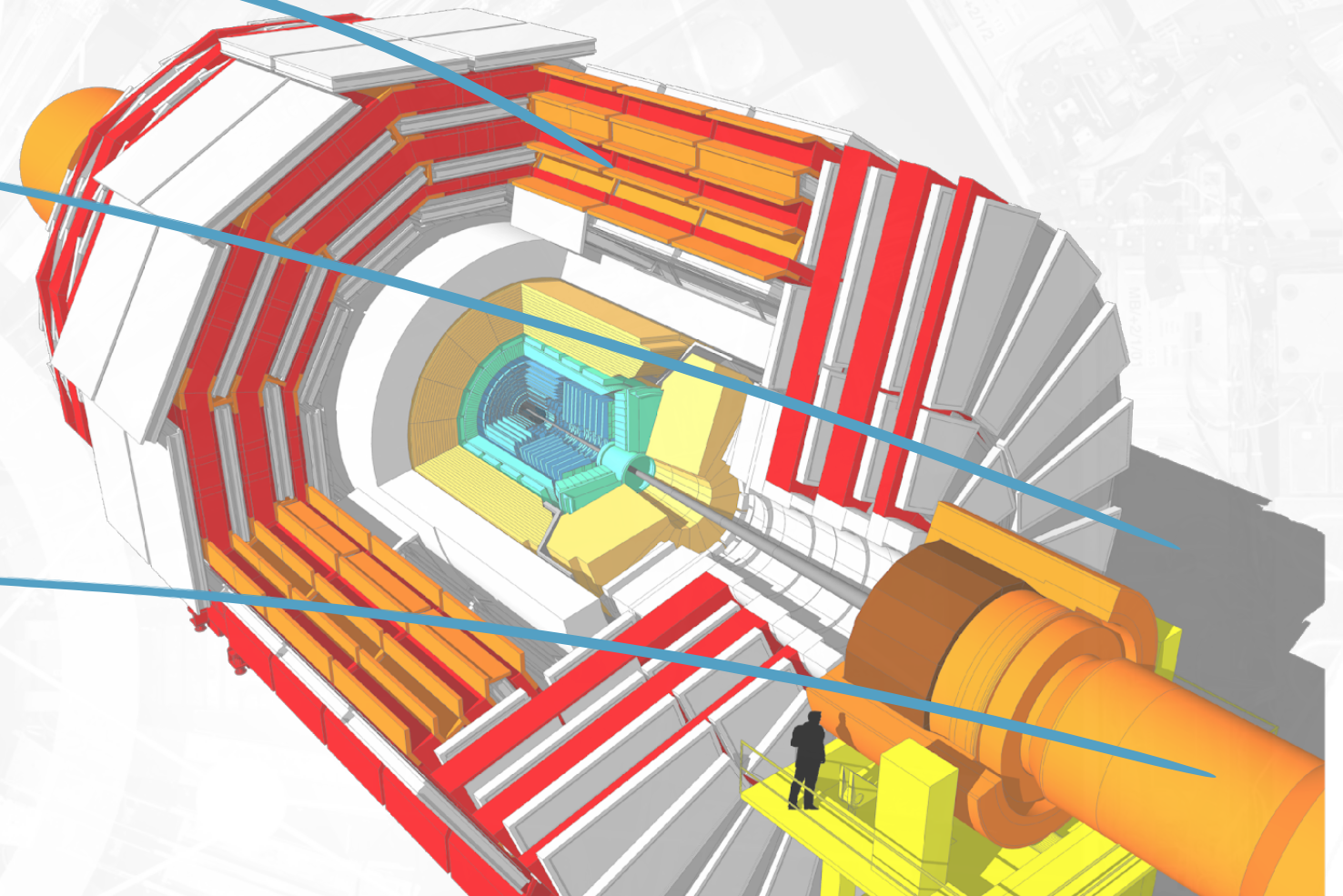



# Beam Radiation Instrumentation & Luminosity (BRIL)

Completely rebuilt and optimised for Run 3

Many Run 2 systems upgraded with new components

- **Trigger  $\mu$ -scouting luminosity** (L1 muons)

New: Phase-2 BRIL firmware

- **REMUS, LHC RadMon**

New: more radiation monitors

- **BCML2** beam loss

New: sapphire & pCVD diamond sensors

- **Beam Halo Monitor**

New: XDAQ software

- **BPTX (~175 m) Timing/trigger**

New: oscilloscope upgrade

- **BCM1F** luminosity, beam-induced background

- **BCML1** beam loss

- **Pixel Luminosity Telescope** luminosity



1st w July



# Beam Radiation Instrumentation & Luminosity (BRIL)

Completely rebuilt and optimised for Run 3

Many Run 2 systems upgraded with new components

- **Trigger  $\mu$ -scouting luminosity** (L1 muons)

New: Phase-2 BRIL firmware

- **REMUS, LHC RadMon**

New: more radiation monitors

- **BCML2** beam loss

New: sapphire & pCVD diamond sensors

- **Beam Halo Monitor**

New: XDAQ software

- **BPTX (~175 m) Timing/trigger**

New: oscilloscope upgrade

- **BCM1F** luminosity, beam-induced background

- **BCML1** beam loss

- **Pixel Luminosity Telescope** luminosity



1st w July

- **All BRIL systems installed**, being commissioned to be **ready** for the October LHC beam test!



# Latest from Point 5

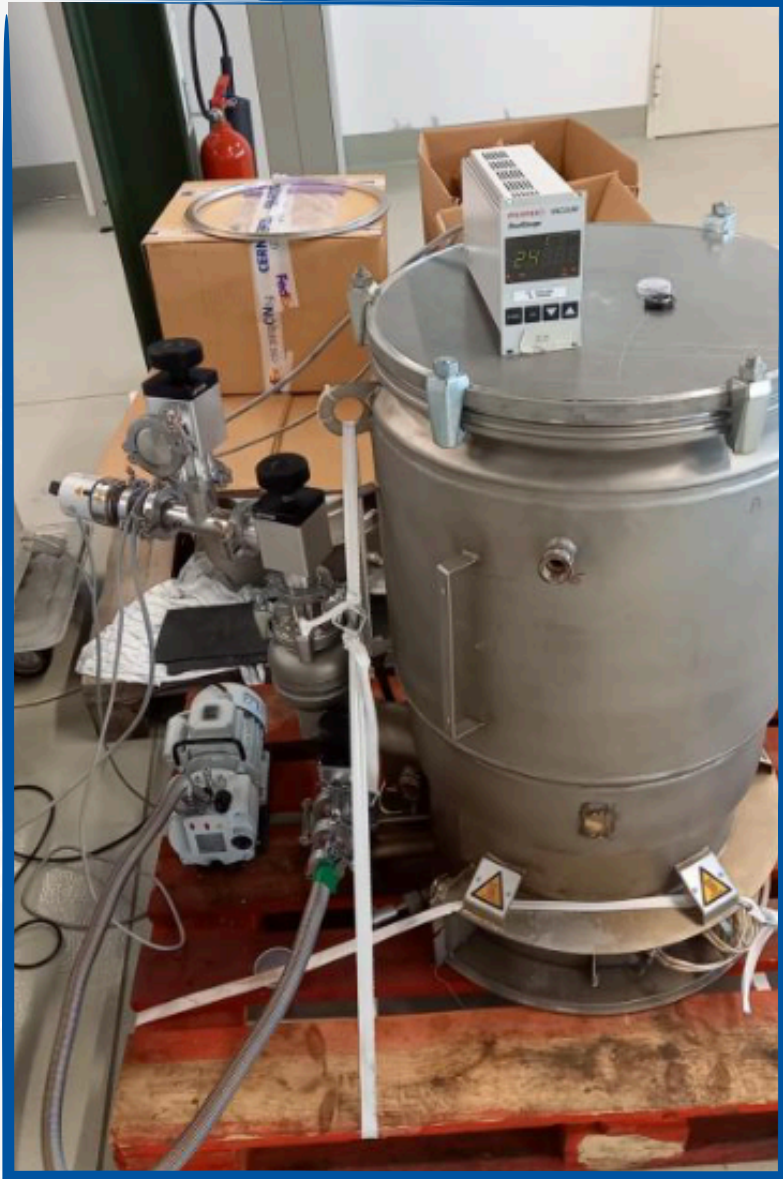

Start CMS closing operations

8/31

Magnet starts cooling down

8/23

New magnet diffusion  
vacuum pumps  
commissioned

8/17

- Ready for data taking by beginning of Oct.



# Summer 2021 data taking

- Extensive **cosmic data taking** performed during summer:

## Cosmic Run at Zero Tesla (CRUZET) and Cosmic Ray data at Four Tesla (CRAFT)

Crucial for CMS commissioning and used to **analyse, calibrate, and align detectors**

Month	June	July	Aug	Sept -)ct	Oct	Nov	Dec	Jan	Feb	Apr
Activity	MWGR	CRUZET	CRUZET	CRAFT	Beam Test	MWGR	MWGR	CRAFT	CRAFT + First beams	Ramp-up (coll.)
When?	June 9-11	Jul12...	...Aug14	Mid of Sept. to the Beam test .	Week 42- 43	Mid. of Nov	Mid. of Dec.	~from mid of Jan to the first beams	From Feb21st	Physics data
Data taking	Yes (~3 days)	Yes (24/7)	Yes (24/7)	Yes (24/7)	Yes (during the BT)	Yes (~3 days)	Yes (~3 days)	Yes (24/7)	Yes (24/7)	Yes (24/7)

- CRUZET started on **July 12th**: many centrally organized and local activities
- **CRAFT** to begin in early **October**, after magnet commissioning
- **All subsystems running without major problems.** Several tests ongoing to improve stability of the system.

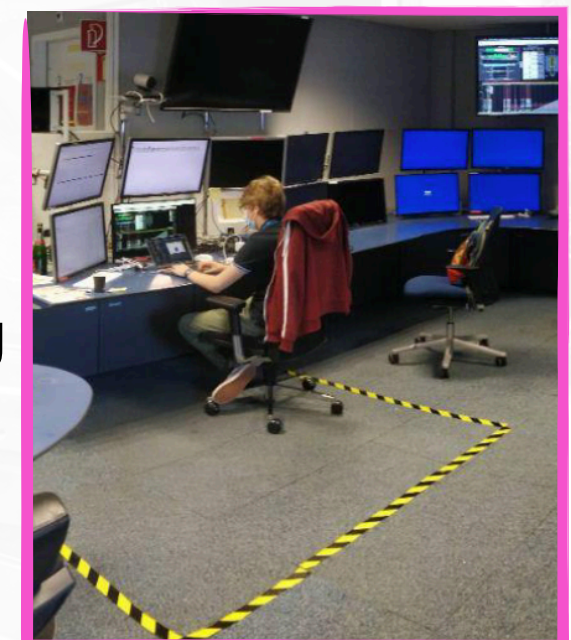



# CRUZET: Detector highlights

## Calorimeters

- **ECAL:** new features being tested extensively
  - Upgrade control and safety system
  - Improved algos for spikes rejections at L1
  - Corrosion issue found in preshower cooling system. Refurbishment campaign underway

## Muon Systems

- **GEM:** collect stats and commissioning
  - Replacement of 2 GE chambers in one endcap (VTRx baked to monitor RSSI drifts)
  - **Continuous monitoring** of chambers “not configuring” / “in error during run”
  - Good progress in the **GEM-Encap Muon Track Finder** L1 integration and commissioning

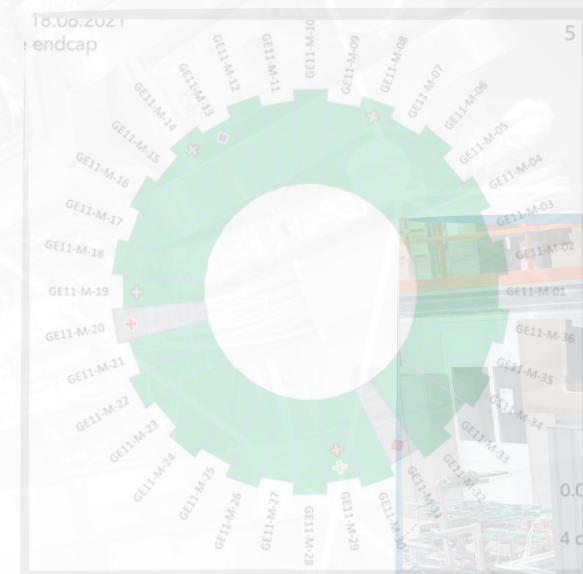



# CRUZET: Detector highlights

## Calorimeters

- **ECAL:** new features being tested extensively
  - Upgrade control and safety system
  - Improved algos for spikes rejections at L1
  - Corrosion issue found in preshower cooling system. Refurbishment campaign underway

## Muon Systems

- **GEM:** collect stats and commissioning
  - Replacement of 2 GE chambers in one endcap (VTRx baked to monitor **RSSI drifts**)
  - **Continuous monitoring** of chambers “not configuring” / “in error during run”
  - Good progress in the **GEM-Encap Muon Track Finder** L1 integration and commissioning

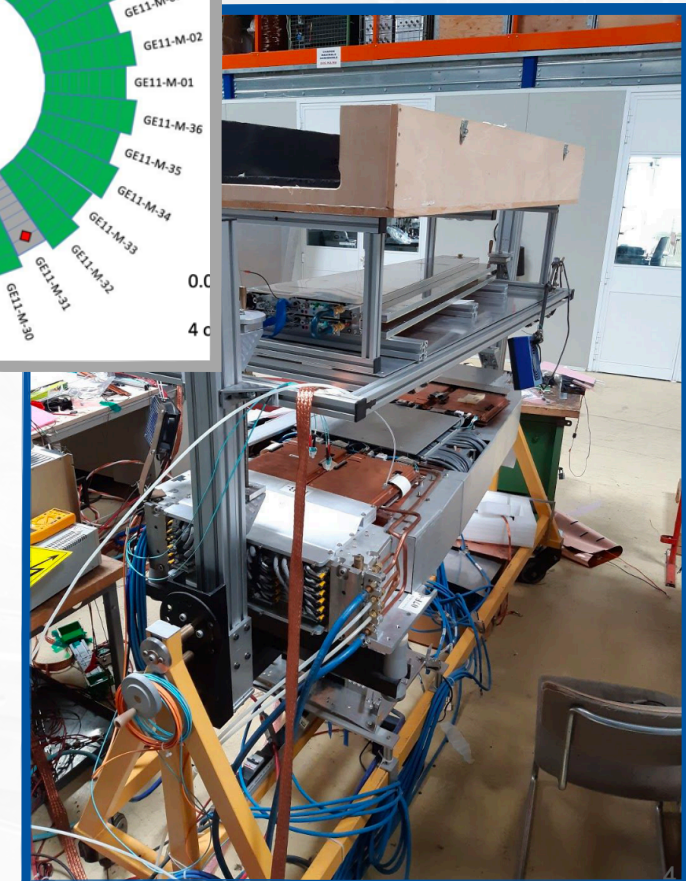
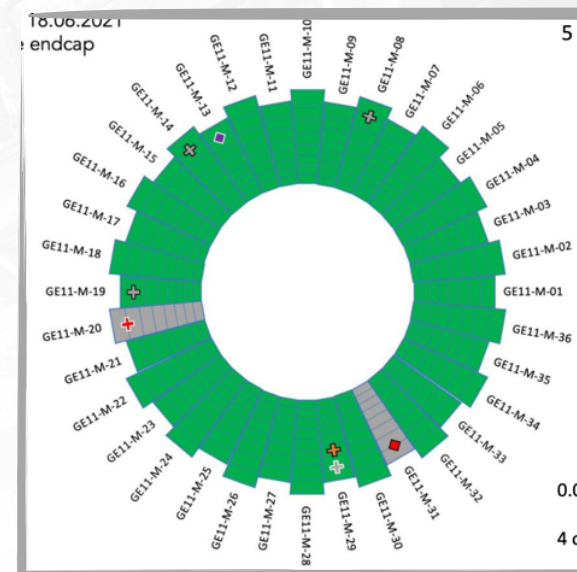



# CRUZET: Pixel alignment

- **Pixel working nicely after re-installation**
- BPix and FPix participated in global cosmic ray data-taking, **collecting 3.5 M events**
- Performed **initial track-based alignment**

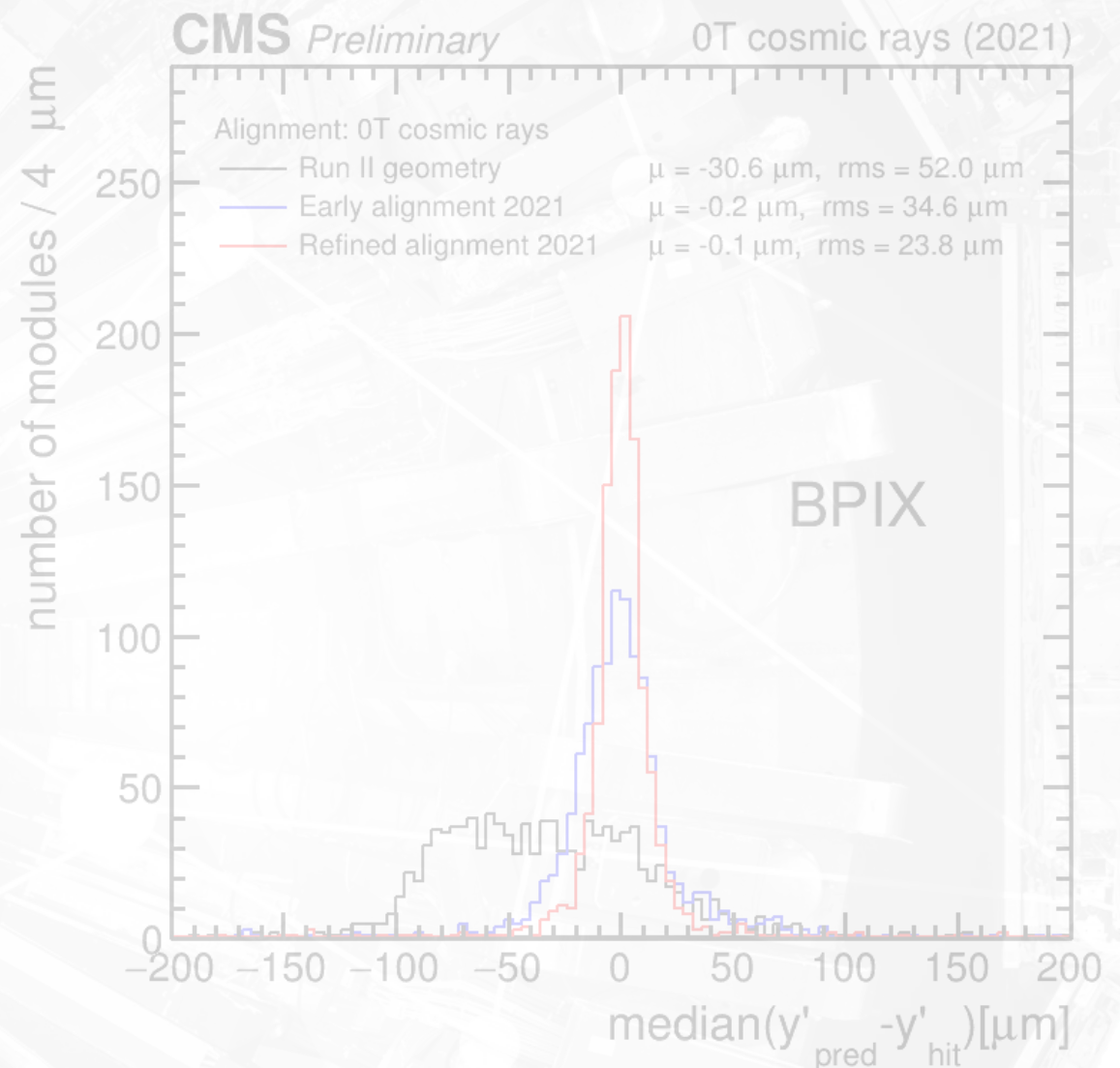
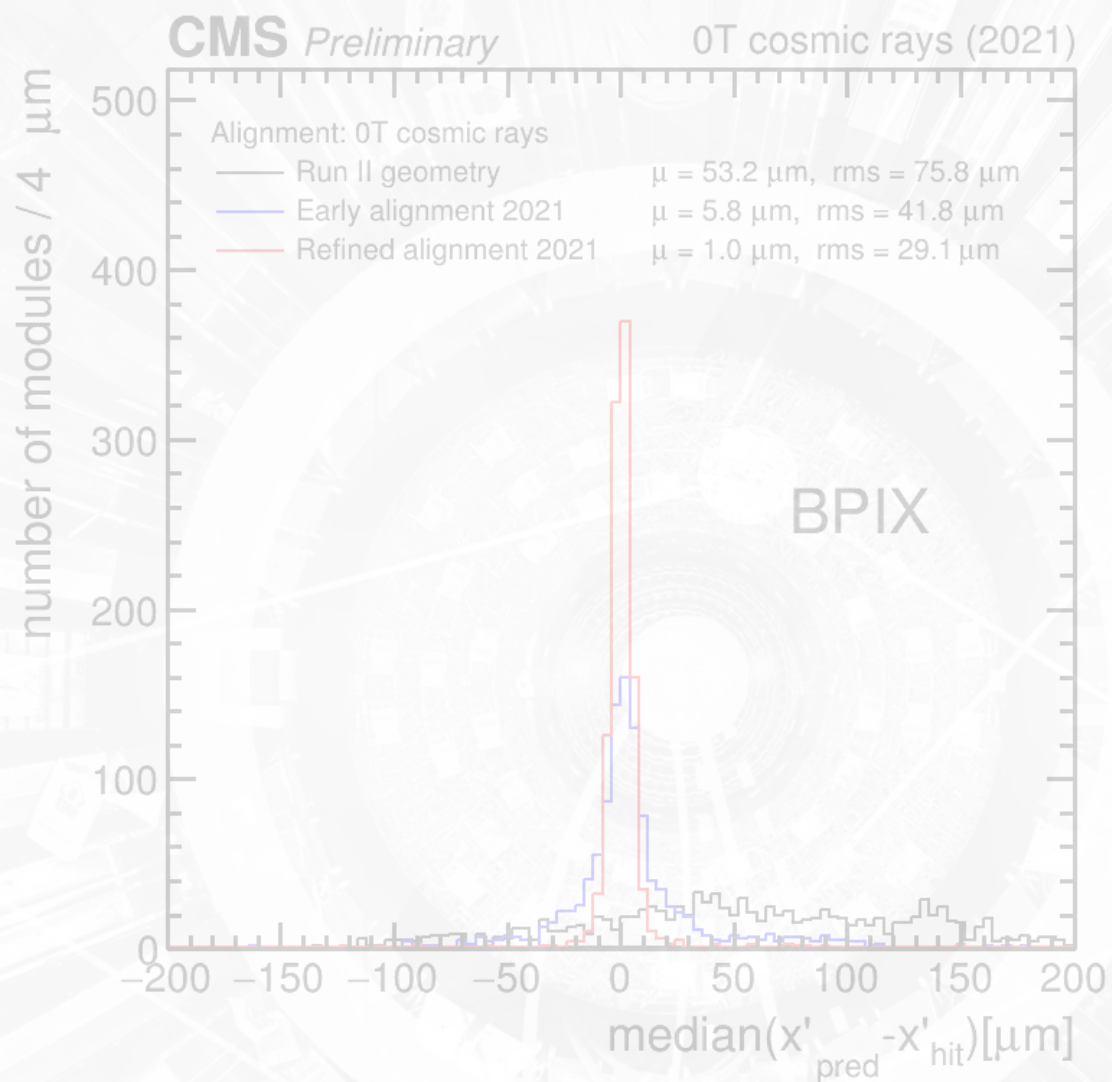



# CRUZET: Pixel alignment

- Pixel working nicely after re-installation
- BPix and FPix participated in global cosmic ray data-taking, **collecting 3.5 M events**
- Performed **initial track-based alignment**

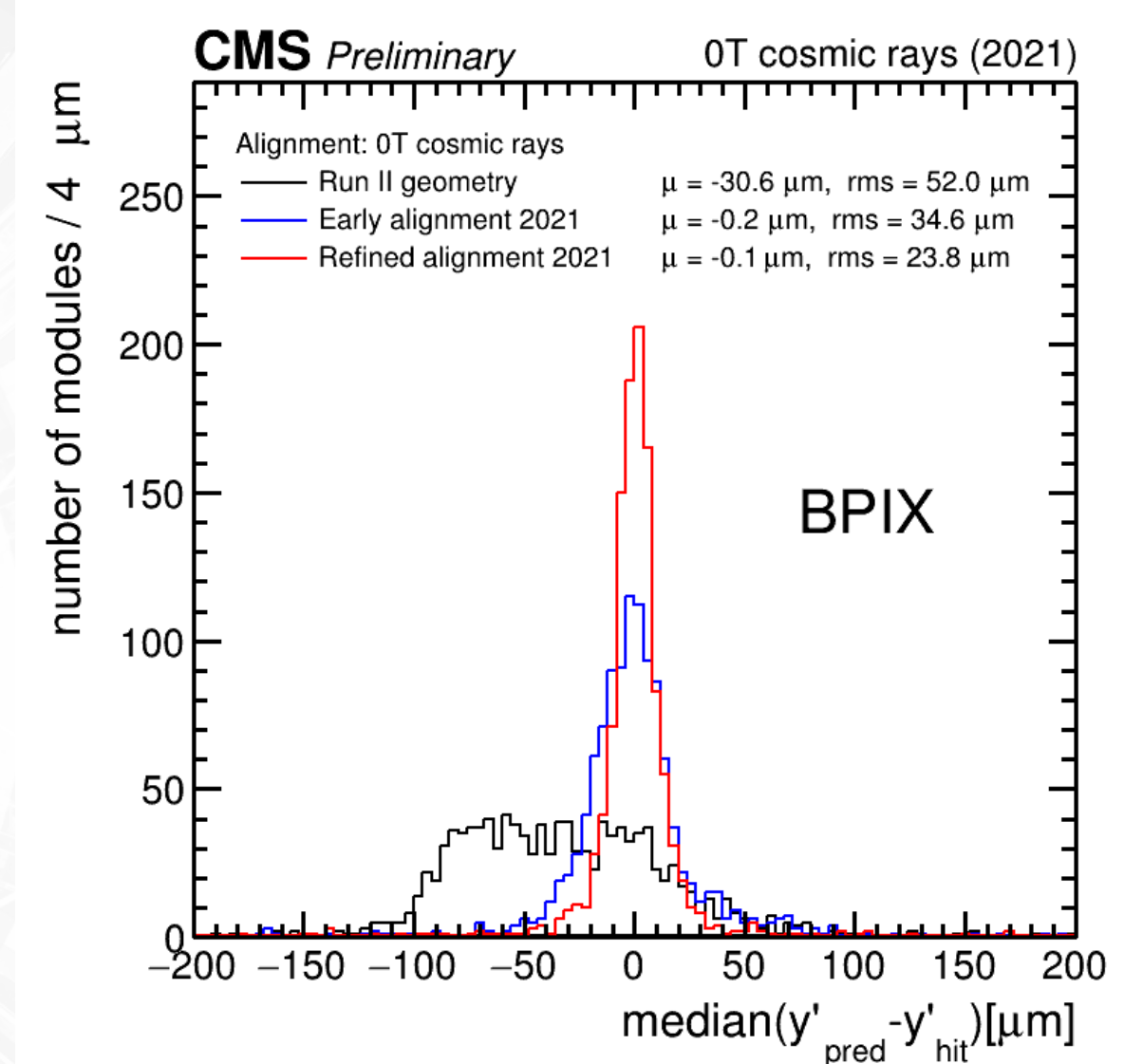
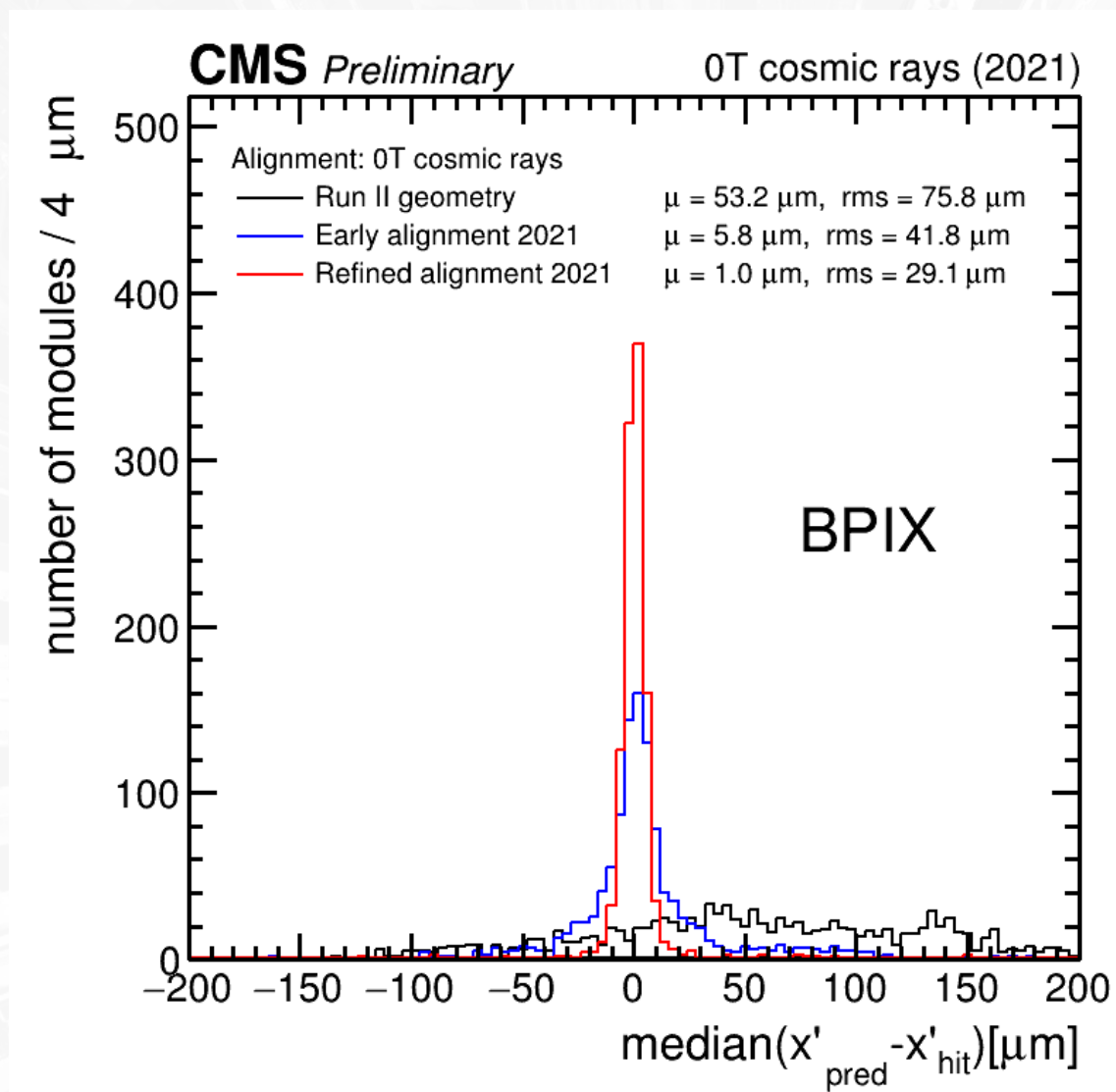



# GPU deployment @HLT

- Previously CMS has demonstrated **ECAL, HCAL and pixel local reco offloaded to GPUs** ( ~25-30% of the menu)
- Now **integrated necessary code to run GPU algorithms** in standard release
- **Completed the upgrade** of infrastructure to deploy GPU based menus at PT5

- currently two out of 153 nodes are equipped with an NVIDIA T4 GPU

- ability to run same config on CPU only and CPU+GPU nodes

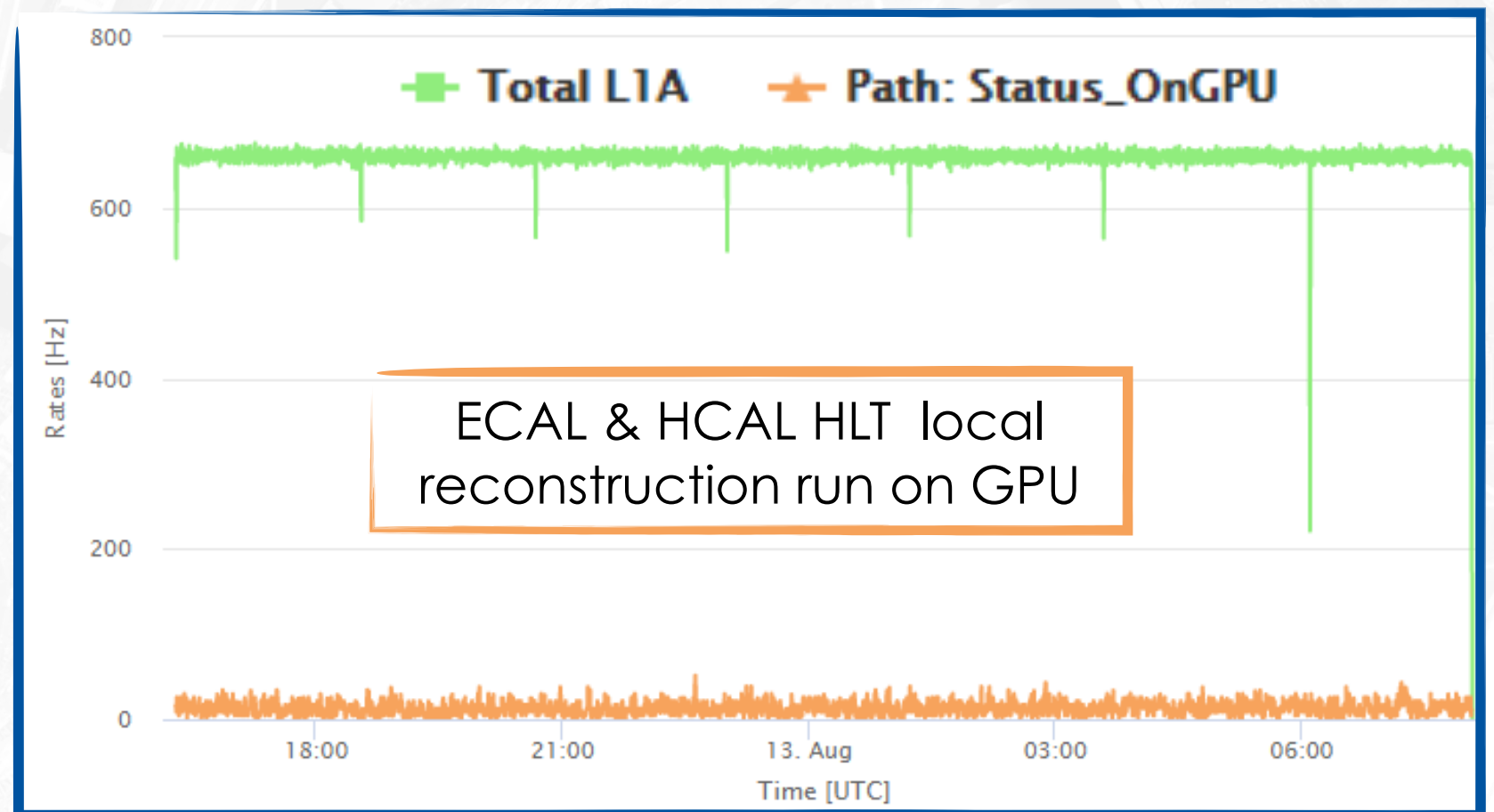

- System commissioned and GPU enabled menus **run routinely at PT5**



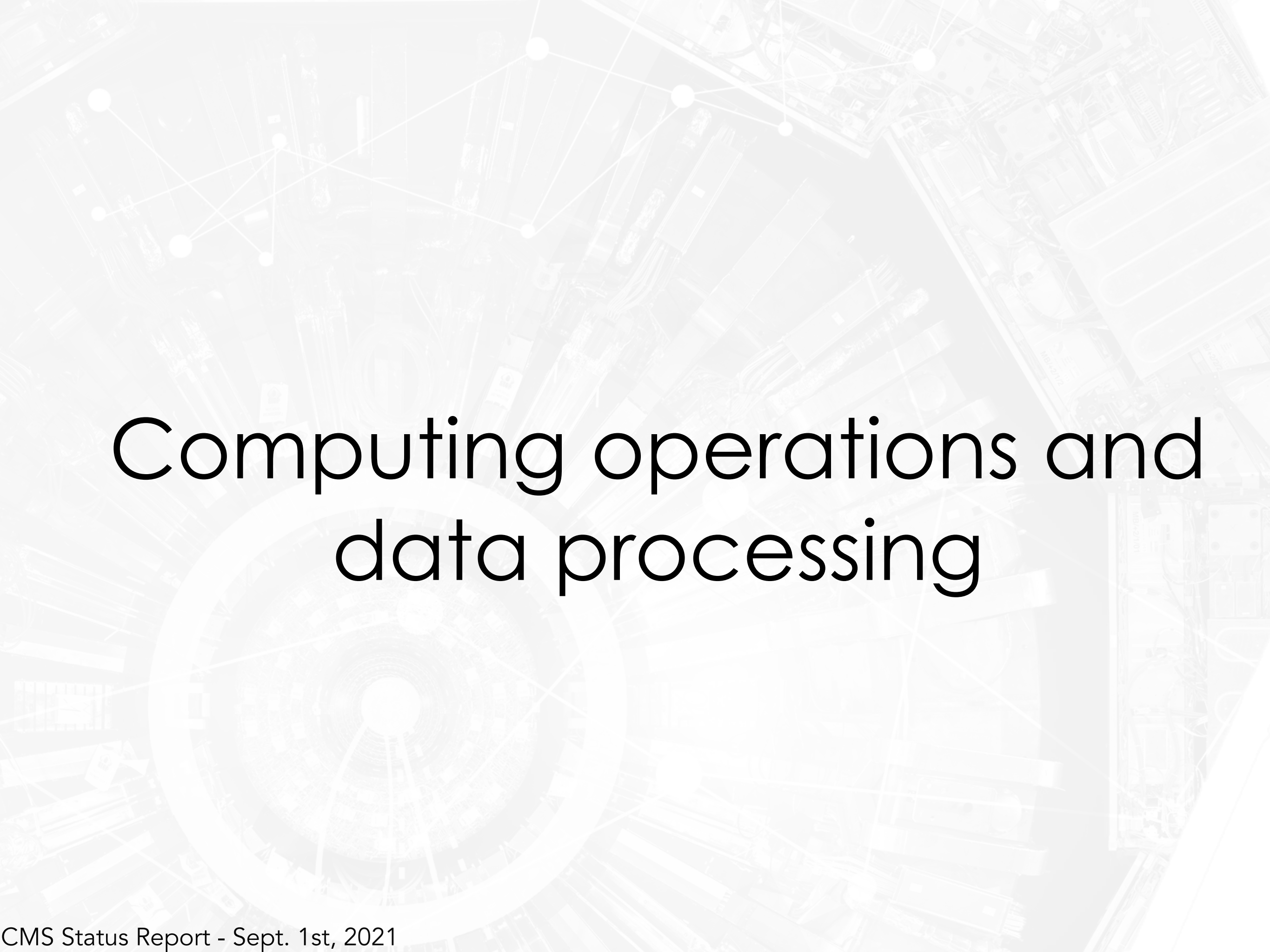

# Computing operations and data processing



# Release and production plan until mid 2022

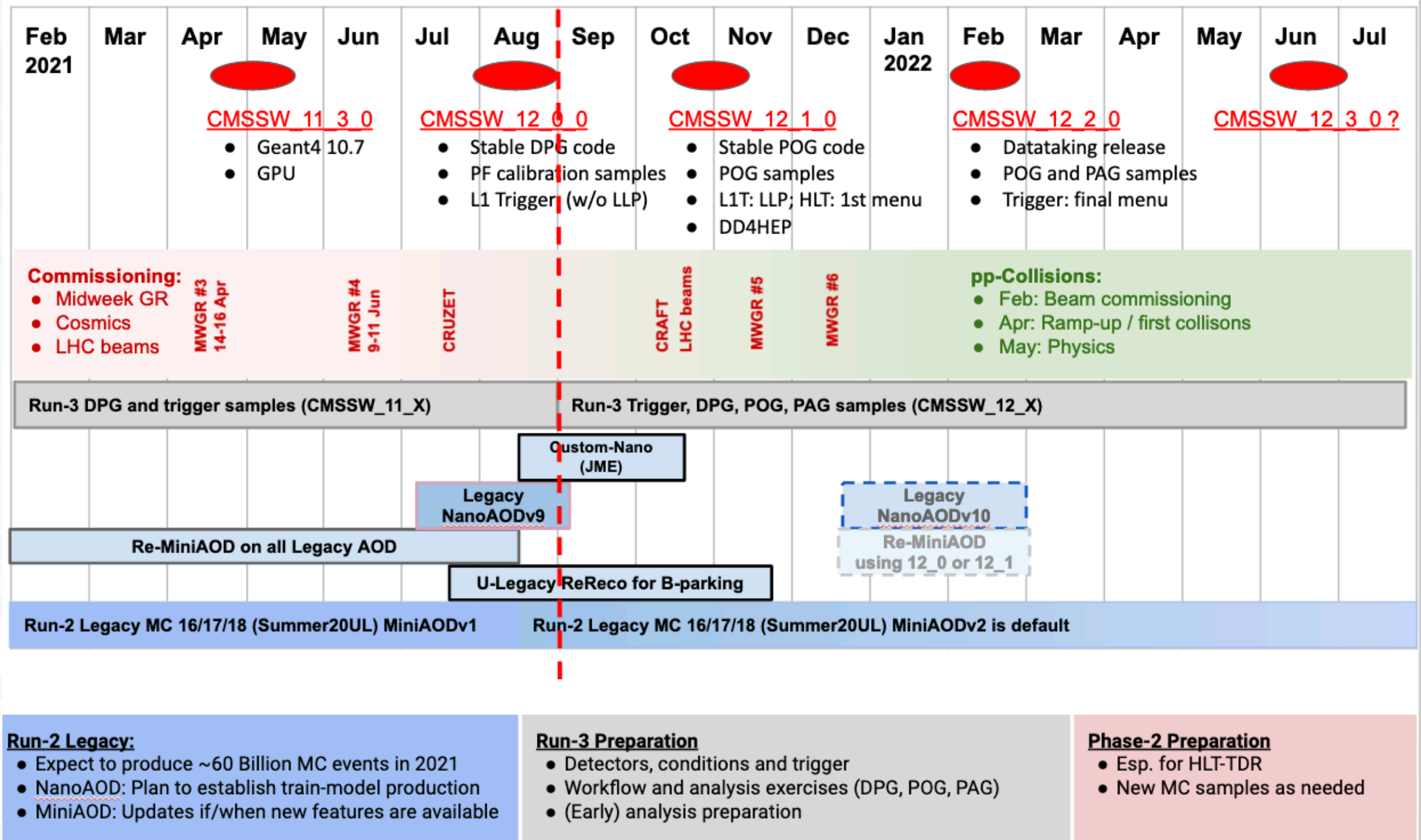

- CMSSW 12\_0\_0 is the first Python 3 only release



# Simulation and Re-Processing

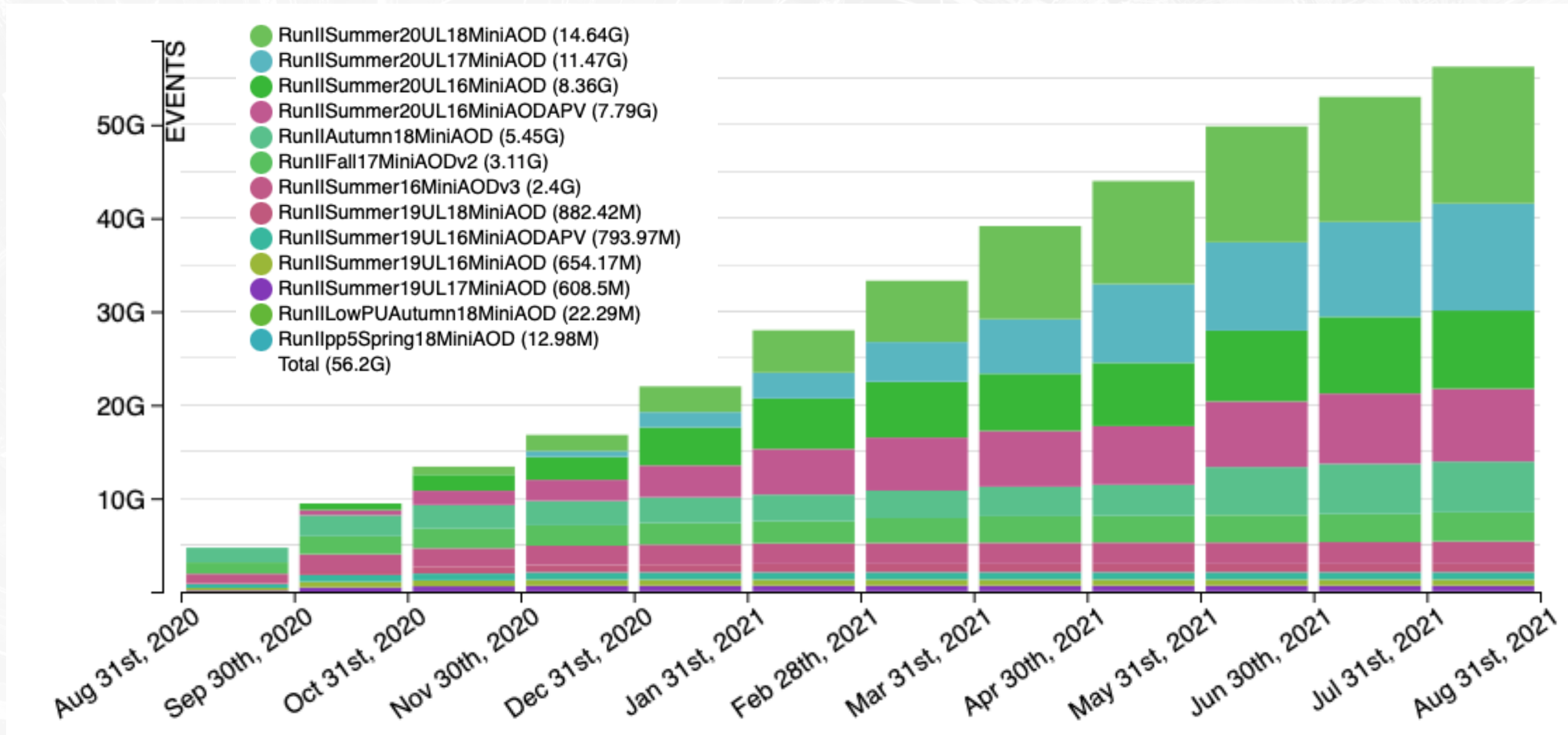

- **Simulation production:**  
**>50B unique Run II MC events** produced in past year



# Simulation and Re-Processing

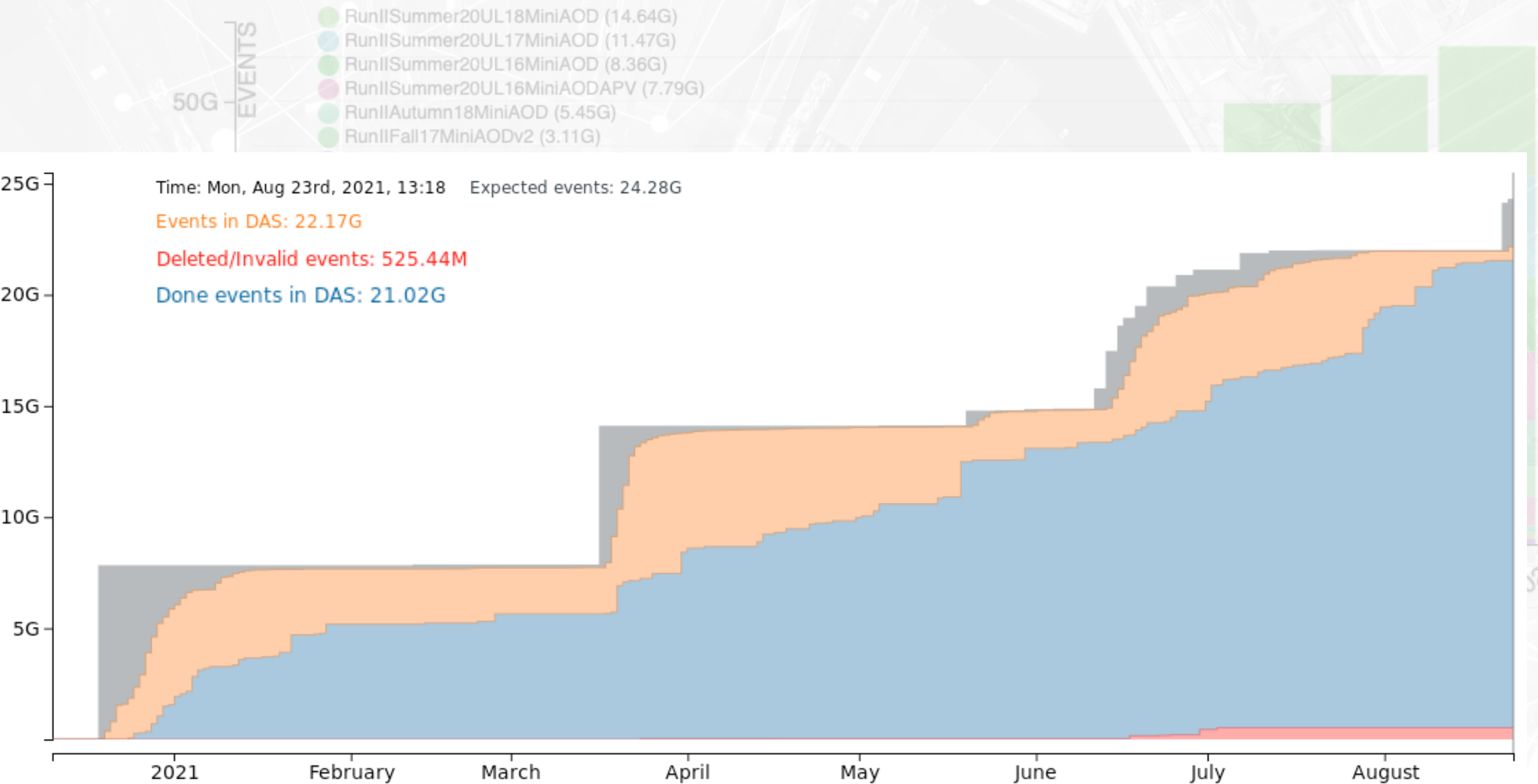

- **Analysis Run II data re-processing:** data nearly complete, MC 85%, B-parking recently submitted
- **Physics Object Group Run III** samples starting now



# High Performance Computing

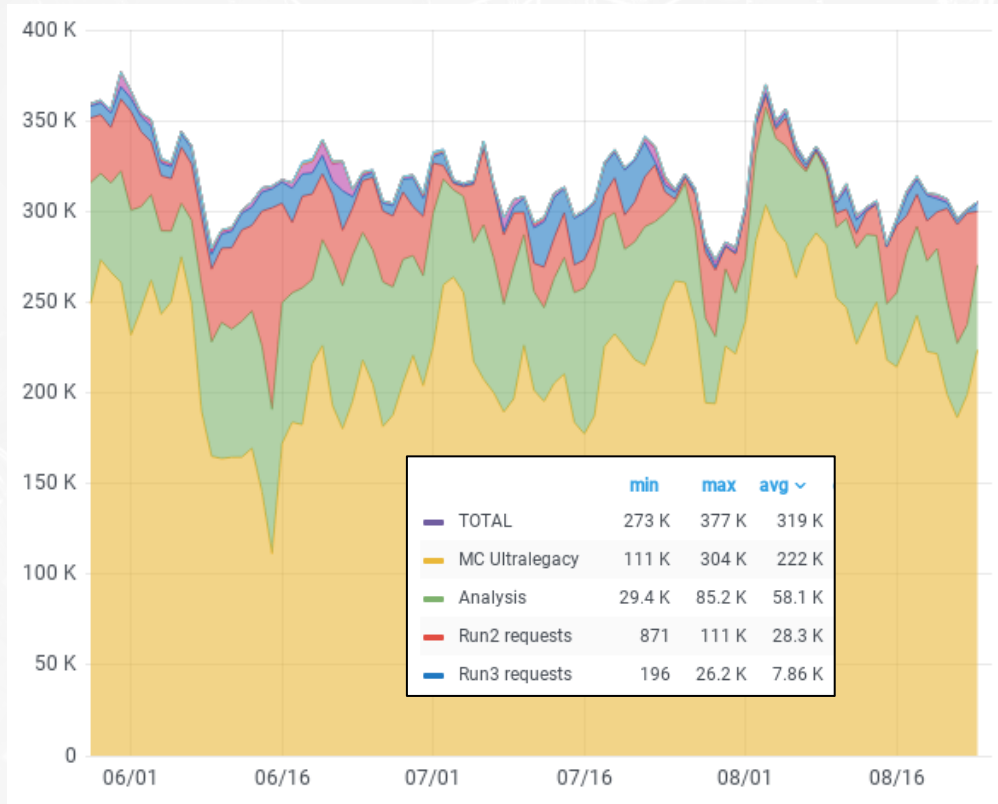

- Using full **CPU capacity** at disposal, **boosted by High Performance Computers**
- **Legacy Monte Carlo generation** dominating the job mixture

- Excellent usage of HPC, steadily increasing
- **HCP Average capacity tripled** in the first 7 months of 2021 relative to 2020

CMS HPC usage in '20 and '21: Number of Cores

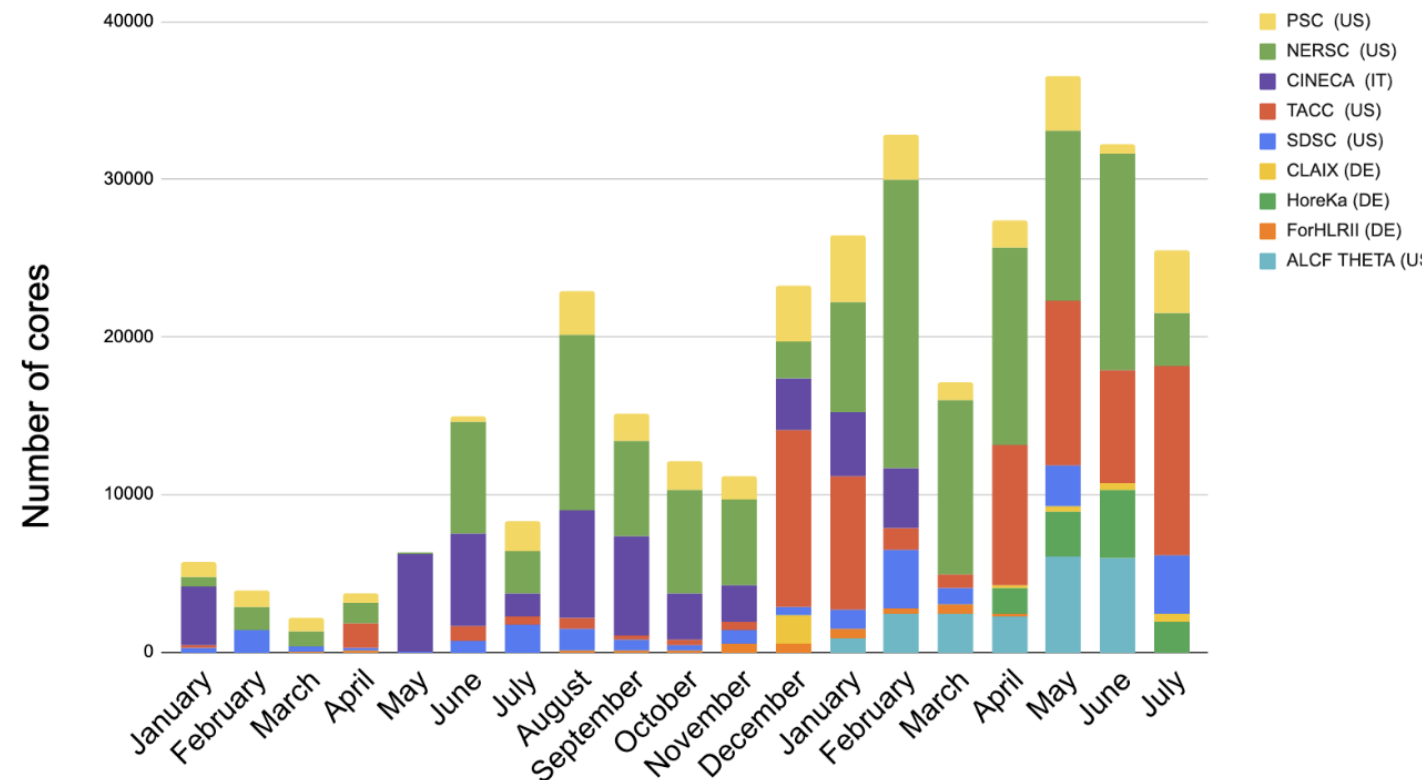





# *Physics analyses and publications*



# Major 2021 summer conferences

6/6



52 talks (plenary and parallel) - 25 posters - **15 New Results**

26/7



53 talks (plenary and parallel) - 35 posters - **26 New Results**

23/8



25 talks (plenary and parallel) - **4 New Results**



# Physics communications

Many physics briefings were presented since last LHCC, for the LHCP, EPS, and SUSY conferences: [link here](#)

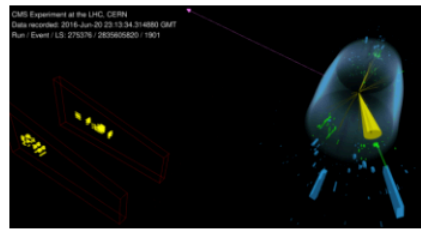

## A NEW WINDOW INTO THE SHADOW WORLD: EXOTIC PARTICLE DECAYS IN THE MUON DETECTORS

27 AUG 2021

A new window into the shadow world: exotic particle decays in the muon detectors As physicists seek the elusive particles that may reveal a new understanding of the universe's inner workings, one intriguing possibility is the conceivable existence...

[READ MORE](#)

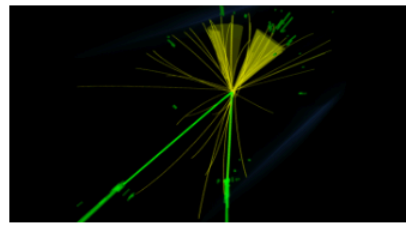

## LIVE LONG AND PROSPER: SEARCHING FOR THE LONG-LIVED RELATIVES OF THE HIGGS BOSON

16 AUG 2021

Live long and prosper: Searching for the long-lived relatives of the Higgs boson A recent result from CMS searches for long-lived particles through the so-called "Higgs portal" in ways never done before. For about a decade now the CMS experiment at...

[READ MORE](#)

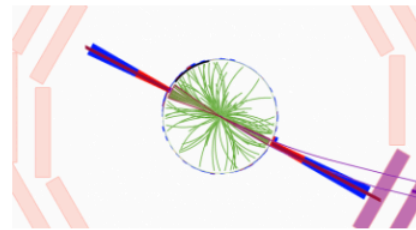

## ANY MORE HIGGSSES WE SHOULD KNOW ABOUT?

04 AUG 2021

This year marked the ninth anniversary of the discovery of the Higgs boson; the Standard Model particle linked to the mystery of creating the mass of all the other fundamental particles through the so-called Higgs mechanism. While a single Higgs...

[READ MORE](#)

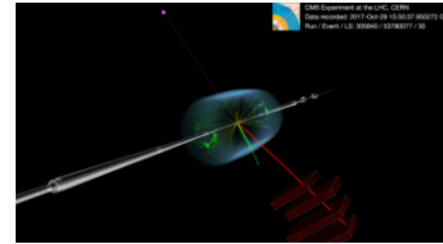

## SEARCHING FOR THE DARK SIDE OF THE UNIVERSE

02 AUG 2021

Could you imagine what the dark part of the universe is like? The Standard Model of Particle Physics explains matter at the subatomic level and the related phenomena such as interactions and forces between the subatomic particles. Still, we already...

[READ MORE](#)

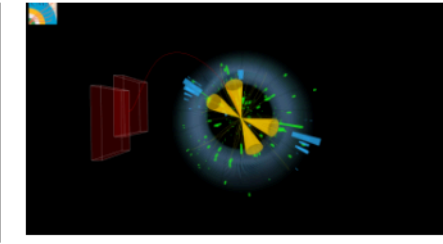

## THE FOUR BEAUTIES IN THE TALE OF TWO HIGGSSES

30 JUL 2021

The interaction of the Higgs boson with its own field leads to its mass generation. Since the Higgs boson mass has already been measured, the study of the Higgs pair production at the LHC reveals directly the strength of the Higgs self coupling  $\lambda_{HHH}$ ...

[READ MORE](#)

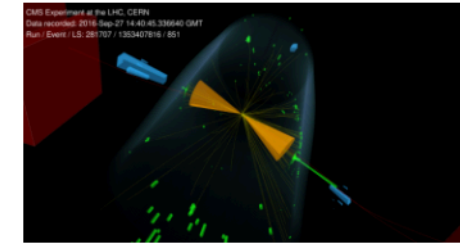

## JETS-OF-ALL-TRADES: CONSTRAINING STANDARD MODEL AND BEYOND

25 JUL 2021

For the first time, CMS physicists extract the fundamental parameters of QCD together with constraints on the New Physics. Any tiny failure of the Standard Model to explain data behaviour is a possible window for the New Physics. An example is...

[READ MORE](#)

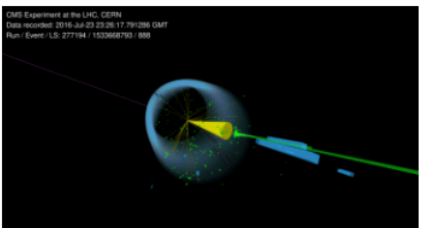

## A TALE OF TWO COLLIDERS AND THE UNRIVALLED PRECISION ON THE Z INVISIBLE WIDTH

19 JUL 2021

The most powerful particle collider in the world, the Large Hadron Collider (LHC), was built in the 27 km tunnel originally excavated for the highest energy electron-positron collider ever built, LEP. As an extraordinarily sensitive machine, LEP was...

[READ MORE](#)

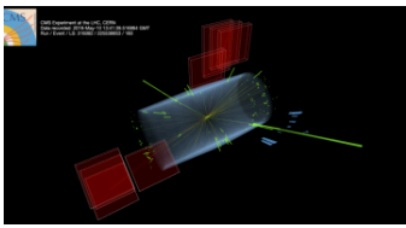

## USING THE GOLDEN DECAY CHANNEL TO UNDERSTAND THE PRODUCTION OF THE HIGGS BOSON

10 JUN 2021

Using the golden decay channel to understand the production of the Higgs boson The standard model of particle physics is currently the best way to describe interactions of fundamental particles that make up our Universe. It has been tested over many...

[READ MORE](#)

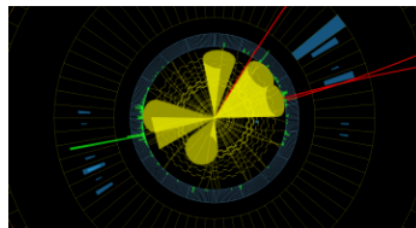

## WHAT DOES THE DECAY OF A BOTTOM QUARK LOOK LIKE?

09 JUN 2021

What does the decay of a bottom quark look like? Fragmentation, also known as hadronization, is when particles that contain quarks or gluons create other particles via the strong interaction. The fragmentation process cannot be exactly calculated...

[READ MORE](#)

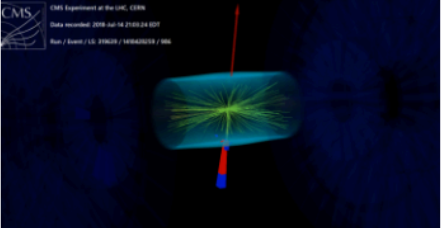

## A SHOT IN THE DARK: CAN JETS RECOIL AGAINST DARK MATTER?

07 JUN 2021

A shot in the dark: Can jets recoil against Dark Matter? In their 2020 hit single 'A Shot in the Dark' the rock band AC/DC got it right in many ways: "A shot in the dark Make you feel alright A shot in the dark All through the whole night" The...

[READ MORE](#)

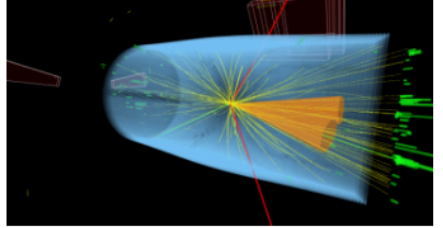

## USING MACHINE LEARNING TO IMPROVE THE DETECTION OF NEW PHYSICS IN THE INTERACTIONS OF THE TOP QUARK

04 JUN 2021

Using machine learning to improve the detection of new physics in the interactions of the top quark Although our theory describing the interactions between fundamental particles is exceptionally successful, it has weaknesses. You may have heard...

[READ MORE](#)

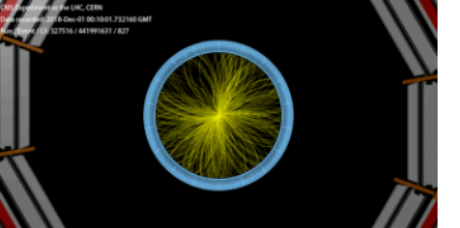

## EXPLORING THE PHYSICS PROCESSES INSIDE THE HOTTEST MATTER IN THE UNIVERSE

04 JUN 2021

Quarks are elementary particles in the Standard Model and the building blocks of the protons and neutrons in atoms. The dominant force between quarks is the strong interaction. Gluons are the force carriers of the strong interaction, and one thing...

[READ MORE](#)



# Summer 2021 publication activity

## TOP

1020	<a href="#">TOP-19-009</a>	Measurement of the top quark mass using events with a single reconstructed top quark in pp collisions at $\sqrt{s} = 13$ TeV	Submitted to JHEP	24 August 2021
1019	<a href="#">TOP-20-001</a>	Measurement of differential $t\bar{t}$ production cross sections in the full kinematic range using lepton+jets events from proton-proton collisions at $\sqrt{s} = 13$ TeV	Submitted to PRD	5 August 2021
1018	<a href="#">TOP-21-001</a>	Probing effective field theory operators in the associated production of top quarks with a Z boson in multilepton final states at $\sqrt{s} = 13$ TeV	Submitted to JHEP	29 July 2021
1012	<a href="#">TOP-18-010</a>	Measurement of the inclusive and differential $t\bar{t}\gamma$ cross sections in the single-lepton channel and EFT interpretation at $\sqrt{s} = 13$ TeV	Submitted to JHEP	3 July 2021

## HIG

1015	<a href="#">HIG-20-015</a>	Measurement of the inclusive and differential Higgs boson production cross sections in the decay mode to a pair of $\tau$ leptons in pp collisions at $\sqrt{s} = 13$ TeV	Submitted to PRL	23 July 2021
1005	<a href="#">HIG-20-014</a>	Search for a heavy Higgs boson decaying into two lighter Higgs bosons in the $\tau\tau bb$ final state at 13 TeV	Submitted to JHEP	18 June 2021

## SMP

1007	<a href="#">SMP-20-016</a>	Measurement of the electroweak production of $Z\gamma$ and two jets in proton-proton collisions at $\sqrt{s} = 13$ TeV and constraints on anomalous quartic gauge couplings	Submitted to PRD	21 June 2021
1010	<a href="#">SMP-20-012</a>	Measurements of the electroweak diboson production cross sections in proton-proton collisions at $\sqrt{s} = 5.02$ TeV using leptonic decays	Submitted to PRL	2 July 2021

## BPH

1011	<a href="#">BPH-18-003</a>	Measurement of prompt open-charm production cross sections in proton-proton collisions at $\sqrt{s} = 13$ TeV	Submitted to JHEP	3 July 2021
------	----------------------------	---	-------------------	-------------



# Summer 2021 publication activity

## EXO

1017	<a href="#">EXO-20-004</a>	Search for new particles in events with energetic jets and large missing transverse momentum in proton-proton collisions at $\sqrt{s} = 13$ TeV	Submitted to JHEP	27 July 2021
1013	<a href="#">EXO-20-015</a>	Search for long-lived particles decaying in the CMS endcap muon detectors in proton-proton collisions at $\sqrt{s} = 13$ TeV	Submitted to PRL	10 July 2021
1006	<a href="#">EXO-20-001</a>	Search for $W\gamma$ resonances in proton-proton collisions at $\sqrt{s} = 13$ TeV using hadronic decays of Lorentz-boosted W bosons	Submitted to PLB	19 June 2021

## SUS

1016	<a href="#">SUS-20-003</a>	Search for chargino-neutralino production in events with Higgs and W bosons using $137 \text{ fb}^{-1}$ of proton-proton collisions at $\sqrt{s} = 13$ TeV	Submitted to JHEP	26 July 2021
1014	<a href="#">SUS-20-002</a>	Combined searches for the production of supersymmetric top quark partners in proton-proton collisions at $\sqrt{s} = 13$ TeV	Submitted to EPJC	22 July 2021
1009	<a href="#">SUS-19-012</a>	Search for electroweak production of charginos and neutralinos in proton-proton collisions at $\sqrt{s} = 13$ TeV	Submitted to JHEP	27 June 2021

## HIN

1008	<a href="#">HIN-19-007</a>	Fragmentation of jets containing a prompt $J/\psi$ meson in PbPb and pp collisions at $\sqrt{s_{NN}} = 5.02$ TeV	Submitted to PLB	23 June 2021
------	----------------------------	--	------------------	--------------



# Measurement of the Z invisible width

- Z invisible width extracted from ratio of **measured cross sections of Z( $\nu\nu$ ) + jets to Z( $ll$ ) + jets:**

$$\Gamma(Z \rightarrow \nu\bar{\nu}) = \frac{\sigma(Z + \text{jets})\mathcal{B}(Z \rightarrow \nu\bar{\nu})}{\sigma(Z + \text{jets})\mathcal{B}(Z \rightarrow ll)}\Gamma(Z \rightarrow ll)$$

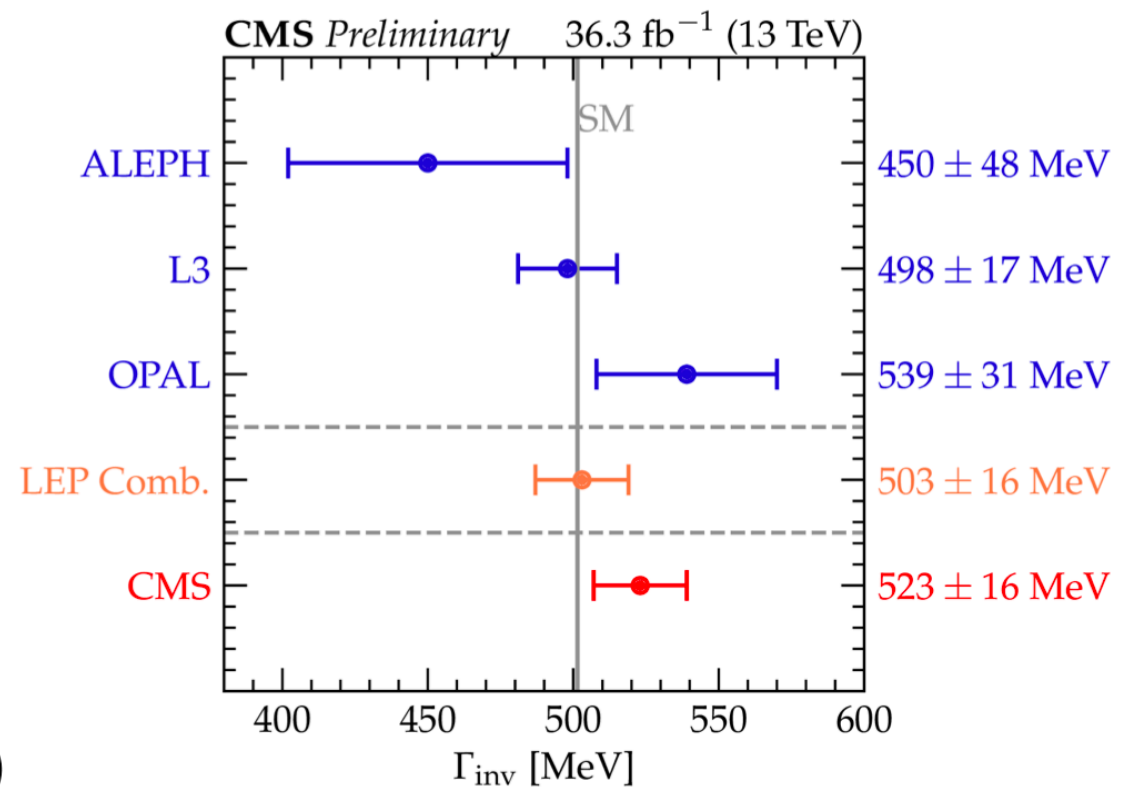
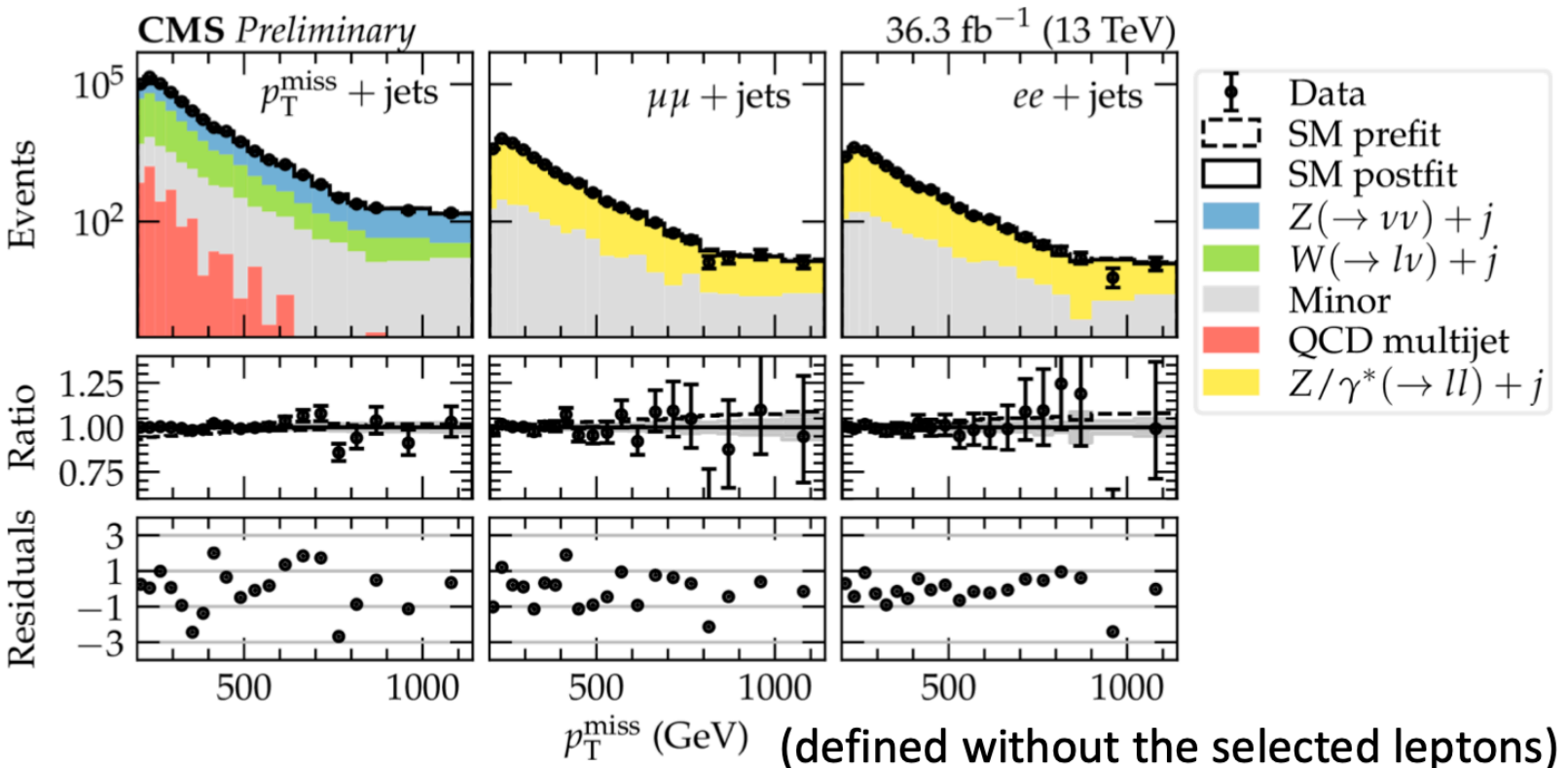

- $\Gamma_{\text{inv}} = 523 \pm 3 \text{ (stat)} \pm 16 \text{ (syst)} \text{ MeV}$

- Single **most precise direct measurement of the Z invisible width**
- Similar to combined LEP result



# CP violation in semileptonic top pair events

- Measure **asymmetry of 4 T-odd observables** which if CPT is conserved are also odd under CP transformation

$$A_{CP}(O_i) = \frac{N_{\text{events}}(O_i > 0) - N_{\text{events}}(O_i < 0)}{N_{\text{events}}(O_i > 0) + N_{\text{events}}(O_i < 0)}, i = 3, 6, 12, 14$$

- Lepton + jets final states
- Top candidates reconstructed w/ a  $\chi^2$  sorting algorithm

- **All measures asymmetries consistent with 0 indicating no CPV**

- Factor 3 **reduced uncertainties** w.r.t. 8 TeV result

[CMS-PAS-TOP-20-005](#)

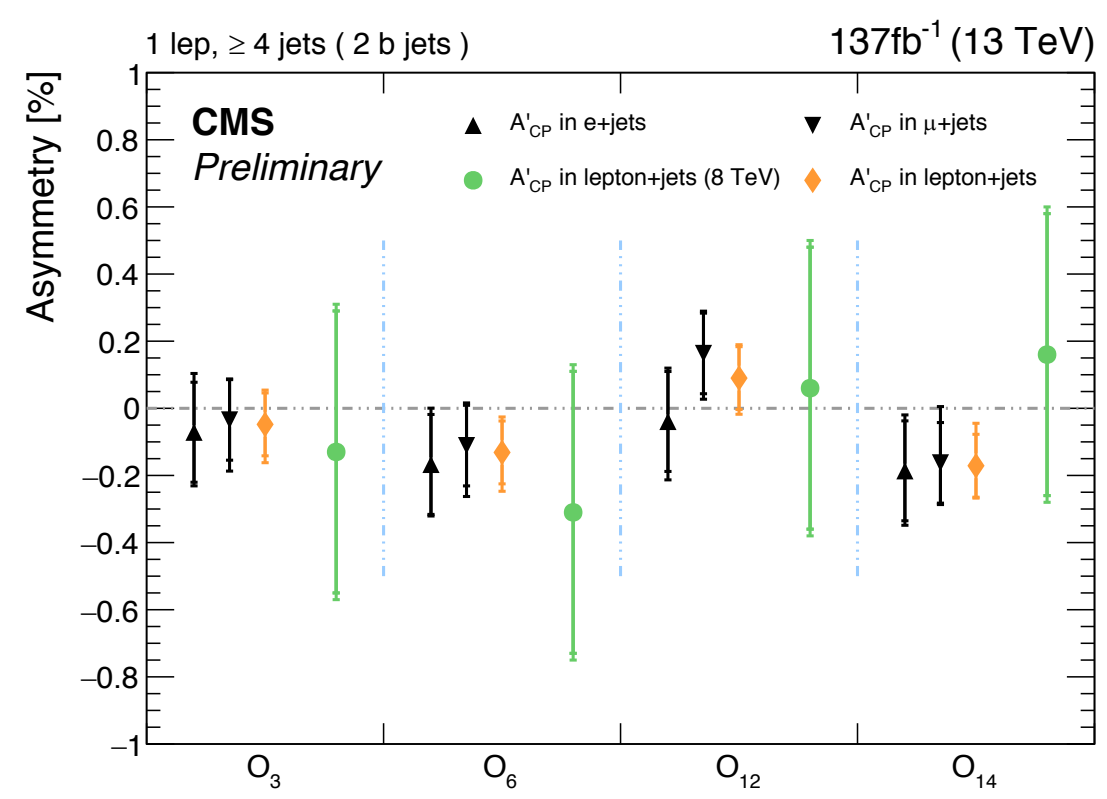
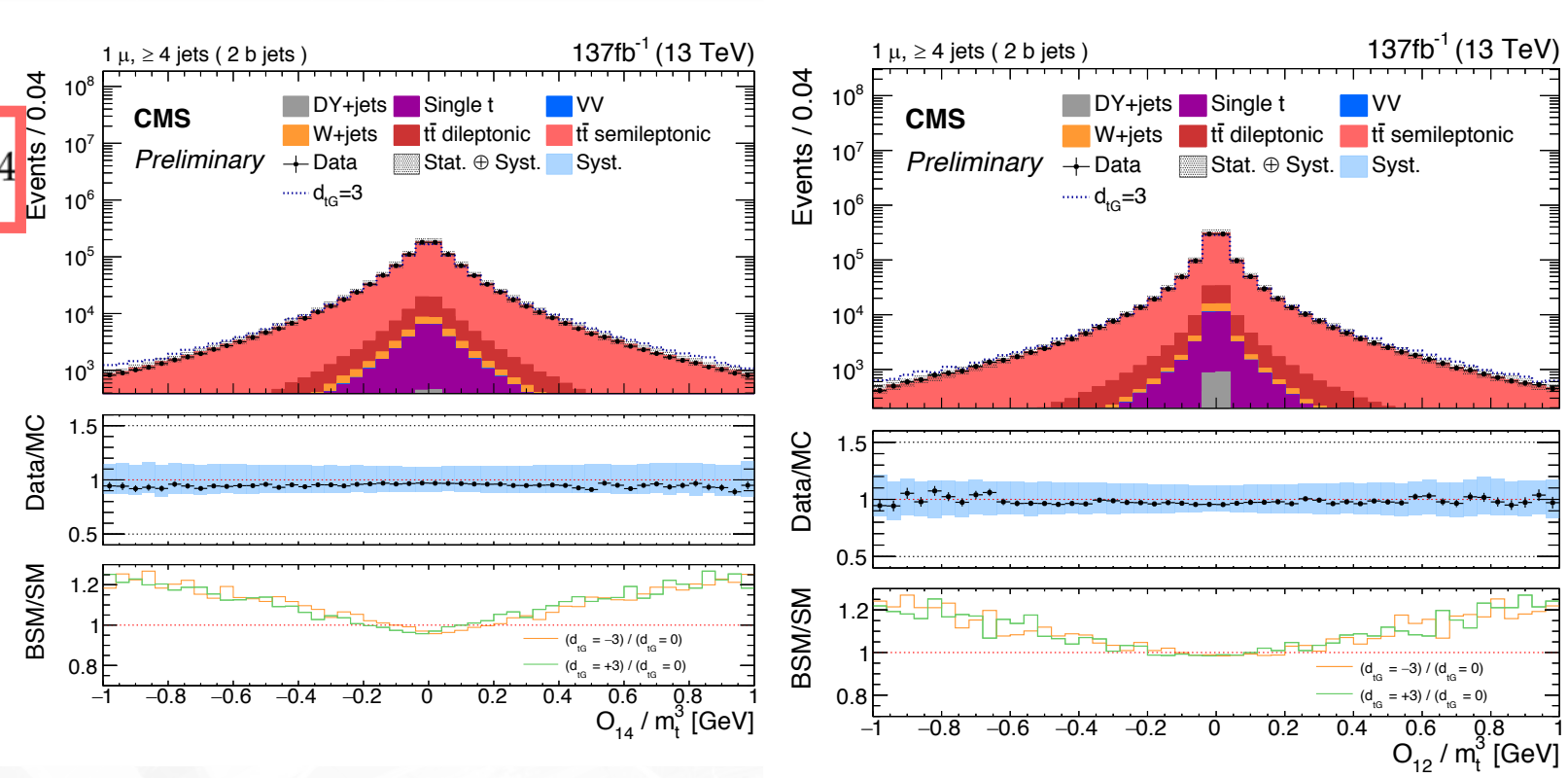



# Observation of triple J/ψ production

- Golden channel for **double (DPS) and triple parton scattering (TPS)**

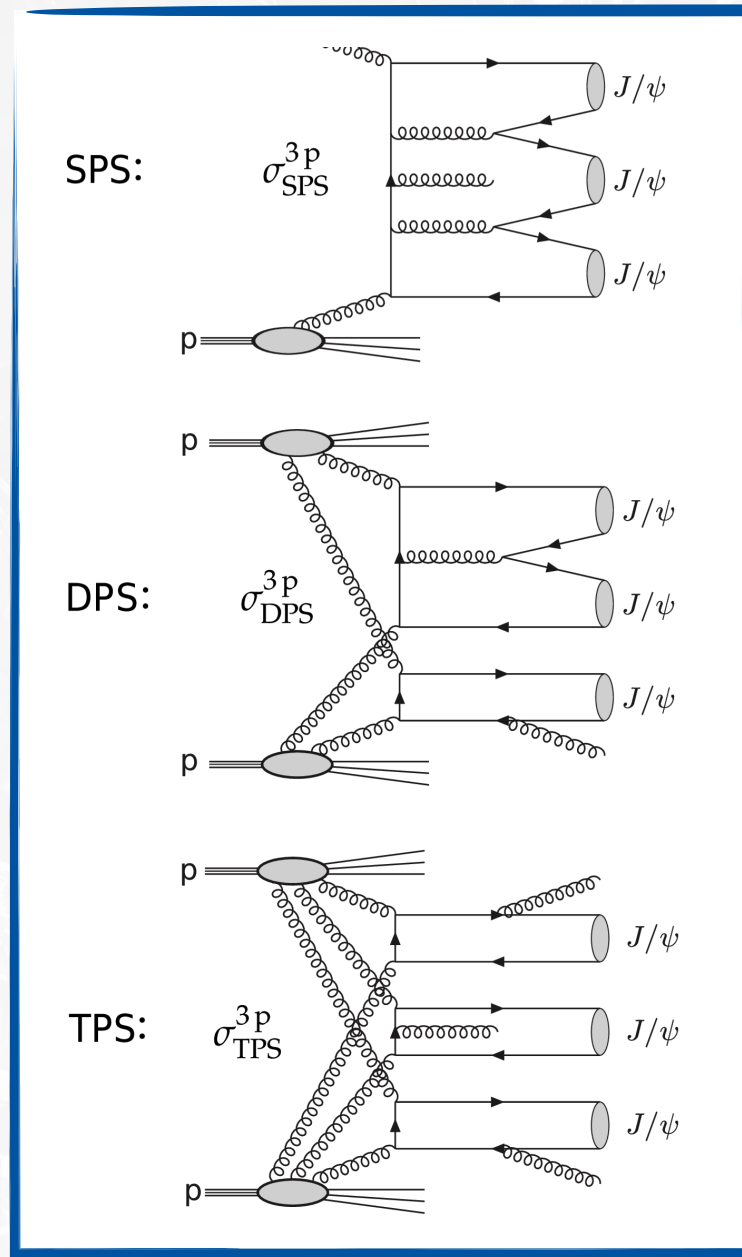

Select **6μ events** consistent with 3 J/ψ decays

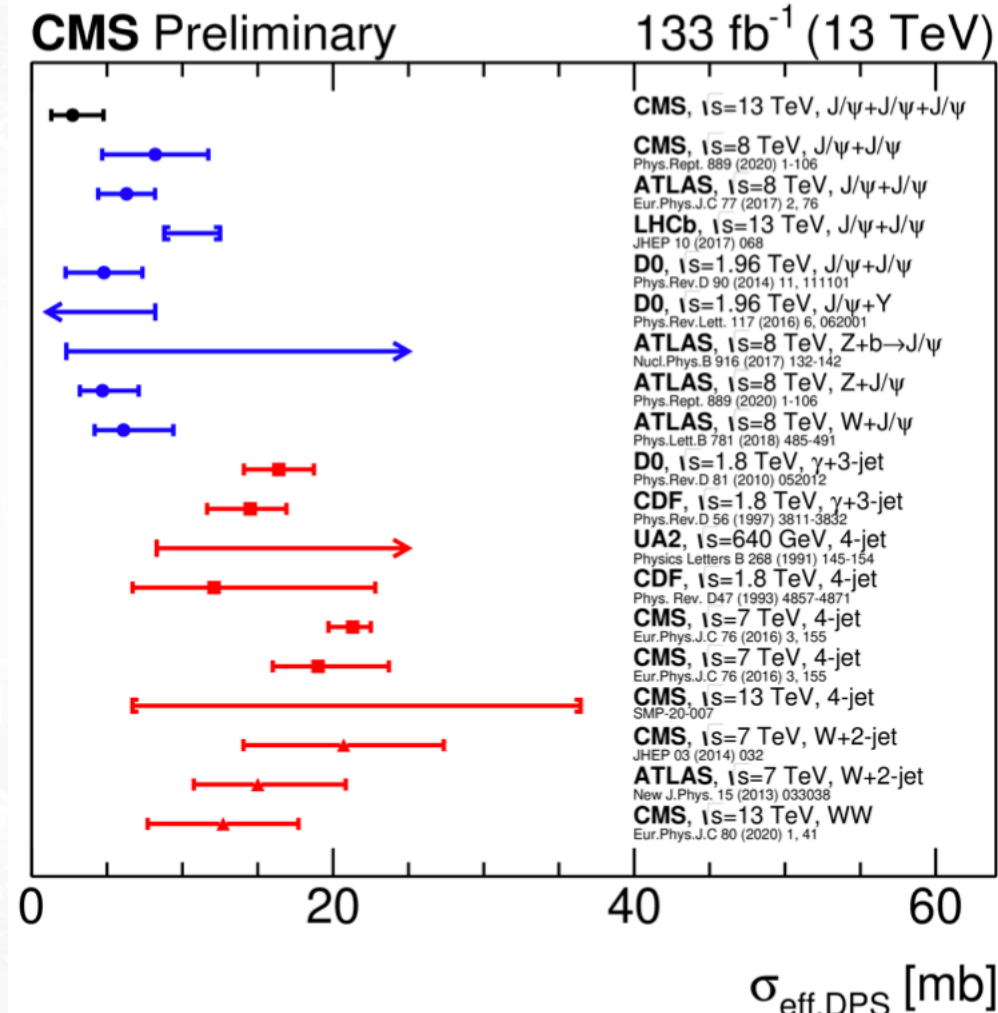
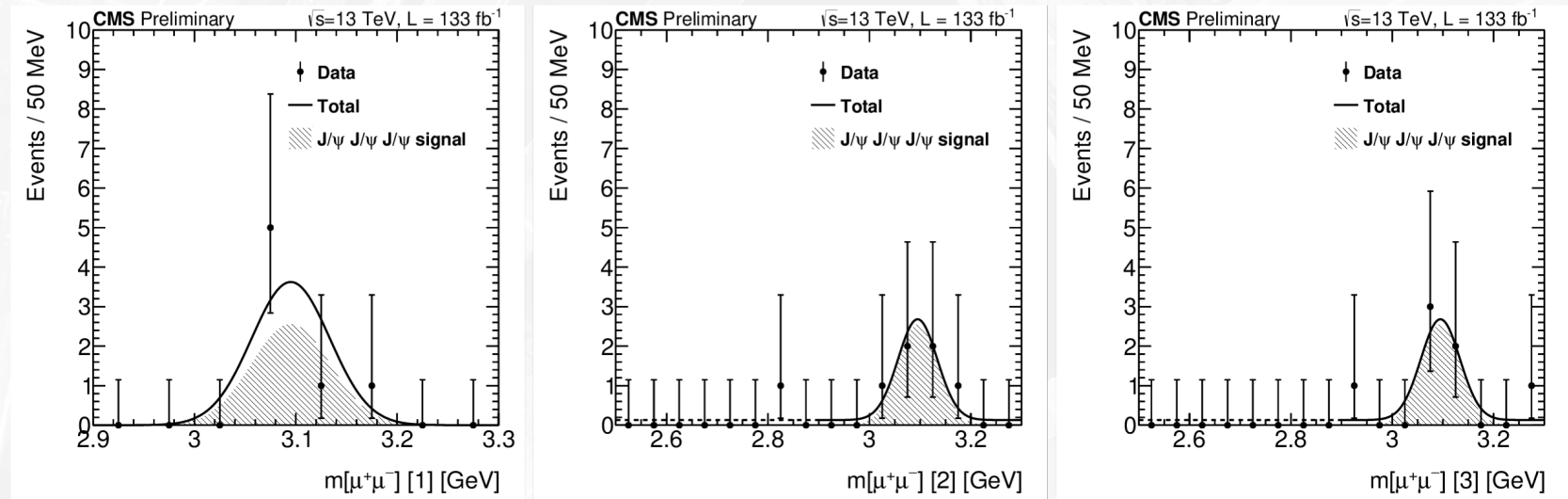

•  $\sigma(pp \rightarrow 3J/\psi X) = 272 \pm 118$  (stat)  $\pm 16$  (syst) fb

•  $\sigma_{eff,DPS} = 2.7 \pm 1.2$  (exp) + 1.5 (theo) mb



# Heavy resonance $X \rightarrow HH$

- $X \rightarrow HH \rightarrow 4b$  one pair boosted and other boosted or resolved
  - $X \rightarrow HH \rightarrow bbWW$  and  $X \rightarrow HH \rightarrow bb\tau\tau$  with one b-pair boosted
- Deep neural network used to **tag boosted Higgs decays** and categorize events
- Signal extracted from a **2D fit to Higgs and X** reconstructed masses

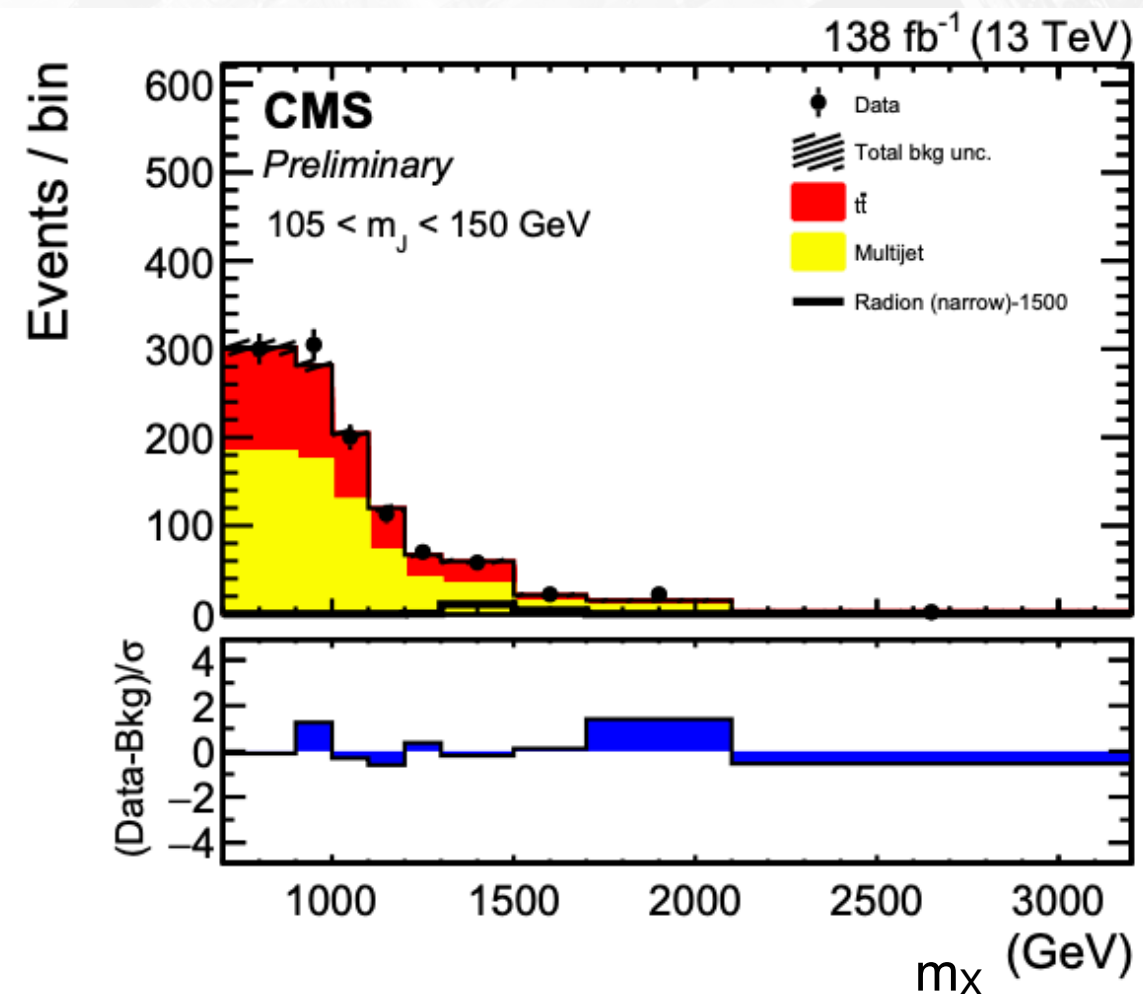
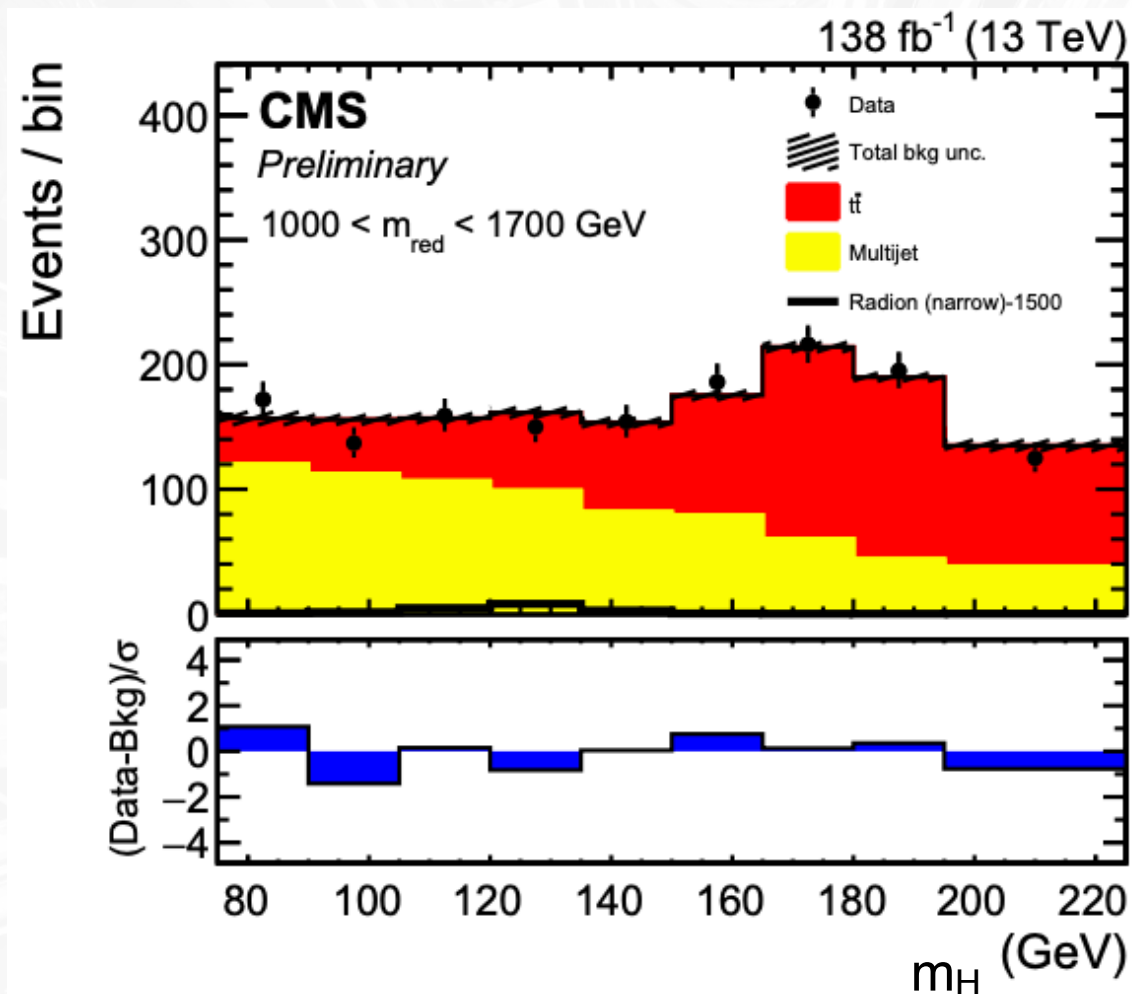



# Heavy resonance $X \rightarrow HH$

- $X \rightarrow HH \rightarrow 4b$  one pair boosted and other boosted or resolved
- $X \rightarrow HH \rightarrow bbWW$  and  $X \rightarrow HH \rightarrow bb\tau\tau$  with one b-pair boosted

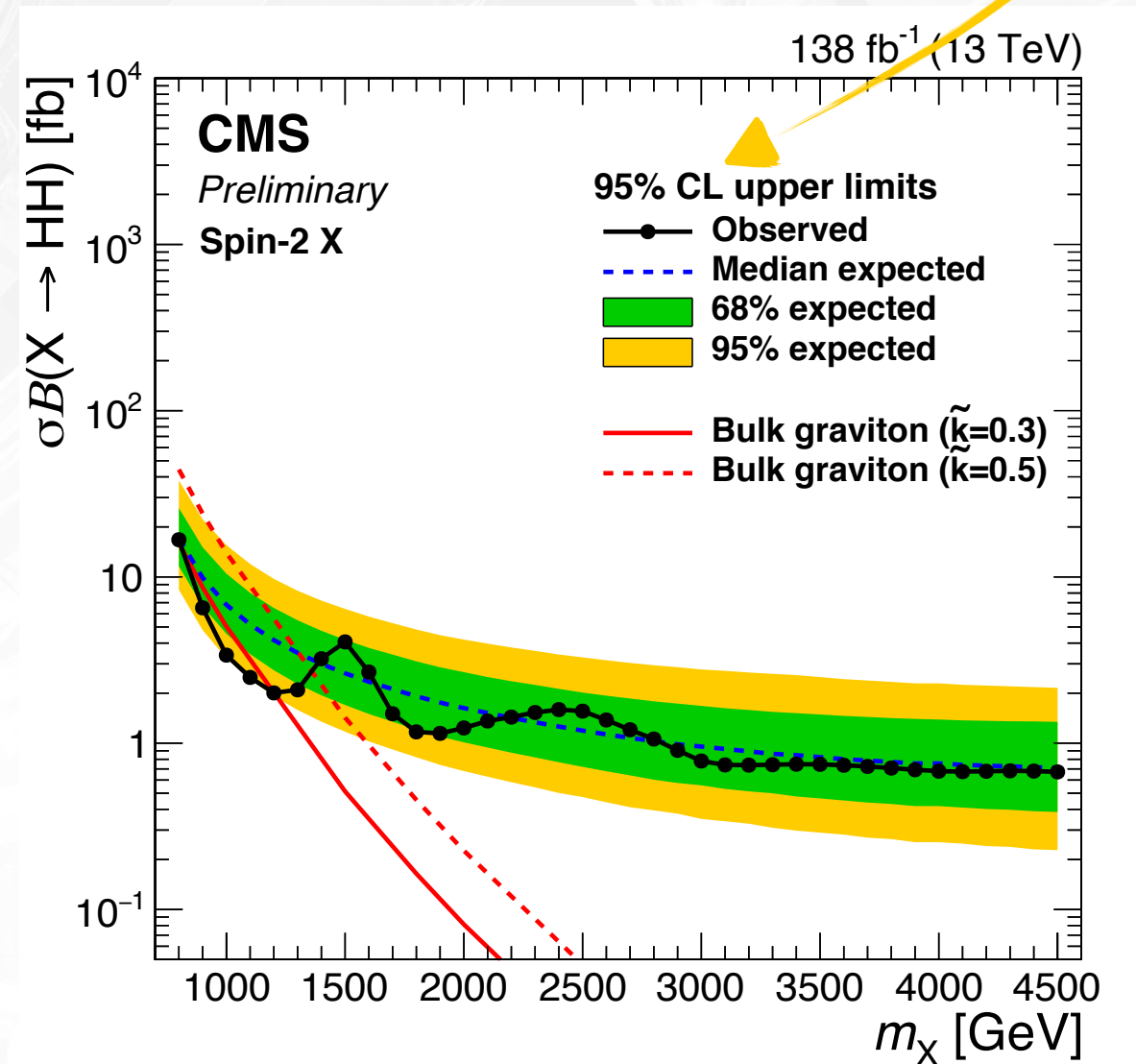
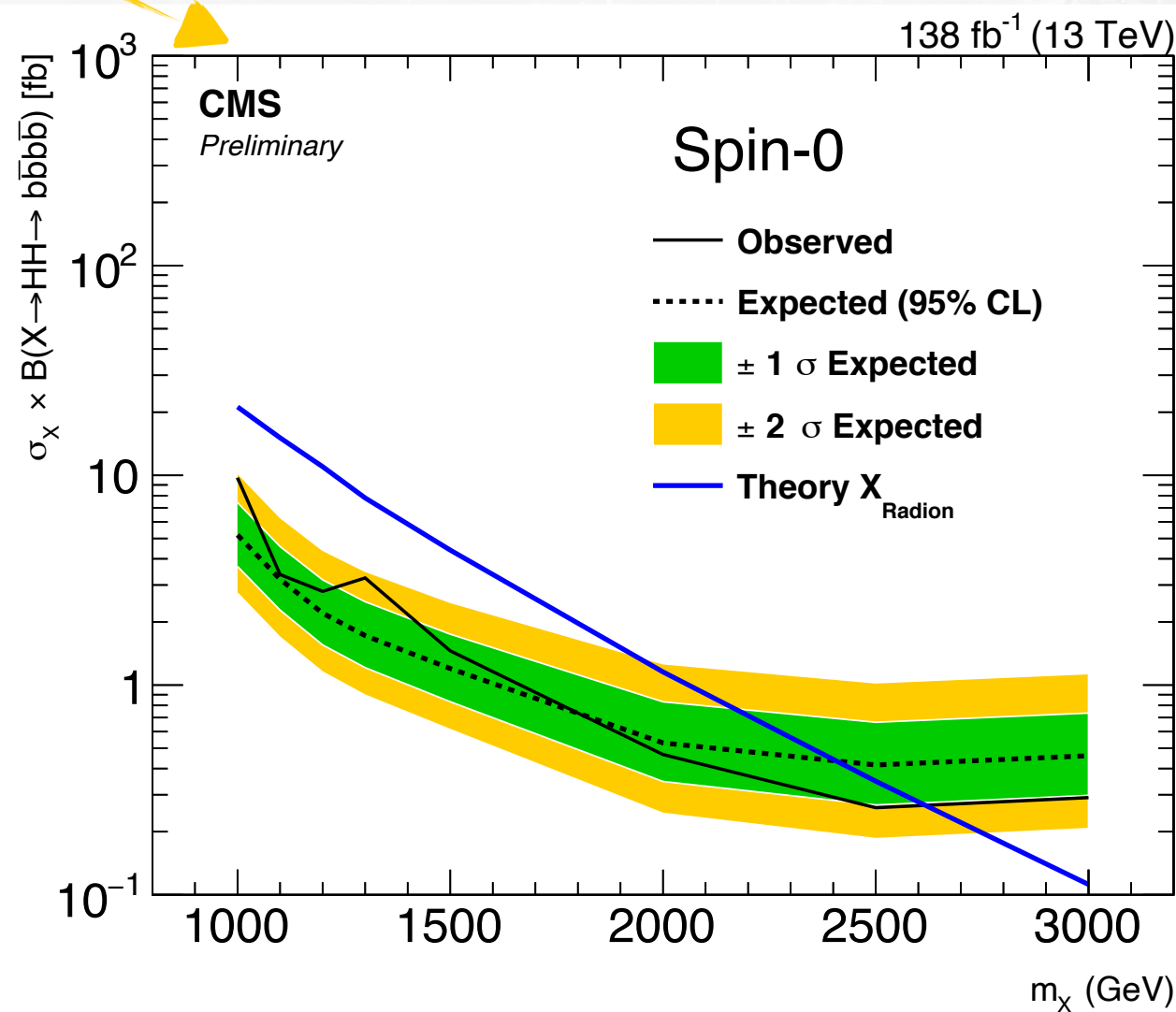

- Sensitivity improved about 6-14 times w.r.t. 2016 only analysis



# Three W bosons resonances

- New resonances decay via a scalar radion R:  $W_{KK} \rightarrow WR \rightarrow WWW$
- **Resolved** & **Merged** fully hadronic decays

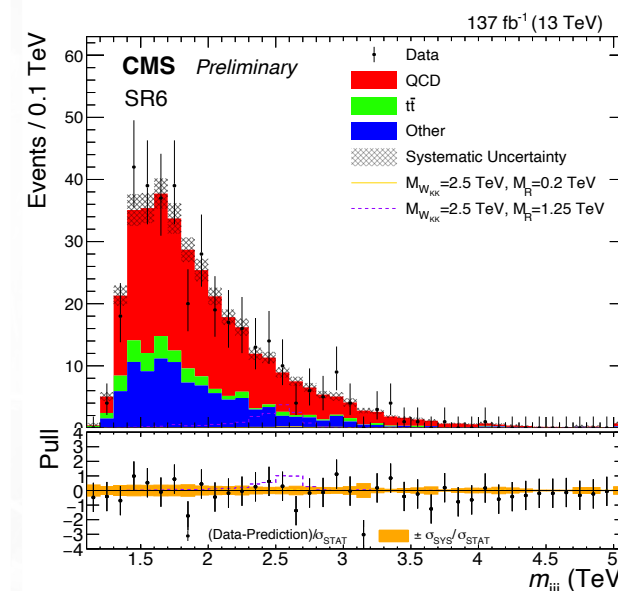
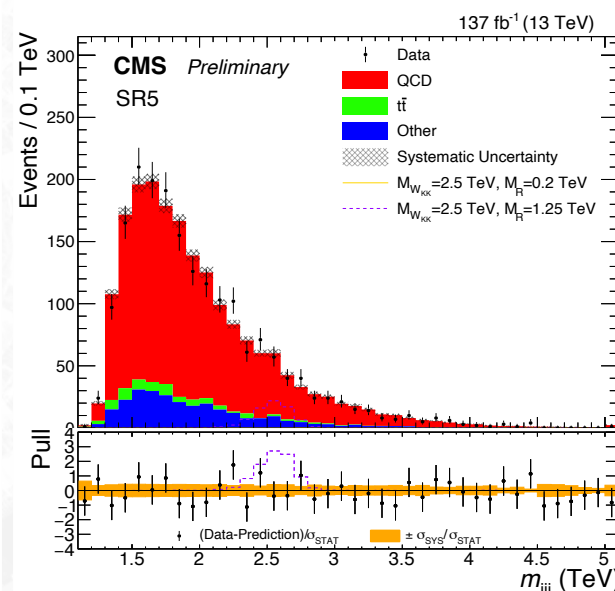
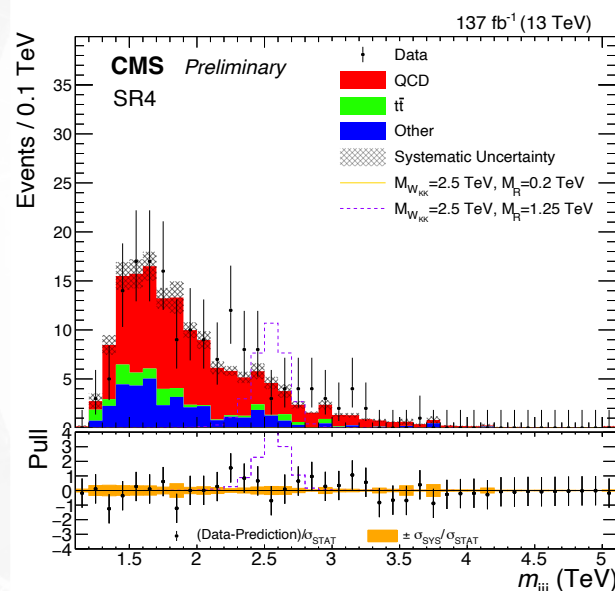
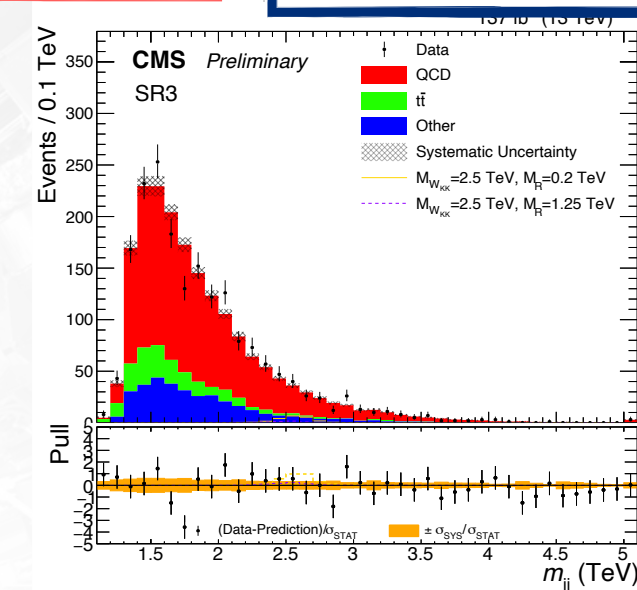
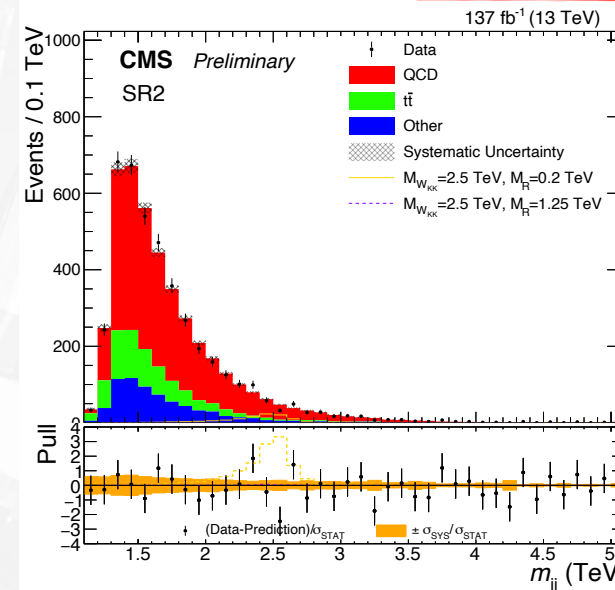
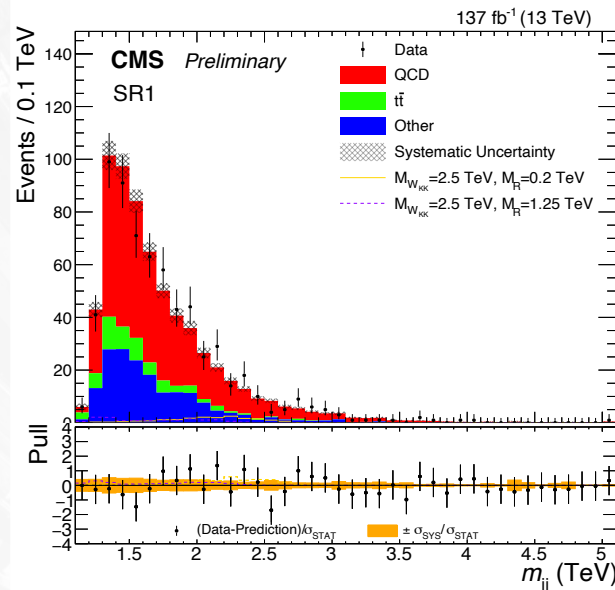
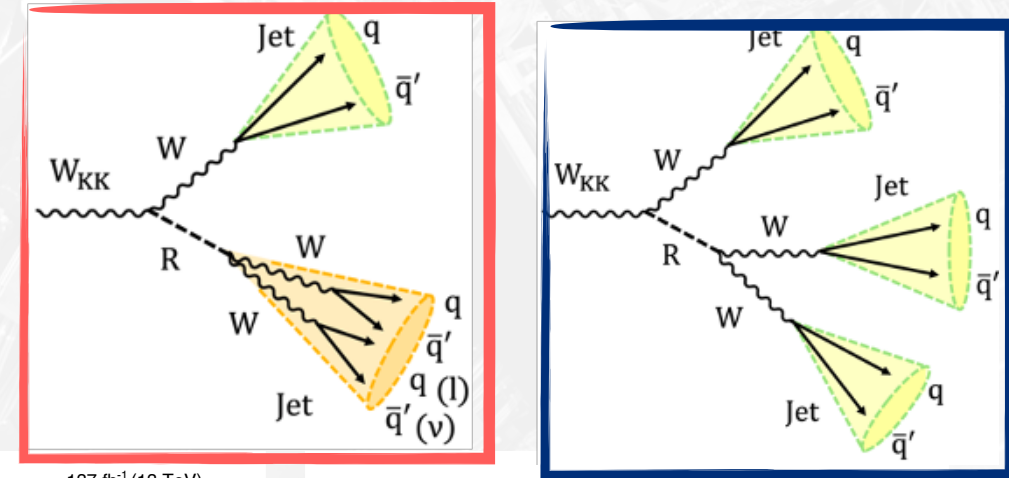



# Three W bosons resonances

- New resonances decay via a scalar radion R:  $W_{KK} \rightarrow WR \rightarrow WWW$
- **Resolved** & **Merged** fully hadronic decays

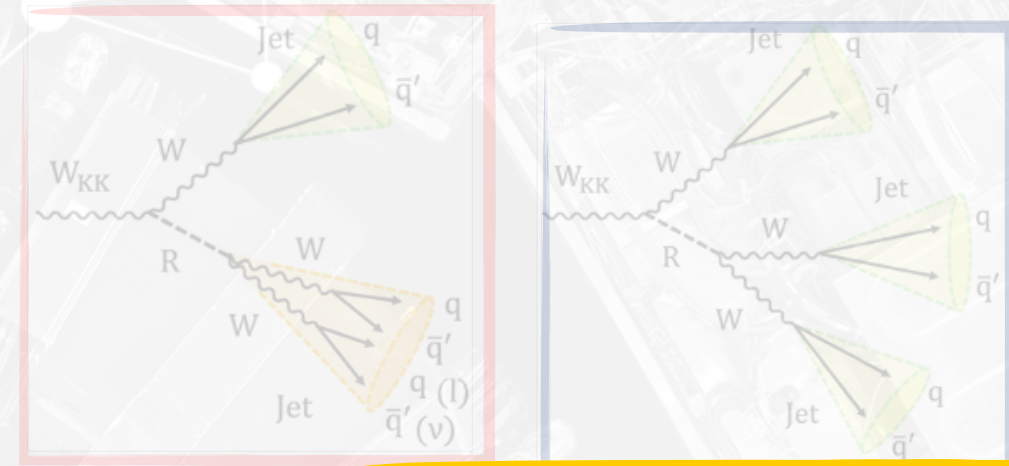

Fully hadronic

Hadronic+Leptonic

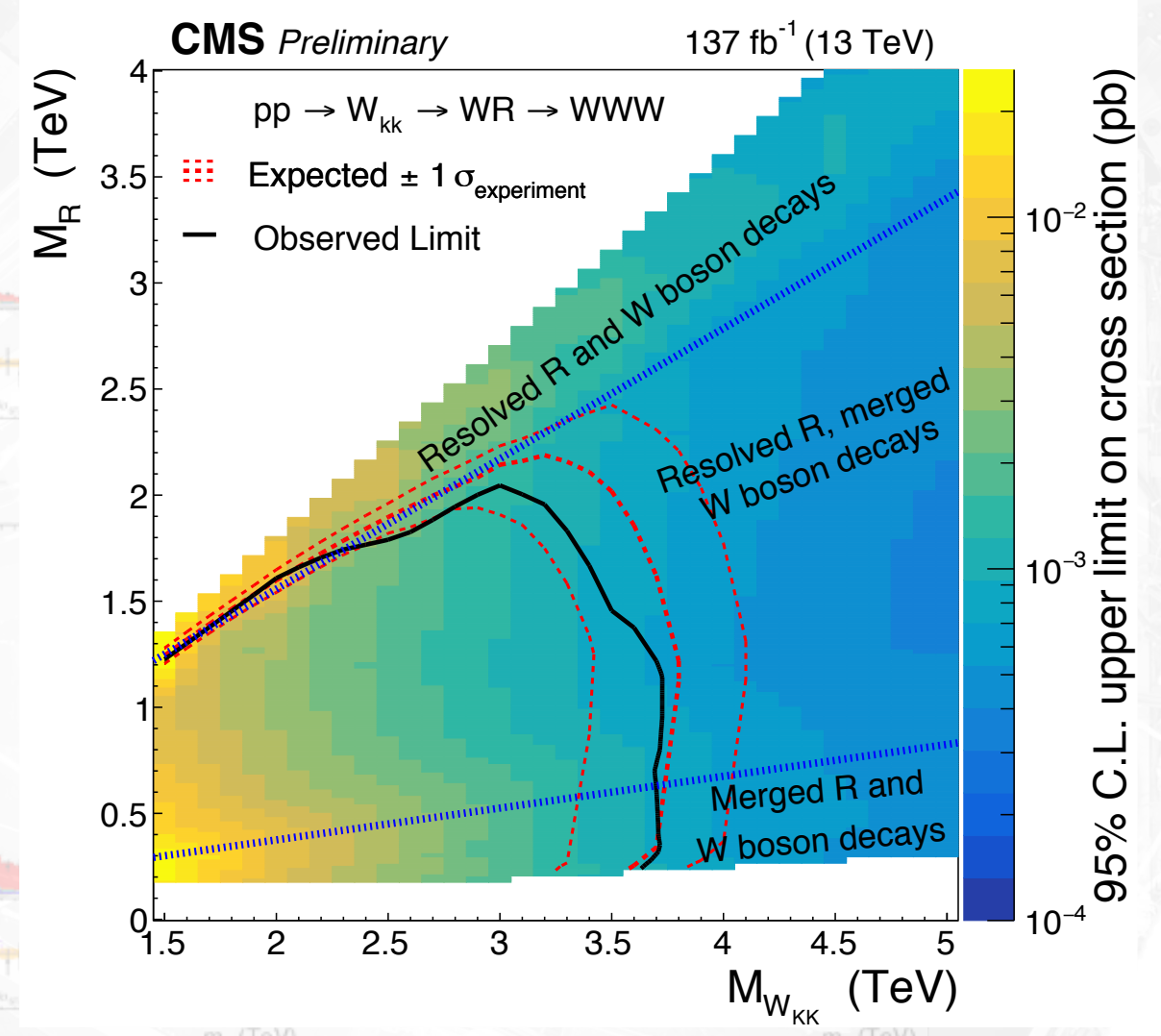
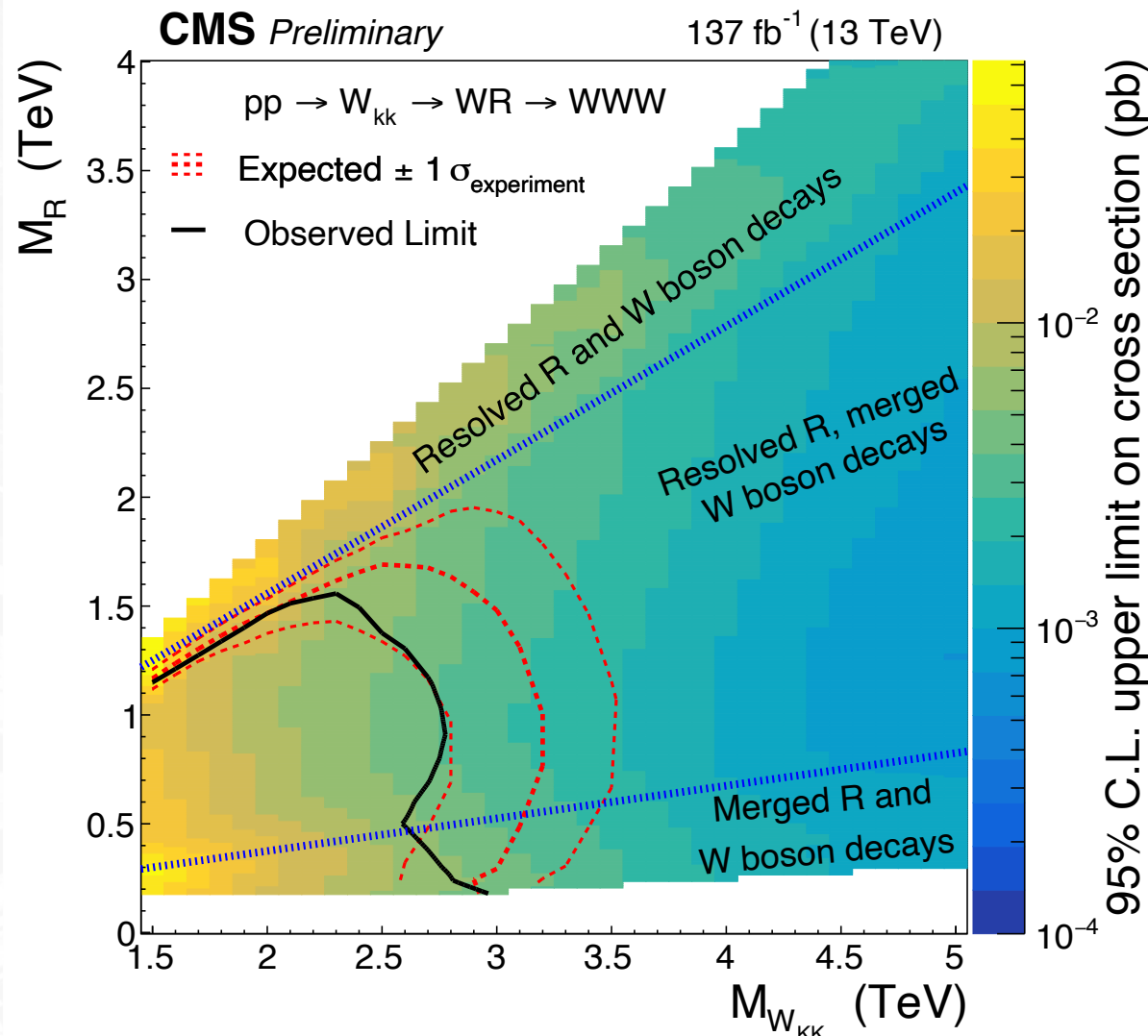



# Non conventional physics

## Overview of CMS EXO results

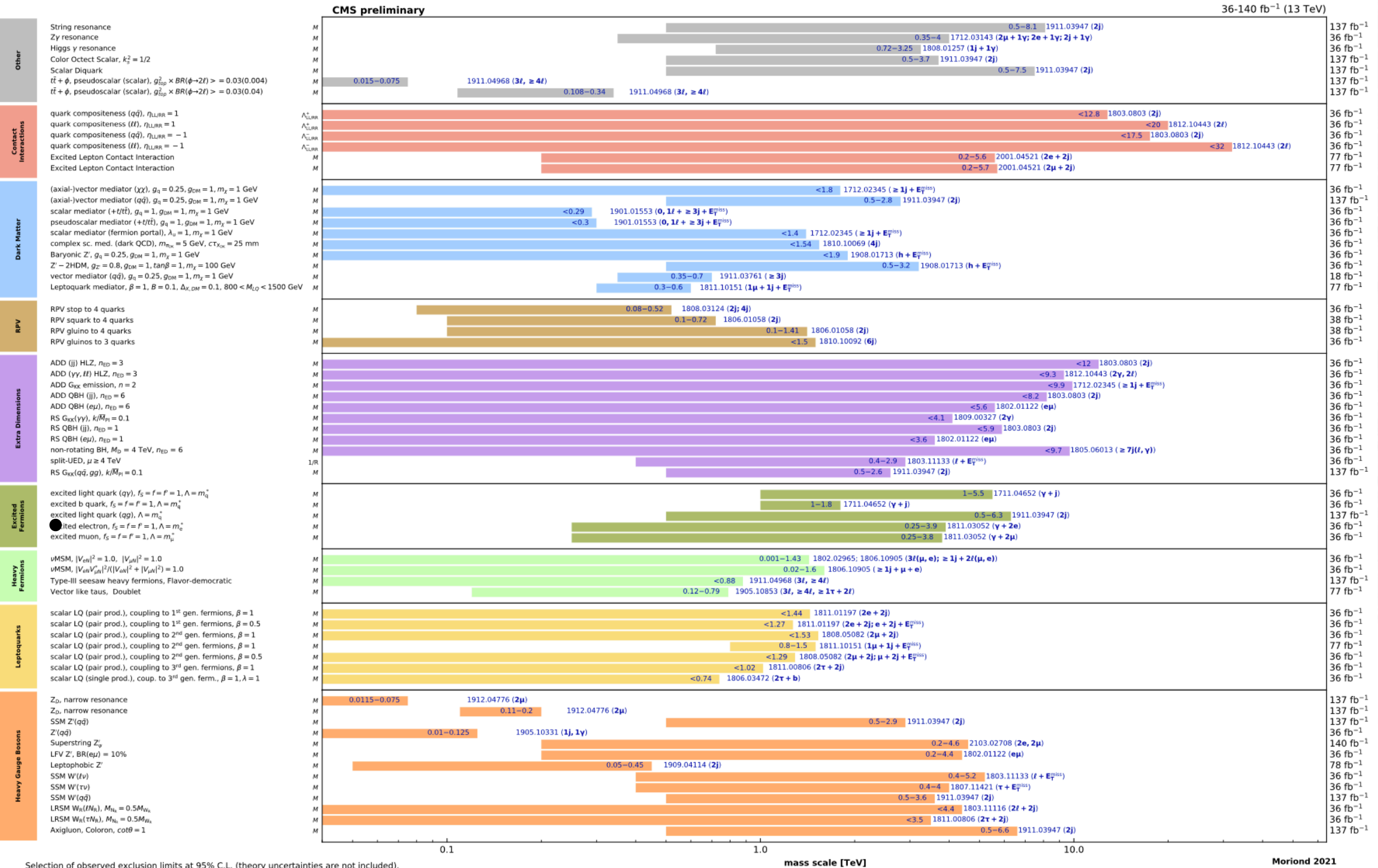



# Long lived Heavy Neutral Leptons

- HNL mix with SM neutrinos
- Small masses + small mixing → **long-lived HNL**
- Trigger on **prompt** | to enable sensitivity to low-momentum **displaced** |

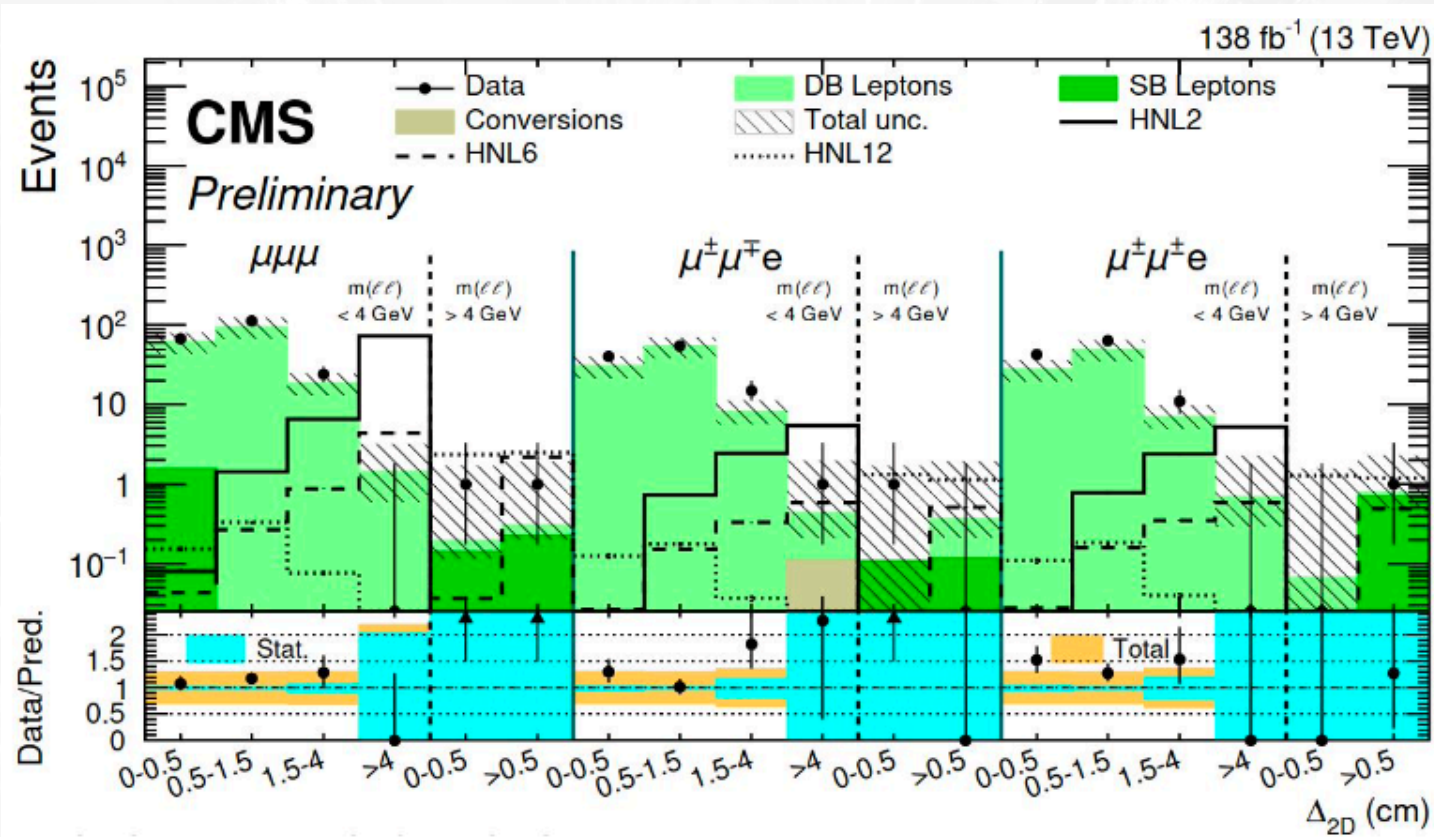
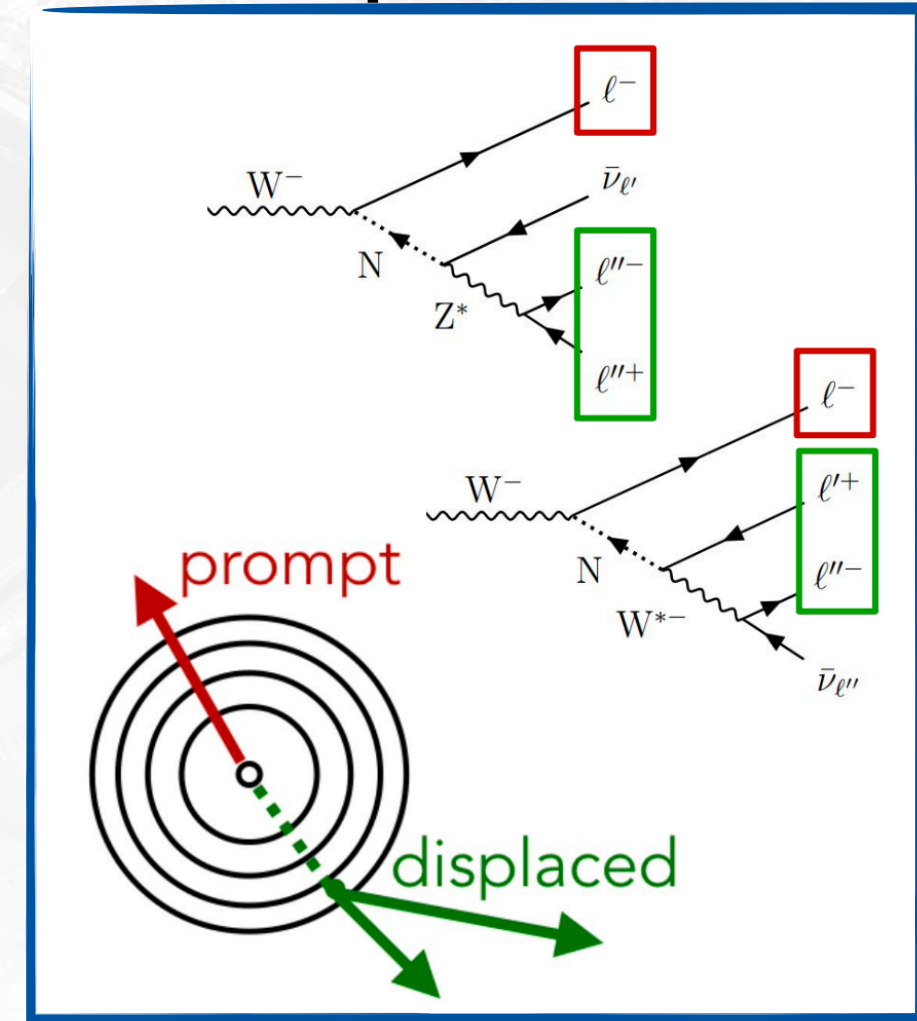

Constrain HNL neutrino mixing parameter values as a function of HNL mass

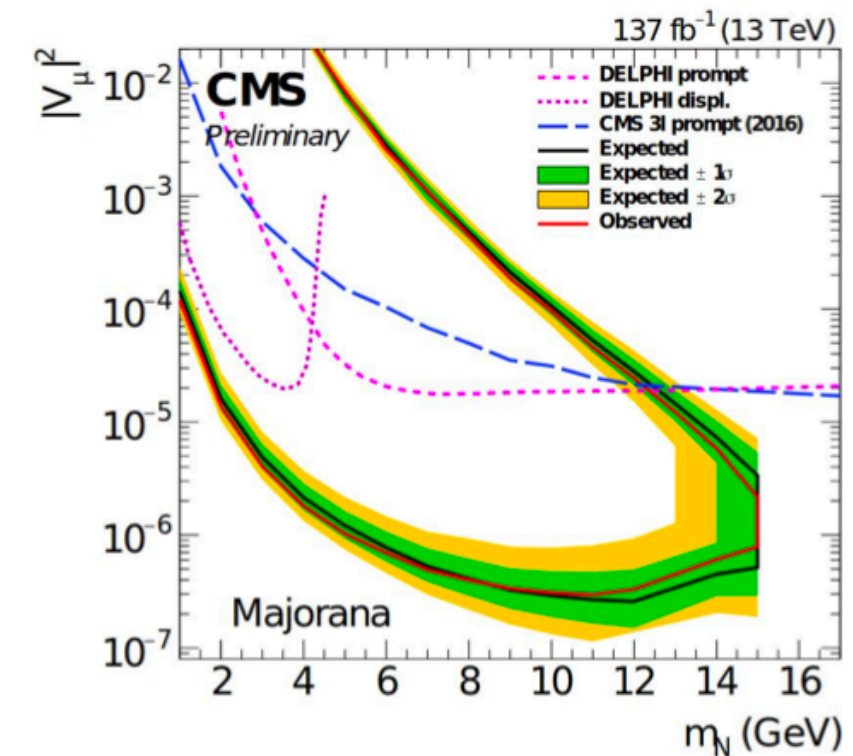





# *Phase 2 Activities*



# CMS Upgrade overview

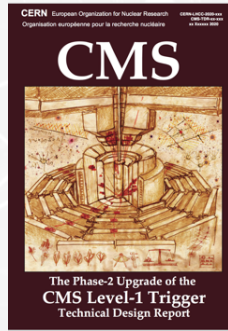

## L1-Trigger

- Tracks in L1-Trigger at 40 MHz
- PFlow selection 750 kHz L1

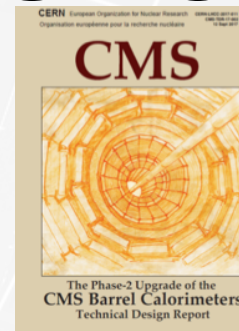

## Barrel Calorimeters

- ECAL readout at 40 MHz w/ precise timing at 30 GeV
- ECAL/HCAL new back-end boards

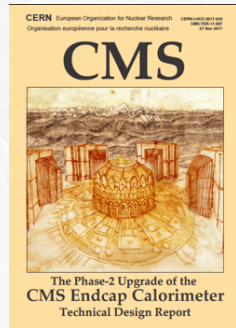

## Endcap Calorimeter

- 3D showers + precise timing
- Si, Scint+SiPM in Pb/W-SS



## Muon systems

- DT/CSC new FE/BE readout
- RPC back-end electronics
- New GEM/RPC  $1.6 < \eta < 2.4$
- Extended to  $\eta \approx 3$



## Tracker

- Si-Strip/Pixels increased granularity
- Tracking in L1-Trigger
- Extended coverage to  $\eta \approx 3.8$

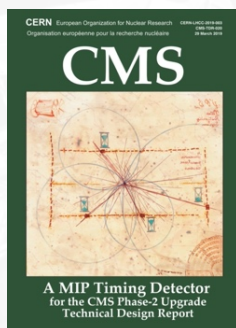

## MIP Timing Detector

- Precision timing with:
  - Barrel layer: Crystals + SiPMs
  - Endcap layer: Low Gain Avalanche Diodes

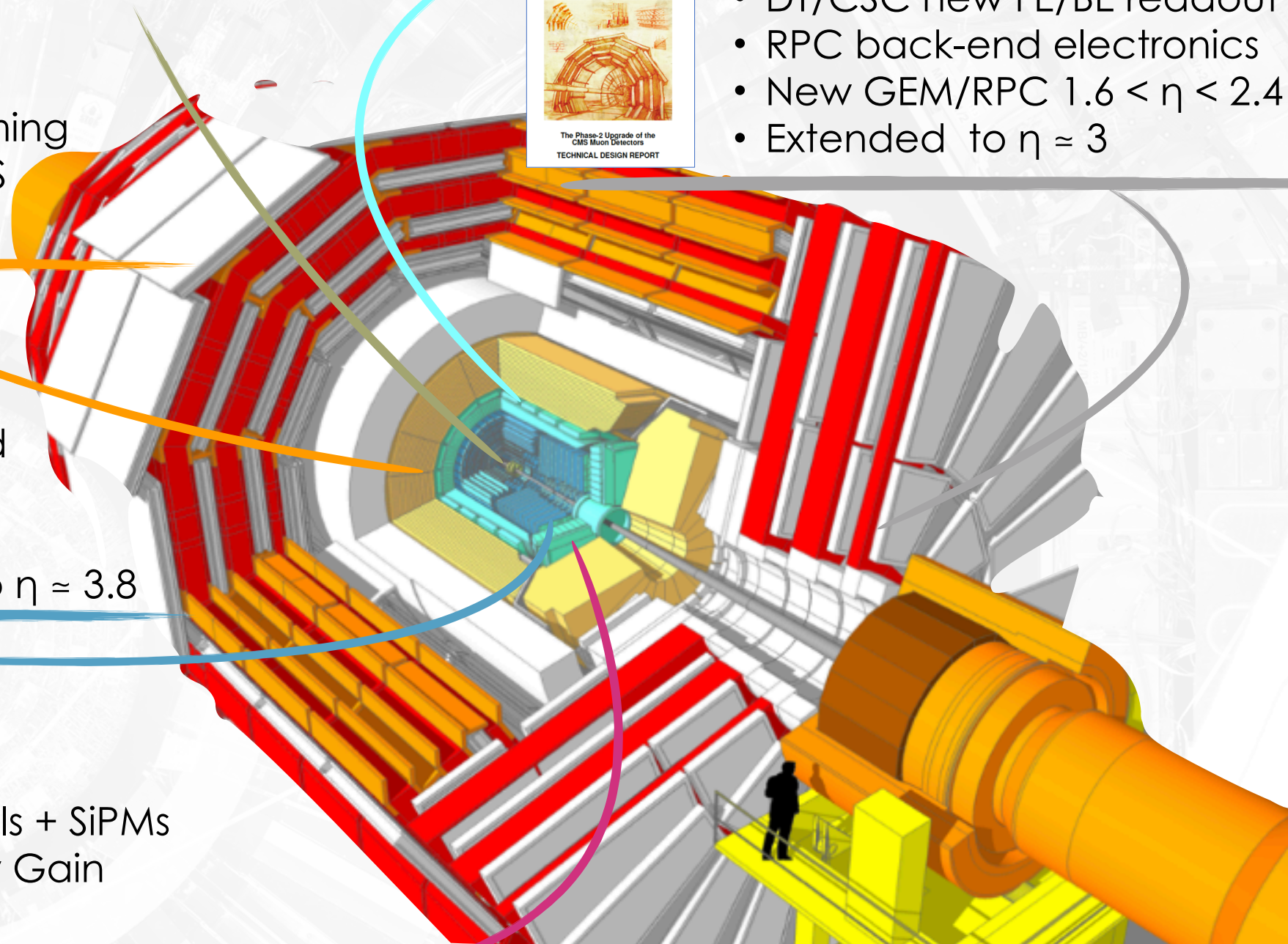



# Latest Upgrade TDRs

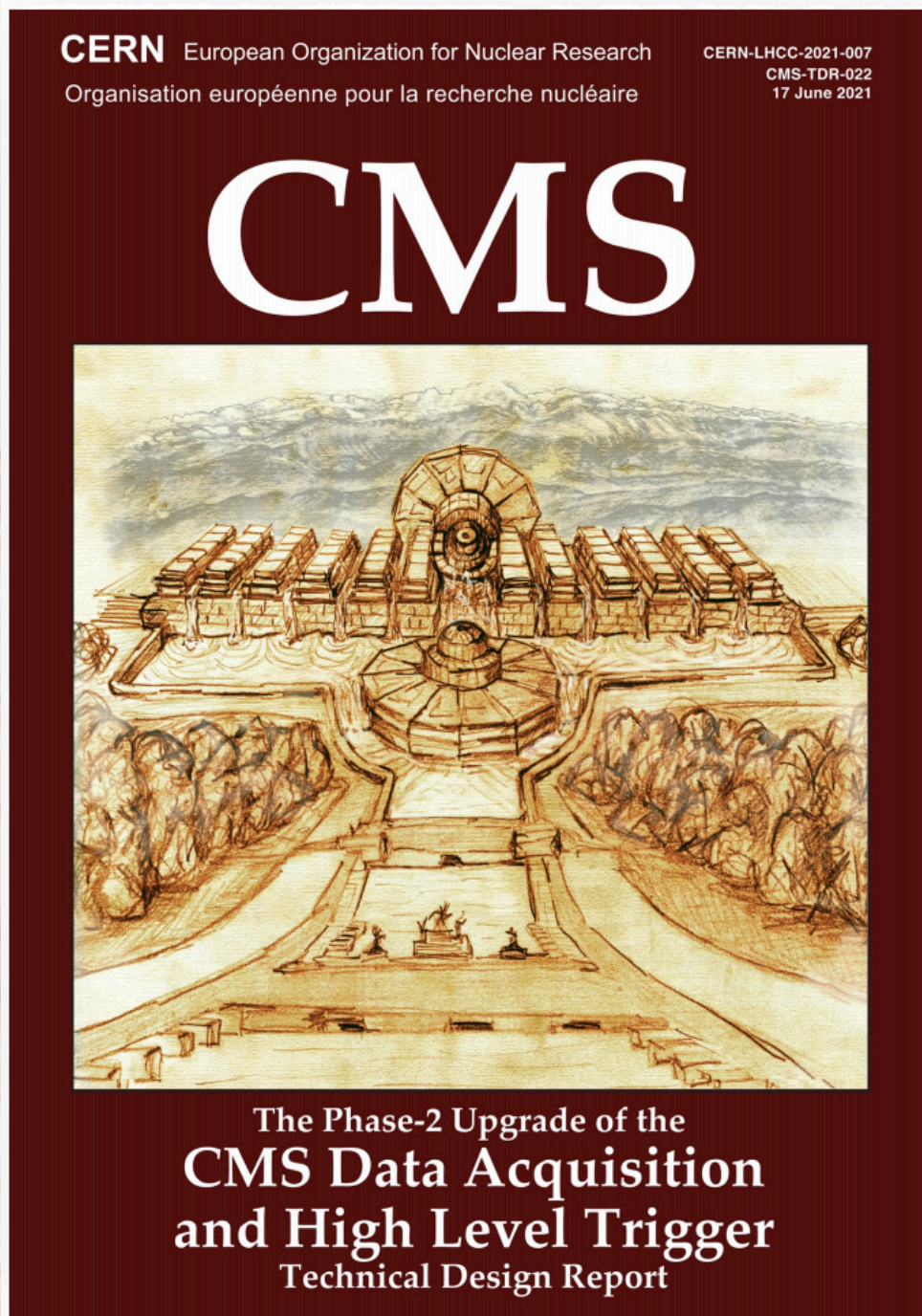

## [HLT/DAQ](#)

- HLT output 7.5 kHz

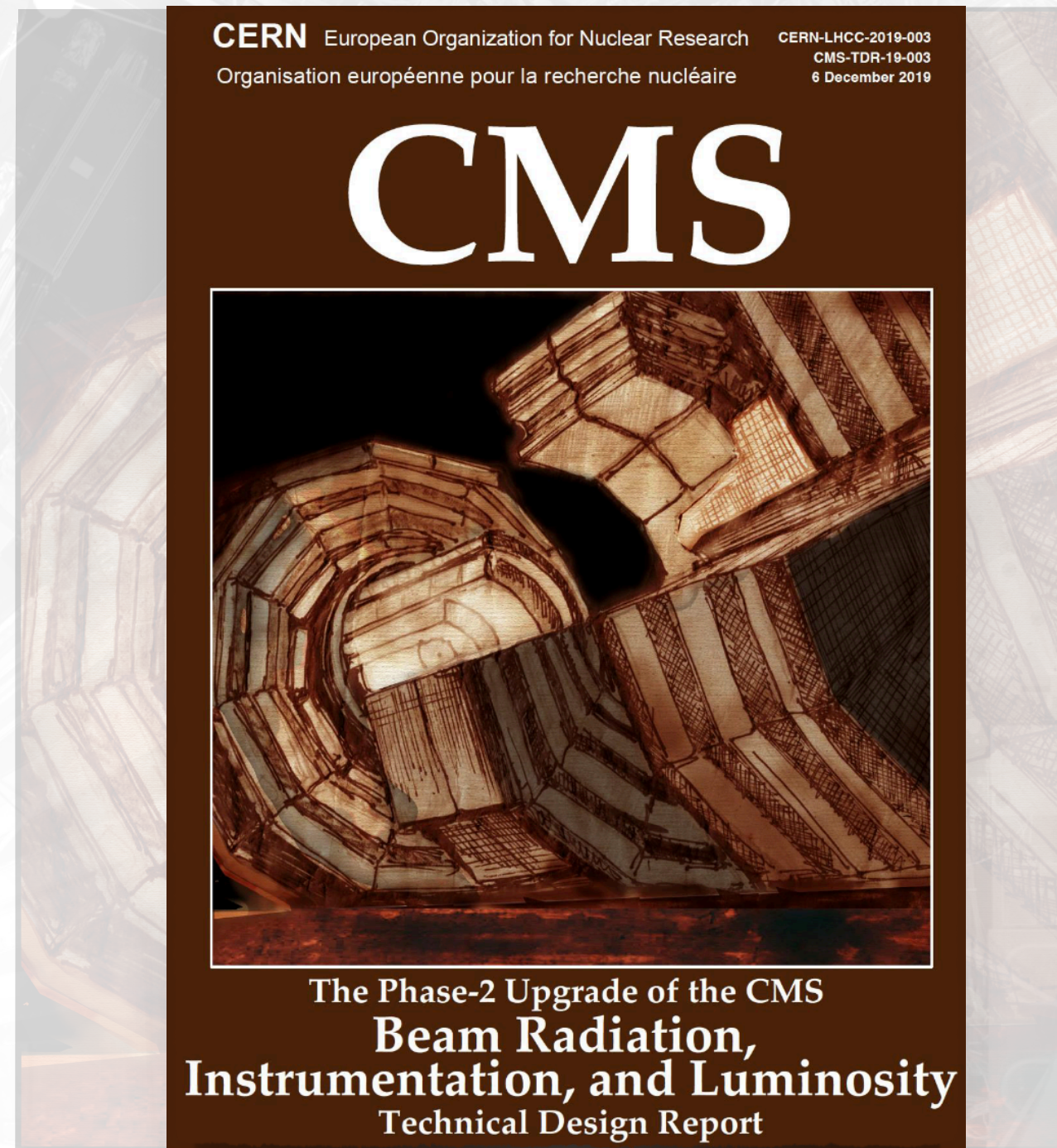

## [Beam Radiation Instr. and Luminosity](#)

- Bunch-by-bunch luminosity measurement: 1% offline, 2% online



# Latest Upgrade TDRs

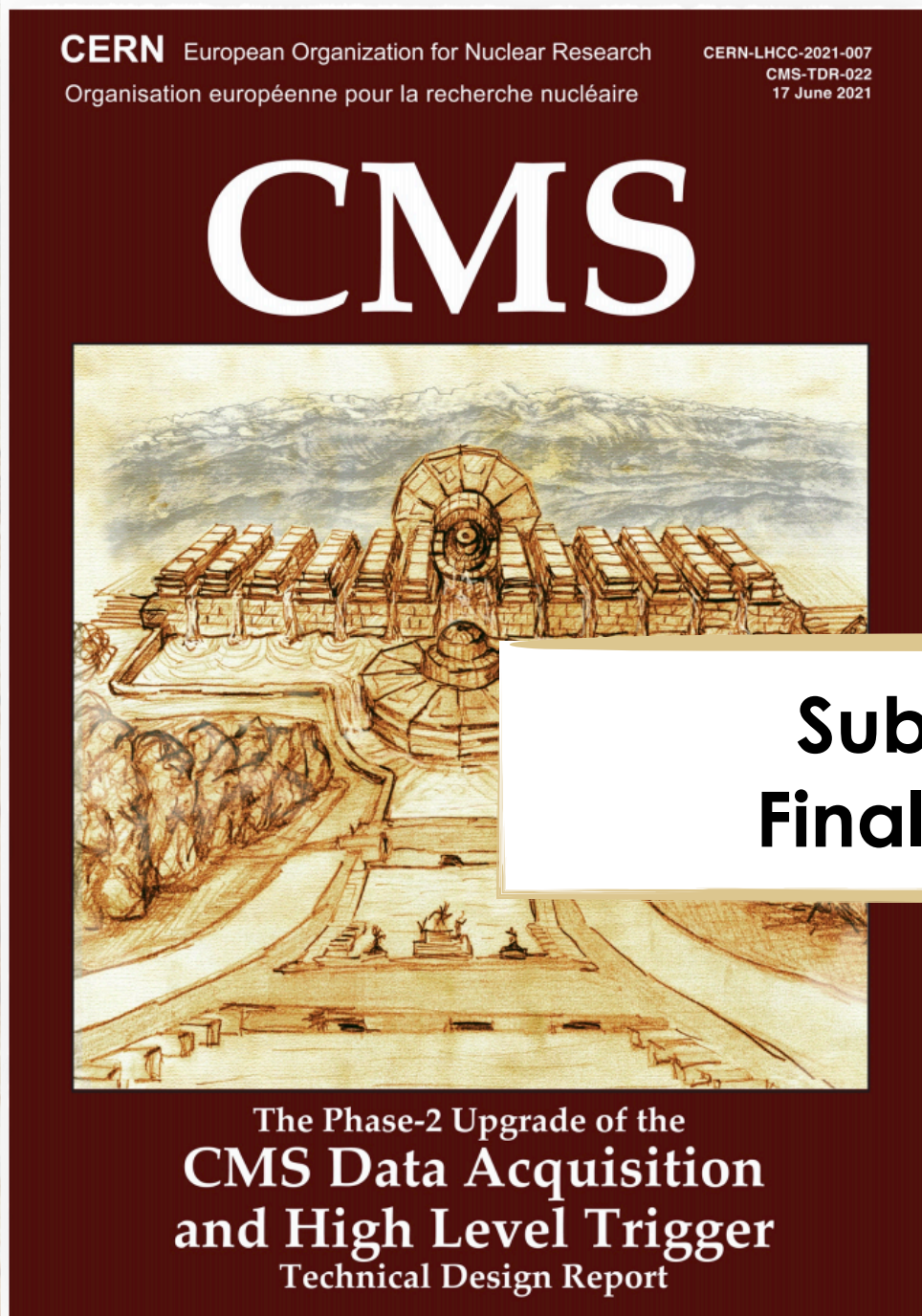

**Submitted mid-end June  
Final Review end of August**



## [HLT/DAQ](#)

- HLT output 7.5 kHz

## [Beam Radiation Instr. and Luminosity](#)

- Bunch-by-bunch luminosity measurement: 1% offline, 2% online



# Phase-2 BRIL Upgrade

- Bunch by bunch luminosity
  - <1% offline
  - <2% real-time

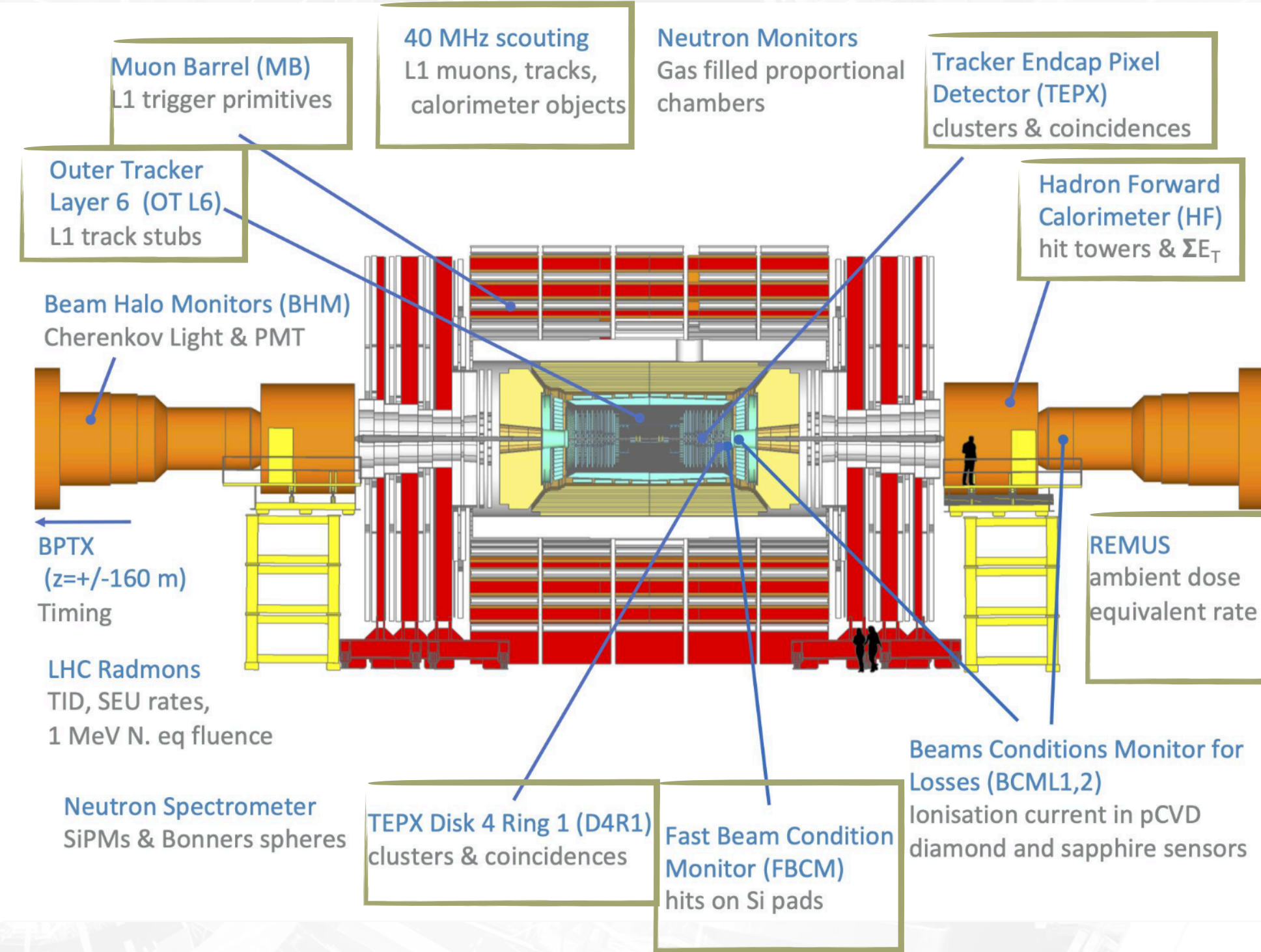



# Phase-2 BRIL Upgrade

- Bunch by bunch luminosity
  - <1% offline
  - <2% real-time

- Online Monitoring of:
  - radiation environment

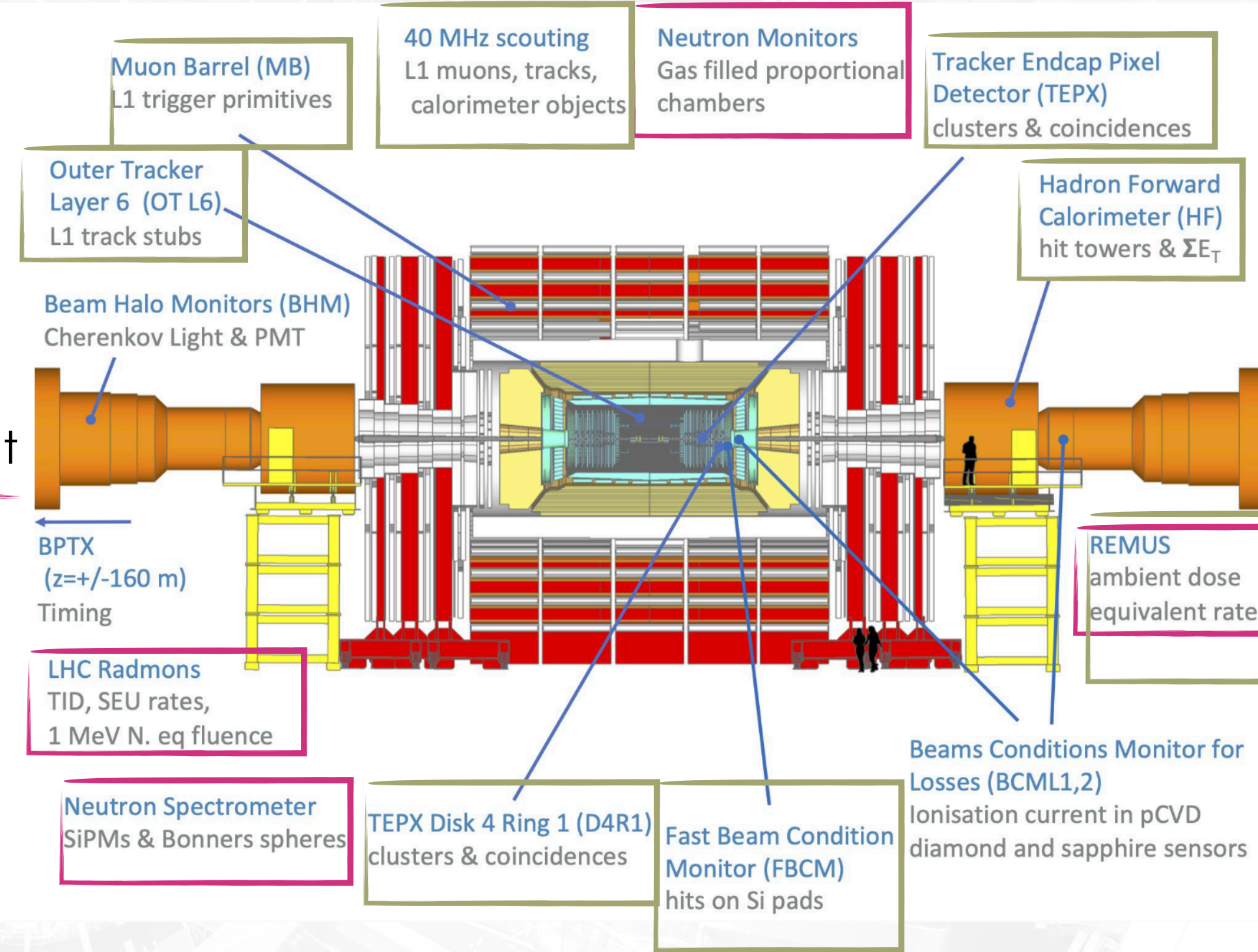



# Phase-2 BRIL Upgrade

- Bunch by bunch luminosity
  - <1% offline
  - <2% real-time

- Online Monitoring of:
  - radiation environment
  - beam induced background

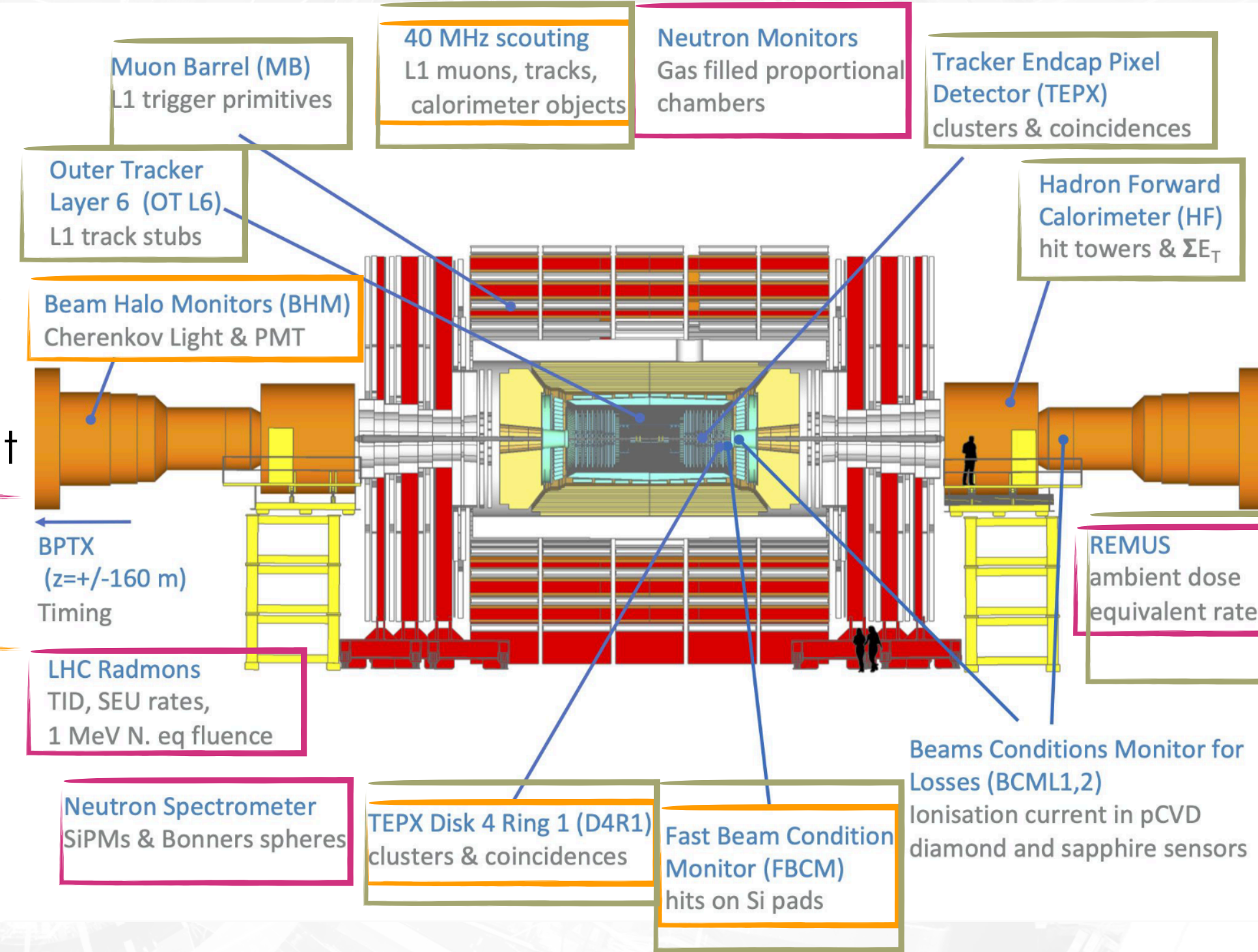



# Phase-2 BRIL Upgrade

- Bunch by bunch luminosity

- <1% offline
  - <2% real-time

- Online Monitoring of:
  - radiation environment

- beam induced background

- Beam abort trigger

- Timing

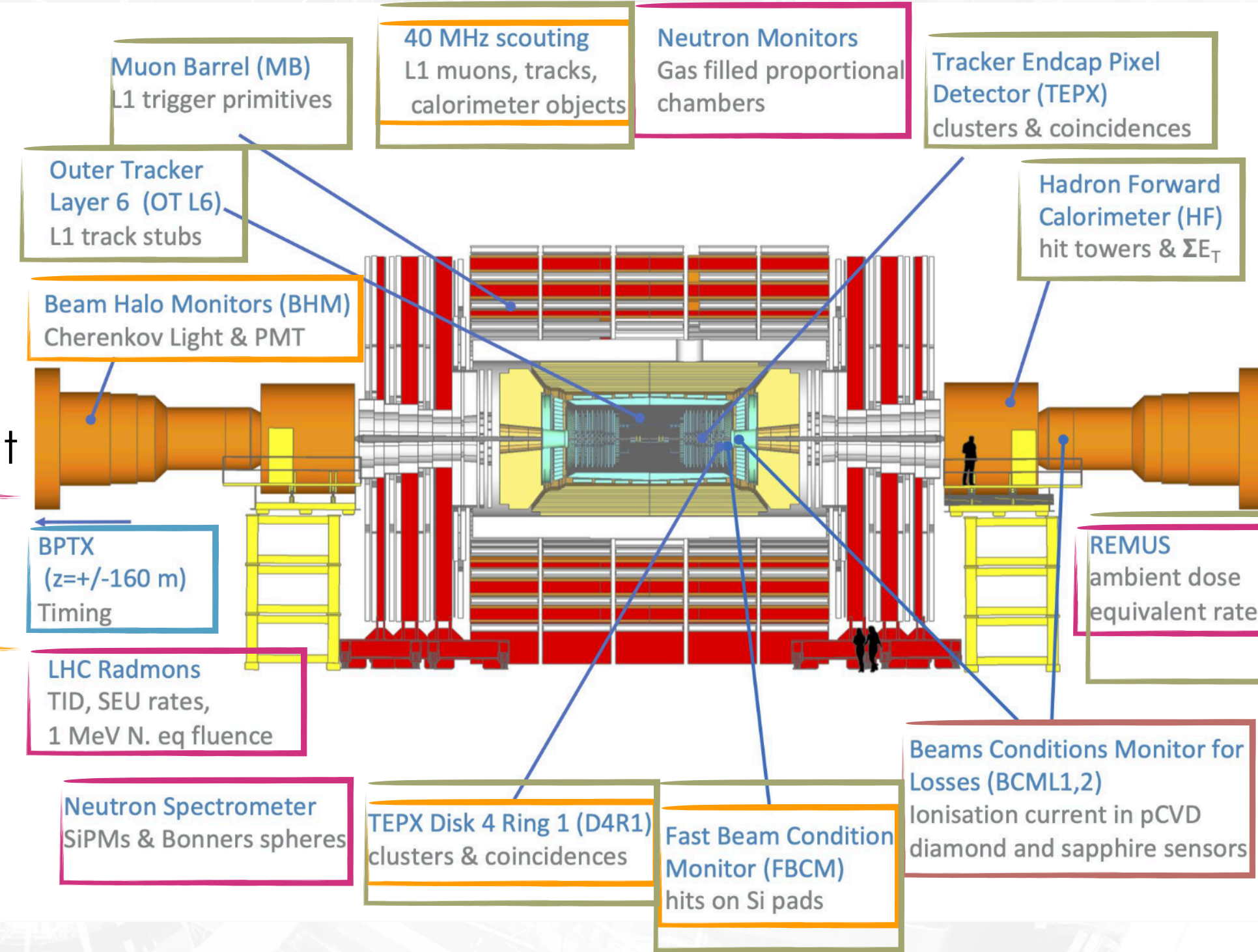



# Phase-2 DAQ baseline

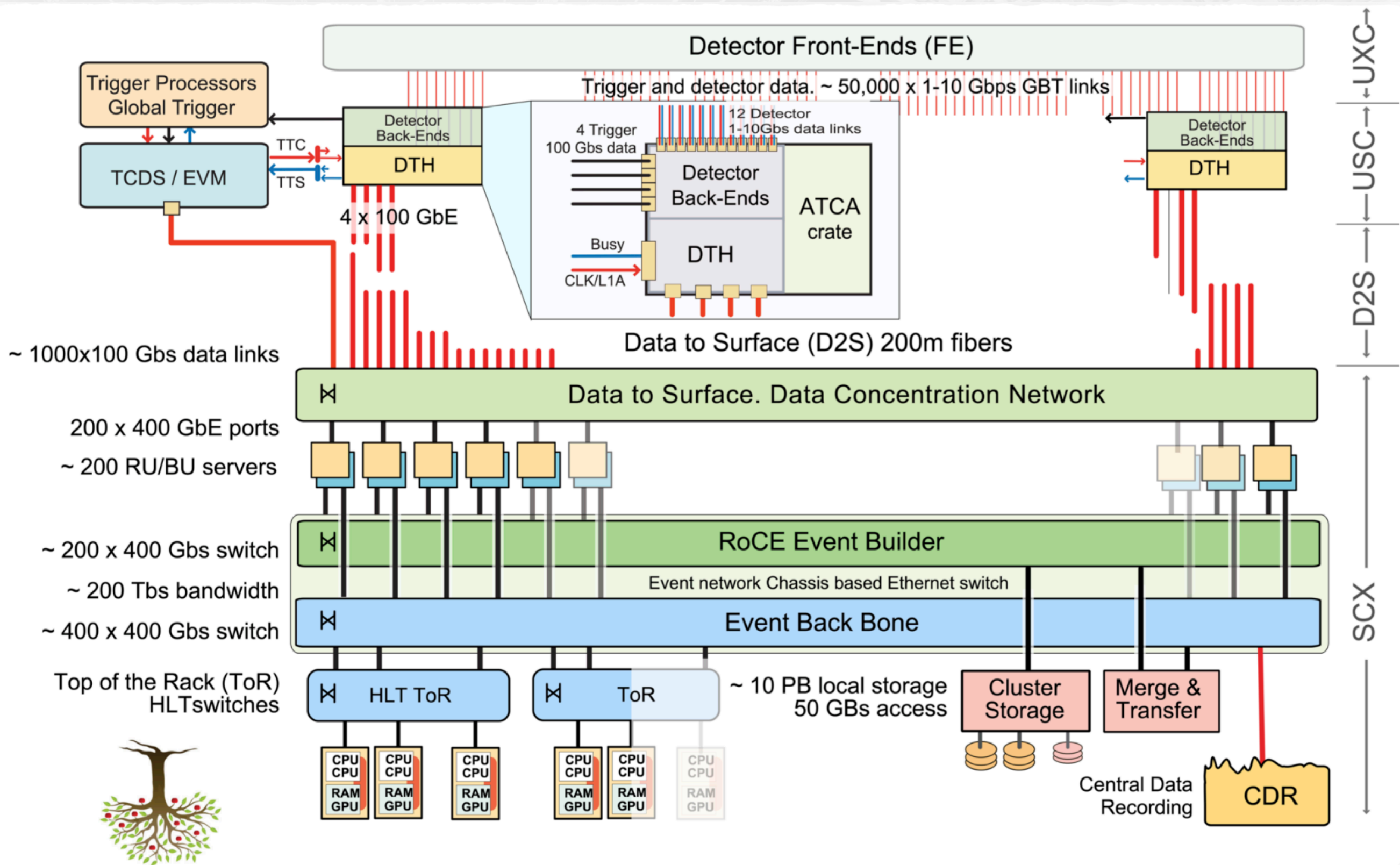



# Phase-2 DAQ Parameters

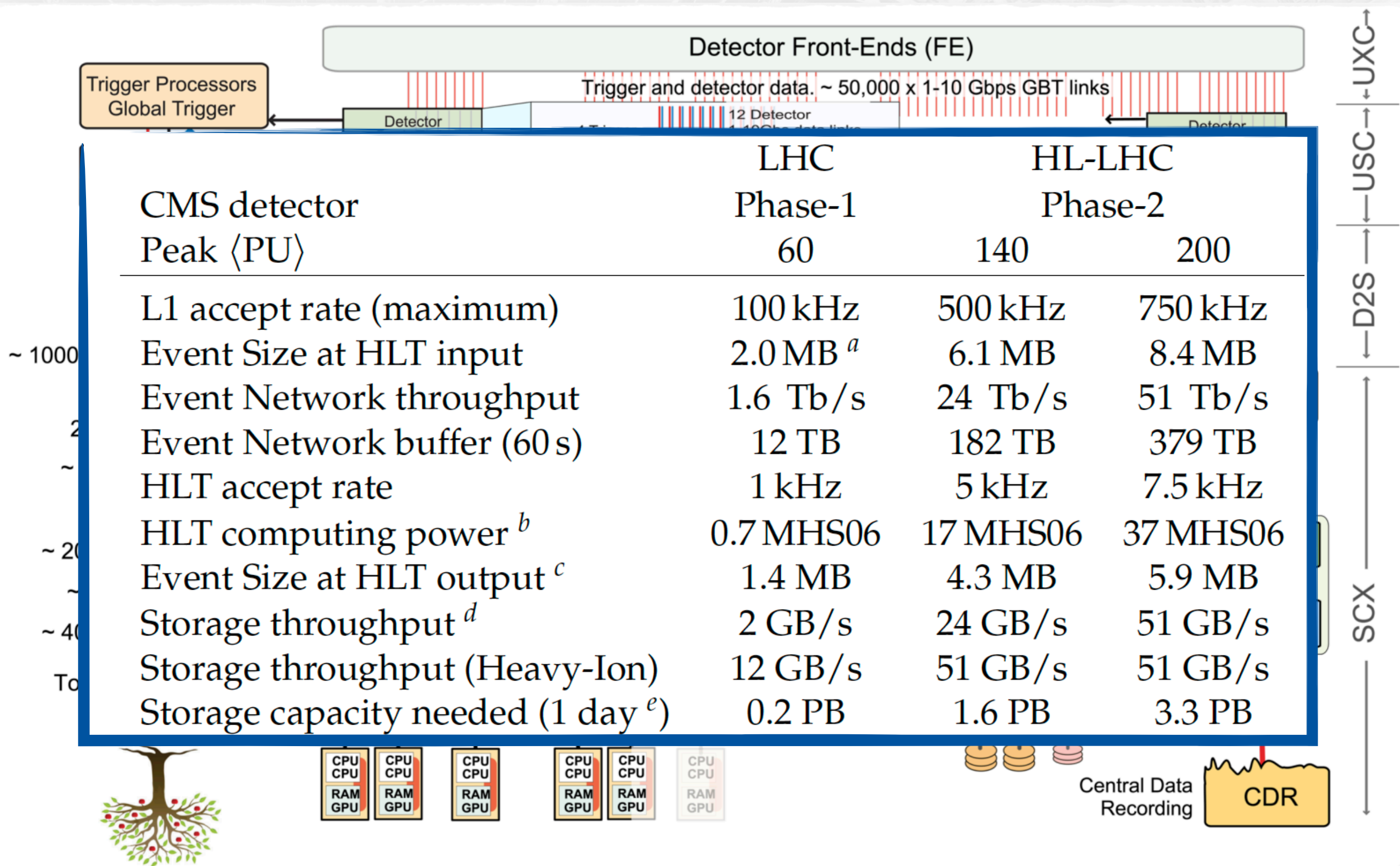



# Phase-2 HLT Realistic Menu

- Implemented in CMSSW
- Operation with **very similar thresholds as in Phase-1**

Trigger type	Phase-1		Phase-2			
	Threshold [GeV]	% rate	L1 seed	Threshold [GeV]	Rate at $\langle \text{PU} \rangle = 140$ [Hz]	Rate at $\langle \text{PU} \rangle = 200$ [Hz]
Single $\mu$	50	3%	TkMu_22	50	$155 \pm 6$	$213 \pm 8$
Single $\mu$ (isol.)	24	14%	TkMu_22	24	$943 \pm 32$	$1111 \pm 29$
Double $\mu$	37, 27	1%	TkMu_15_7	37, 27	$27 \pm 1$	$40 \pm 1$
Double $\mu$ (isol.)	17, 8	2%	TkMu_15_7	17, 8	$113 \pm 11$	$143 \pm 13$
Triple $\mu$	5, 3, 3	0.5%	TkMu_5_3_3	10, 5, 5	$39 \pm 8$	$48 \pm 8$
Single e (isol.)	28	13%	StaEG_51 OR	32 (WP1)	$609 \pm 27$	$1005 \pm 33$
			TkEle_36 OR			
			TkIsoEle_28			
Double e	25, 25	1%	TkEle_25_12 OR	25, 25	$46 \pm 4$	$82 \pm 6$
			StaEG_37_24			
Double e (isol.)	23, 12	1%	TkEle_25_12 OR StaEG_37_24 OR TkIsoEle_22_StaEG_12	23, 12	$52 \pm 5$	$104 \pm 9$
Single $\gamma$	200	1%	StaEG_51	187	$32 \pm 1$	$56 \pm 6$
Single $\gamma$ (isol.)	110, EB only	1%	StaEG_51 OR TkIsoPho_36	108, EB only	$35 \pm 9$	$52 \pm 7$
Double $\gamma$	30, 18	2%	StaEG_37_24 OR TkIsoPho_22_12	30, 23	$123 \pm 12$	$179 \pm 14$
Double $\tau$	35, 35	3%	HPSFFTau_21_21	22, 22	$106 \pm 18^{\dagger}$	$159 \pm 27$
Single jet	500	1%	PuppiJet_230	520	$53 \pm 1$	$76 \pm 1$
$H_T$	1050	1%	PuppiHT_450	1070	$53 \pm 1$	$74 \pm 1$
Missing $p_T$	120	3%	PuppiMET_220	140	$79 \pm 7$	$228 \pm 20$
Multijets	$H_T = 330$	1%	PuppiJet_70_55_	$H_T = 330$	$32 \pm 4$	$48 \pm 5$
with b-tagging	jets = 75, 60, 45, 40		40_40_PuppiHT_328	jets = 75, 60, 45, 40		
<b>Total rate</b>		<b>49%</b>			<b><math>2\,525 \pm 57</math></b>	<b><math>3\,621 \pm 62</math></b>







# Conclusions

- **Long Shutdown 2** on schedule:
  - Successful **pixel** installation
  - **Magnet** cooling down smoothly
- **Successful summer data taking** at PT5:
  - Pixel **alignment**
  - **GPU** integration @ HLT
- **45 New physics results** (LHCP, EPS, SUSY)
  - From Electroweak measurements to BSM searches
- Two new **upgrade TDRs**:
  - **BRIL TDR** : possibility of  $< 1\%$  uncertainty on integrated luminosity
  - **DAQ/HLT TDR** : preserves same trigger thresholds throughout running

***We are excited to re-start data taking beginning of 2022!***