



# LHCb Upgrade Electronics

---

Mailing list:

Go to [simba.cern.ch](http://simba.cern.ch), search for lhcb-upgrade-electronics

Link to upgrade electronics meetings:

<http://lhcb-elec.web.cern.ch/lhcb-elec/html/upgrade.htm>

Meetings in 2010:

9<sup>th</sup> December

Meetings in 2011: more frequent????

Working group on FPGAs in radiation environment:

See mail from Jorgen

If you are interested to join, please contact me

Front-end simulations (Tomasz Skwarnicki):

MC launched for  $L = 2 \times 10^{33}$

Propose meeting end October to discuss next steps

# ECS with GBT + GBT-SCA

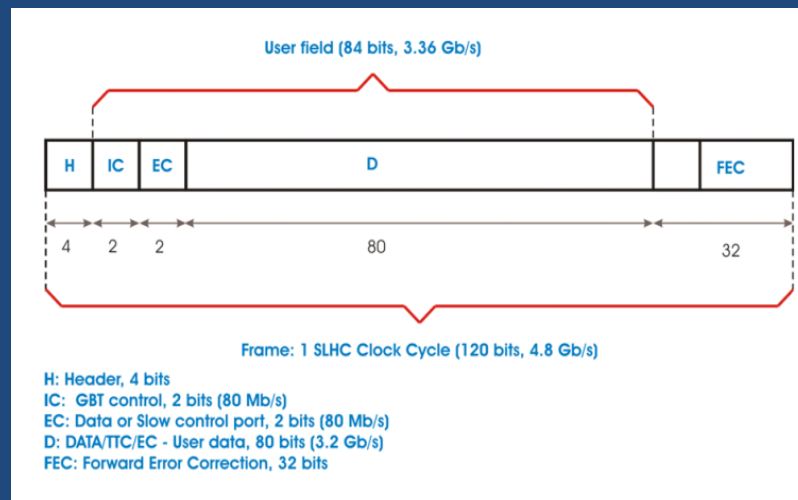
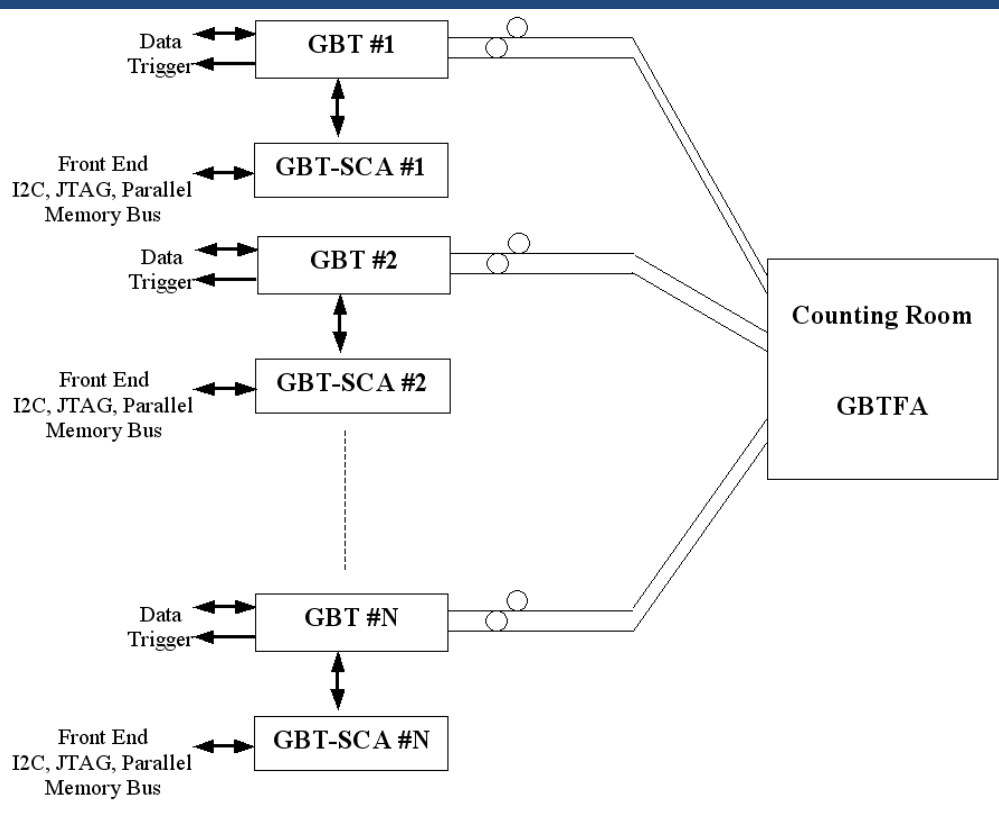

NB: More GBT-SCAs can be connected to a GBT  
 -> sacrifice 2 bits of the 80 GBT-SCA

From Kostas Kloukinas

# GBT-SCA

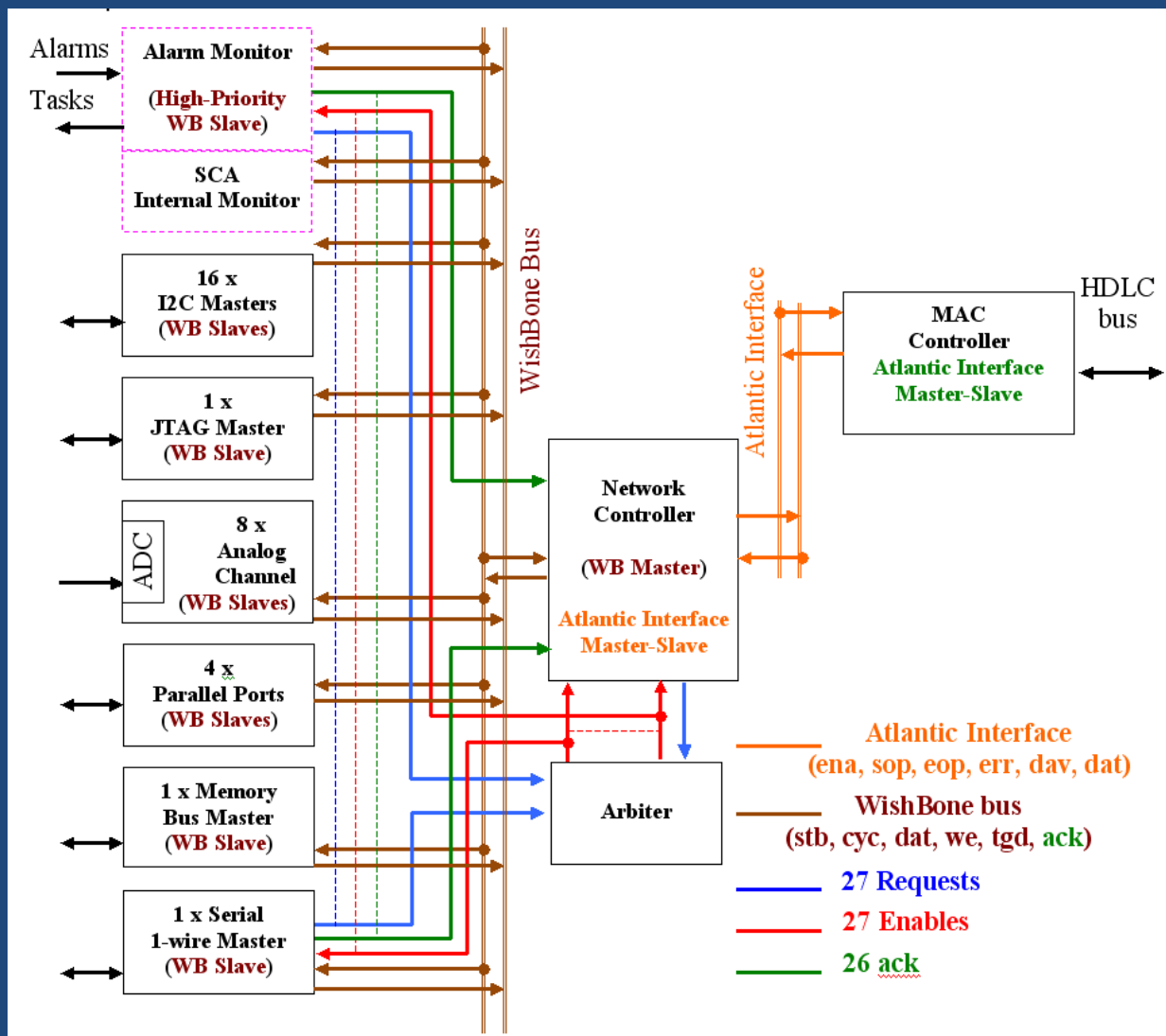

and SPI interface

From Kostas Kloukinas

# FPGA irradiations

---

Talk from Ray Mountain later

Future:

More irradiations? Yes, we should

Combine knowledge with CMS HCAL

– they will use the ACTEL IGLOO family (low power)

..... Is it OK for us?

..... more expensive!

# Architecture

