



Wakefield Damping of a Distributed Coupling LINAC for CLIC

Evan Ericson, Alexej Grudiev

International Workshop on Breakdown Science and High Gradient Technology (16-19 May, 2022)

Wakefield Damping of a Distributed Coupling LINAC for CLIC

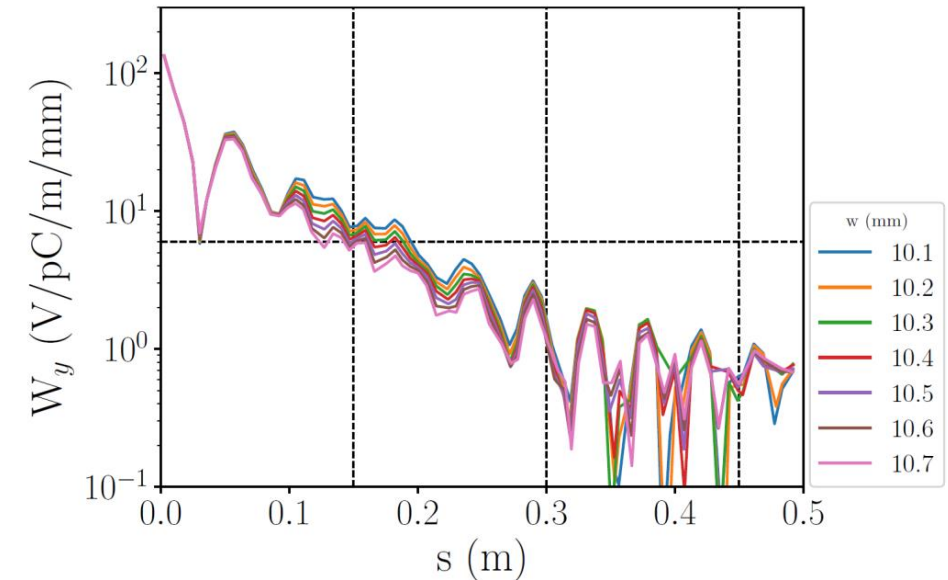
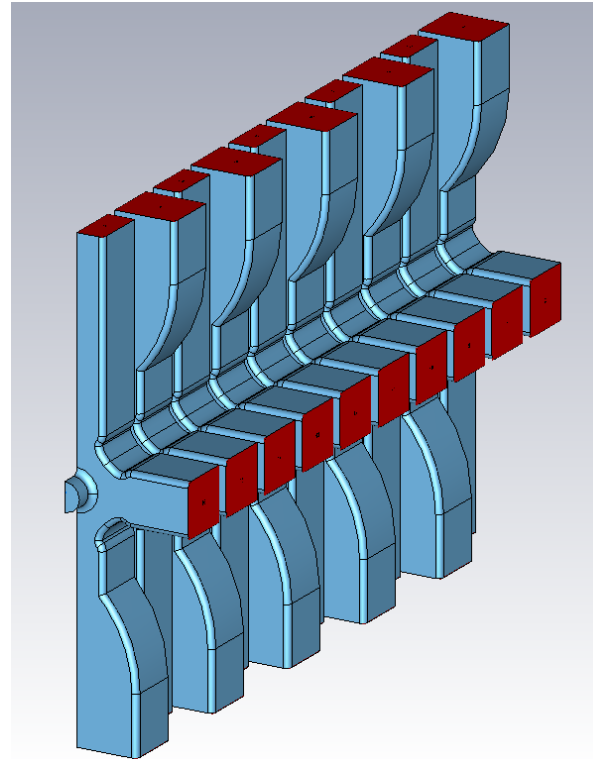
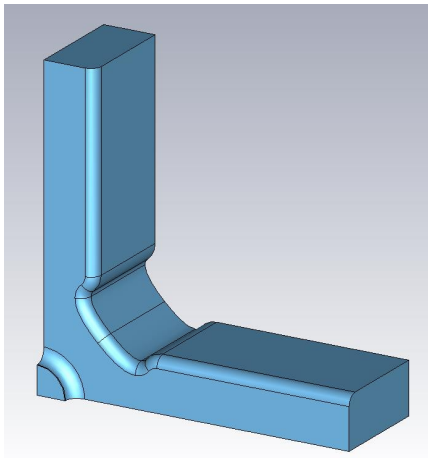

Goal: Modify CLIC-G* structure to make a distributed coupling structure that satisfies transverse wakefield damping requirement

Travelling wave to standing wave cell

Adjusted cell length for π phase advance and outer radius for operating frequency

- Optimize iris shape for surface fields and RF performance

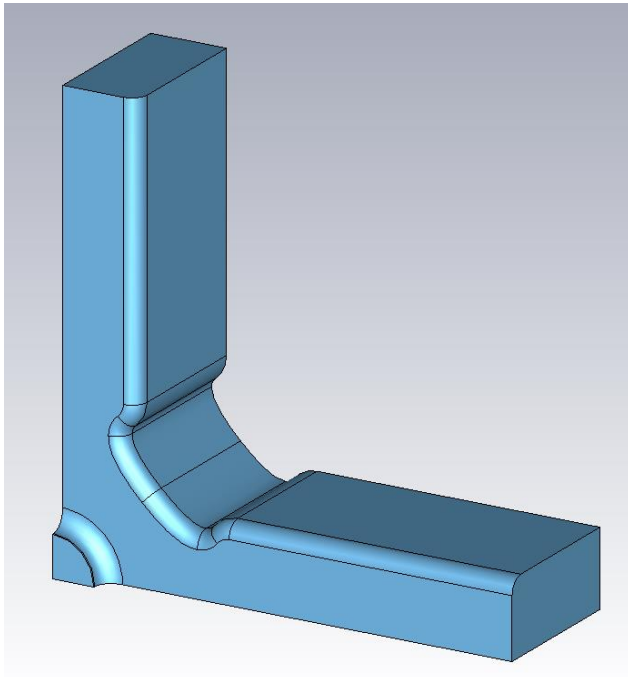

4 design options:

Opt0 – non-optimized SW cell

Opt1 – optimize E_s/E_a for high gradient performance

Opt2 – optimize R for efficiency (same E_s/E_a as TW)

Opt3 – optimize S_c/E_a^2 for high gradient performance

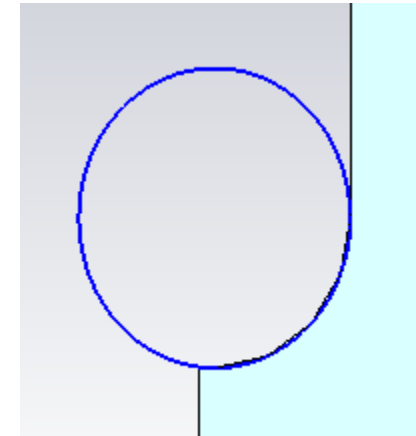

Comparing cell designs I

	unit	TW	SW – Opt0	SW – Opt1	SW – Opt2	SW – Opt3
Iris thickness	mm	1.333	1.333	2.6	2.3	2.35
Iris ellipticity		1.153	1.102	2.400	1.600	1.179
f_0	GHz	11.9952	11.9947	11.9943	11.9943	11.9939
Q		5,843	7,140	6,930	6,940	6,920
R/Q	Ohm/m	16,515	11,219	10,980	11,208	11,368
R	MOhm/m	96.49	80.10	76.09	77.78	78.67
E_s/E_a		1.98	2.486	1.79	1.98	2.11
H_s/E_a	mA/V	3.73	4.432	4.67	4.60	4.59
S_c/E_a^2	mA/V	0.33	0.296	0.34	0.33	0.33

Comparing cell designs II

	unit	TW	SW – Opt0	SW – Opt1	SW – Opt2	SW – Opt3	limit
N		26+2	18	18	18	18	
L	mm	230	225	225	225	225	
$E_{acc}^{load\ avg}$	MV/m	100	100	100	100	100	
V_{acc}	MV	23.0	22.5	22.5	22.5	22.5	
P_{diss}	MW	33.17	28.09	29.57	28.93	28.60	
P_b	MW	27.232	26.64	26.64	26.64	26.64	
P_0	MW	60.40	54.73	56.21	55.57	55.24	
T	ns		64.27	63.40	63.05	62.65	
$E_{acc}^{UL\ avg}$	MV/m	120.00	139.58	137.87	138.60	138.98	
t_{fill}	ns	62.60	80.99	81.92	80.61	79.65	
t_p	ns	218.60	236.99	237.92	236.61	235.65	
total RF-beam efficiency	%	27.80	32.04	31.08	31.61	31.93	
E_a in middle cell	MV/m	105	100	100	100	100	
E_s	MV/m	232	248.60	179.00	198.00	211.00	240
H_s	MA/m	0.39	0.44	0.47	0.46	0.46	
ΔT - pessimistic	K	49.70	42.06	46.79	45.27	44.98	40
S_c scaled to 200 ns	MW/mm ²	5.67	3.13	3.60	3.49	3.49	4

Structures whose wakes were evaluated

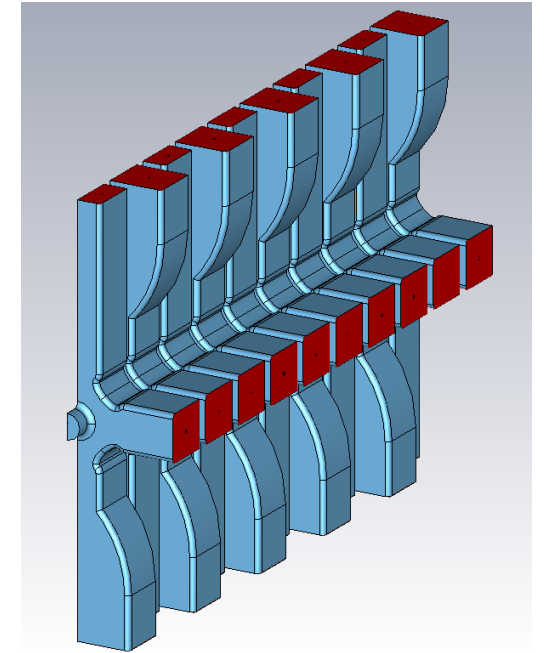
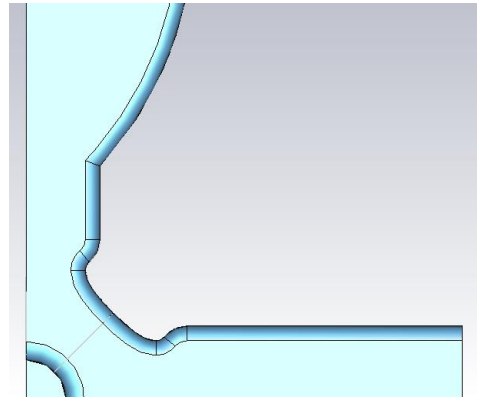
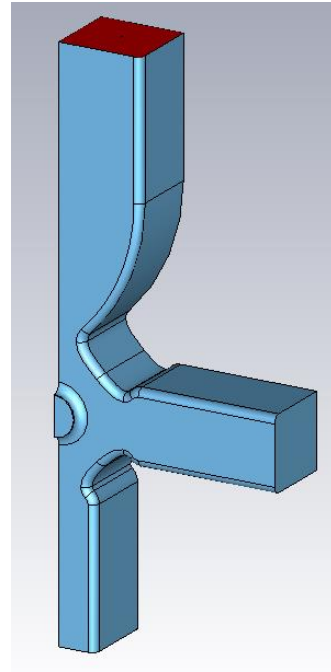
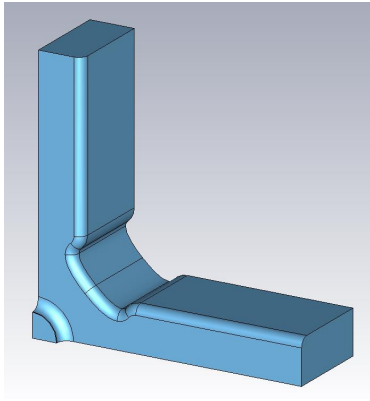

- No power input

- Power input reduces damping
- Asymmetric cell

- Provides damping and input power

- Alternating input couplers mitigates kicks due to asymmetry

Wakefields of distributed coupling structure

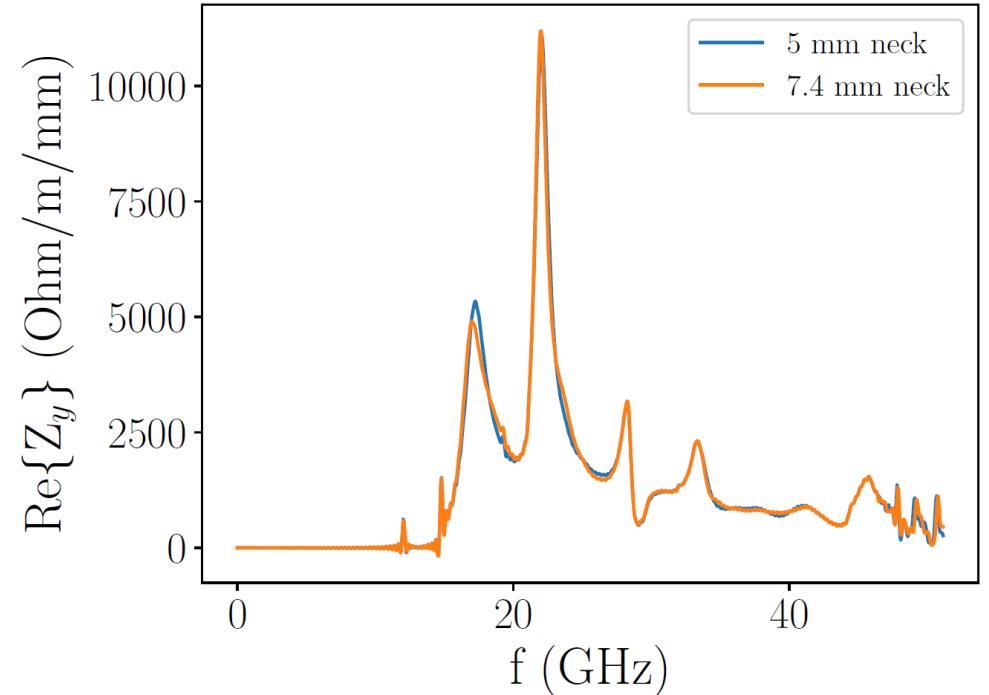
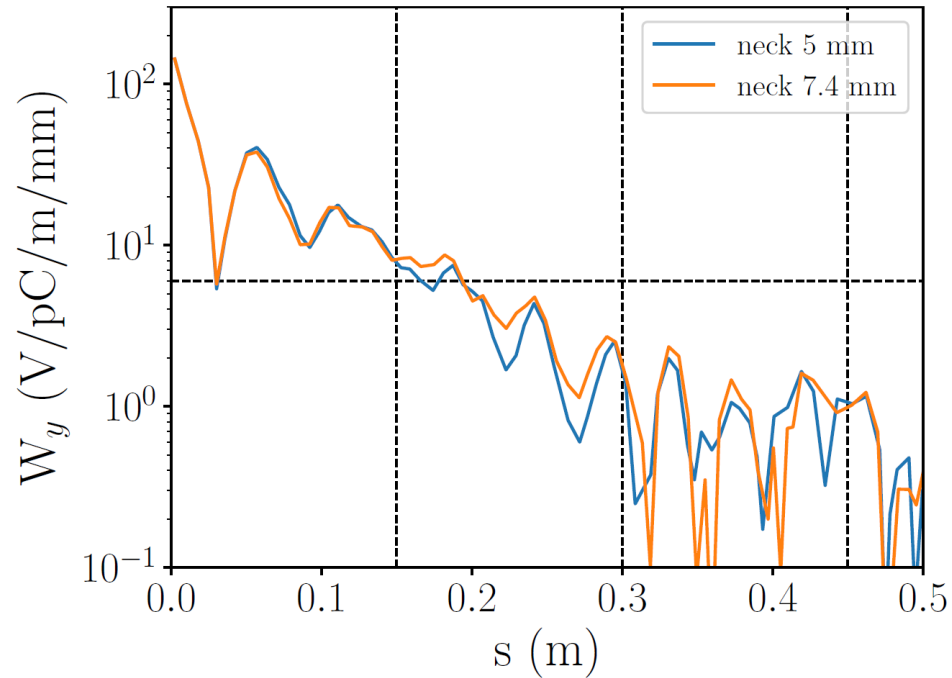

- Insufficient damping at 2nd bunch position (0.15 m)
- Impedance peaks at 17, 22 GHz

Impedance fitting

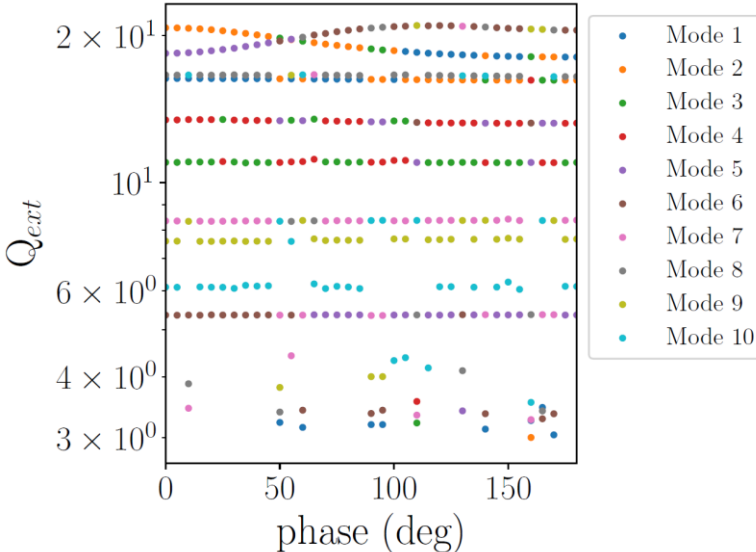
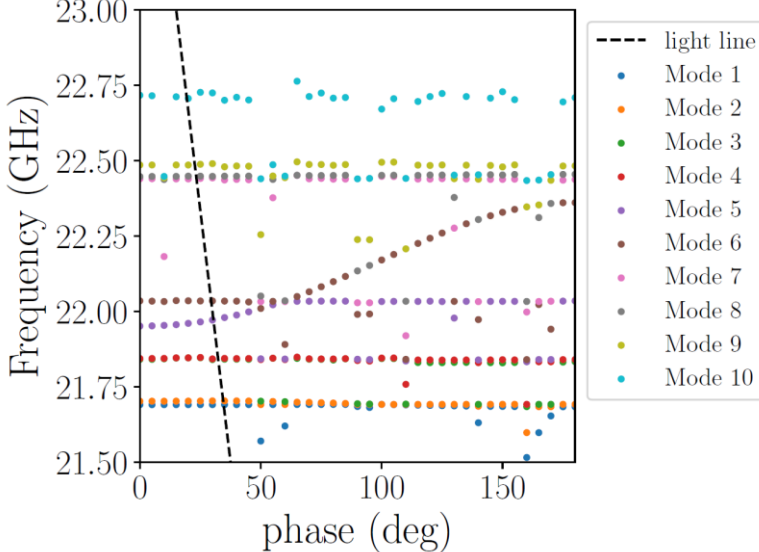
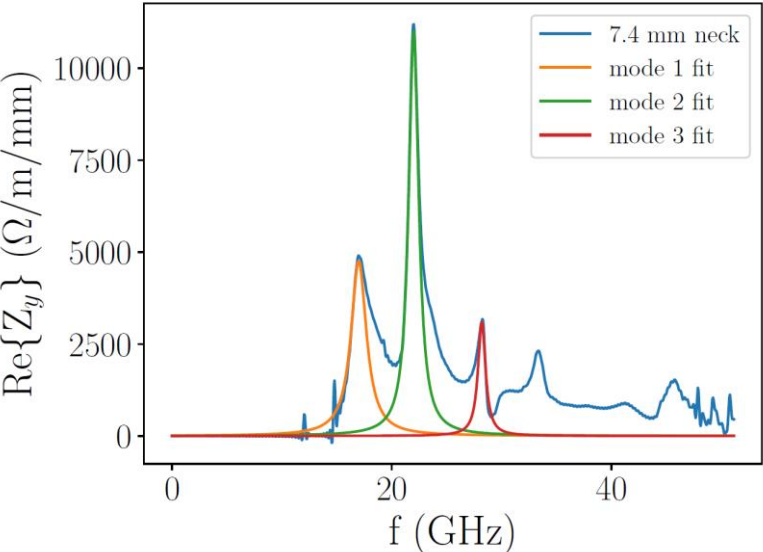

	Mode 1	Mode 2	Mode 3
f (GHz)	17	22	28.2
Q_{ext}	10	20	34
$Z = R/2$	9,500	22,000	6,200

Which mode contributes most to the wakepotential at the 2nd bunch position?

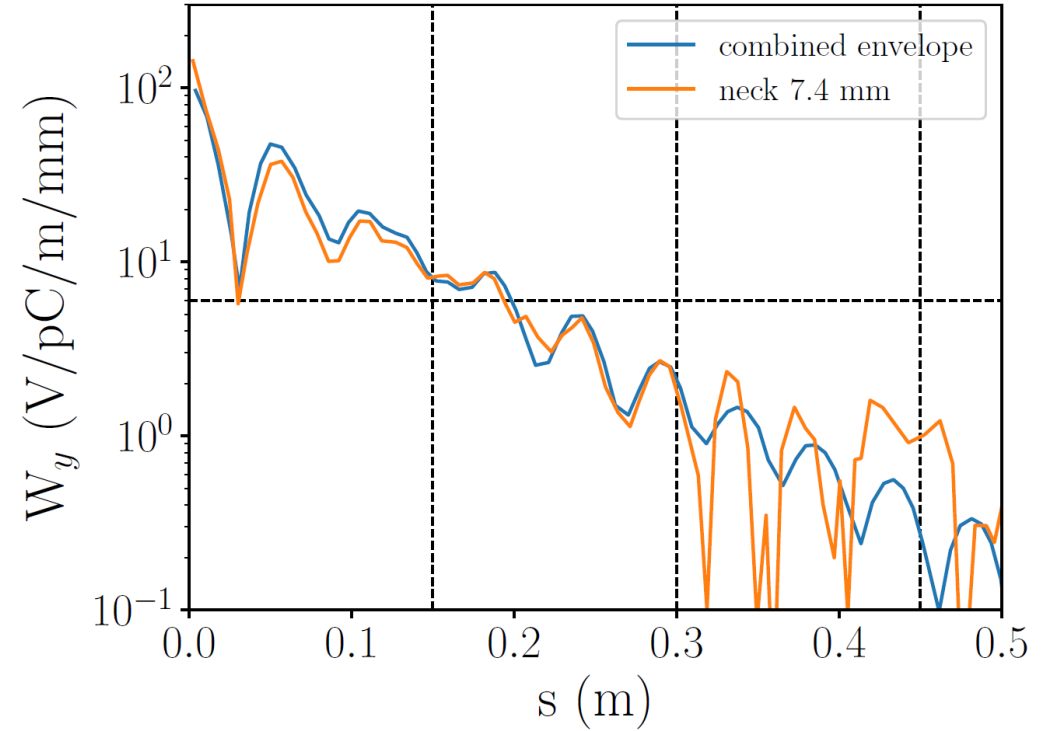
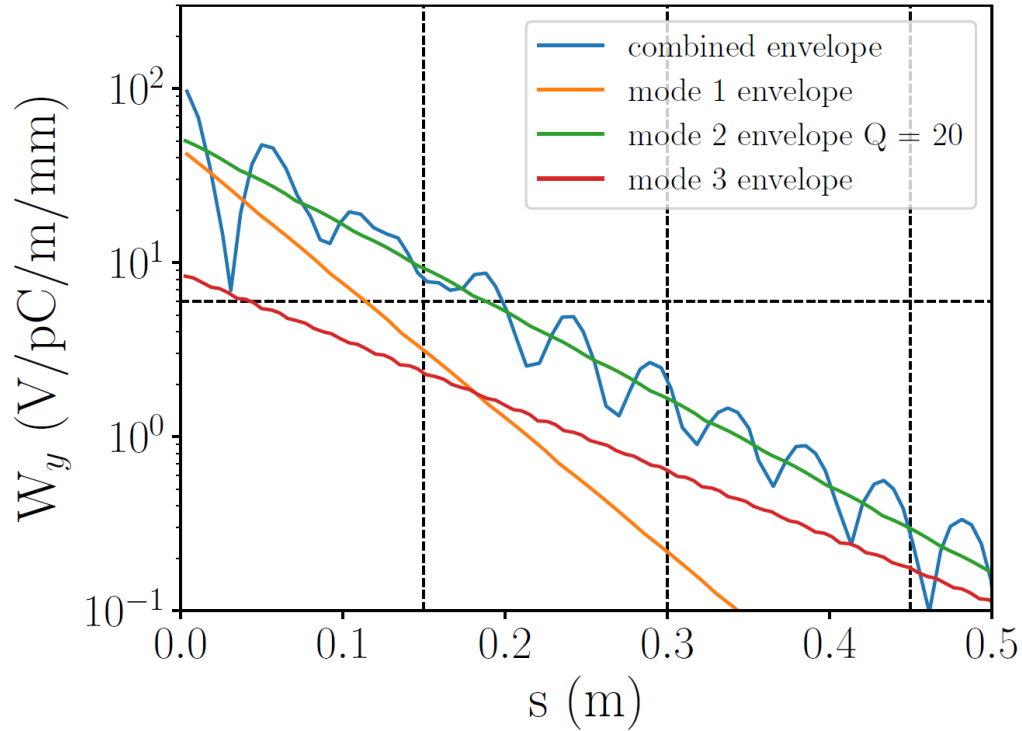

- Mode 2 (22 GHz) dominates wakepotential at position of 2nd bunch

Reducing Q of mode 2 to 15

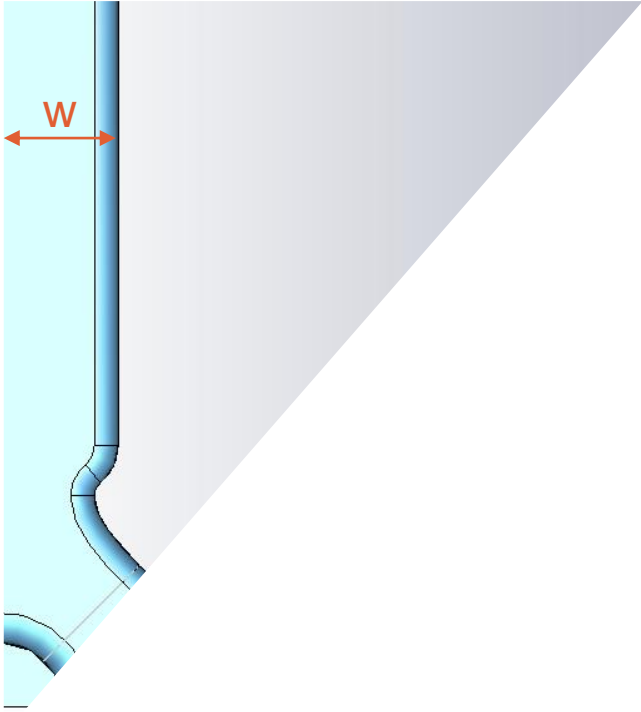
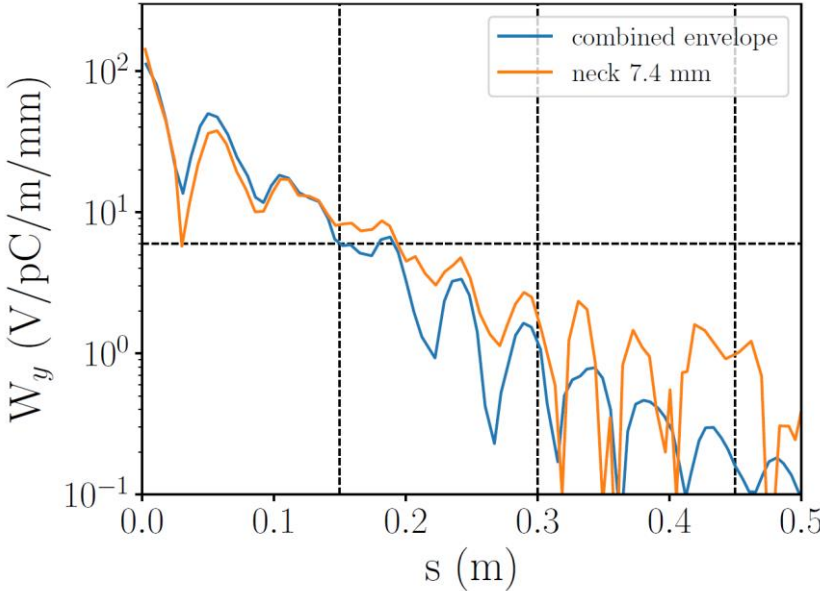
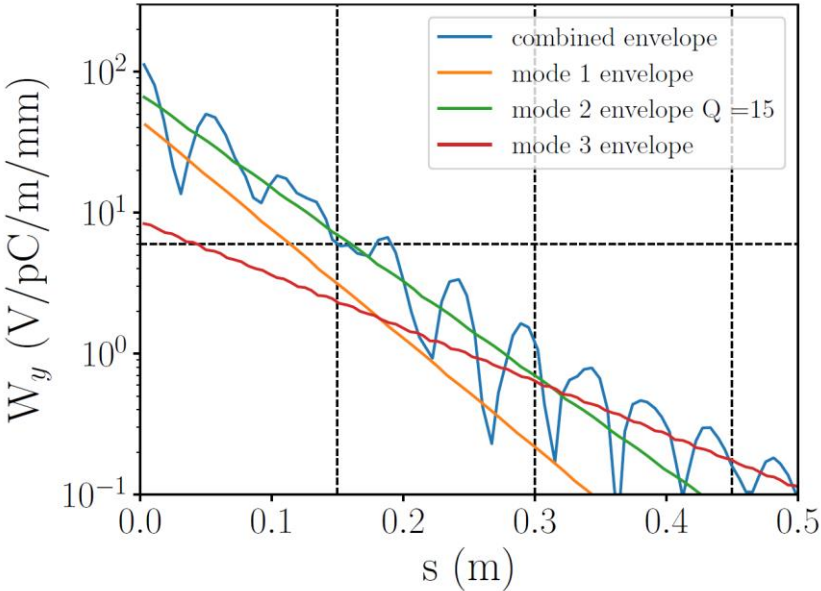

- Change HOM waveguide-to-cell aperture or waveguide width to reduce Q
- Modifying waveguide width keeps cell symmetric in vicinity of beam

Varying waveguide width to increase damping

