



# The CHUV-CERN collaboration to design and construct a high-energy electron FLASH therapy facility

- A very hot topic in radiation oncology is so-called FLASH therapy which involves delivering an entire radiation treatment in a few hundred ms or less, as opposed to minutes, and in one or few fractions.
- This fast delivery can reduce toxicity to healthy tissue while maintaining tumor control expanding the parameter space for treatment – more in a moment.
- Another trend in radiation oncology is a renewed interest in VHEE (Very High Energy Electron) therapy.
- In parallel universe, major developments in accelerator technology have occurred in linear collider projects, relevant for this story, CLIC...



# Introduction



I will describe to you today a project which draws together these different themes, in a collaboration between CHUV (Centre Hospitalier Universitaire Vaudoise, Lausanne Hospital) and CERN to build a clinical FLASH-capable facility for treatment of large, deep-seated tumors using high-energy, 100 MeV-range, electrons accelerated with CLIC-developed technology.



# Outline



- Some history and the CHUV clinical FLASH program – I will use slides from Prof. Jean Bourhis
- The CHUV-CERN collaboration
- Brief CLIC introduction
- Introduction to the accelerator part of the facility

## Historical perspective

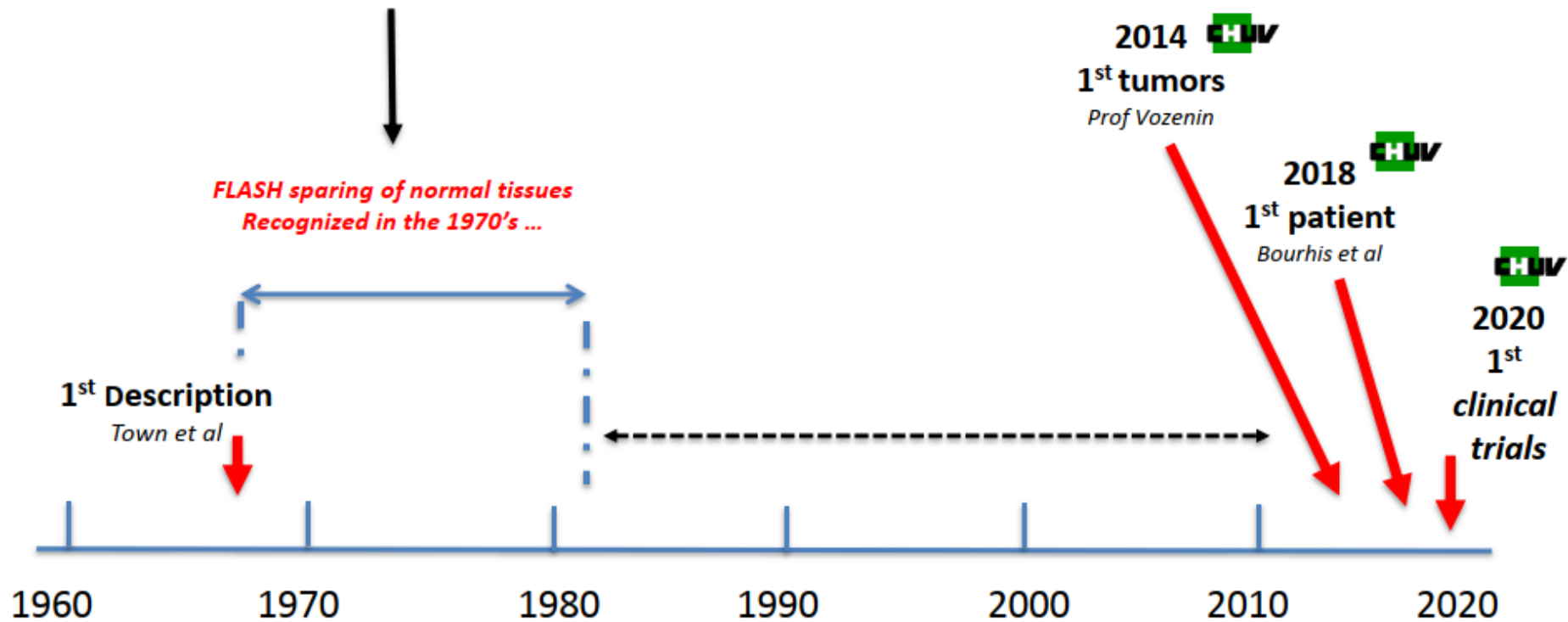

Until 1982 :

Dose for inducing tail necrosis in mice

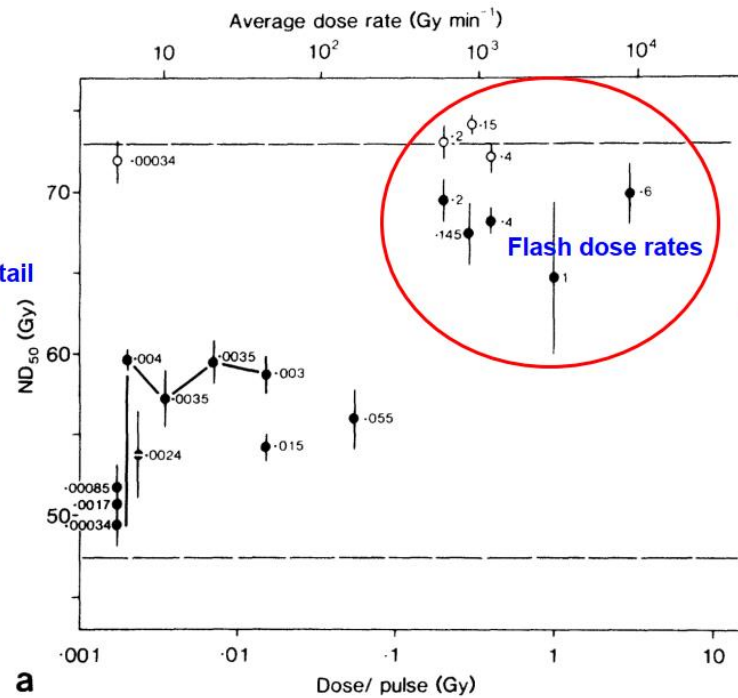

Jolyon H. Hendry  
1982

FLASH sparing effect on normal tissues was recognized

2014 Re-discovery ...

- 1) Sparing normal tissues
- 2) No sparing of tumors



Favaudon & Vozenin

RESEARCH HIGHLIGHTS

IN BRIEF

RADIOTHERAPY  
FLASHing tumours

A new study in mice suggests that radiation delivered in short pulses at ultrahigh dose rates (FLASH) is as effective against lung tumours as conventional protracted single lower dose rates and has fewer side effects. Using both orthotopic lung tumours in immunocompetent mice and human lung tumour xenografts in nude mice, Favaudon *et al.* showed that FLASH irradiation caused less lung fibrogenesis and less apoptosis in normal tissue than conventional radiation. Although this technique was only tested in one tumour type, it suggests that delivery methods are crucial to minimizing radiation treatment side effects, and it has implications for therapeutic protocols.

**ORIGINAL RESEARCH PAPER** Favaudon, V. *et al.* Ultrahigh dose-rate FLASH irradiation increases the differential response between normal and tumor tissue in mice. *Sci. Transl. Med.* **6**, 245ra93 (2014)

## Illustration of the Flash-RT effect in pig : A major decrease of radiation side effects



*Vozenin et al  
Clin Cancer Res  
2018*



Original Article

### Treatment of a first patient with FLASH-radiotherapy

Jean Bourhis<sup>a,b,\*</sup>, Wendy Jeanneret Sozzi<sup>a</sup>, Patrik Gonçalves Jorge<sup>a,b,c</sup>, Olivier Gaide<sup>d</sup>, Claude Bailat<sup>c</sup>, Frédéric Duclos<sup>a</sup>, David Patin<sup>a</sup>, Mahmut Ozsahin<sup>a</sup>, François Bochud<sup>c</sup>, Jean-François Germond<sup>c</sup>, Raphaël Moeckli<sup>c,1</sup>, Marie-Catherine Vozenin<sup>a,b,1</sup>

<sup>a</sup> Department of Radiation Oncology, Lausanne University Hospital and University of Lausanne; <sup>b</sup> Radiation Oncology Laboratory, Department of Radiation Oncology, Lausanne University Hospital and University of Lausanne; <sup>c</sup> Institute of Radiation Physics, Lausanne University Hospital and University of Lausanne; and <sup>d</sup> Department of Dermatology, Lausanne University Hospital and University of Lausanne, Switzerland



**Fig. 1.** Temporal evolution of the treated lesion: (a) before treatment; the limits of the PTV are delineated in black; (b) at 3 weeks, at the peak of skin reactions (grade 1 epithelitis NCI-CTCAE v 5.0); (c) at 5 months.

## First human patient – skin cancer treated with 10 MeV-range electrons

### Conditions to obtain or miss the FLASH effect

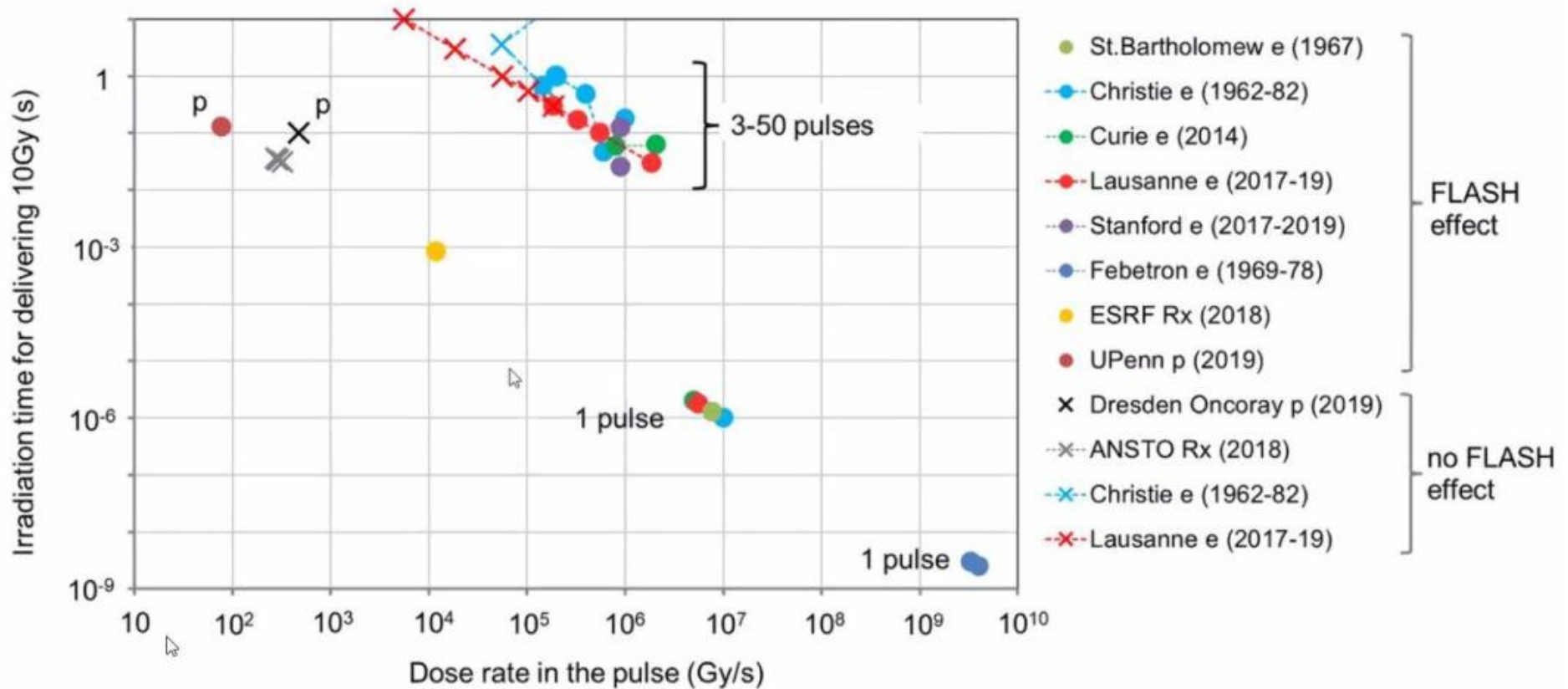

Apparently no dependence on type of radiation – what matters is time structure.

JF Germond, CHUV

## Transfert clinique au CHUV (I)

### FLASH-Mobetron

*Only for superficial skin cancers*

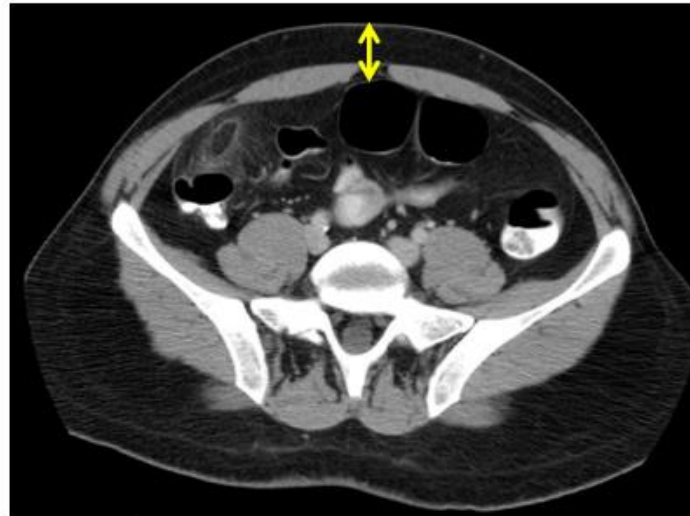

Press release  
Lausanne, Switzerland & Sunnyvale, USA, June 18 2020 1'

### IntraOp and Lausanne University Hospital Announce Collaboration in FLASH

A collaborative R&D agreement will advance FLASH radiotherapy for cancer patients

The Lausanne University Hospital (CHUV) and IntraOp Medical Corporation have announced a research and development collaboration to accelerate the development of FLASH radiotherapy toward first human trials.



## Transfert clinique @ CHUV (II) : intra-operative FLASH-THERAPY

*With  
Pr Simon,  
Pr Demartines,  
Pr Mathevet*

*For cancers not amenable to  
A complete resection*



t-

## What about large tumor volumes and deep seated tumors ?

- **Unmet clinical need** : this is where we have most of the tumor failures ...
- **So far no FLASH** pre-clinical data mimicking these clinical situations
- **No FLASH** irradiating device is currently **available** : technical challenges
- **FLASH characteristics may not help for its use in such large volumes ?**



# The CHUV-CERN collaboration



- From a few coincidences then follow up discussions (a story for another day) CHUV and CERN realized that electron linac technology developed for CLIC could be the basis for a facility for treating large, deep-seated tumors in FLASH timescales – extending CHUV’s clinical translation program.
- An extremely dynamic collaboration started in early 2019 to make a conceptual design of such a facility. This design is now done, feasibility OK and we have a good idea of the critical areas.
- CHUV succeeded in finding a donor to fund the construction of the facility.
- The project officially started on 1 September, and ramp-up – as a collaboration, at CHUV and at CERN – is now underway.
- Participation of an industrial partner is planned and investigation and discussions are underway.



Working title:

## The DEFT (Deep Electron FLASH Therapy) facility

Deft, *adjective*

neatly skilful and quick in one's movements.

"a deft piece of footwork"

demonstrating skill and cleverness.

"the script was both deft and literate"

Very broadly, the DEFT accelerator is a combination of the CLIC main linac, XBoxes, CTF2,3 and CLEAR. It draws on both simulation tools and hardware developed for CLIC,

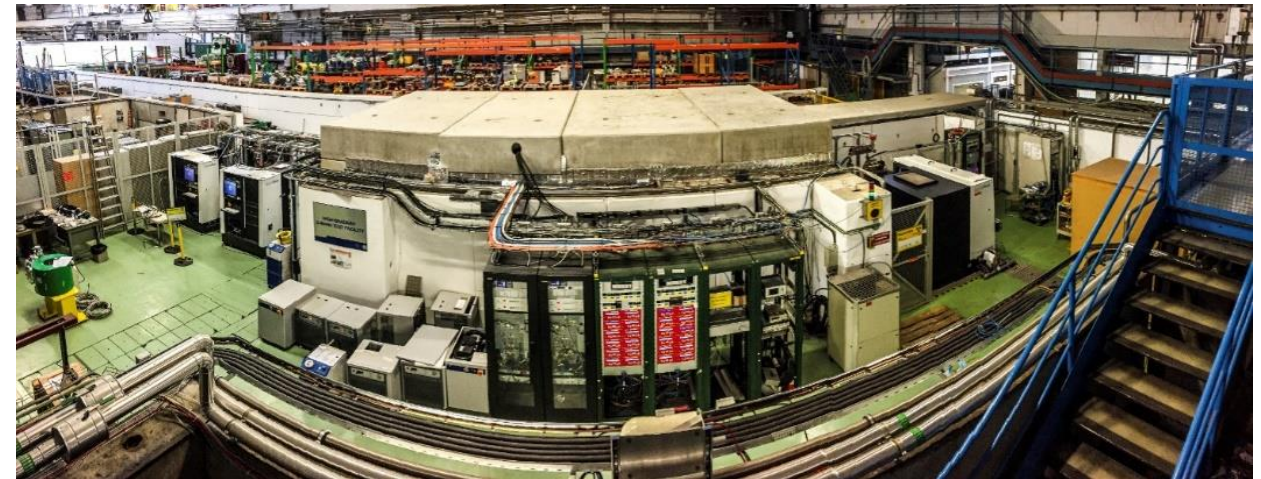
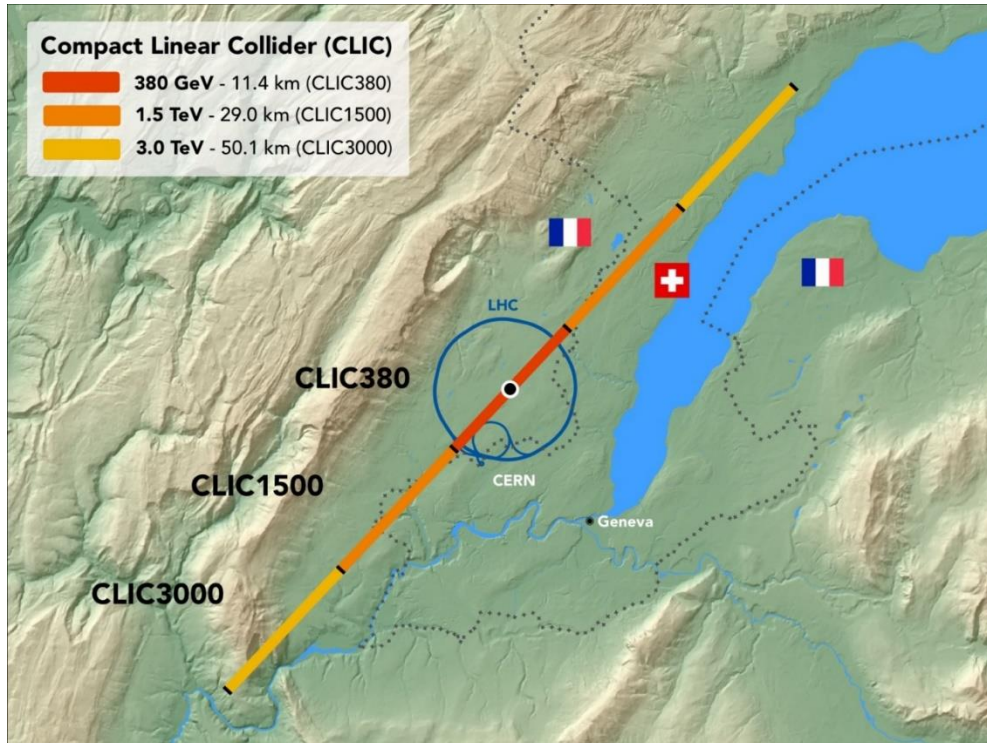

CLIC CDR <https://clic-study.web.cern.ch/content/conceptual-design-report> and update <https://clic-study.web.cern.ch/content/updated-baseline-document>



# CLIC technology transfer

An important priority for the CLIC study has been to help promote the use of X-band and high-gradient technology in diverse applications.

The objectives are to:

- expand the high-gradient community,
- broaden the technical base,
- add to resources beyond those currently available
- and provide a near-term return on the investment in the technology development we have made.

See for example



<https://indico.cern.ch/event/1071466/>

The screenshot shows a Zoom meeting agenda for 'CLIC Project Meeting #40' on Tuesday, Oct 5, 2021, from 1:30 PM to 6:15 PM. The agenda includes the following items:

- 1:30 PM - 1:40 PM: Welcome and brief news** (Speaker: Steinar Stapnes (CERN))
- 1:45 PM - 2:00 PM: Melbourne X-band status and plans** (Speaker: Suzie Sheehy (University of Oxford and University of Melbourne))
- 2:05 PM - 2:20 PM: Tsinghua X-band activities** (Speaker: Jiaru Shi)
- 2:25 PM - 2:40 PM: LNF X-band linac and ongoing work** (Speaker: Fabio Cardelli (INFN - National Institute for Nuclear Physics))
- 2:45 PM - 3:00 PM: VHEE with high gradient linacs** (Speaker: Angeles Faus-Golfe (JCLab IN2P3 CNRS-Universit  Paris-Saclay (FR)))
- 3:05 PM - 3:20 PM: DEFT at CHUV/CERN** (Speaker: Walter Wuensch (CERN))
- 3:25 PM - 3:40 PM: The AWAKE X-band electron linac** (Speaker: Steffen Doebert (CERN))
- 3:45 PM - 4:00 PM: Coffee**
- 4:00 PM - 4:15 PM: SmartLight in Eindhoven, status and plans** (Speaker: Otger Jan Luiten)
- 4:20 PM - 4:35 PM: CompactLight with ICS focus, future ideas** (Speaker: Gerardo D'Aurila (Elettra Trieste))
- 4:40 PM - 4:55 PM: ICS studies at CERN** (Speaker: Vlad MUSAT (University Politehnica of Bucharest (RO)))
- 5:00 PM - 5:15 PM: CLEAR and X-boxes at CERN** (Speaker: Roberto Corsini (CERN))
- 5:20 PM - 5:35 PM: X-band status at DESY** (Speakers: Daniel Jurgensen (DESY), Heliko Ehrlichmann (Deutsches Elektronen-Synchrotron DESY))
- 5:40 PM - 5:50 PM: AOB/CLOSE**

# X-band and high-gradient applications overview

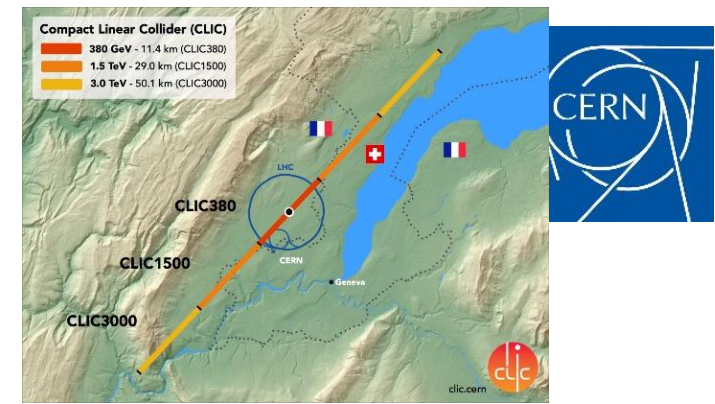
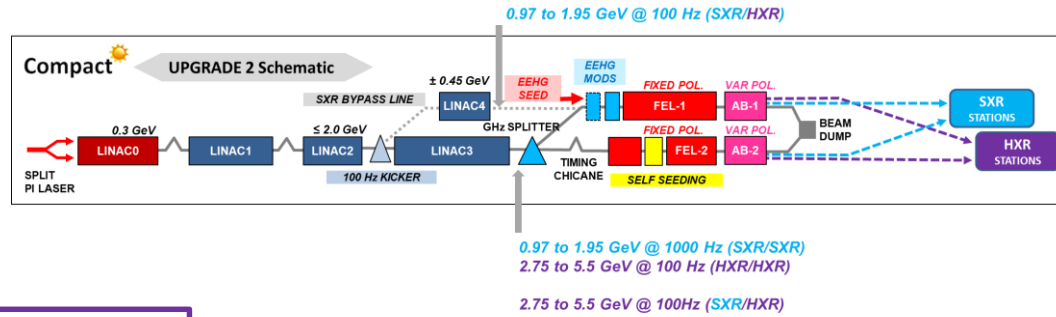
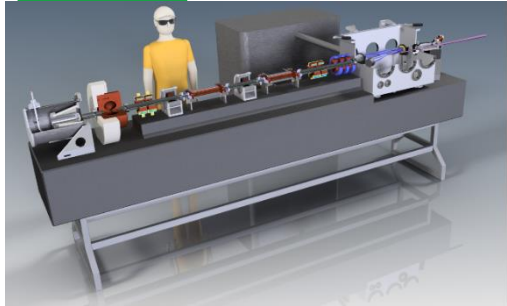

Linear collider

Light source - Inverse Compton Scattering Source

Light source - XFEL

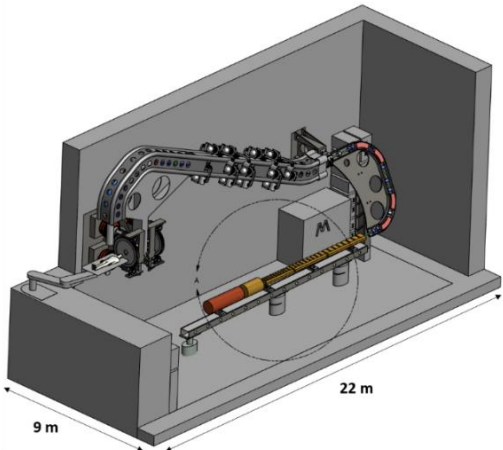
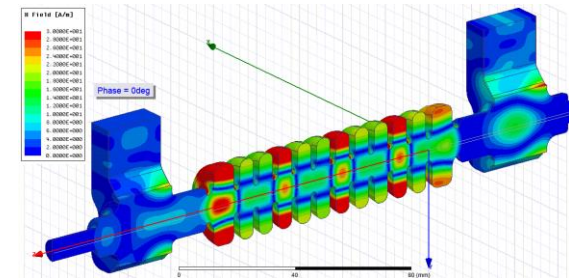

Medical applications

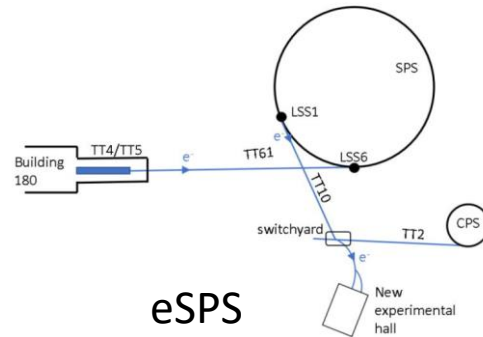

GeV-range research linacs

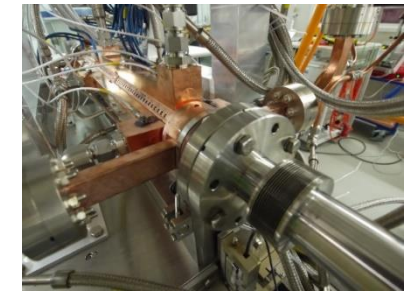
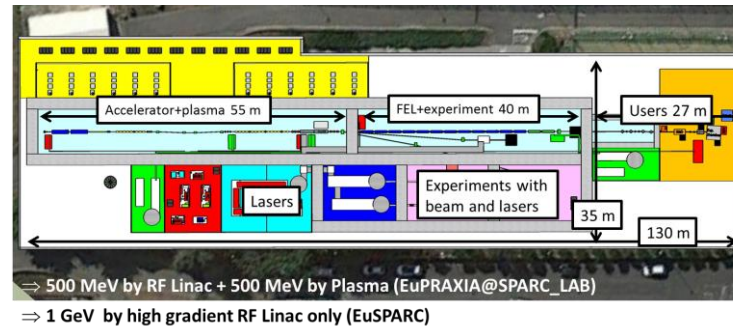

Beam manipulation



# Working environment



Let me be clear, I will be vague

...about many aspects of the project. I apologize, but the medical world is complicated to navigate.

Still I hope to give you a good idea about the basic principles of our facility and an insight into the technology that makes it happen.

# Layout

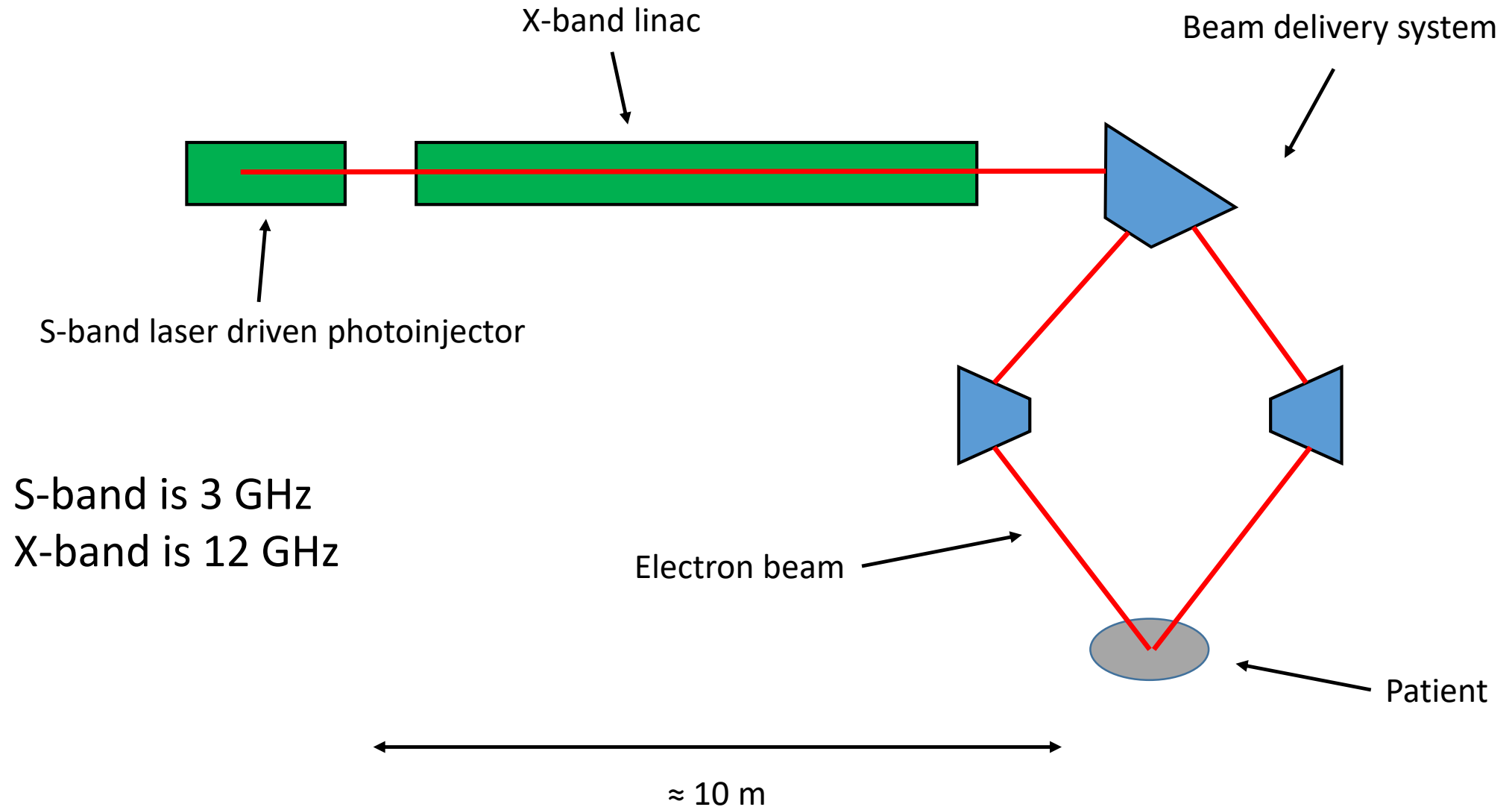

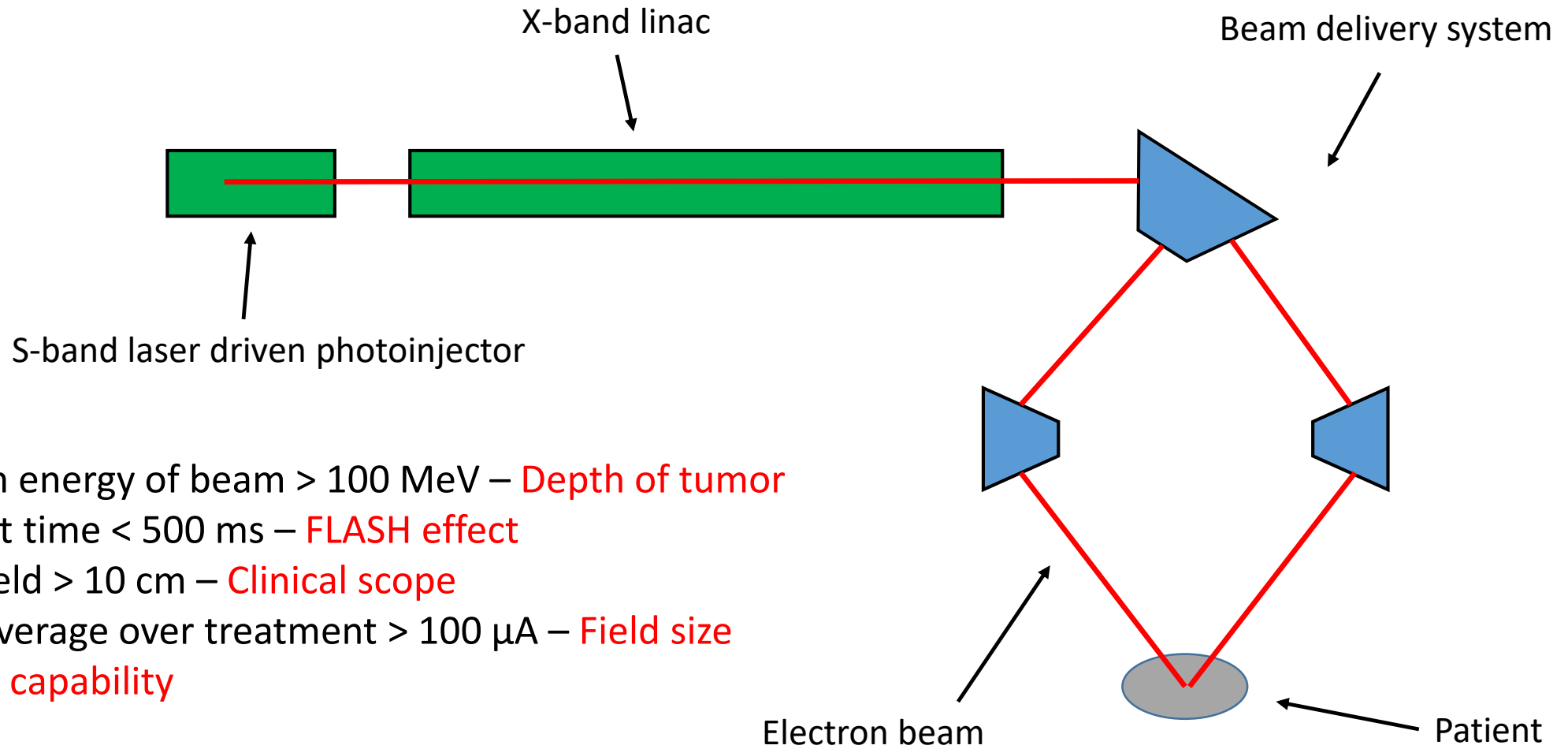

- Maximum energy of beam  $> 100$  MeV – **Depth of tumor**
- Treatment time  $< 500$  ms – **FLASH effect**
- Largest field  $> 10$  cm – **Clinical scope**
- Current average over treatment  $> 100$   $\mu$ A – **Field size over time capability**

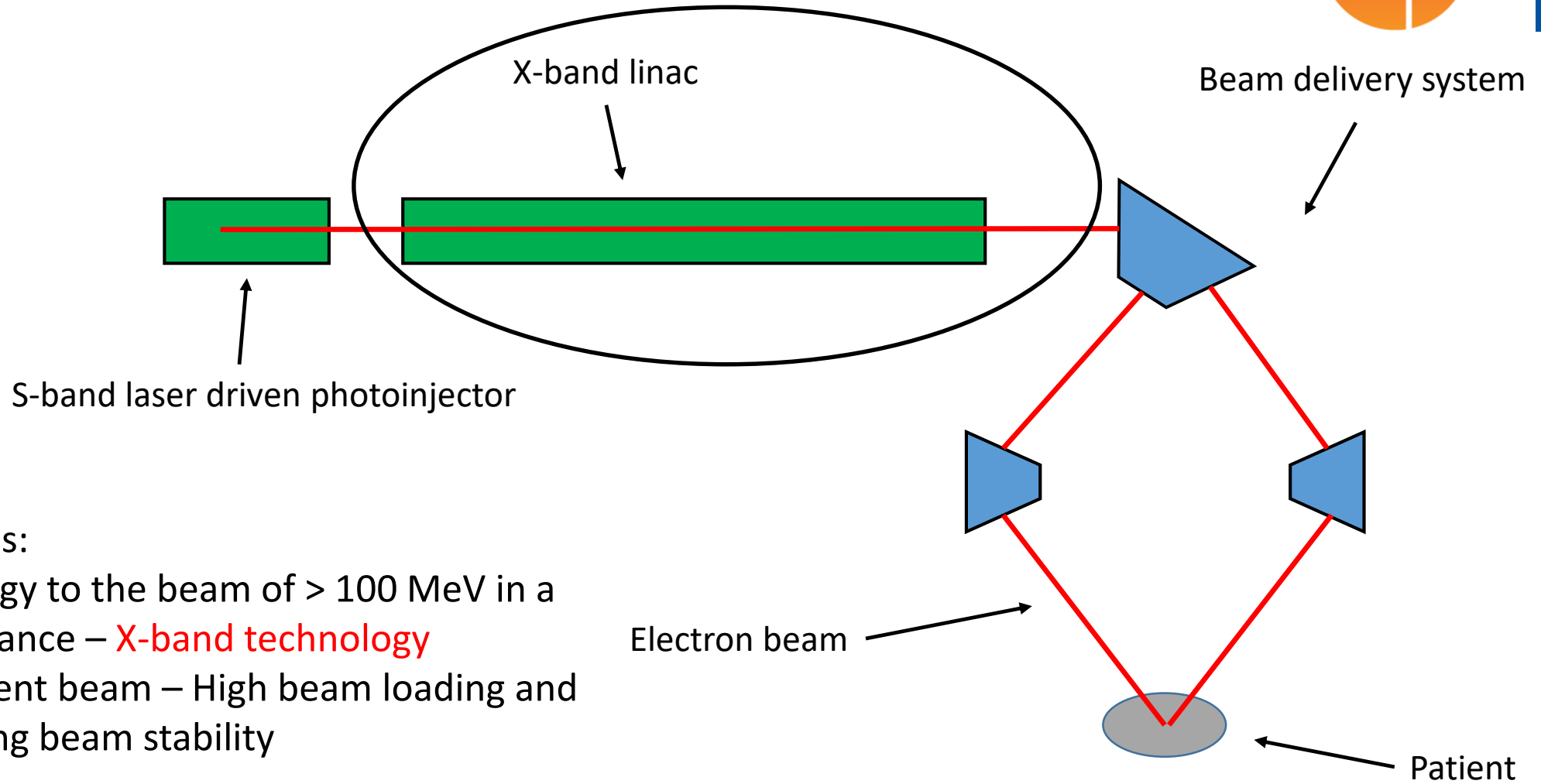

Critical issues:

- Give energy to the beam of  $> 100$  MeV in a short distance – **X-band technology**
- High current beam – High beam loading and challenging beam stability



# X-band linac hardware



Based on CLIC accelerating structures and XBox test stands.

CPI 50 MW klystron

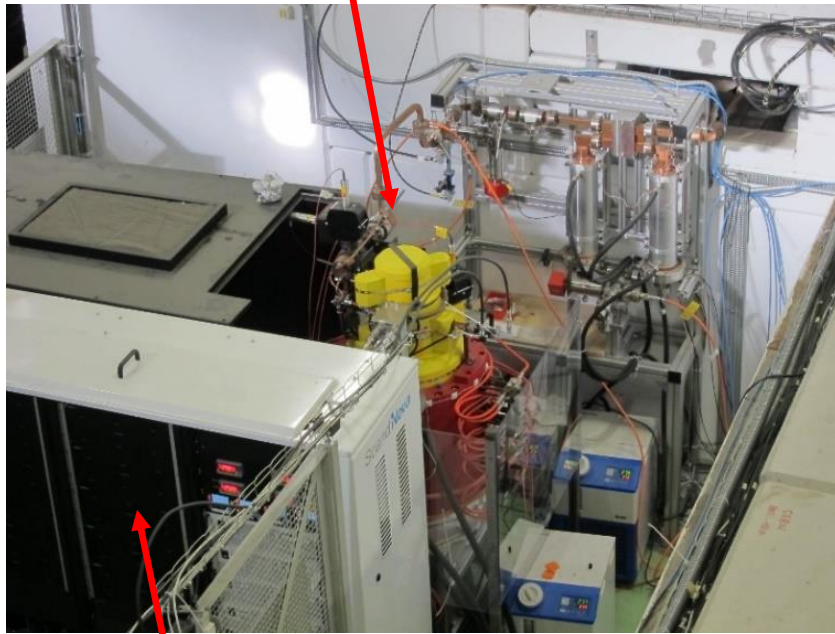
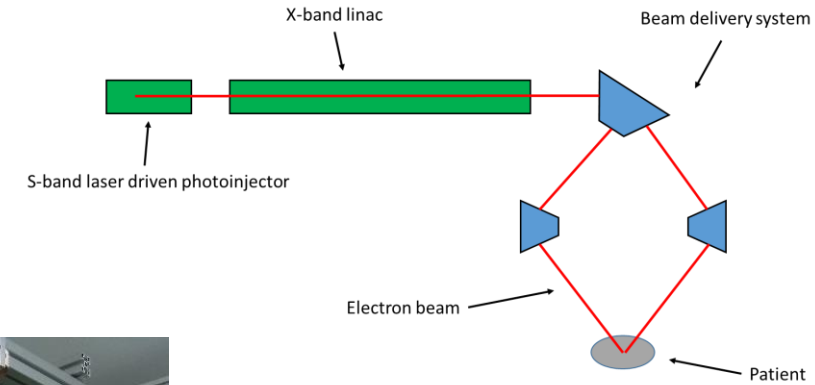

Scandinova solid state modulator

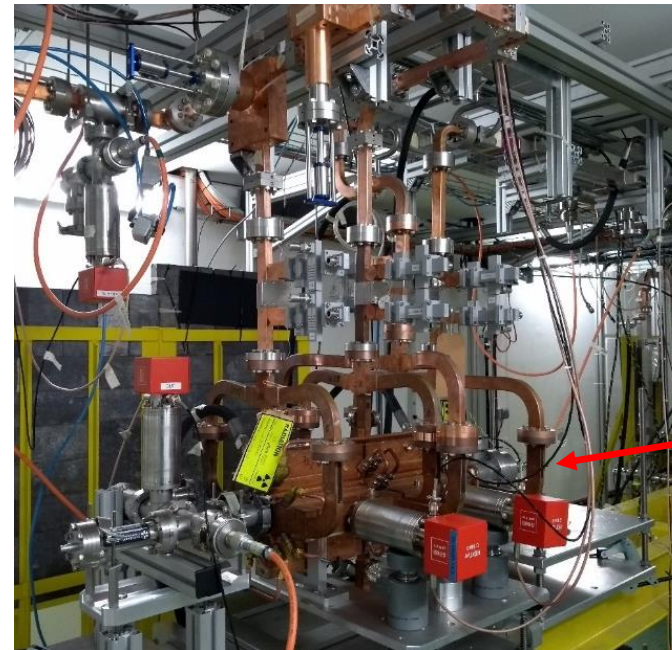

Prototype CLIC accelerating structure

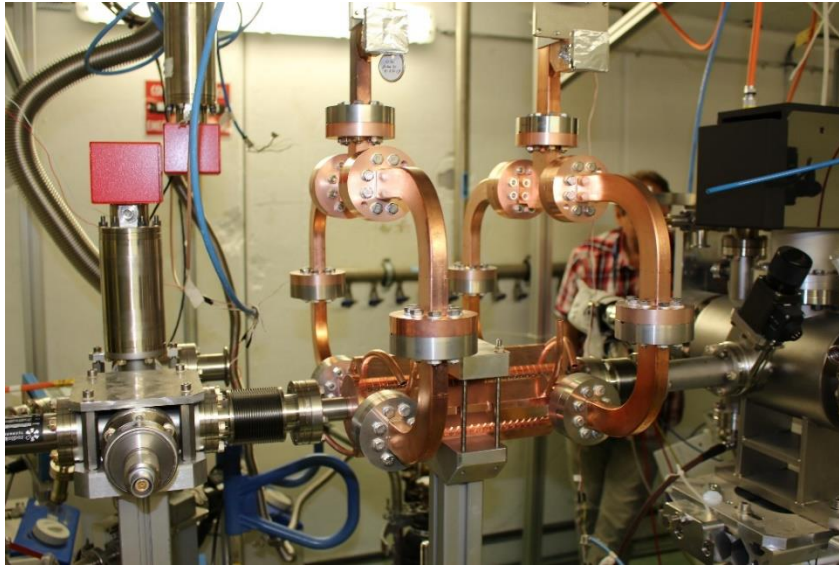

Test structure

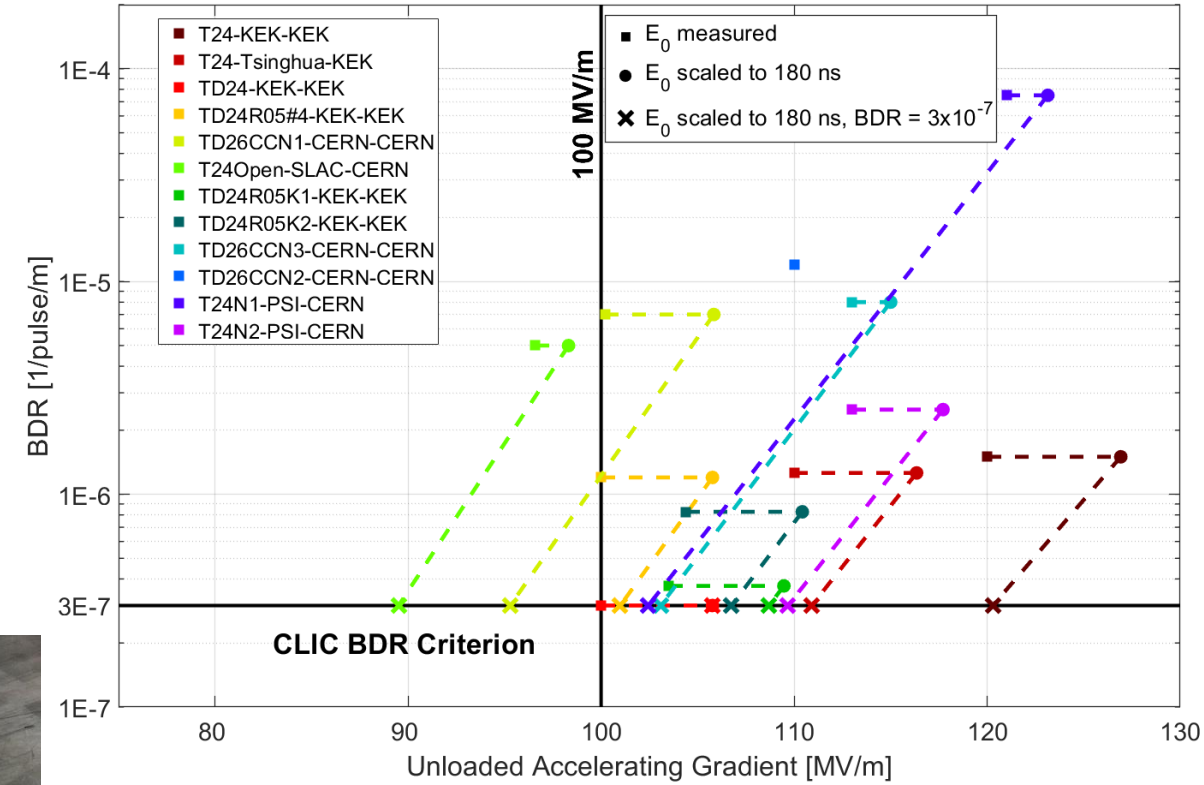

Achieved accelerating gradients in tests



Assembly methods

High-current beam requires Higher-Order-Mode suppression for beam stability, just like CLIC

## Transverse long-range Wakefield in CLIC-G structure

Structure name	CLIG-G TD26cc
Work frequency	11.994GHz
Cell	26 regular cells+ 2 couplers
Length (active)	230mm
Iris aperture	2.35mm - 3.15mm

transverse long-range wakefield calculation using Gdfidl code:

Peak value :  
**250 V/pC/mm**  
 At position of second bunch (0.15m):  
**5~6 V/pC/mm**  
 Beam dynamic requirement:  
**< 6.6 V/pC/mm**

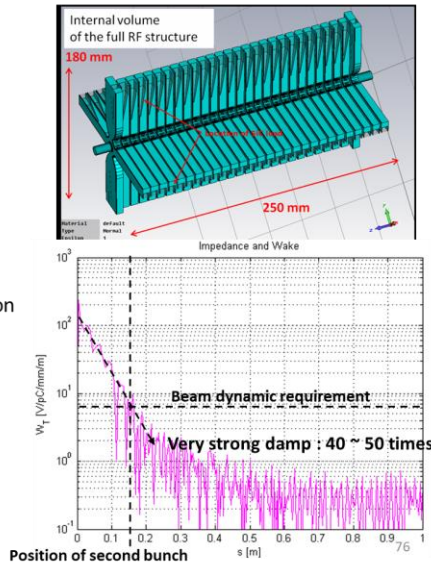

## Direct wakefield measurement in FACET

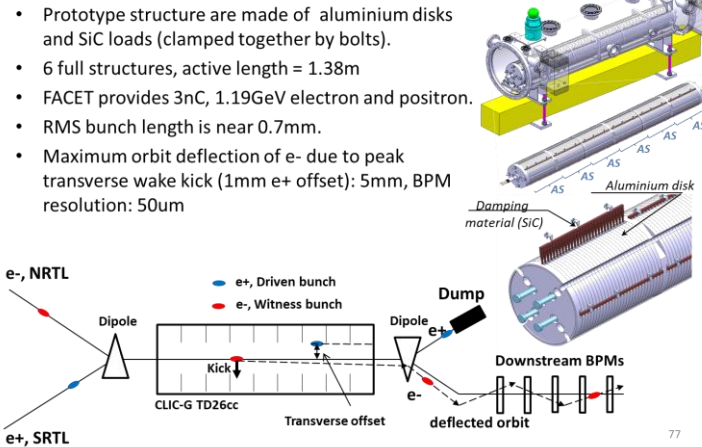

## Timing correction

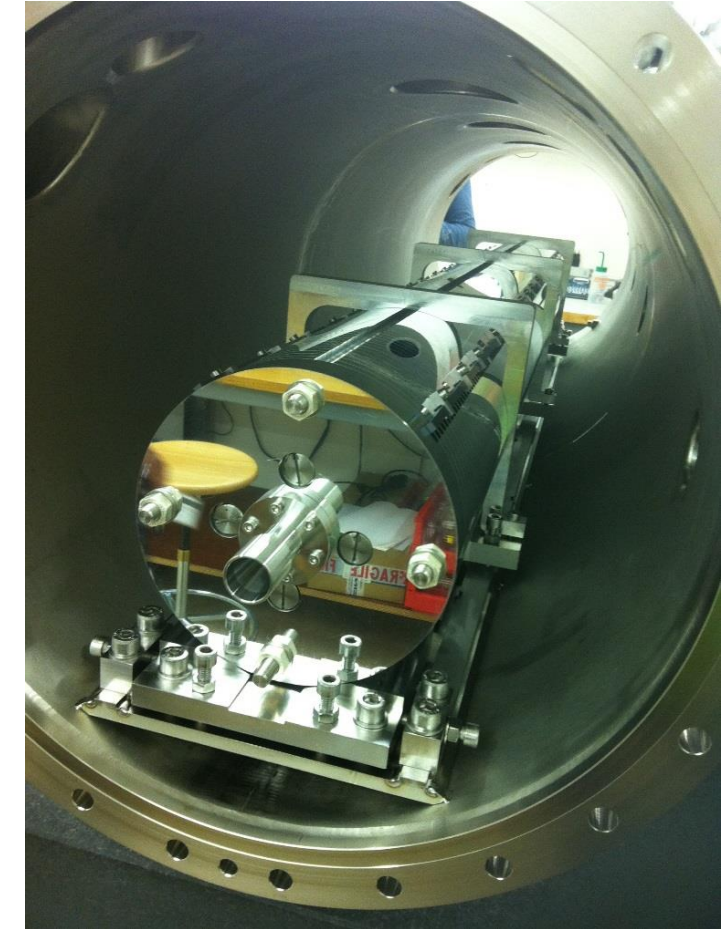
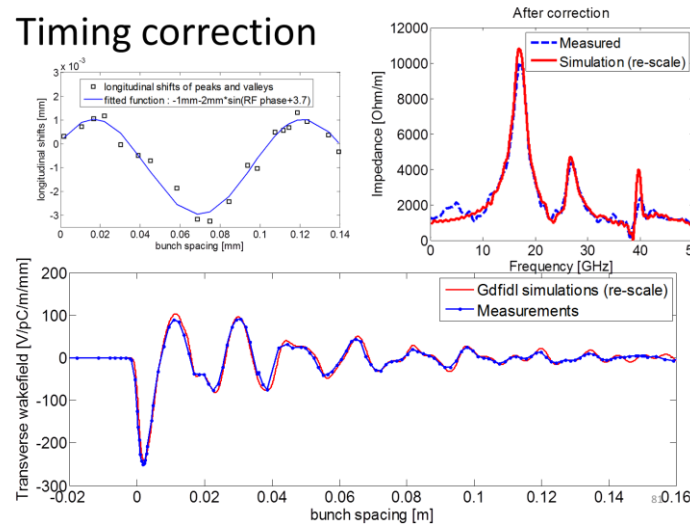

<https://doi.org/10.1103/PhysRevAccelBeams.19.011001>

# CLIC klystron-based rf module

BOC cavities  
x 3.5 pulse compression

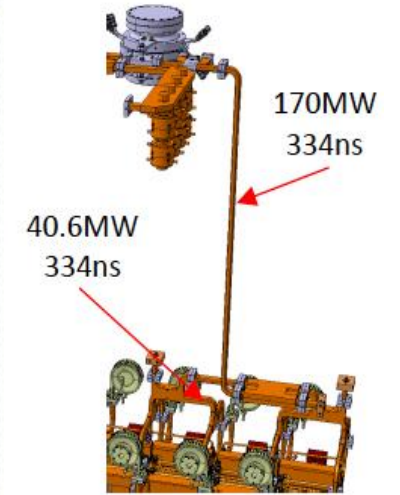
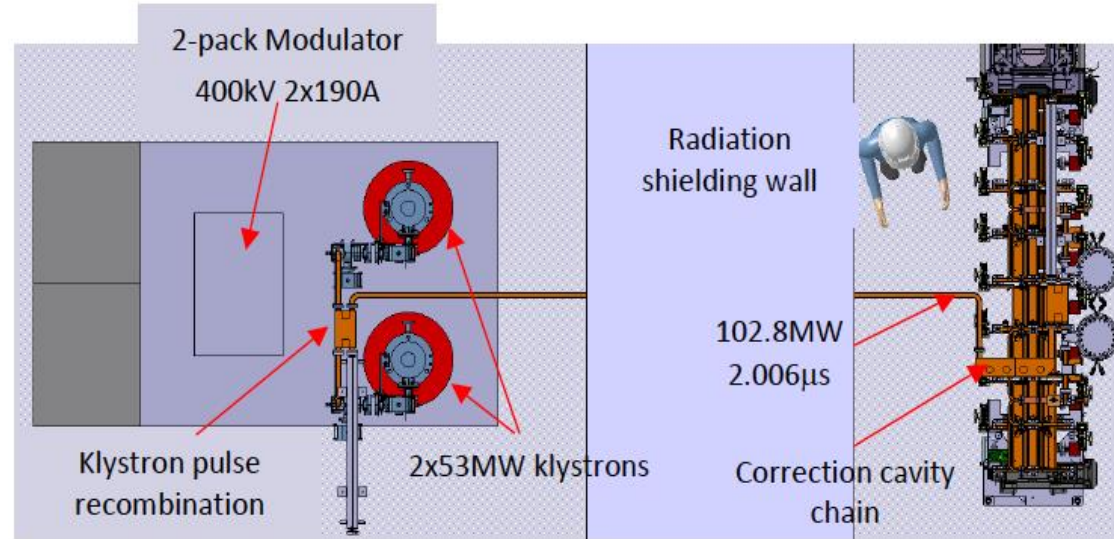
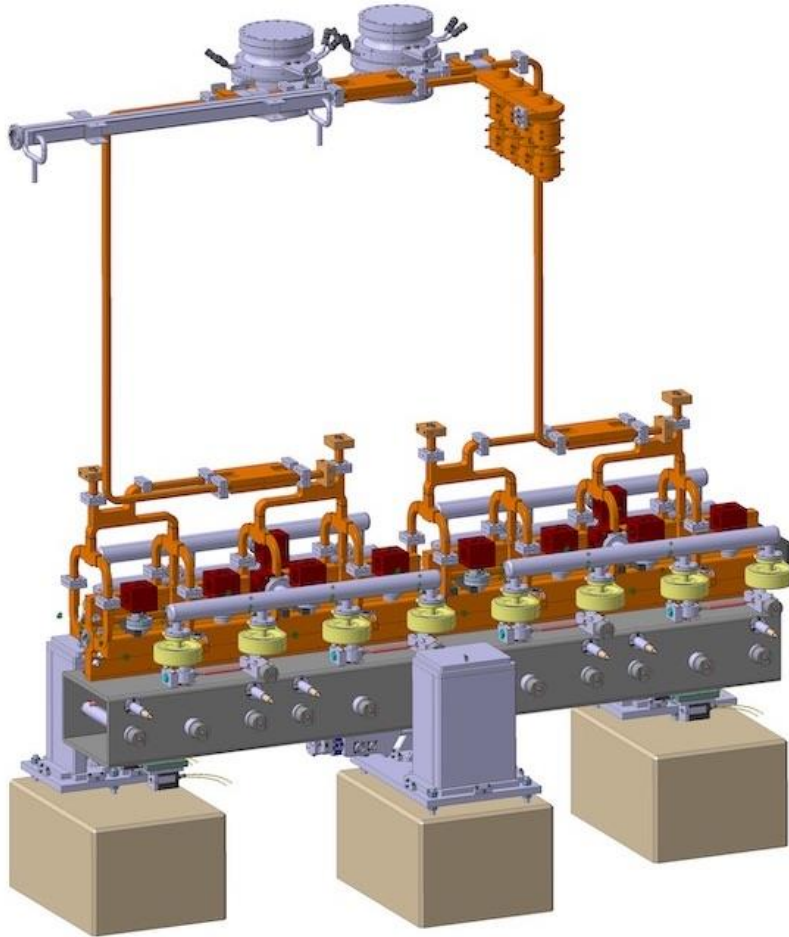

CLIC has as a baseline two-beam RF power generation, but we have also studied a klystron-based version.

- 160 MeV energy gain
- 2 m long
- 1 A beam current
- (round numbers)



Existing commercial CPI 50 MW klystron in Xbox-2

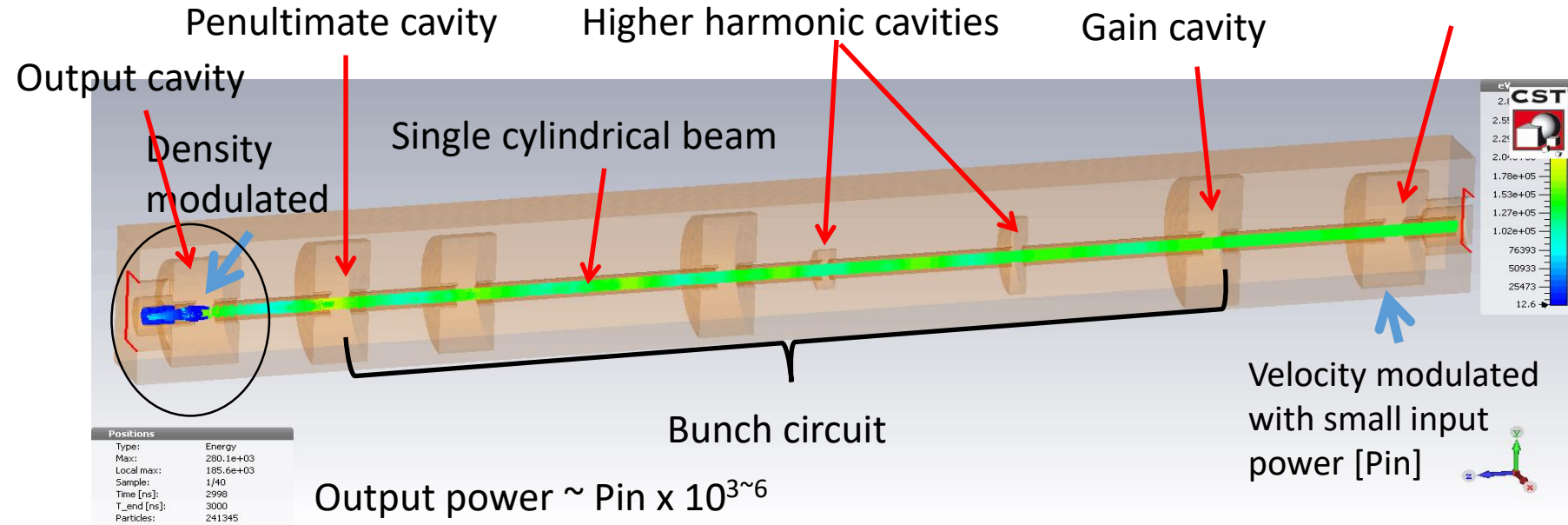

New high-efficiency design fully simulated 36 to 68 % electronic efficiency. Improves performance and lowers cost for DEFT.

J. Cai

# The S-band photoinjector

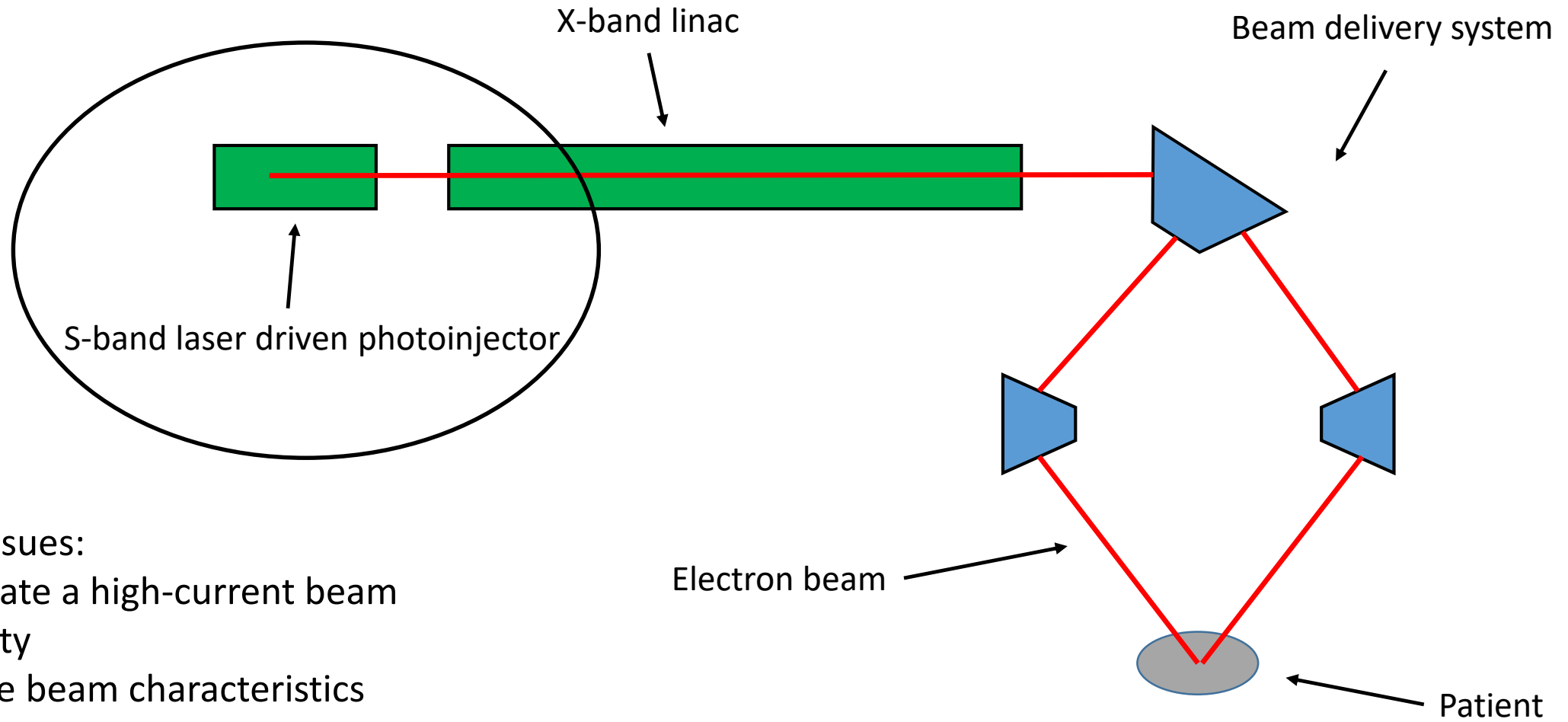

Critical issues:

- Generate a high-current beam
- Stability
- Precise beam characteristics

Laser-driven RF photoinjectors are a commonly used device to provide well controlled electron bunches in a wide variety of linacs including XFELs, Inverse Compton Sources, ERLs, linear collider related test facilities etc.

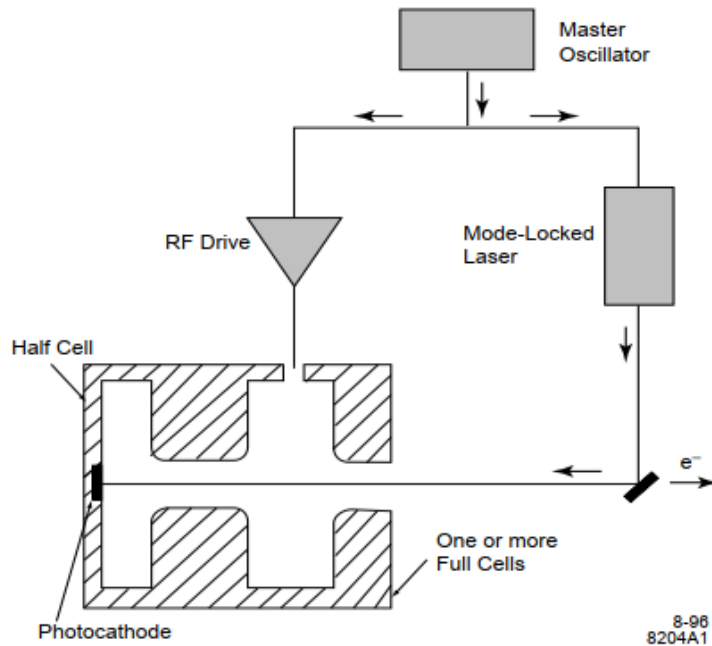
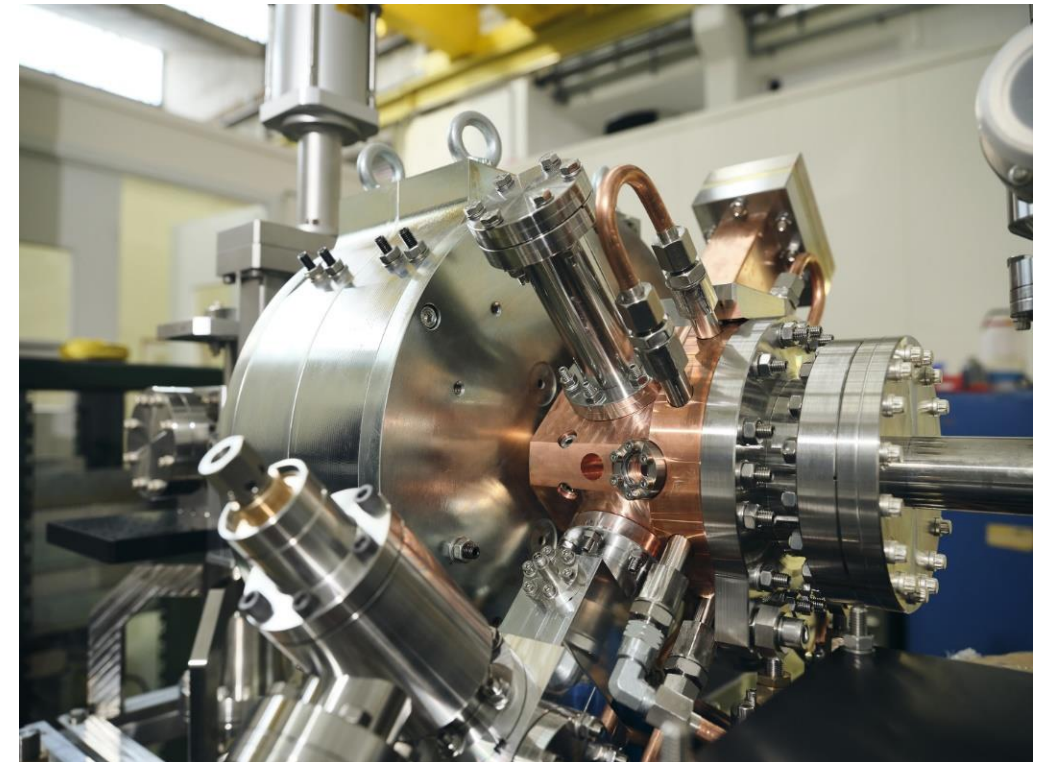

Fig. 1. Principal components of an rf photoinjector.

From J.E. Clendenin, LINAC96



2021 - New CLEAR gun from INFN Frascati

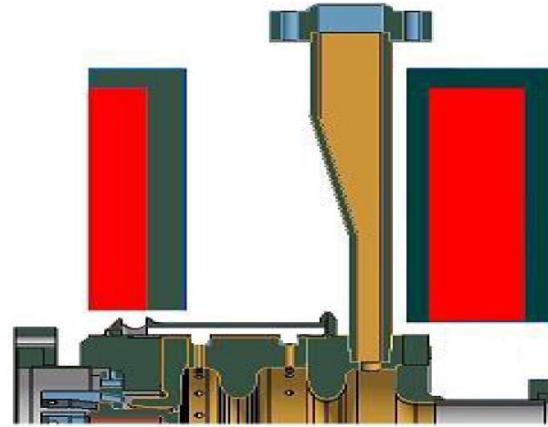
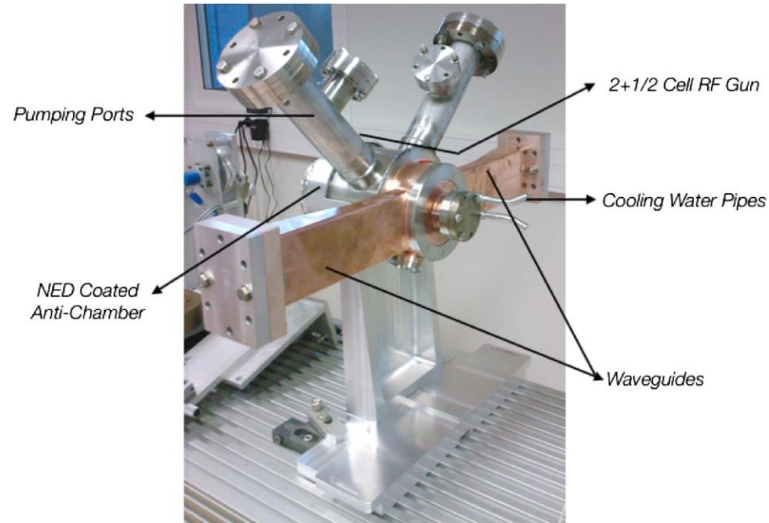

Figure 2: cut in the horizontal plane of the technical drawing of the photo-injector. Red blocks are coils.

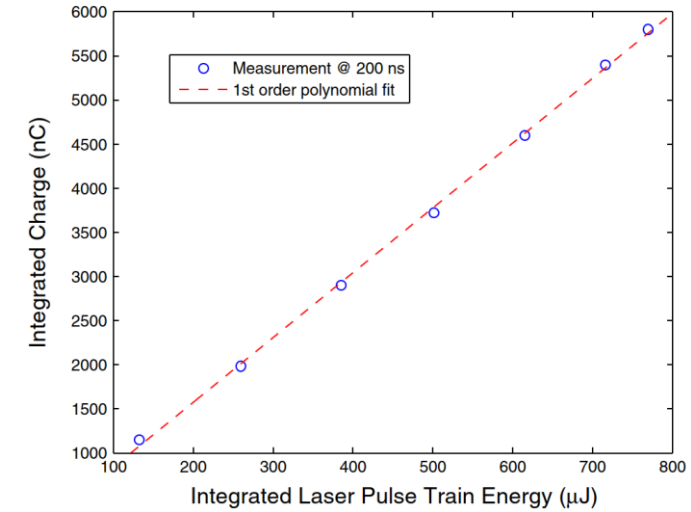
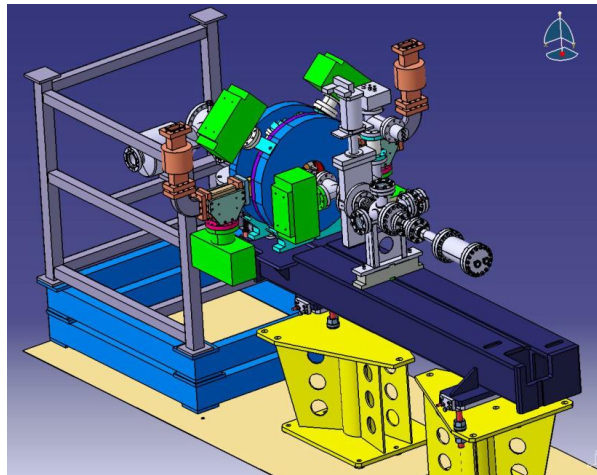

TABLE IV. The specifications for the PHIN photoinjector in comparison with the achieved values during the short intermittent runs between 2008–2011.

Parameter	Specification	Achieved
<i>Laser</i>		
UV laser pulse energy (nJ)	370	400
Micropulse repetition rate (GHz)	1.5	1.5
Macropulse repetition rate (Hz)	1–5	1
Train length (ns)	1273	1300
<i>Electron beam</i>		
Charge per bunch (nC)	2.33	8.1@50 ns 4.4@200 ns
Charge per train (nC)	4446	5800
Bunch length (ps)	8	6.5
Current (A)	3.5	6.6
Transverse normalized emittance (mm mrad)	<25	14
Energy spread (%)	<1	0.7
Energy (MeV)	5.5	5.5
Charge stability (% rms)	<0.25	0.8
<i>rf gun</i>		
rf gradient (MV/m)	85	85
Quantum efficiency (%)	3	3–18



<https://doi.org/10.1103/PhysRevSTAB.15.022803>

# The beam delivery system

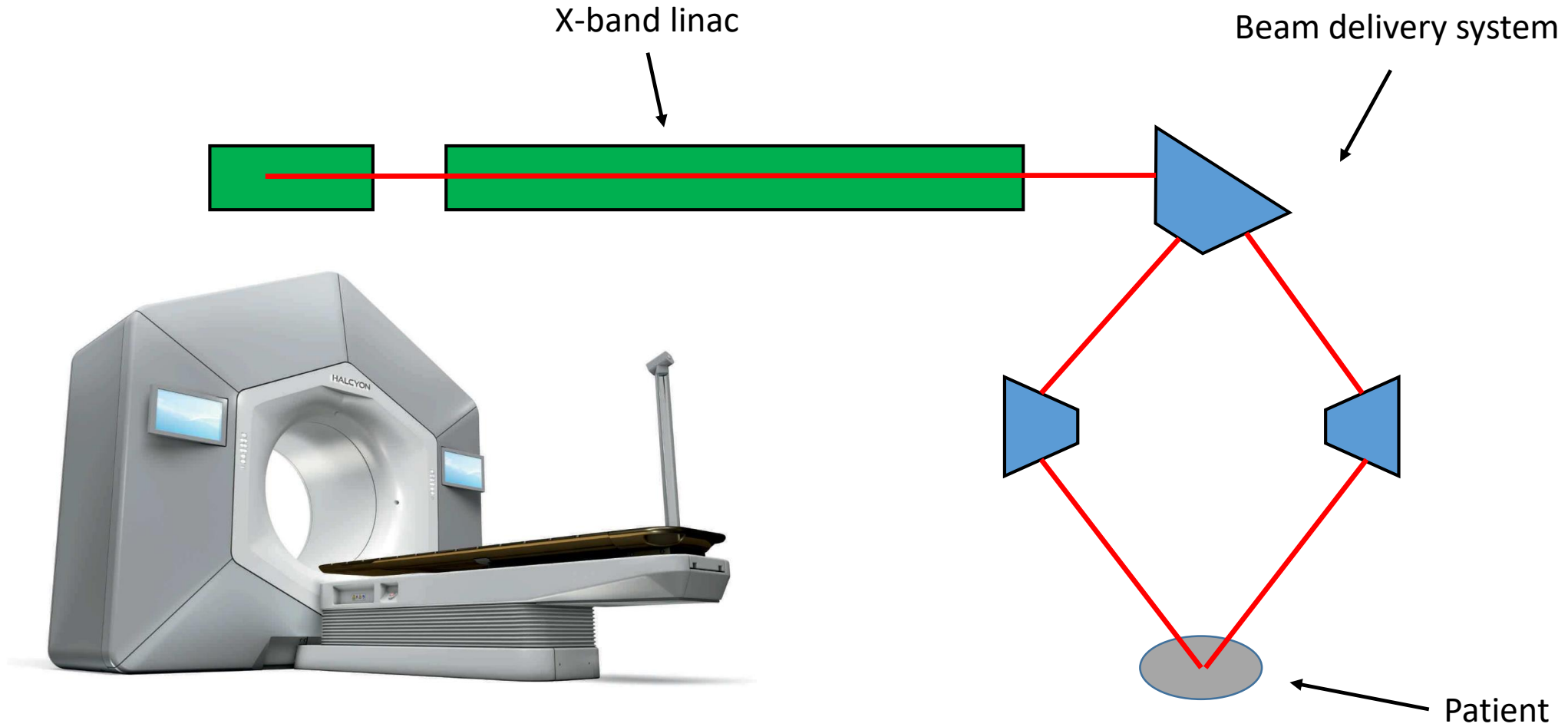

XRay therapy system  
from <https://www.varian.com/en-ch>

(not same scale)

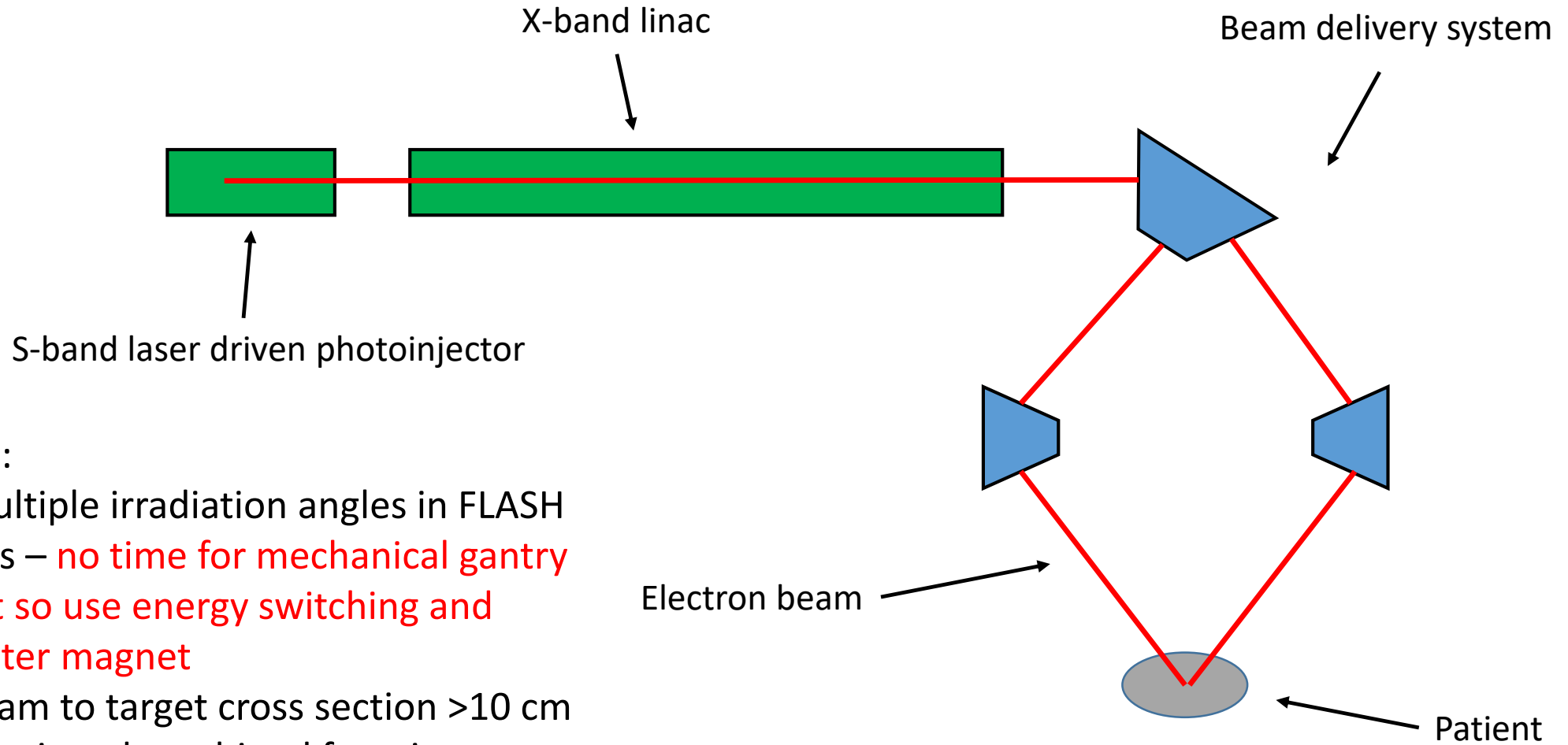

Critical issues:

- Provide multiple irradiation angles in FLASH sub-100 ms – **no time for mechanical gantry movement so use energy switching and spectrometer magnet**
- Expand beam to target cross section >10 cm
- Specially designed combined function separator magnet.

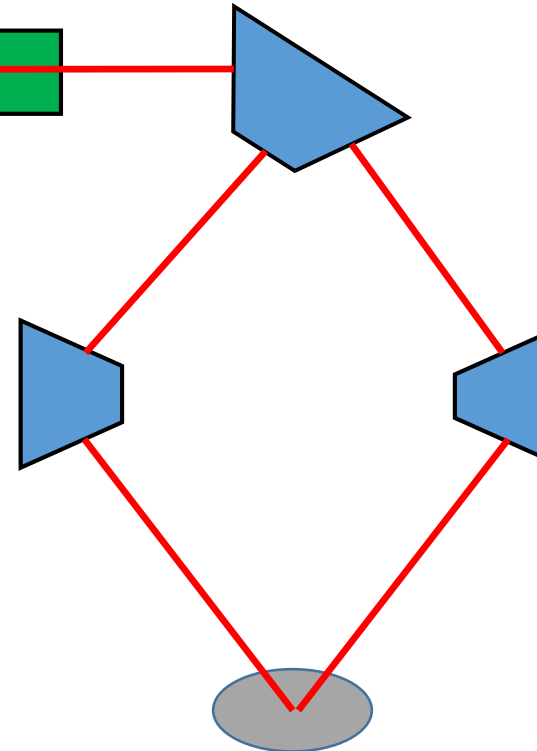
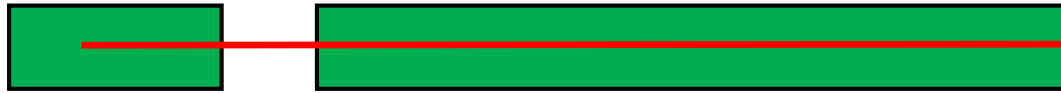

LINAC2

XBox-3 high-gradient test stand. Klystrons operate at 400 Hz, alternatively powering two test slots at 200 Hz.

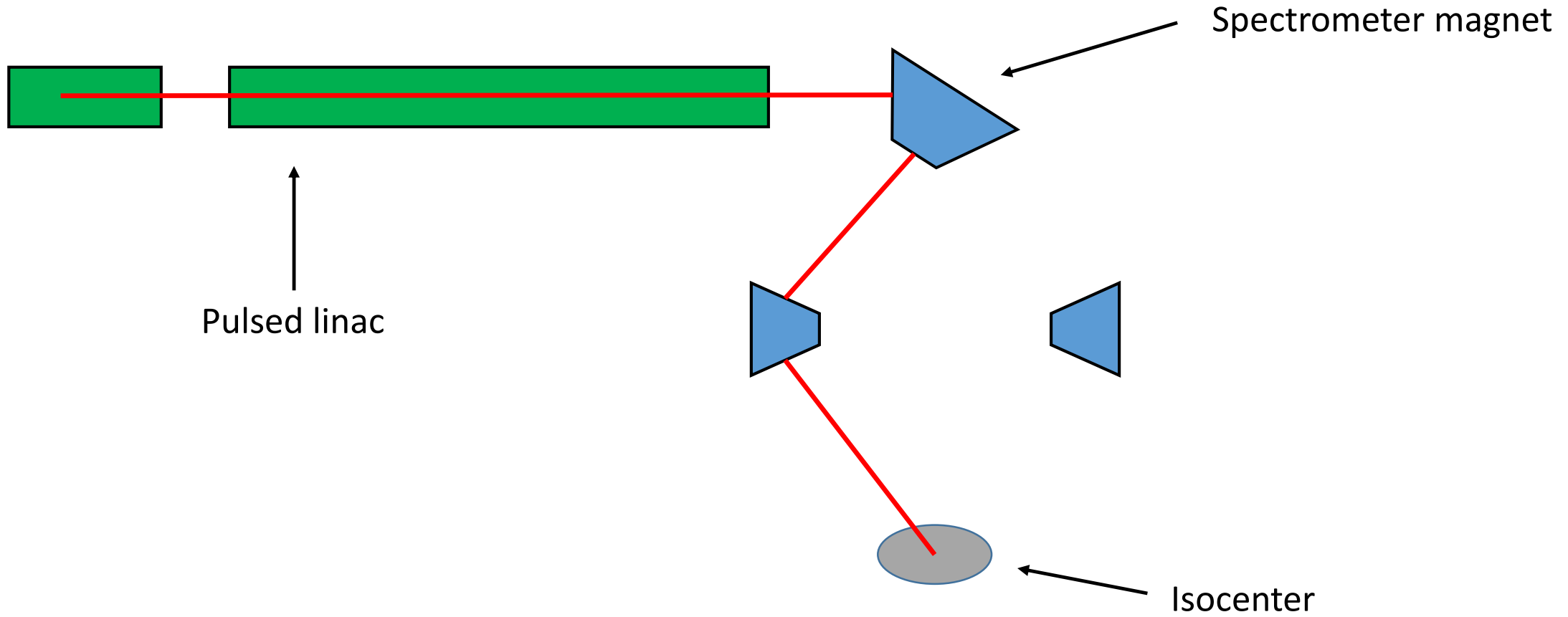

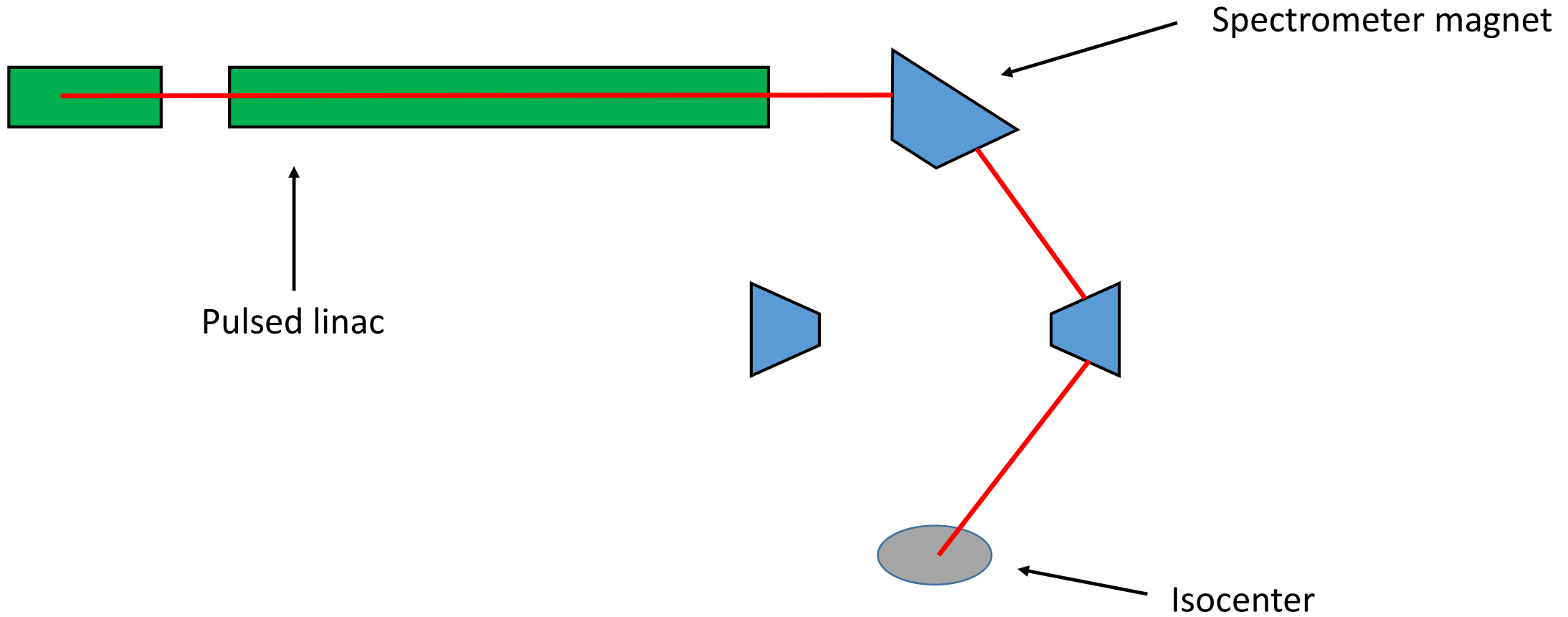

# The overview again

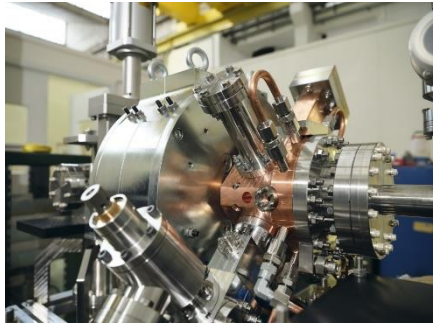

S-band laser driven photoinjector

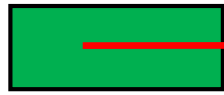

X-band linac

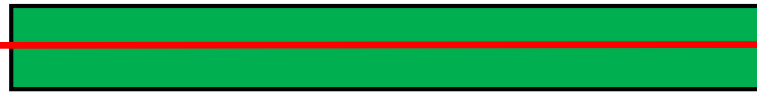

Beam delivery system



Electron beam

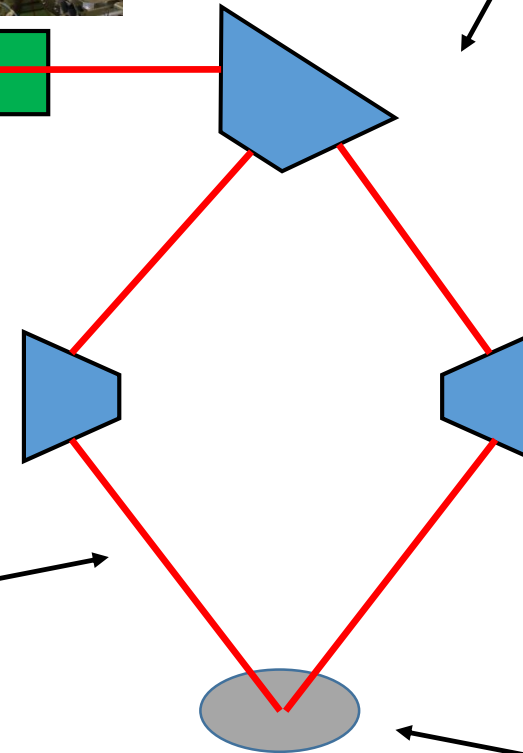

Patient



≈ 10 m

CLEAR – 200 MeV electron linac user facility serving many communities. Beam diagnostics, THz, plasma acceleration, irradiation and VHEE (Very High Energy Electron) medical.



## High dose rate dosimetry

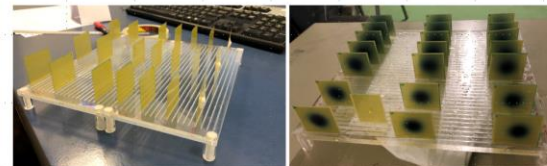

Films set-up for profile depth dose, CHUV Lausanne (M.C. Vozenin, C. Bailat, R. Moeckli et al.)

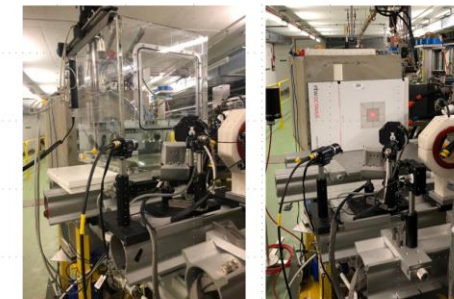

Advance Markus chambers and SRS Array, Oldenburg University and PTW (B. Poppe, D. Poppinga et al.)

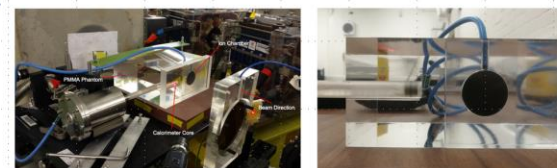

Calorimeter and ROOS chamber, Nat. Phys. Lab. UK (A. Subiel et al.)

Workshop on accelerator technology for particle therapy, 7-8 December 2020



## VHEE at CERN



R. Corsini

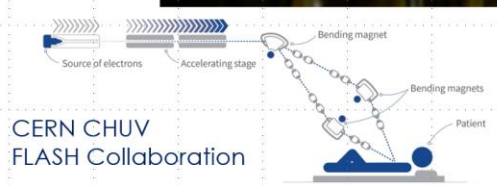
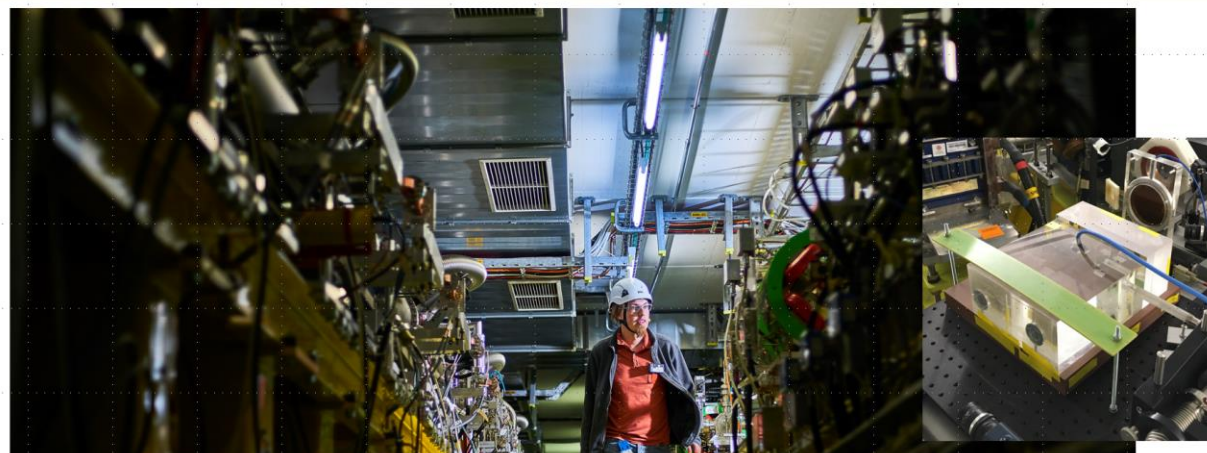

CERN Linear Electron Accelerator for Research

## Example of FLASH studies in CLEAR

We are benefiting from a remarkable confluence of a major development in radiation therapy with the fruition of a significant advance in accelerator technology.

The project represents an excellent example of knowledge transfer between fields.

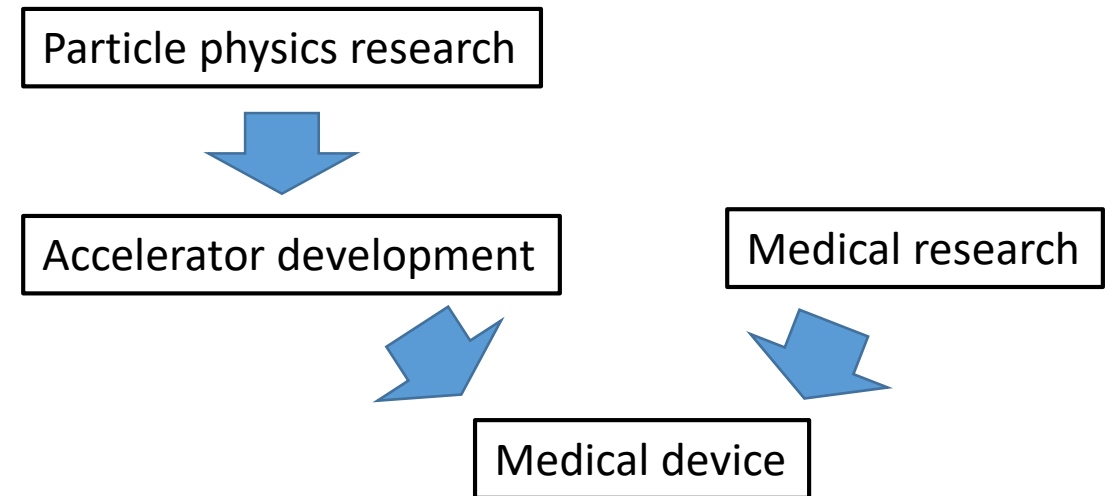

**Thank you for your attention!**

# Acknowledgements

To the CERN-CDR team:

Alexander Gerbershagen

Alexej Grudiev

Andrea Latina

Benjamin Frisch

Carlo Rossi

Jeremie Bauche

Liam Dougherty

Luke Dyks

Manjit Dosanjh

Markus Widorski

Mick Draper

Roberto Corsini

Steinar Stapnes

Vera Korchevnyuk

to those that are now coming on board now for the ramp-up of the project,

to all my CLIC colleagues for all the Lego blocks,

and to the colleagues at CHUV.