

New Avenues for Light Dark Matter Direct Detection



Yonit Hochberg



האוניברסיטה העברית בירושלים
THE HEBREW UNIVERSITY OF JERUSALEM



The Universe is Dark

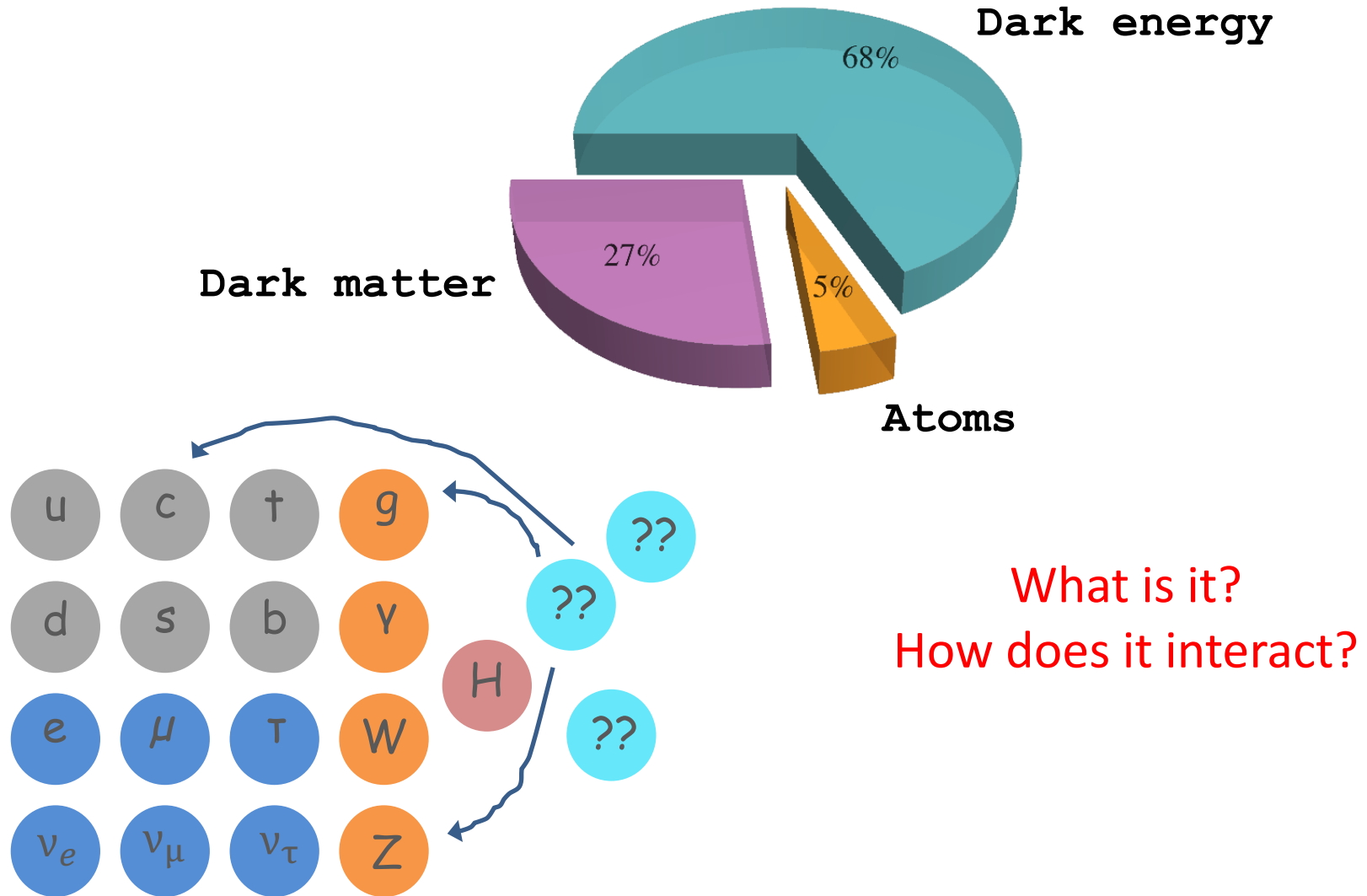

Past 40 years

WIMP, glorious WIMP*

{ *Also axions, of course
also axions :-) }

Past 40 years

Correct thermal relic abundance:

$$m_{\text{DM}} \sim \alpha \times 30 \text{ TeV}$$

For weak coupling, weak scale emerges.

Weakly Interacting Massive Particle (WIMP)

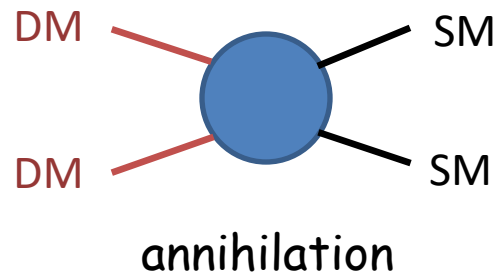

$$\langle \sigma_{\text{ann}} v \rangle = \frac{\alpha^2}{m_{\text{DM}}^2}$$

Searching for WIMPs

Direct production

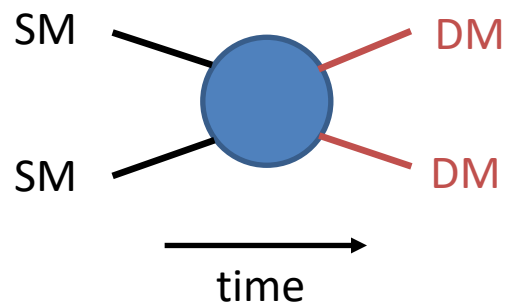

Direct detection

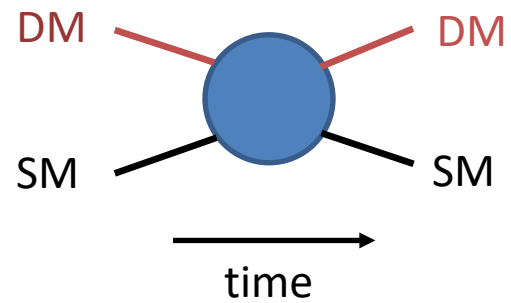
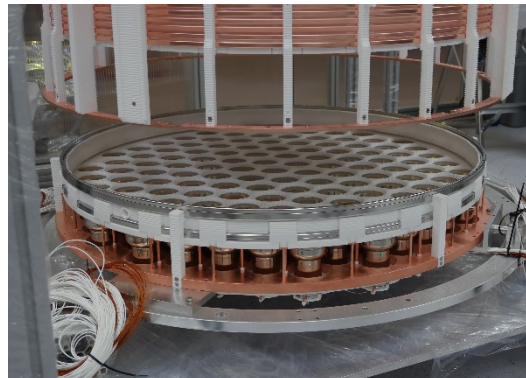

Indirect detection

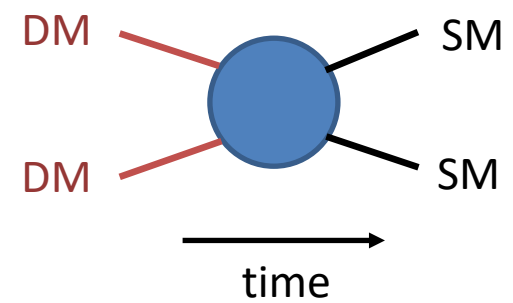
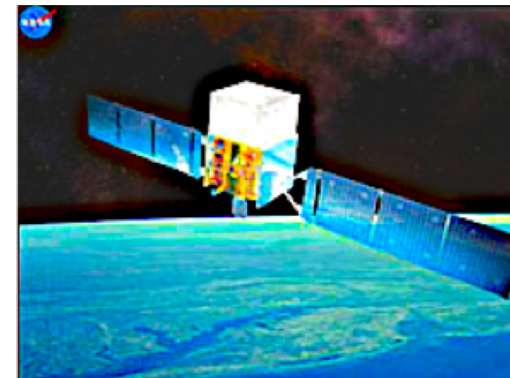

Searching for WIMPs

Direct production



Direct detection

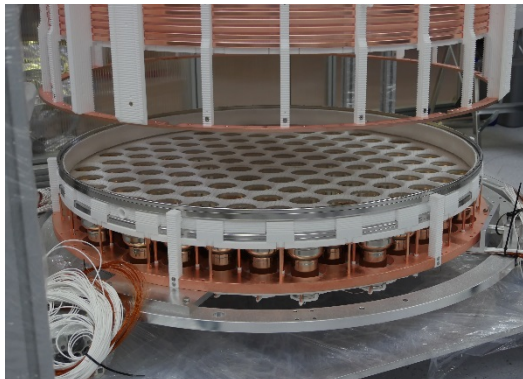

Indirect detection

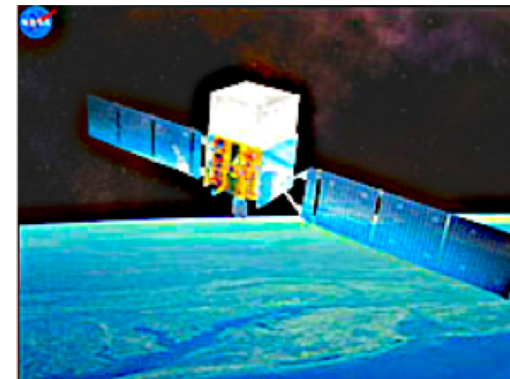

Experiments getting increasingly sensitive

Haven't yet detected dark matter



Great opportunity for new ideas.

Beyond the WIMP

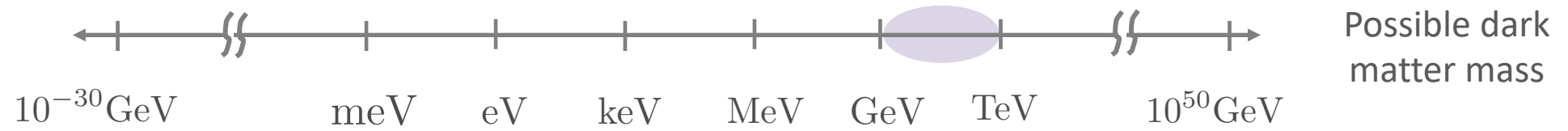

Beyond the WIMP

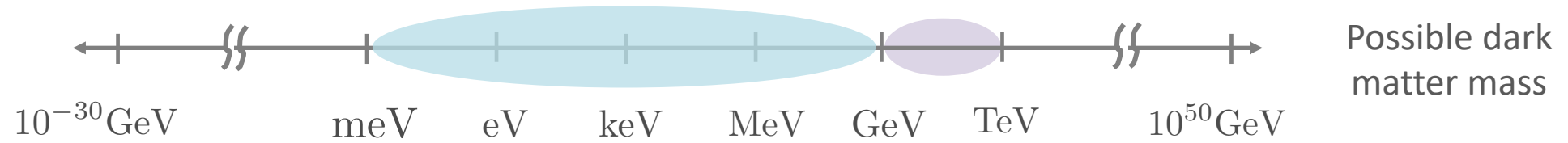

**New Frontier: Light Dark Matter
Theory + Experiment**



New Theory Ideas

-
- Weakly coupled WIMPs Pospelov, Ritz, Voloshin 2007; Feng, Kumar 2008
- Asymmetric dark matter Kaplan, Luty, Zurek, 2009
- Freeze-in dark matter Hall, Jedamzik, March-Russell, West, 2009
- SIMPs YH, Kuflik, Volansky, Wacker, 2014 | YH, Kuflik, Murayama, Volansky, Wacker, 2015
- ELDERs Kuflik, Perelstein, Rey-Le Lorier, Tsai, 2016 & 2017
- Forbidden dark matter Griest, Seckall, 1991 | D'Agnolo, Ruderman, 2015
- Co-decaying dark matter Dror, Kuflik, Ng, 2016
- Co-scattering dark matter D'Agnolo, Pappadopulo, Ruderman, 2017
-

... Are abundant

By no means a comprehensive list

Detection Blueprints

Dark matter particle comes in
Hits a target in the lab
System reacts
Measure the reaction

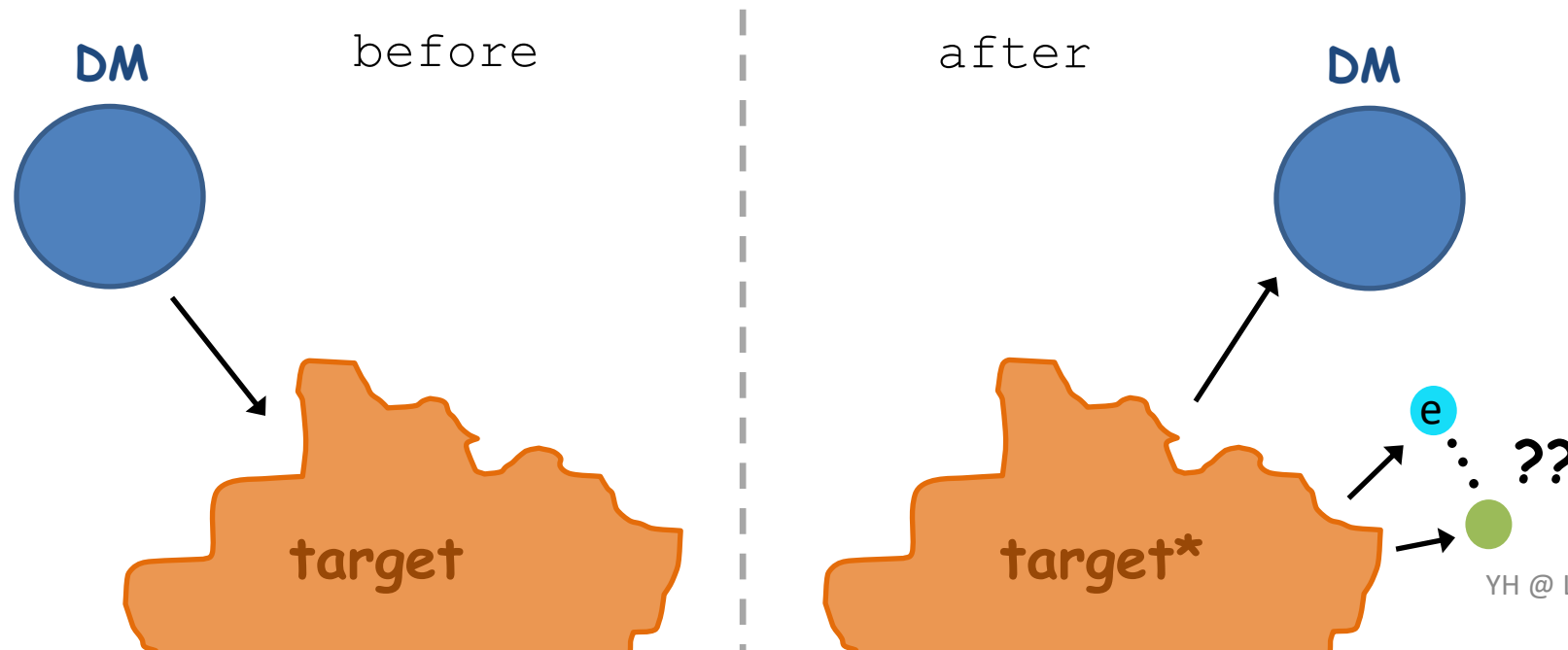

Direct Detection

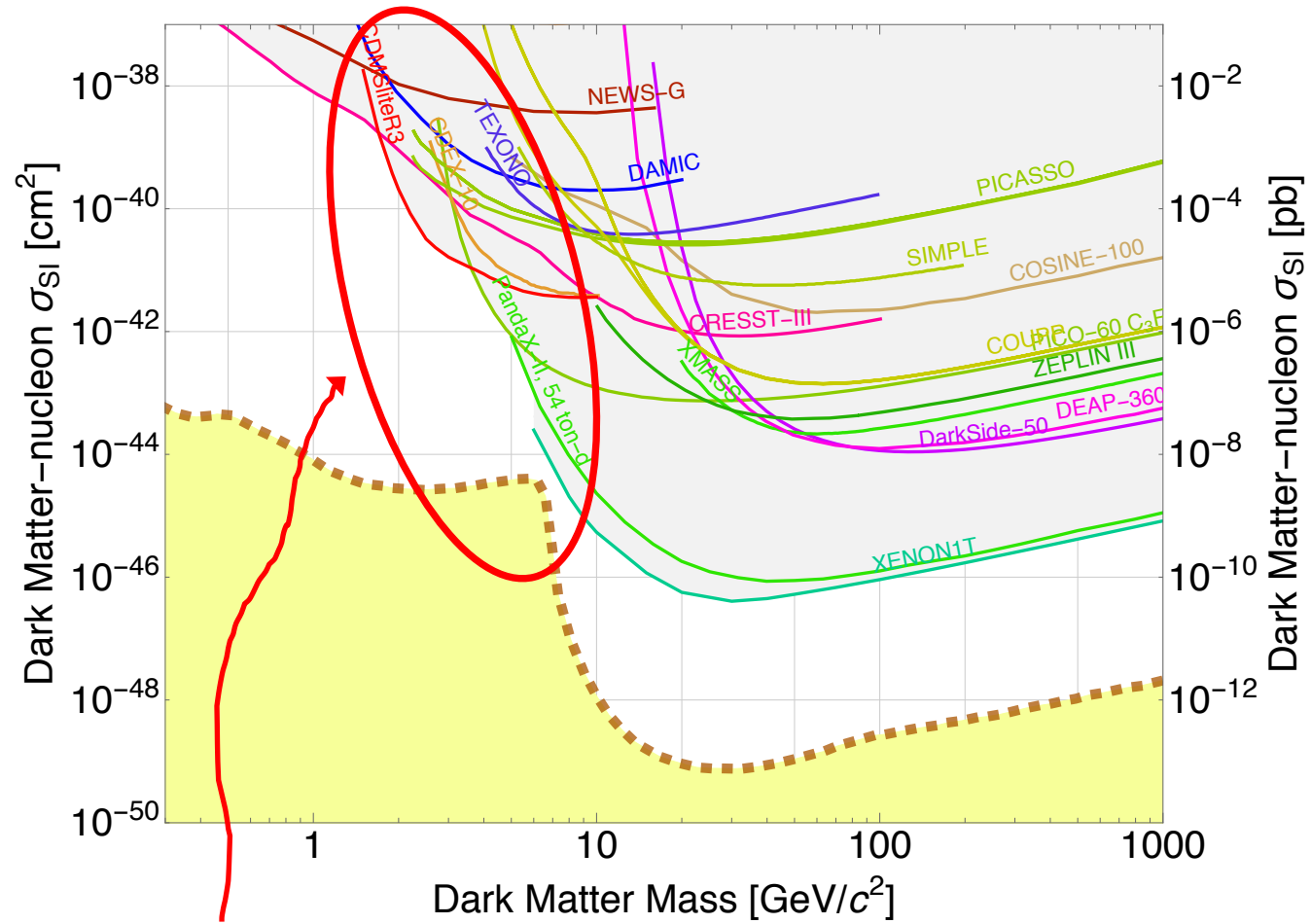

What's going on?

[website: supercdms.slac.stanford.edu/dark-matter-limit-plotter]

Current Experiments

Looking for nuclear recoils:
think billiard balls

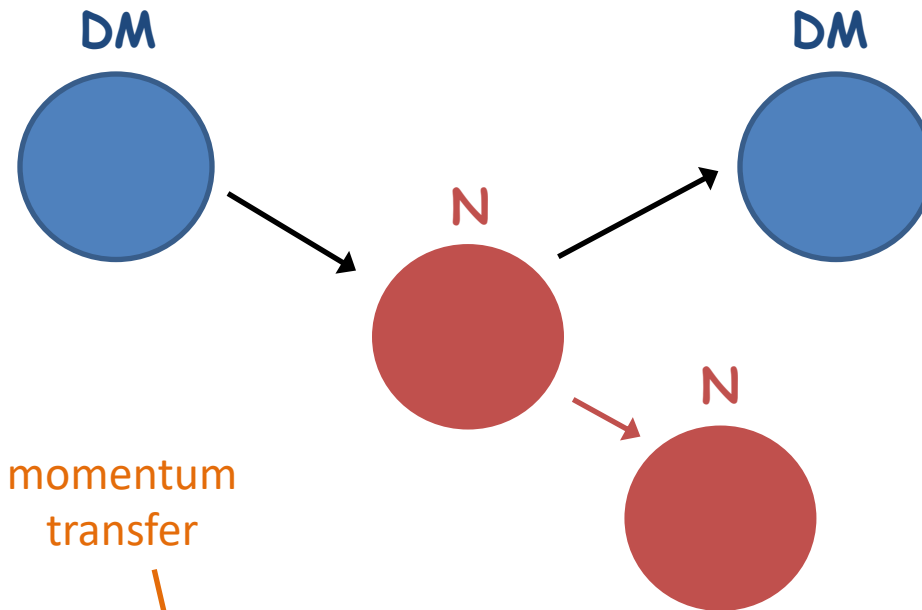

$$E_{\text{NR}} = \frac{q^2}{2m_N} = \frac{(m_{\text{DM}}v)^2}{2m_N} \gtrsim E_{\text{threshold}} \sim \text{keV}$$

Current Experiments

Looking for nuclear recoils:
think billiard balls

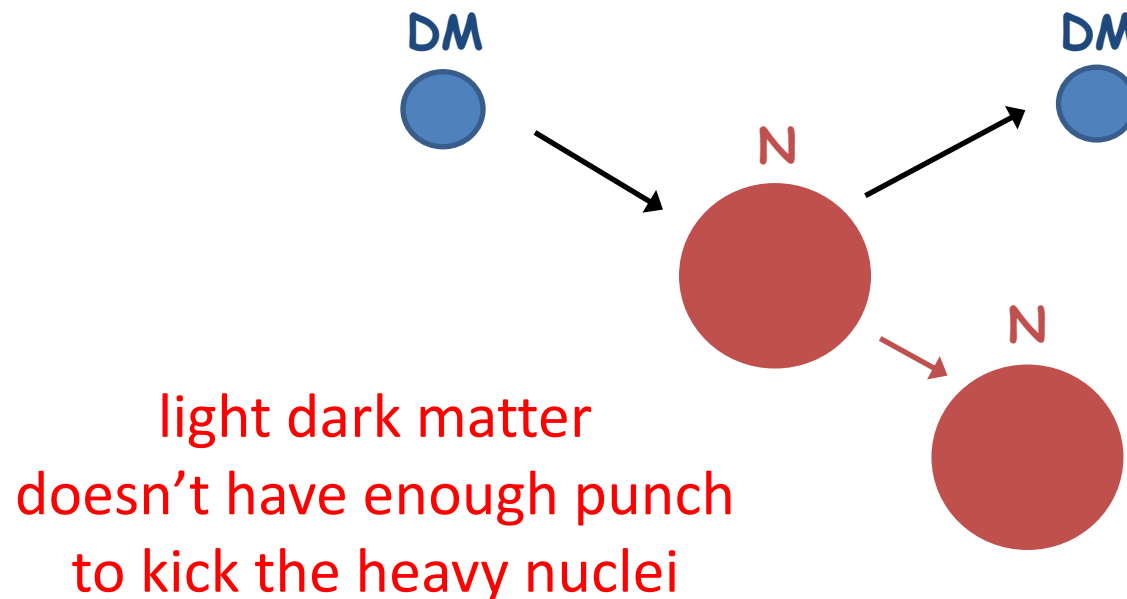

Lose sensitivity @ $O(\text{GeV})$ masses

New Avenues

Light dark matter: scatter off electrons!

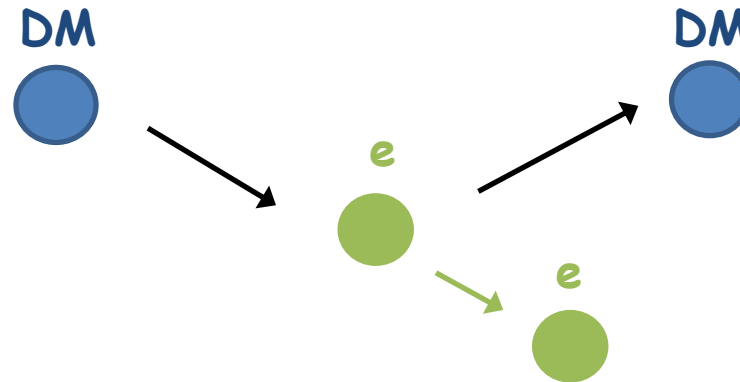

light dark matter
can give enough punch
to kick the light electrons

Energy guideline

Dark matter scattering: kinetic energy $m_{\text{DM}}v^2 \sim 10^{-6}m_{\text{DM}}$

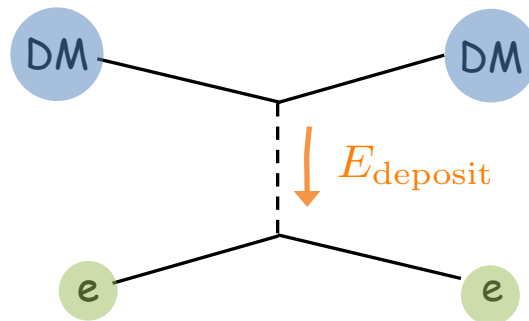
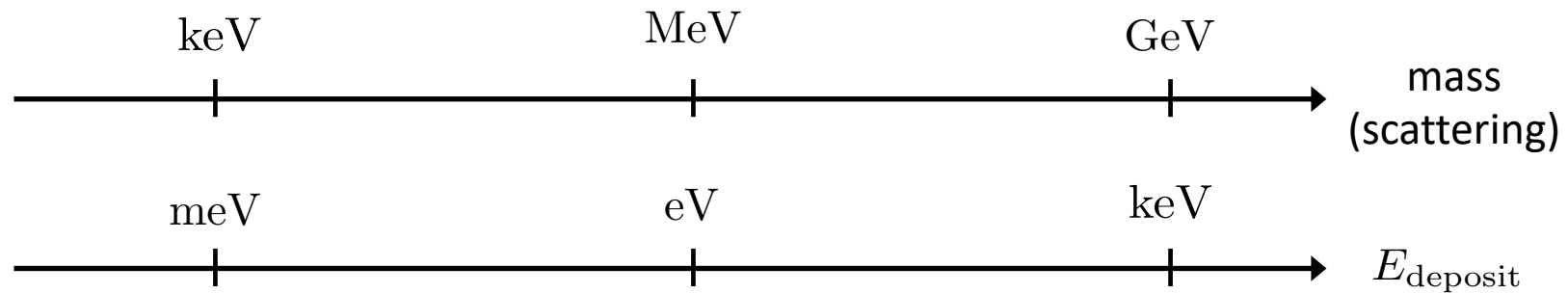

New proposals

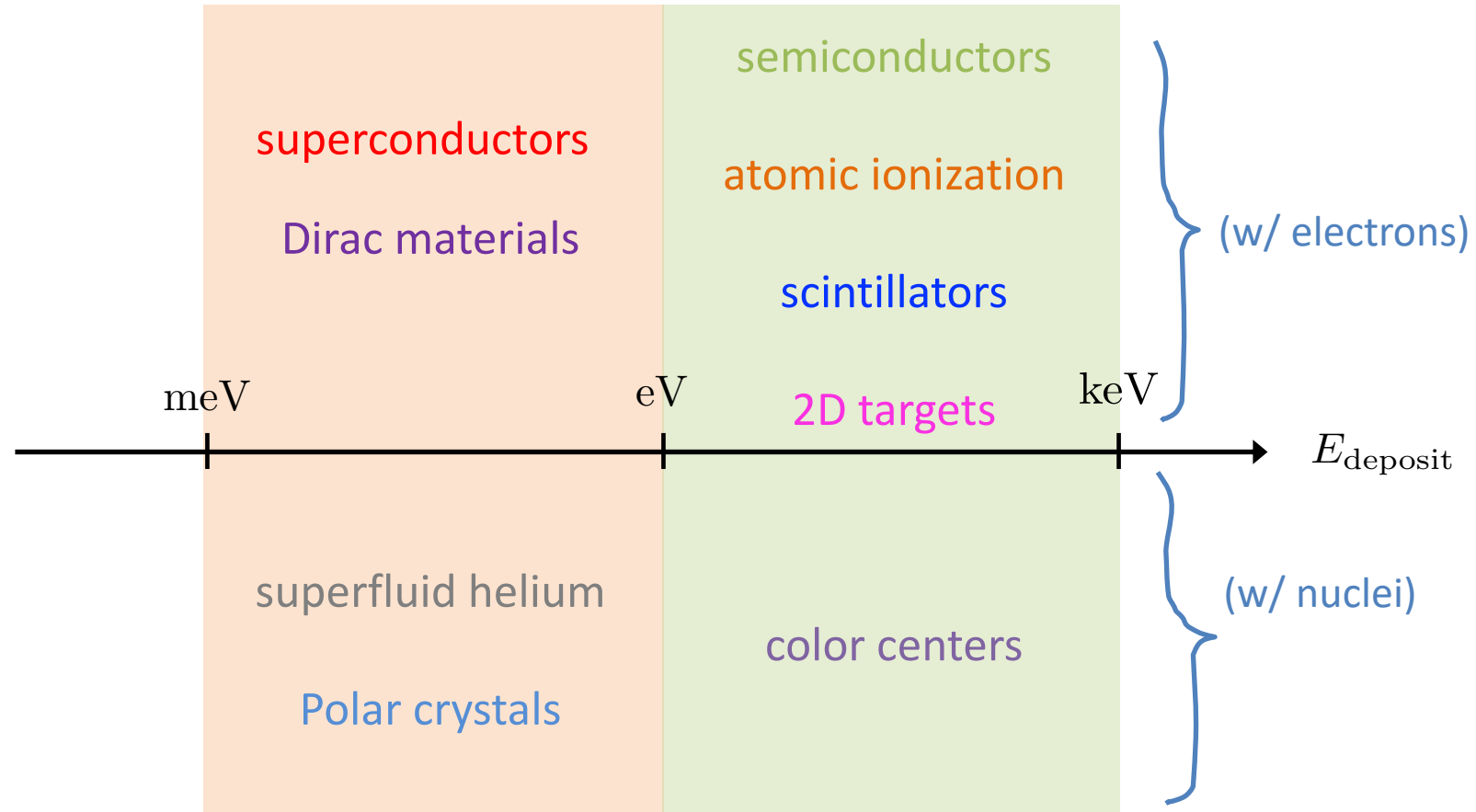

Explosion of interest and ideas in recent times

Ex. #1: First ideas

Atomic ionization

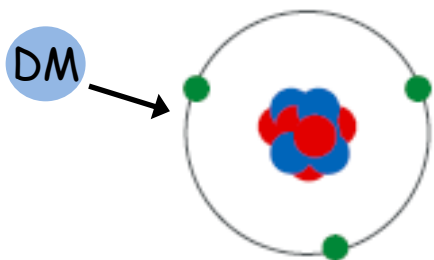

Xenon: ~ 12 eV

$$m_{\text{DM}} \gtrsim 10 \text{ MeV}$$

Essig, Mardon, Volansky, 2012

Semiconductors

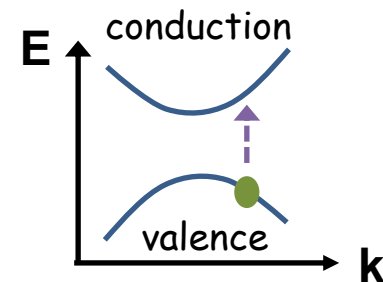

Ge, Si, Diamond, SiC: \sim eV

$$m_{\text{DM}} \gtrsim \text{MeV}$$

Essig, Mardon, Volansky, 2012
Graham, Kaplan, Rajendran, Walters, 2012
Kurinsky, Yu, YH, Blas, 2019
Griffin, YH, et al, 2020

Ex. #1: First ideas

Atomic ionization

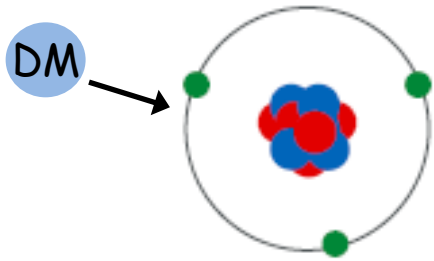

Xenon10/100/1T

$$m_{\text{DM}} \gtrsim 10 \text{ MeV}$$

Semiconductors

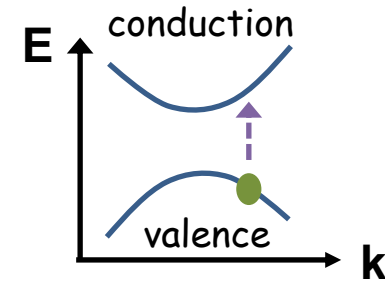

**SuperCDMS,
SENSEI**

$$m_{\text{DM}} \gtrsim \text{MeV}$$

Are being experimentally realized

Essig et al 2012 | Xenon100 2016 | Xenon1T 2020

SuperCDMS 2020 | SENSEI 2020

Ex. #1: First ideas

Atomic ionization

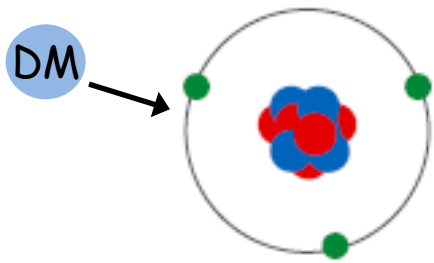

Xenon10/100/1T

$$m_{\text{DM}} \gtrsim 10 \text{ MeV}$$

Semiconductors

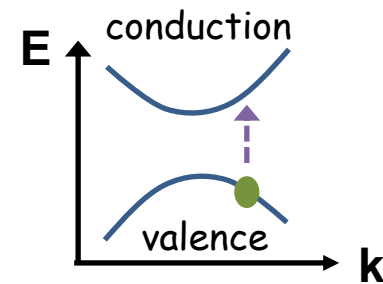

SuperCDMS,
SENSEI

$$m_{\text{DM}} \gtrsim \text{MeV}$$

Smaller masses?

Ex. #2: Superconductors

- Ground state = Cooper pairs;
Binding energy (gap) $\sim \text{meV}$ \longrightarrow $m_{\text{DM}} \sim \text{keV}$
- The idea:
DM scatters with Cooper pairs, deposits enough energy,
breaks Cooper pairs \rightarrow detect

Excitations

Excitation concentration
philosophy

YH, Zhao, Zurek, PRL 2015
YH, Pyle, Zhao, Zurek, JHEP 2015

Sensor + target
philosophy

YH, Charaev, Nam, Verma, Colangelo,
Berggren, PRL 2019

Ex. #2: Superconductors

- Ground state = Cooper pairs;
Binding energy (gap) $\sim \text{meV}$ \longrightarrow $m_{\text{DM}} \sim \text{keV}$
- The idea:
DM scatters with Cooper pairs, deposits enough energy,
breaks Cooper pairs \rightarrow detect

Excitations

Excitation concentration
philosophy

YH, Zhao, Zurek, PRL 2015
YH, Pyle, Zhao, Zurek, JHEP 2015

Sensor + target
philosophy

YH, Charaev, Nam, Verma, Colangelo,
Berggren, PRL 2019

Ex. #2: Superconductors

- Superconducting Nanowire Single Photon Detectors (SNSPDs)

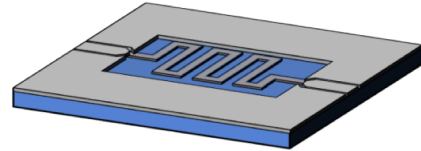

Broadly used in quantum information science

- Ram an electron, create a hotspot, electrons diffuse away, resistive region across the nanowire → voltage pulse

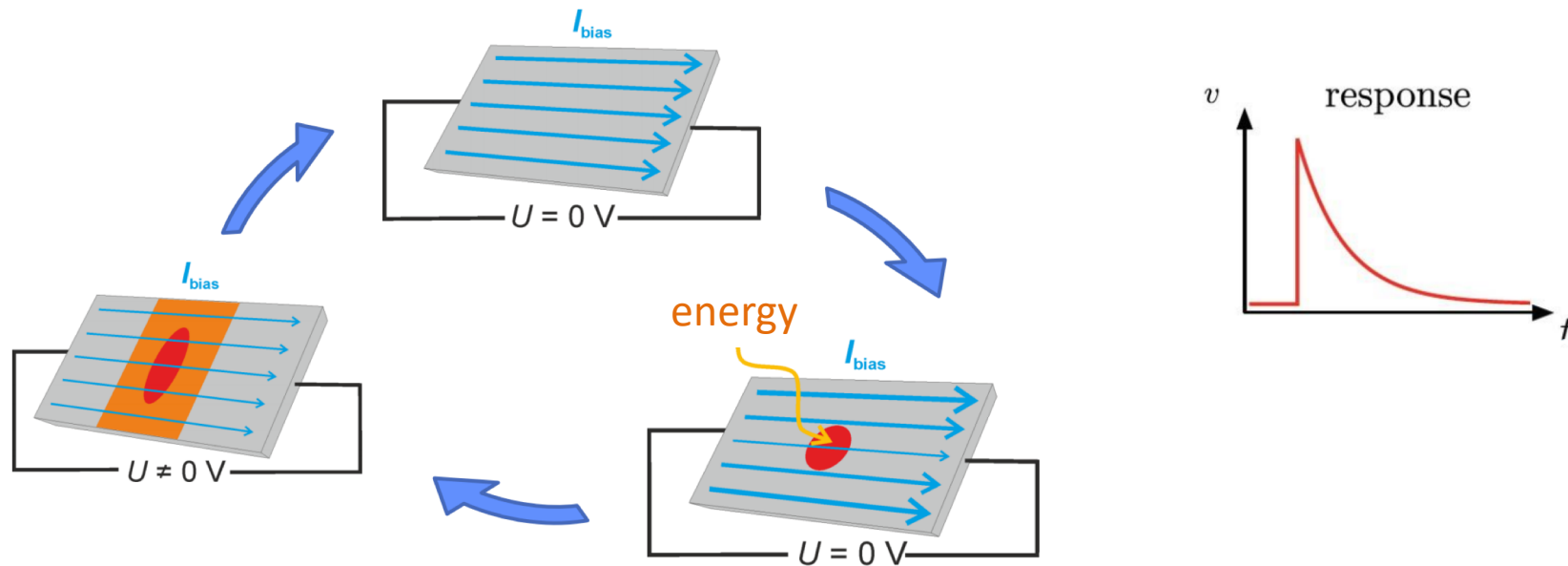

Ex. #2: Superconductors

Use as simultaneous **target + sensor** (& multiplex)

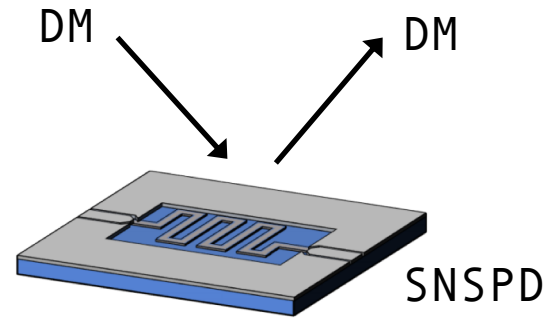

[Existing prototype]

Directional Info?

Lose directional information
if detecting secondaries

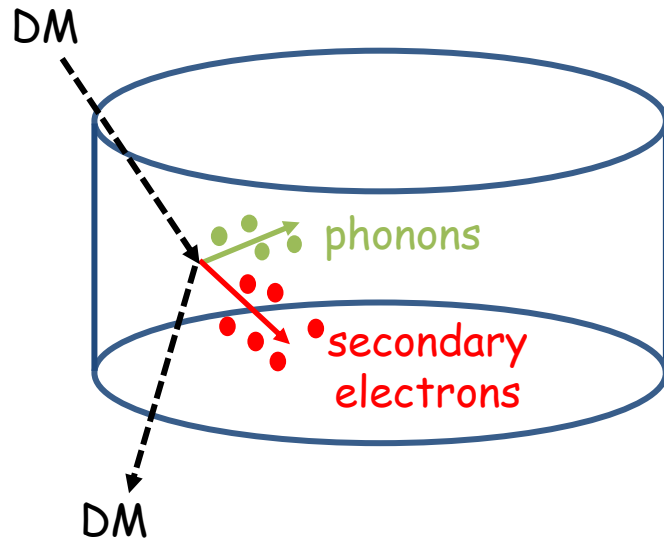

e.g. semiconductors,
bulk superconductors

Retain directional information
if observe primary!

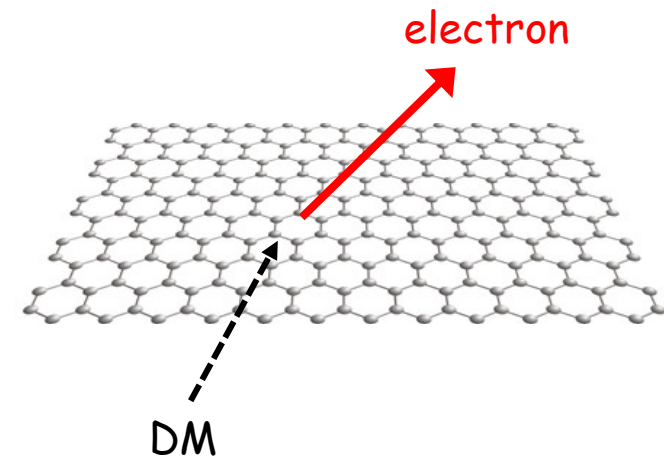

2D targets;
graphene (& SNSPDs)

Ex. #3: Graphene

Dark matter scatters with valence electrons, deposits enough energy, ejects electron \rightarrow detect

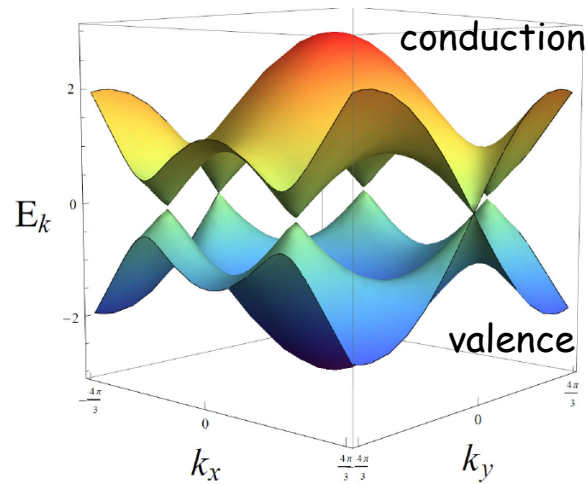

$$E_{\text{eject}} \sim \mathcal{O}(\text{few eV})$$
$$\Rightarrow m_{\text{DM}} \gtrsim \text{MeV}$$

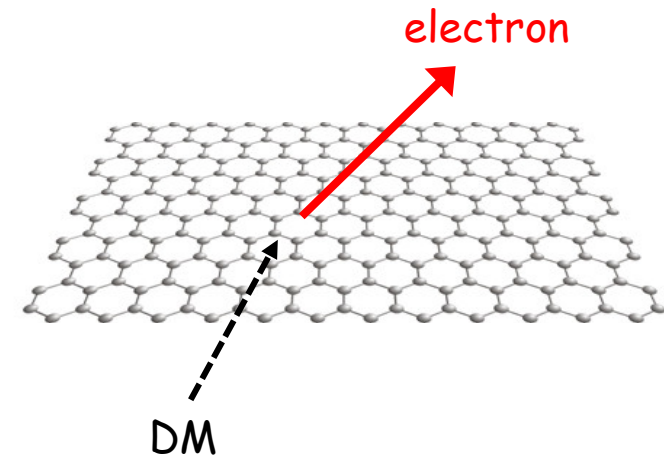

Eject and detect philosophy

YH, Kahn, Lisanti, Tully, Zurek, 2017

Ex. #3: Graphene

Electron follows incoming dark matter direction.
Naturally gives forward/backward discrimination
(separates signal from background)

Electron detected

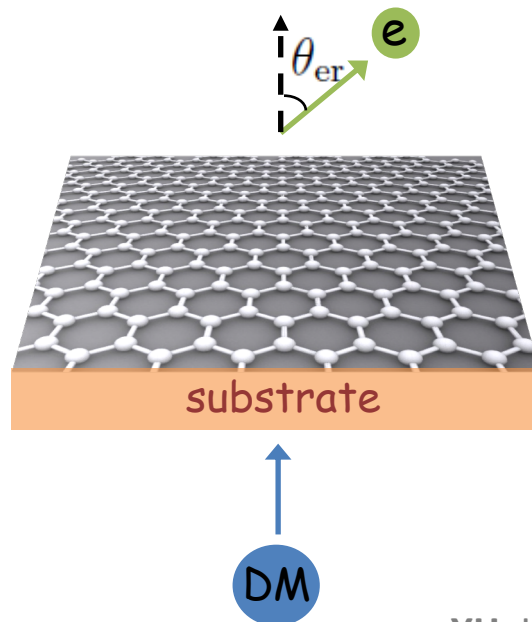

electron not detected

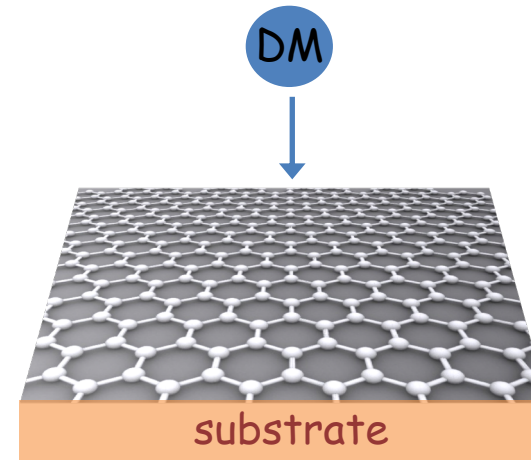

12 hours later

YH, Kahn, Lisanti, Tully, Zurek, 2017

Ex. #3: Design Concept

- ~ 0.5 kg graphene = area of Jerusalem old city = billions of cm^2 crystals
- Compact geometry: large mass via many stacks

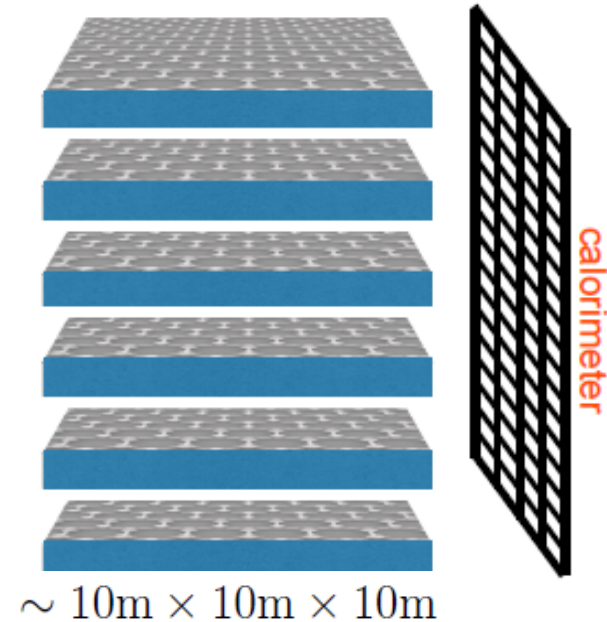
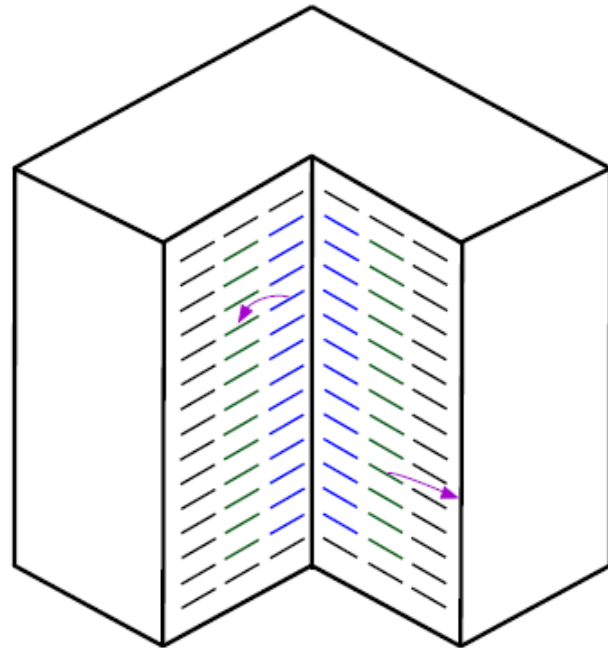

Implement in PTOLEMY

Experiment to detect relic neutrinos via capture on tritium.

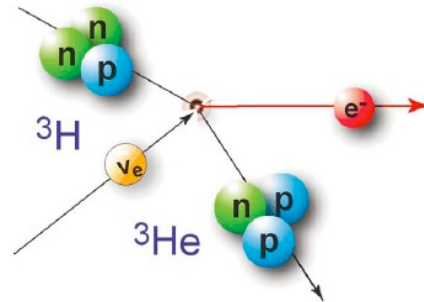

Betts et al, 2013

Will use tritiated graphene (~ 0.5 kg).

Borrow pure (un-tritiated) graphene for dark matter experiment!

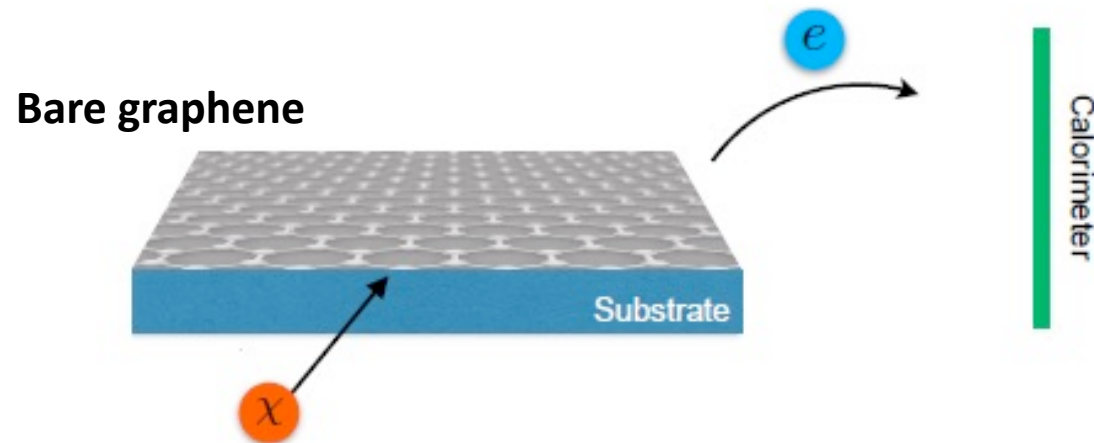

PTOLEMY World-Wide Collaboration



PTOLEMY: A Proposal for Thermal Relic Detection of Massive Neutrinos and Directional Detection of MeV Dark Matter

Compute Event Rate

[Events/unit time/unit mass]

$$\text{Rate} \propto \underbrace{\frac{1}{\rho_{\text{target}}}}_{\text{Target density}} \times \underbrace{\frac{\rho_{\text{DM}}}{m_{\text{DM}}} \times v_{\text{DM}}}_{\text{dark matter flux (astrophysics)}} \times \underbrace{\text{target properties}}_{\text{condensed matter physics}} \times \underbrace{\sigma_{\text{int}}}_{\text{particle physics}}$$

The diagram illustrates the components of the event rate equation. A red arrow points from the units '[Events/unit time/unit mass]' down to the equation. The equation is: Rate ∝ (1/ρ_{target}) × (ρ_{DM}/m_{DM} × v_{DM}) × target properties × σ_{int}. Brackets and arrows link parts of the equation to labels: a green bracket under 1/ρ_{target} points to 'Target density'; a purple bracket under ρ_{DM}/m_{DM} × v_{DM} points to 'dark matter flux (astrophysics)'; an orange bracket under 'target properties' points to 'condensed matter physics'; and a blue bracket under σ_{int} points to 'particle physics'.

Scattering Reach

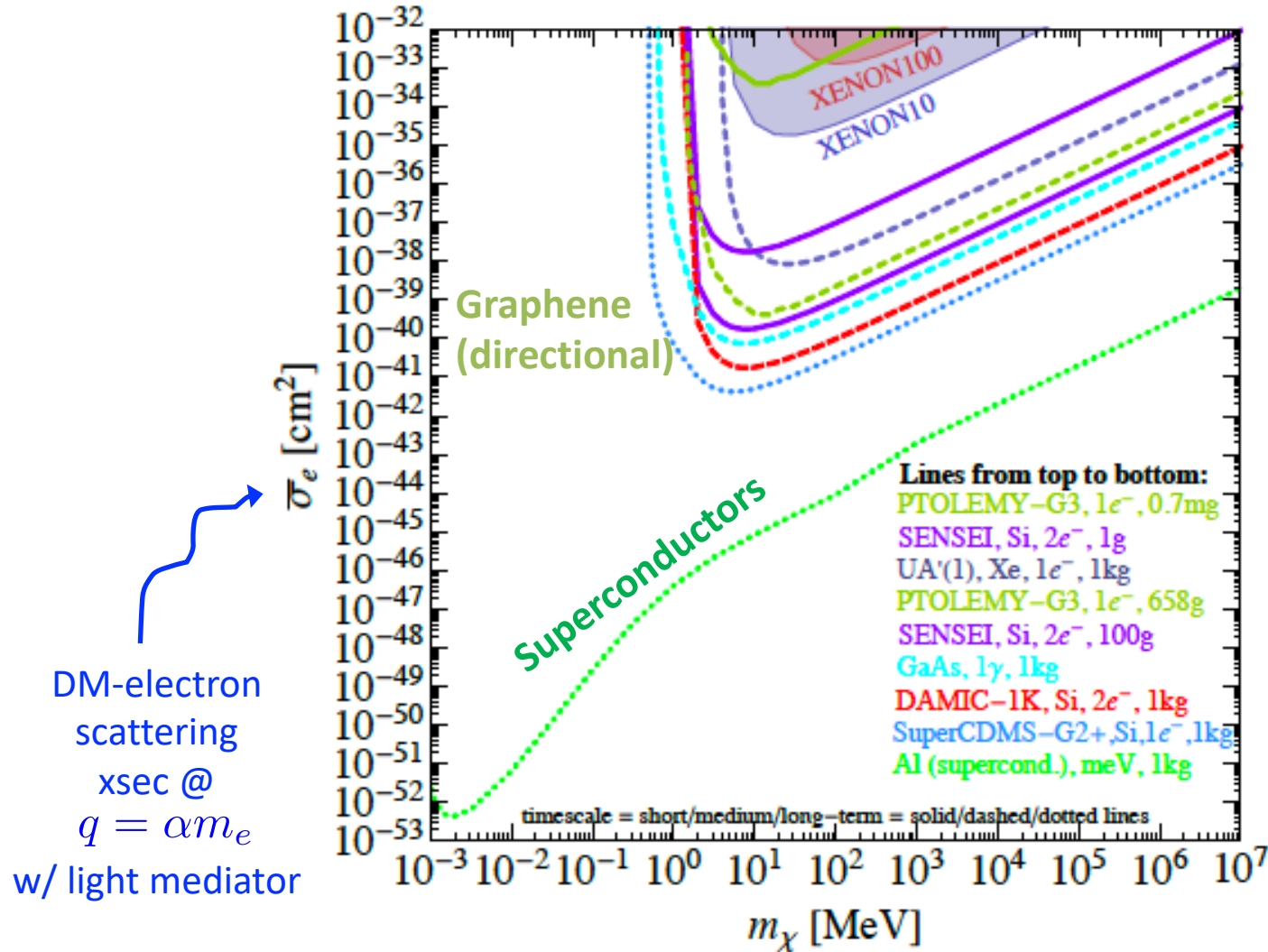

[a few events in
kg-year
exposure]

Amazing
reach!

Existing Prototype Device

WSi SNSPD, 4.3 nanogram, 0.8 eV threshold,
no dark counts in 10000 seconds (~3 hours)

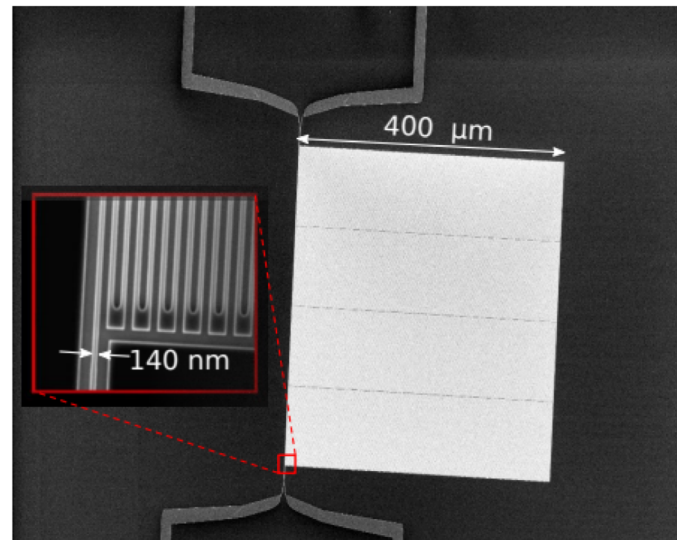

By now have 180 hours of data

YH, Charaev, Nam, Verma, Colangelo, Berggren, PRL 2019 + w/ Lehmann 2110.01586

Scattering Reach

Colored curves:
Large array, low
threshold, low
dark count
SNSPDs

DM-electron
scattering
xsec @
 $q = \alpha m_e$
w/ light mediator

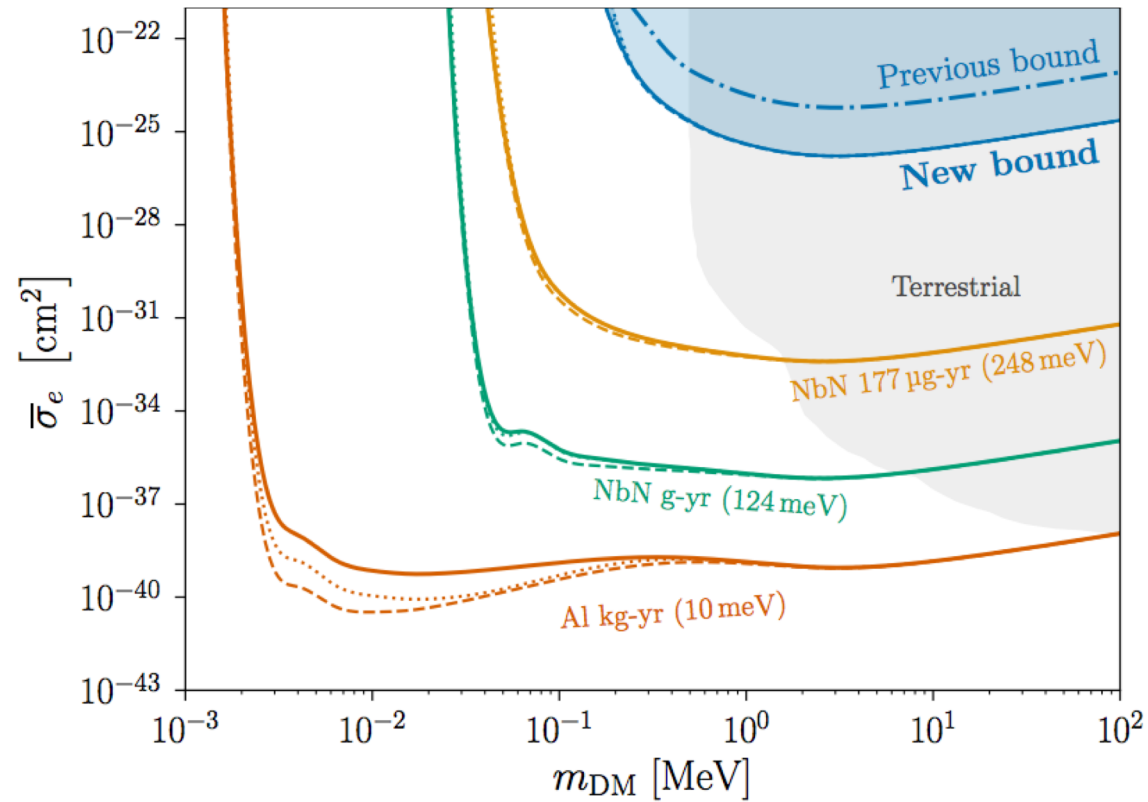

Non-solid
curves:
geometry
effects

Lasenby, Prabhu 2021

YH, Charaev, Nam, Verma, Colangelo, Berggren, PRL 2019 + w/ Lehmann 2110.01586

Pushing Thresholds Lower

Single-photon detection in the mid-infrared up to 10 micron wavelength using tungsten silicide superconducting nanowire detectors

V. B. Verma,^{1, a)} B. Korzh,^{2, b)} A. B. Walter,² A. E. Lita,¹ R. M. Briggs,² M. Colangelo,³ Y. Zhai,¹ E. E. Wollman,² A. D. Beyer,² J. P. Allmaras,² B. Bumble,² H. Vora,¹ D. Zhu,³ E. Schmidt,² K. K. Berggren,³ R. P. Mirin,¹ S. W. Nam,¹ and M. D. Shaw²

¹⁾*National Institute of Standards and Technology, Boulder, CO, USA.*

²⁾*Jet Propulsion Laboratory, California Institute of Technology, 4800 Oak Grove Dr., Pasadena, CA, USA*

³⁾*Department of Electrical Engineering and Computer Science, Massachusetts Institute of Technology, Cambridge, MA, USA.*

(Dated: 21 December 2020)

We developed superconducting nanowire single-photon detectors (SNSPDs) based on tungsten silicide (WSi) that show saturated internal detection efficiency up to a wavelength of 10 μm . These detectors are promising for applications in the mid-infrared requiring ultra-high gain stability, low dark counts, and high efficiency such as chemical sensing, LIDAR, dark matter searches and exoplanet spectroscopy.

**Demonstrated WSi SNSPDs
w/ 125meV energy threshold**

arXiv:2012.09979

New Formalism

DM-electron scattering in any material
is determined by the dielectric function.

For any DM interaction that couples to electron density

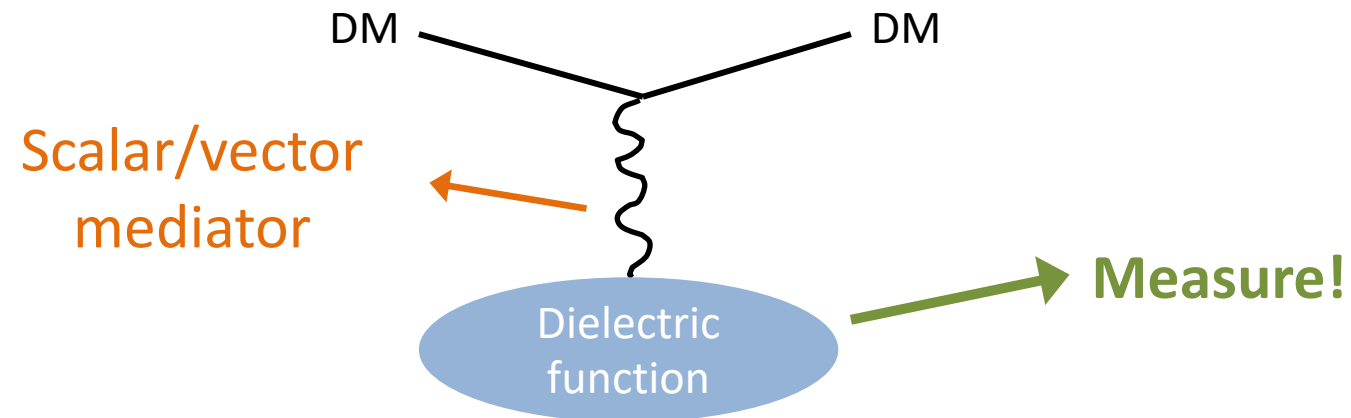

YH, Kahn, Kurinsky, Lehmann, Yu, Berggren, PRL 2021

[See also arXiv: 2101.08275]

New Formalism

Automatically includes many-body effects of the material

Collective modes (e.g. plasmon),
not just single particle excitations

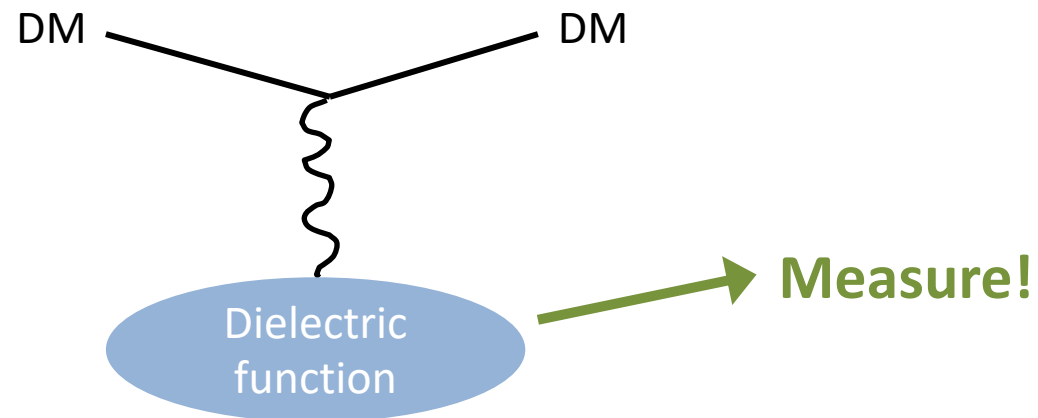

Identify promising materials for DM detection

YH, Kahn, Kurinsky, Lehmann, Yu, Berggren, PRL 2021

Ex. #4: Heavy Fermions

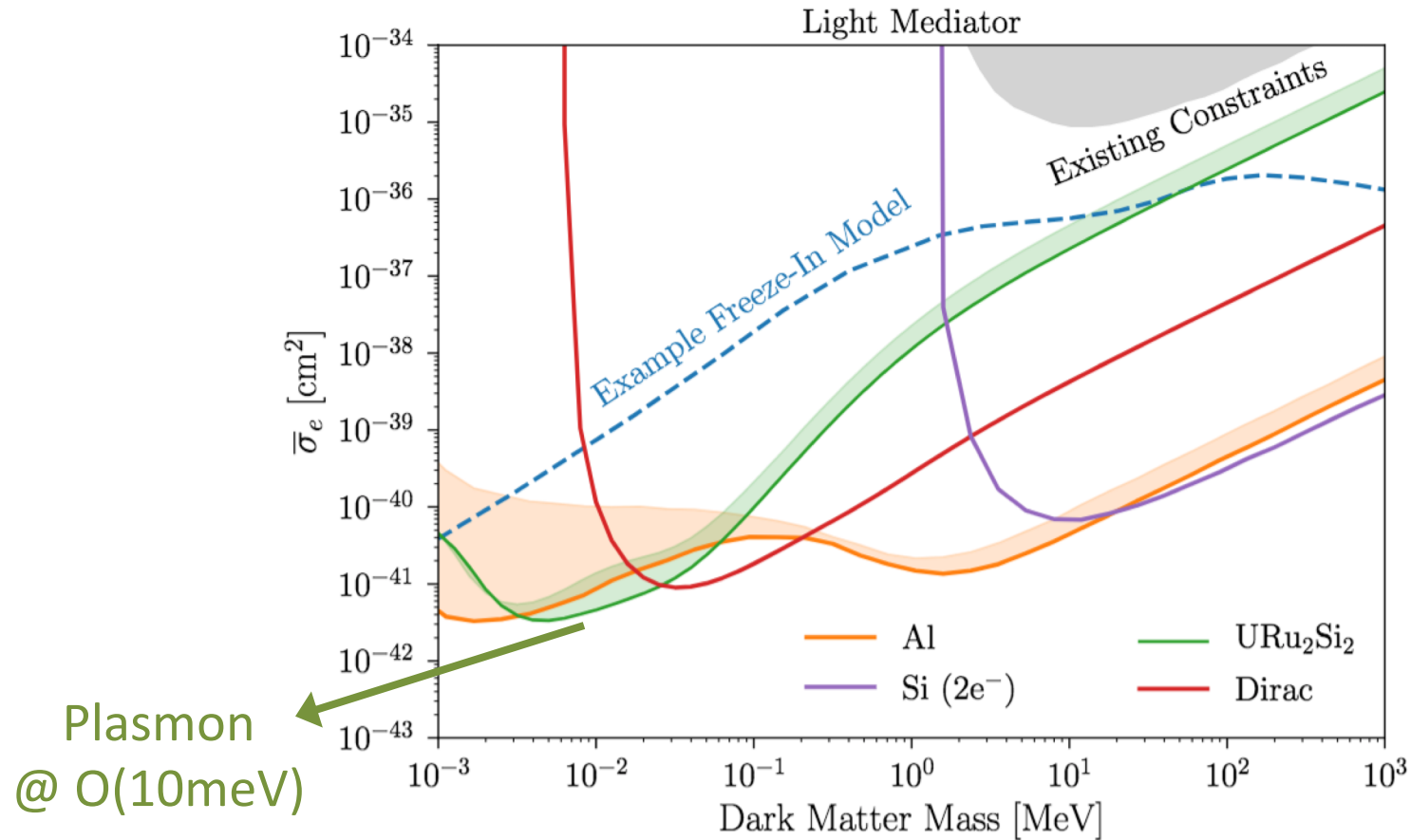

Identify promising materials for DM detection

YH, Kahn, Kurinsky, Lehmann, Yu, Berggren, PRL 2021



Any given target material can go even further.

Absorption vs. Scattering

Dark matter scattering: kinetic energy $m_{\text{DM}}v^2 \sim 10^{-6}m_{\text{DM}}$

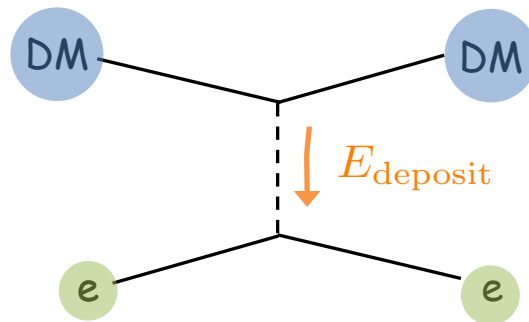
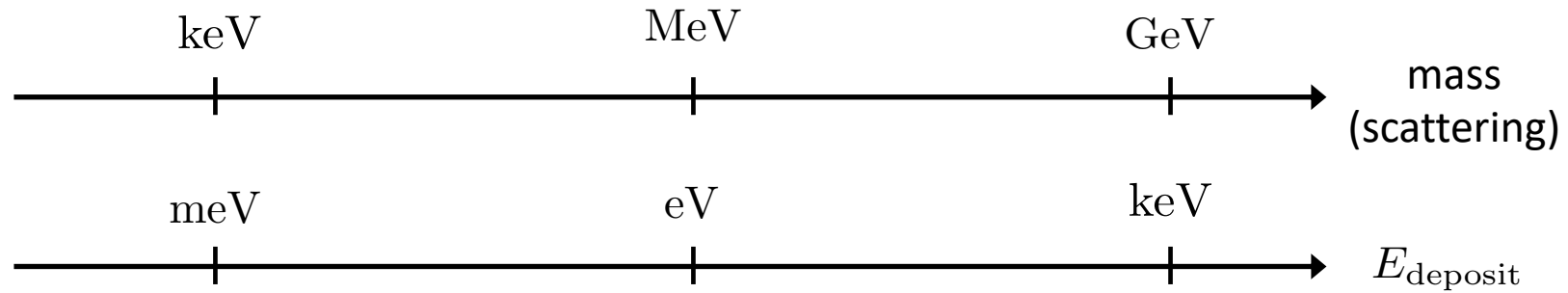

Absorption vs. Scattering

Dark matter absorption: all the mass-energy m_{DM}

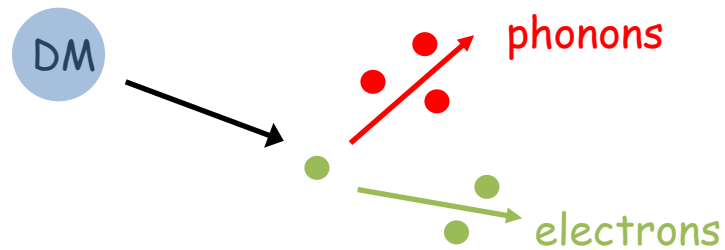
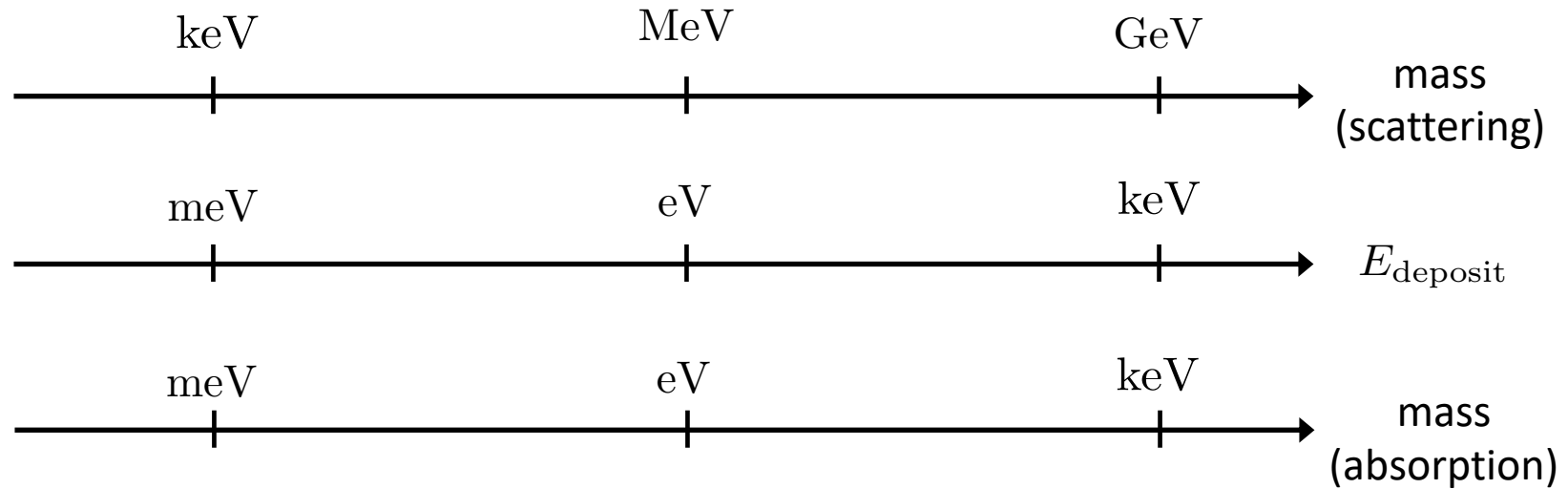

Absorption vs. Scattering

Two (mass ranges) for the price of one :-)

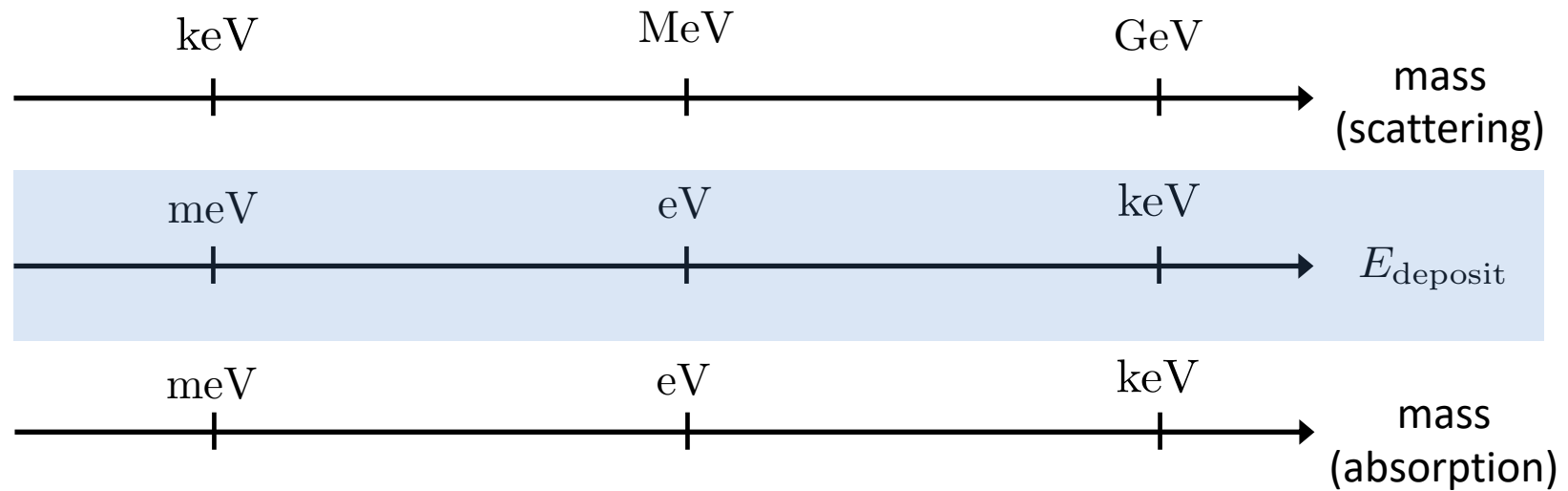

Absorption Reach

[projections for kg-year]

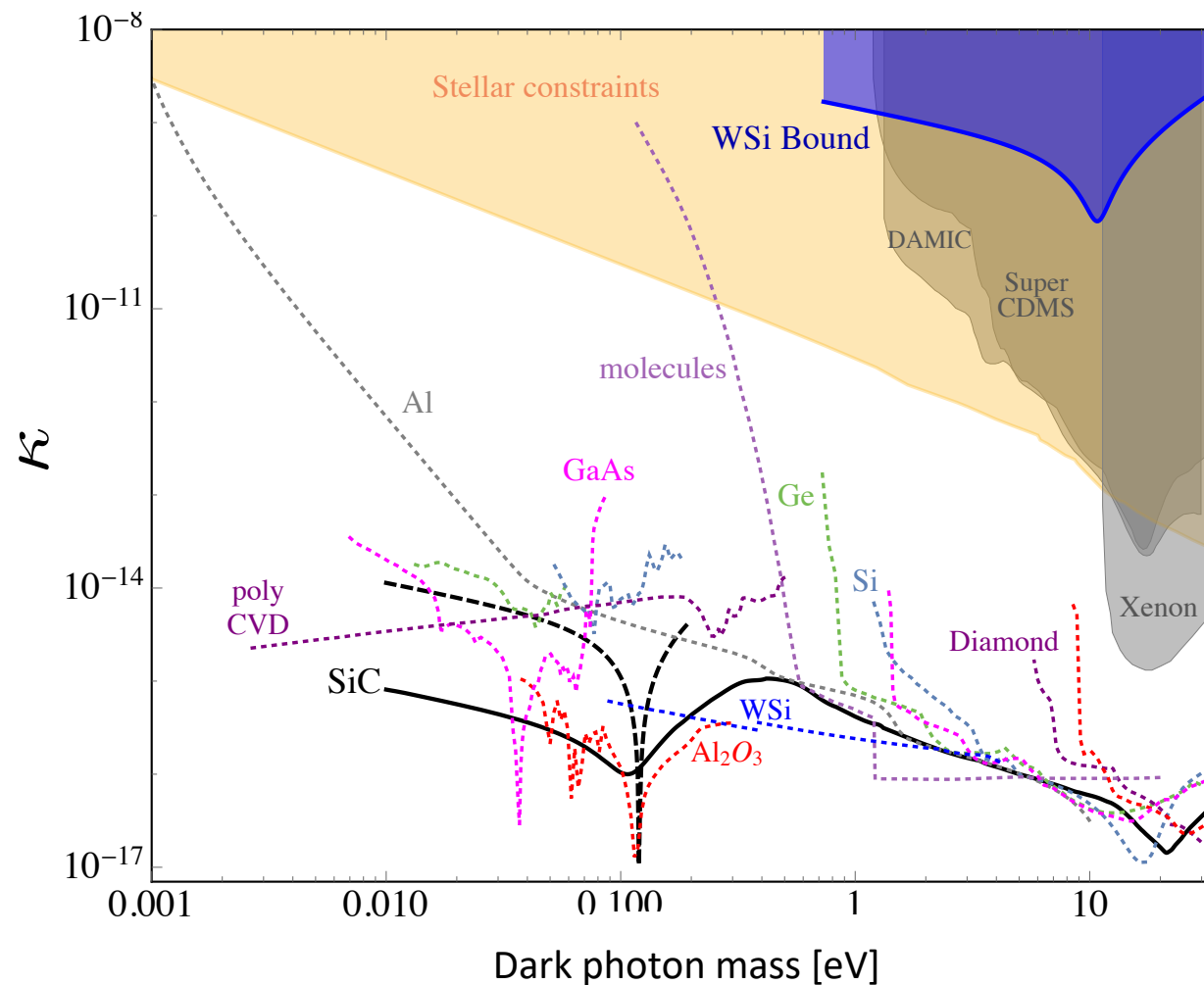

New bound:
WSi SNSPD
prototype
4.3ng in 180
hours

Kurinsky, Yu, YH, Blas, PRD 2019
Griffin, YH, et al, 2020
YH et al, 2021



Wish List

- Single/rare-event sensitivity
- Build up to large target mass: many small units ok & multiplex
- Target can/cannot be the sensitive sensor itself
- Small gap and low thresholds
- Low dark counts ideally
- Directionality a major plus
- Data



**Think
detection
philosophy
& target
& sensor**

Outlook

- Lots of activity for light dark matter
- Theory \leftrightarrow experiment
- By no means exhausted...
- It's ok for an idea to seem crazy at first
- The best ideas might still be ahead

Prospects

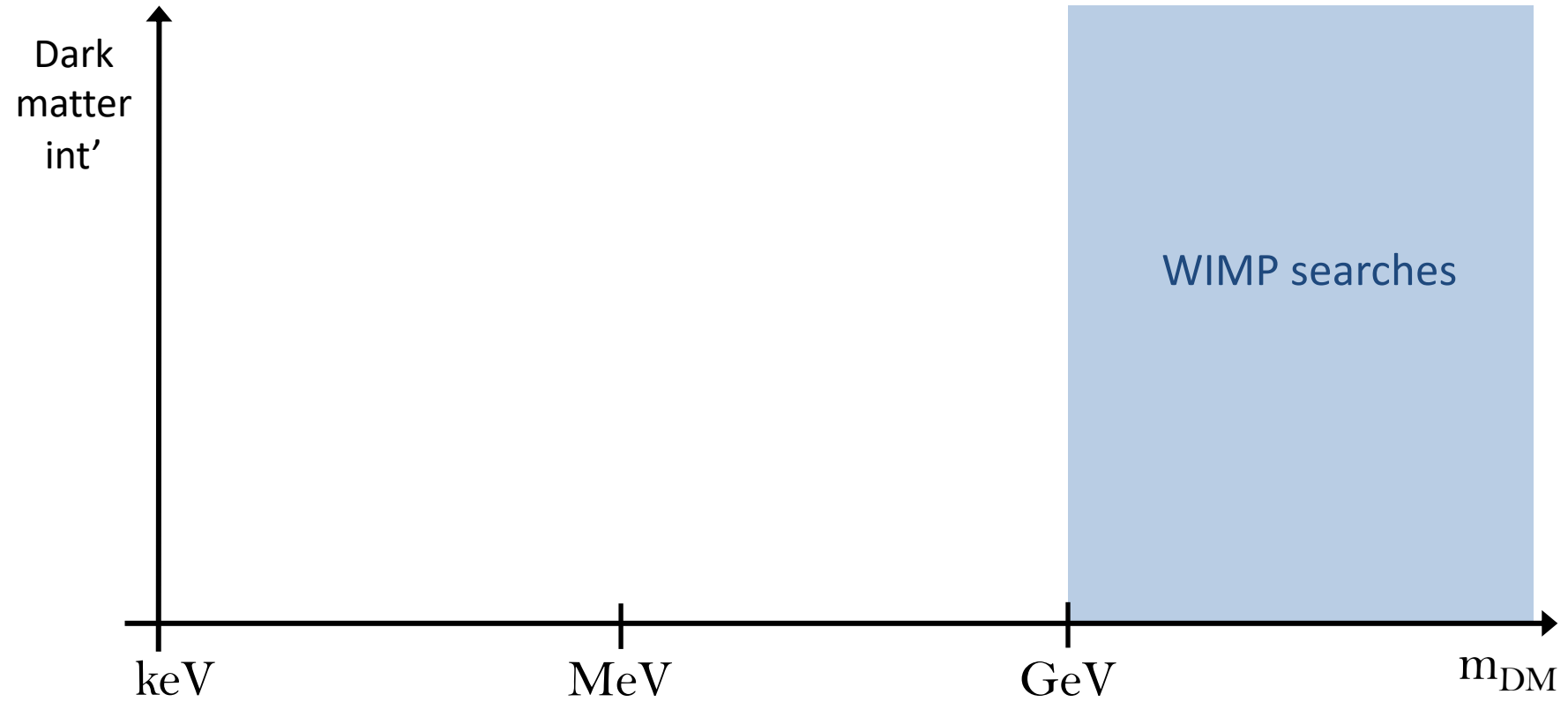

Prospects

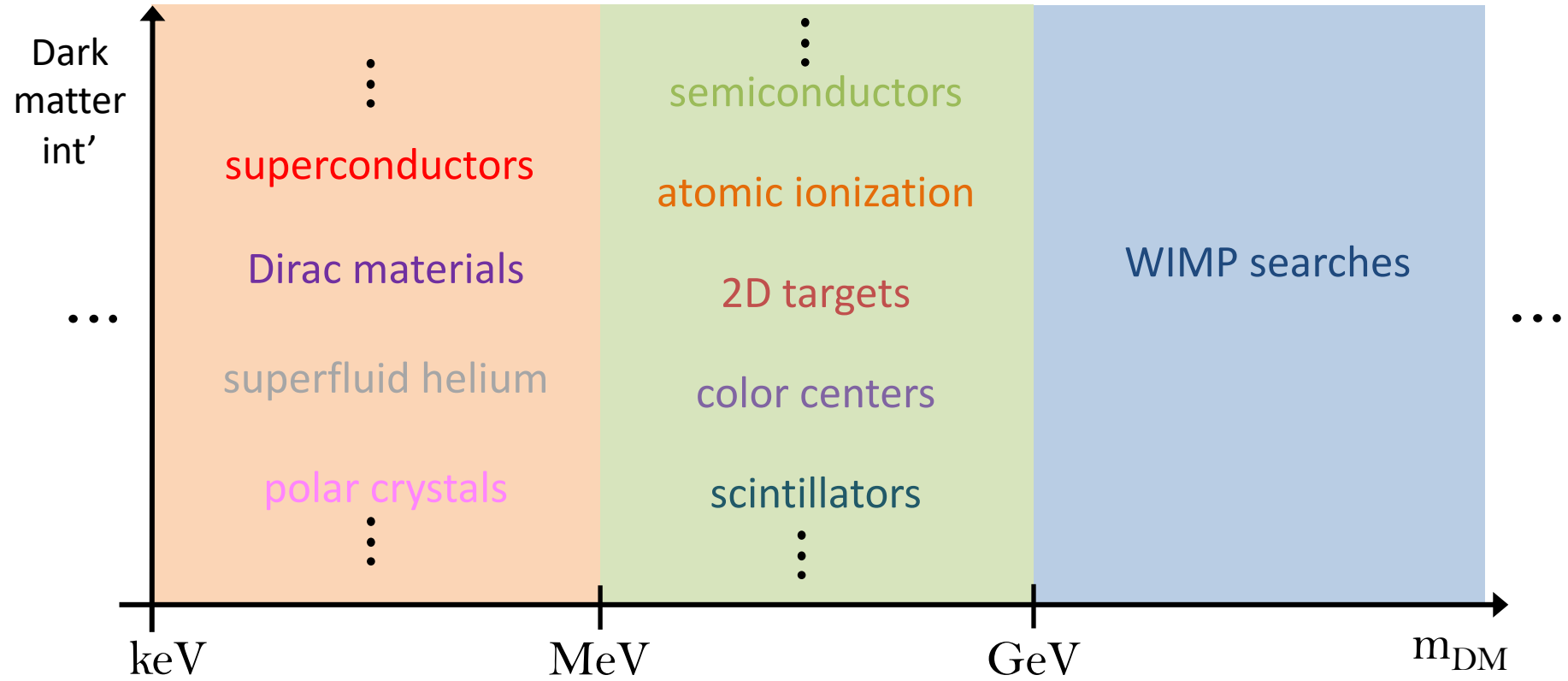

Burgeoning field in recent years

Prospects

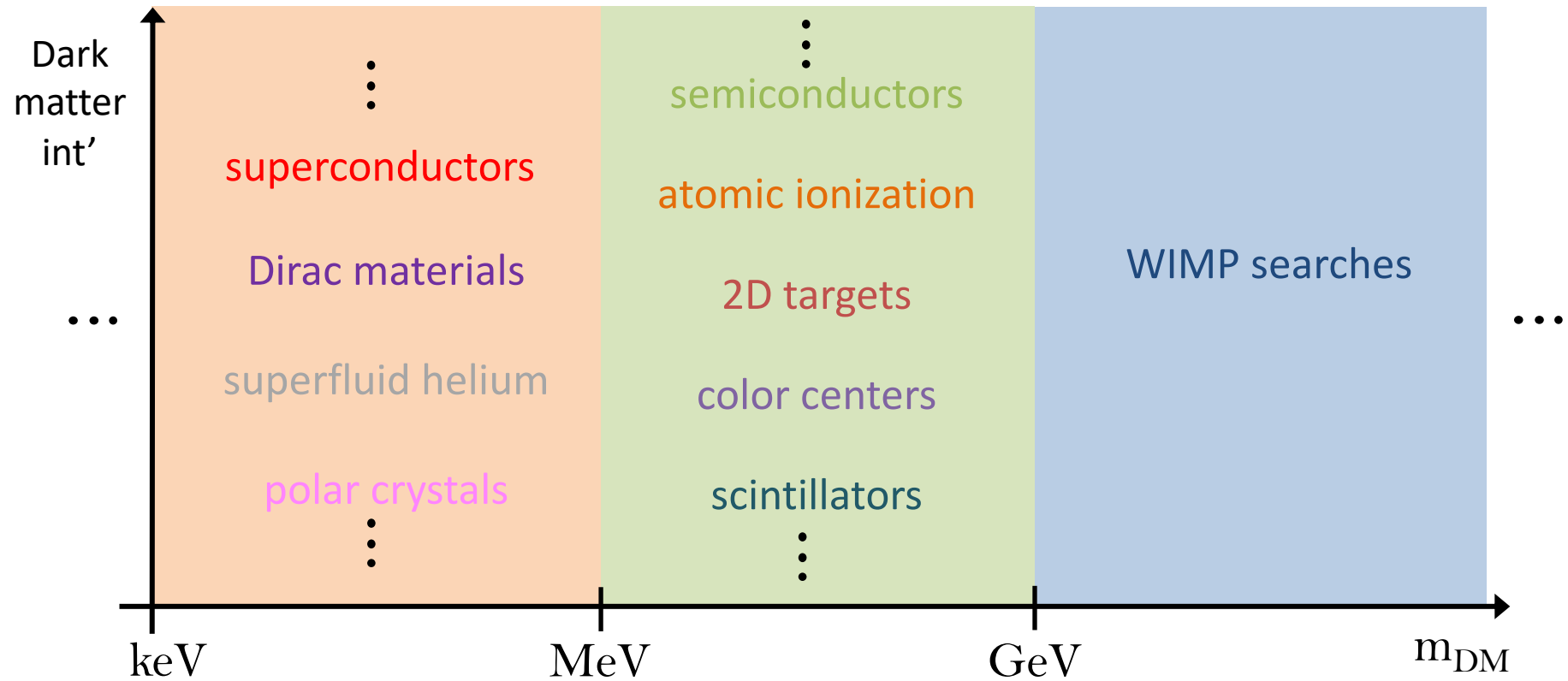

Experimentalists are going after these ideas now!

Prospects

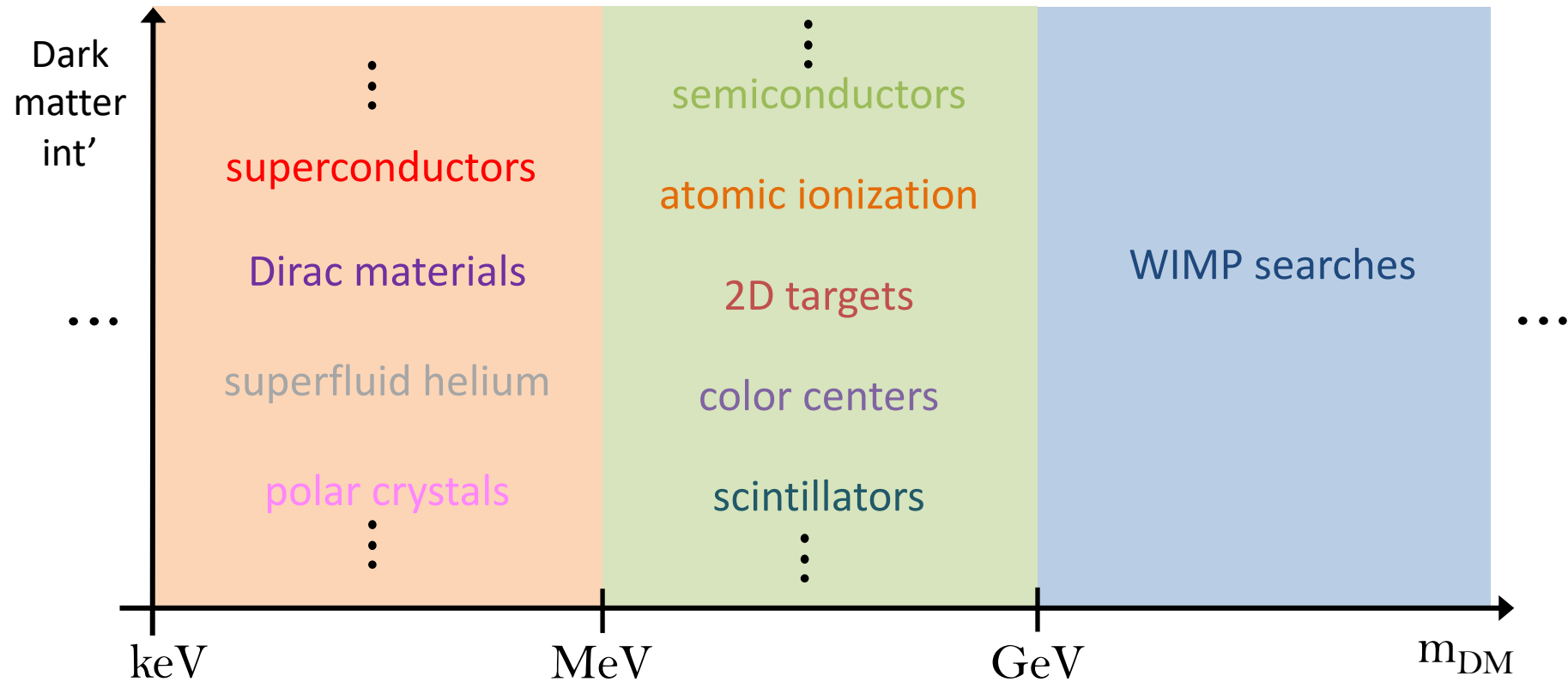

Interface particle physics/condensed matter physics/
quantum information science/precision measurements



If you have any (crazy) new ideas,
please be in touch :-)

Thanks!

