



SPL cryomodule specification:

Goals of the meeting

V.Parma, TE-MSD



Goal of today's meeting

- **Identify** and **address** still **outstanding** cryomodule **design** **specification** **issues**
- **Address** the **specific requirements** related to the **test program** of the short cryomodule at CERN (for ex. : windows for in-situ intervention, need for diagnostics instrumentation, etc.).
- **Converge** towards a **technical specification** to allow the continuation of the engineering of the short cryomodule, or **identify road-maps** to settle outstanding issues.

Chairperson: Vittorio Parma (CERN, TE/MS-C)

Scientific secretary: Arnaud Vande Craen (CERN, TE-MS-C)



Agenda

Tuesday 19 October 2010

- 09:00 - 09:10 **Welcome** 10'
Speaker: Roland Garoby (CERN)
- 09:10 - 09:30 **Goals of the meeting** 20'
Speaker: Vittorio Parma (CERN)
- 09:30 - 10:00 **Open questions from IN2P3/CNRS** 30'
Speaker: Patxi DUTHIL (IPNO - IN2P3 - CNRS)
- 10:00 - 10:15 **Coffee break** (Cafeteria Bldg 30 7th floor)
- 10:15 - 10:45 **Cavities and related equipment (tuner, HOM, magnetic shields)** 30'
Speaker: Wolfgang Weingarten (CERN)
- 10:45 - 11:15 **RF system (powering, distribution, coupling, control)** 30'
Speaker: Olivier Brunner (CERN)
- 11:15 - 11:45 **Cryogenic requirements and test plans** 30'
Speaker: Udo Wagner
- 11:45 - 12:00 **Cryogenic test infrastructure in SM18** 15'
Speaker: TBD
- 12:00 - 14:00 **Lunch break** (---)
- 14:00 - 14:30 **Cryomodule development for Project X** 30'
Speaker: Jim Kerby (Fermi National Accelerator Laboratory (FNAL))
- 14:30 - 16:00 **Wrapping-up session** 1h30'
- 16:00 - 16:15 **Coffee break** (Cafeteria bldg 30 7th floor)
- 16:15 - 16:45 **Conclusions** 30'
Speaker: Vittorio Parma (CERN)



Background information



Short cryo-module: Goal & Motivation

Goal:

- Design and construct a $\frac{1}{2}$ -length cryo-module for 4 $\beta=1$ cavities (as close as possible to a machine-type cryomodule)

Motivation:

- Test-bench for RF testing on a multi-cavity assembly driven by a single or multiple RF source(s)
- Enable RF testing of cavities in horizontal position, housed in machine-type configuration (helium tanks with tuners, and powered by machine-type RF couplers)
- Validate by testing critical components like RF couplers, tuners, HOM couplers in their real operating environment



Cryostat-related goals:

- Learning of the critical assembly phases:
 - From clean room assembly of cavities to a cryomodule
 - Alignment/assembly in the cryostat;
- Proof of concept of “2-in-1” RF coupler/cavity supporting:
 - Fully integrated RF coupler: assembly constraints
 - Active cooling effect on cavity alignment
- Operation issues:
 - Cool-down/warm-up transients
 - Thermo-mechanics and alignment, vibrations
 - Heat loads



Instrumentation: cryostat-specific needs

- Alignment: Wire Position Monitor (WPM) type system
 - On-line monitoring movements and vibrations of the Cold Mass (CM) during cool down and steady state operation
 - Requires WPM supports of helium vessel
 - Routing of coax cables through cryostat (4 per measurement point)
- Calorimetric measurements
 - T gauges in helium bath (1 per cavity)
 - 25 W electrical heaters in helium bath (1 per cavity)

$\beta=1$ cryo-module in SPL layout

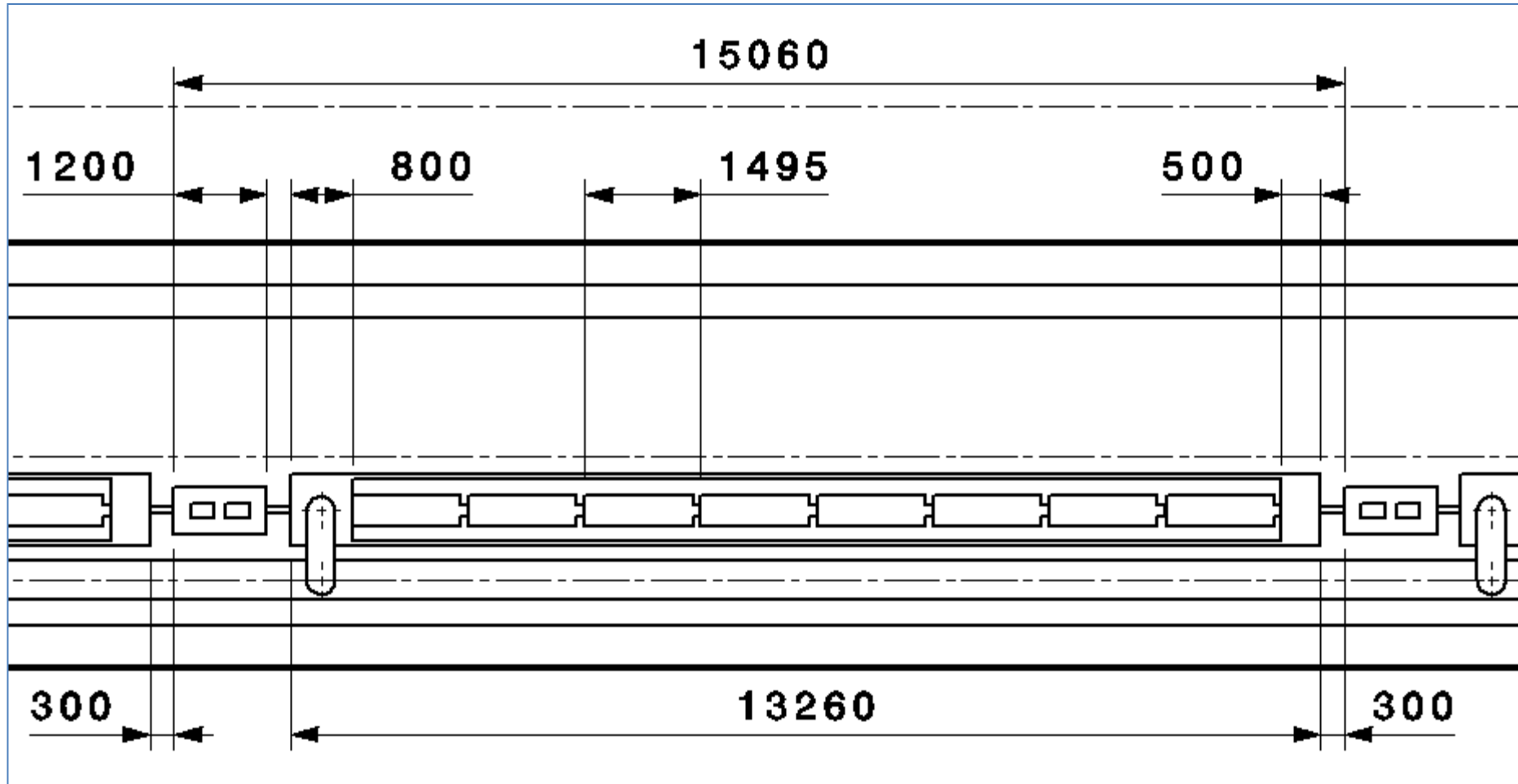

Moving from 8 to a 4-cavity design

Cryo-module Design Strategy:

- Cryo design for an 8-cavity machine cryomodule:
 - Cryogenics (p,T, heat loads, mass flows...)
 - Inner cryo lines for a fully segmented machine layout:
 - Individual cryo feeding, He vapours pumping, cryo control
 - Pipe IDs, pressure drops, T margins,
 - Control equipment (valves and instrumentation)
 - Design for 1.7% tunnel slope (test 0%-2%)
- *Design for Manufacture* for a small-to-medium number of cryomodule (typically ~50 units)
 - Mechanical design, construction and assembly
 - Alignment goals for machine-type cryomodules





“Dressed” Cavity (CERN mods to CEA’s design)

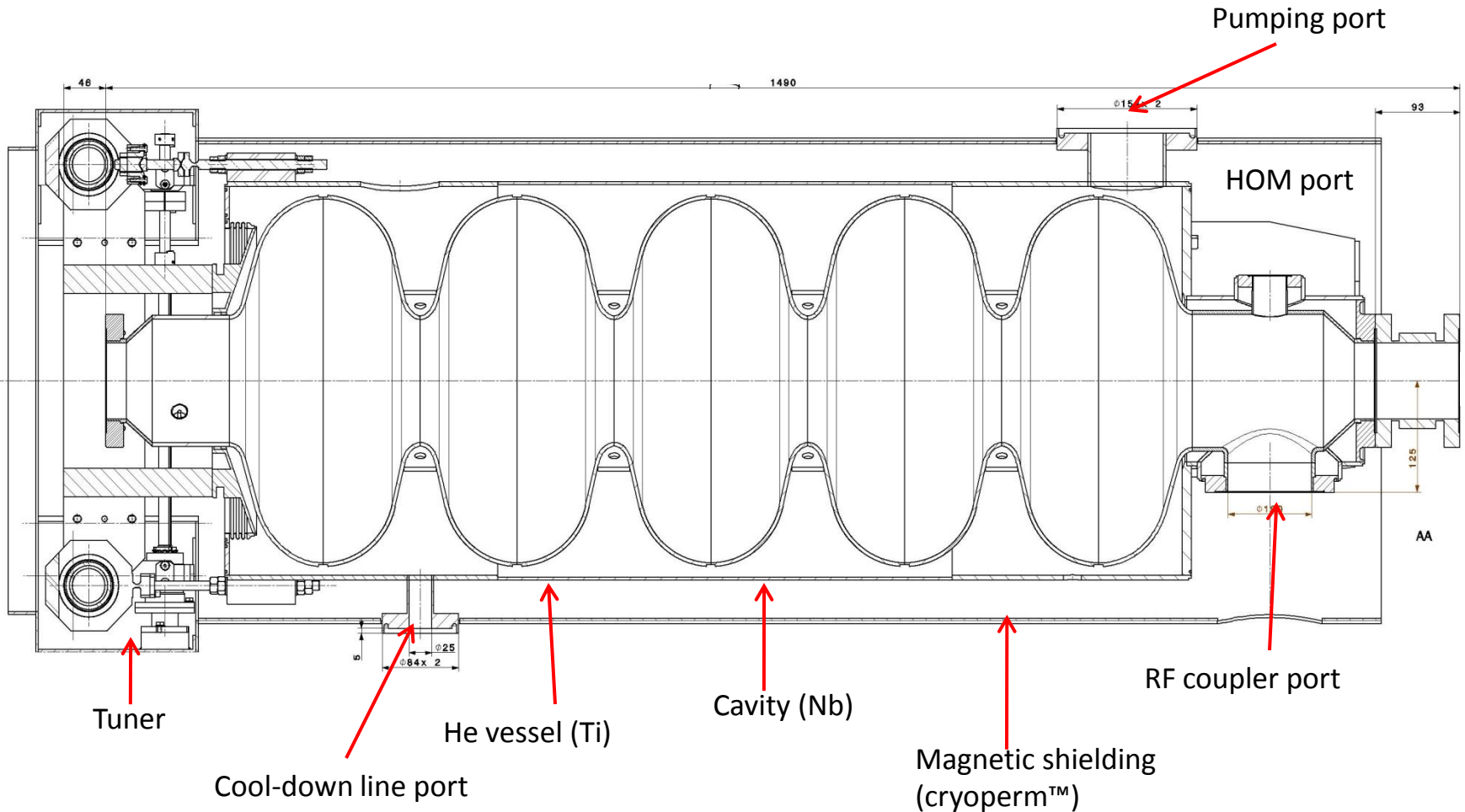

Includes specific features for cryo-module integration (inter-cavity supports, cryogenic feeds, magnetic shielding ...)

Cavity Supporting System: alignment

Transversal position specification

BUDGET OF TOLERANCE			
Step	Sub-step	Tolerances (3σ)	Total envelopes
Cryo-module assembly	Cavity and He vessel assembly	$\pm 0.1 \text{ mm}$	Positioning of the cavity w.r.t. beam axis $\pm 0.5 \text{ mm}$
	Supporting system assembly	$\pm 0.2 \text{ mm}$	
	Vacuum vessel construction	$\pm 0.2 \text{ mm}$	
Transport and handling ($\pm 0.5 \text{ g}$ any direction)	N.A.	$\pm 0.1 \text{ mm}$	Stability of the cavity w.r.t. beam axis $\pm 0.3 \text{ mm}$
Testing/operation	Vacuum pumping	$\pm 0.2 \text{ mm}$	
	Cool-down		
	RF tests		
	Warm-up		
	Thermal cycles		

Construction precision

Long-term stability



Heat Loads (per $\beta=1$ cavity)

Operating condition	Value (nominal/"ultimate")
cryo duty cycle	4.11%/8.22%
quality factor	$10/5 \times 10^9$
accelerating field	25 MV/m

Source of Heat Load	Heat Load @ 2K (nominal/"ultimate")
dynamic heat load per cavity	5.1/20.4 W
static losses	<1 W (tbc)
power coupler loss at 2 K	<0.2/<0.2 W
HOM loss in cavity at 2 K	<1/<3 W
HOM coupler loss at 2 K (per coupl.)	<0.2/<0.2 W
beam loss	1 W
Total @ 2 K	8.5/25.8 W

Cryogenic scheme (latest version)

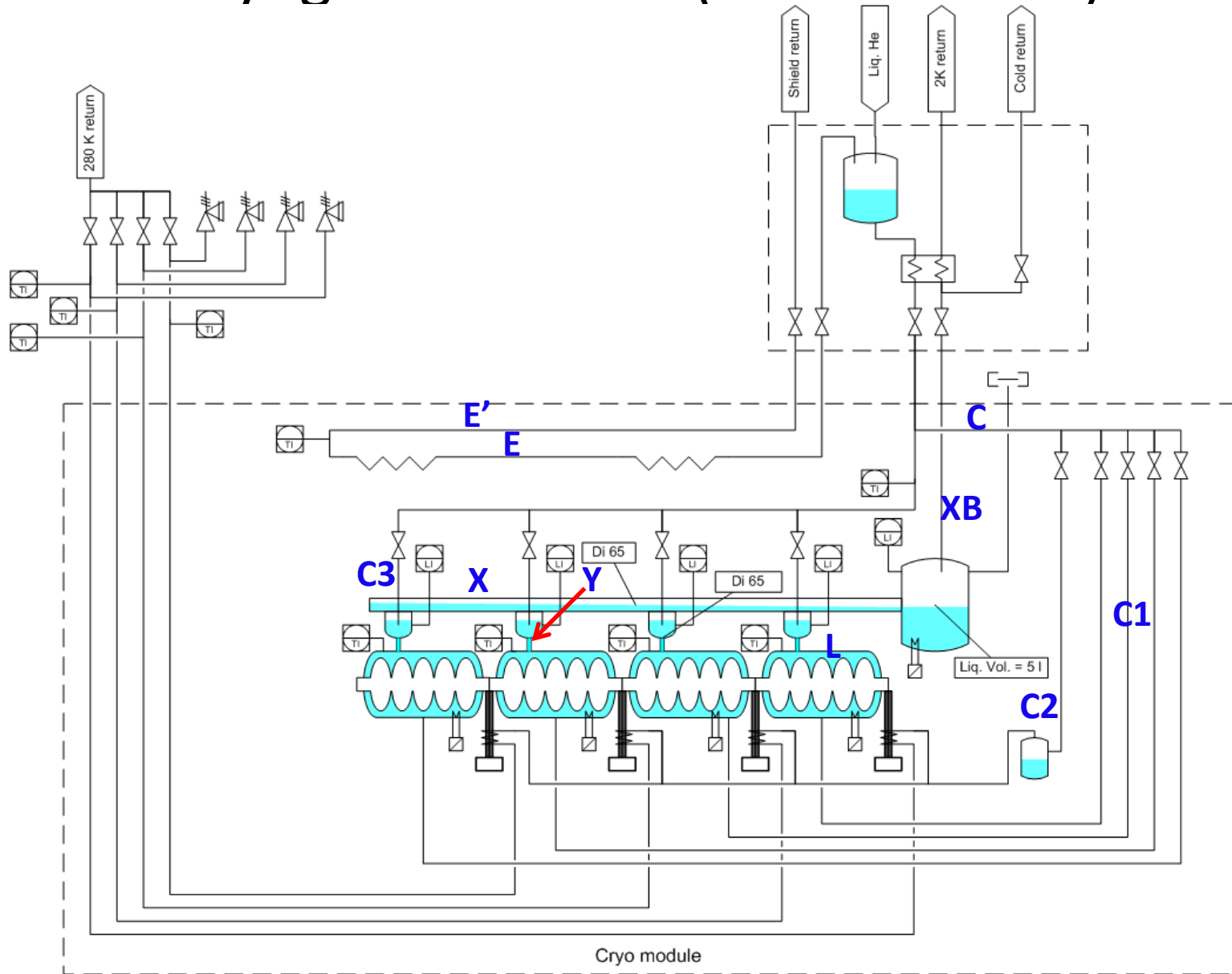



Pipe sizes and T, p operating conditions

Line	Description	Pipe Size (ID,mm)	Normal operating pressure [MPa]	Normal operating temperature [T]	Cool-down/warm-up pressure [MPa]	Cool-down/warm-up temperature [K]	T range [K]	Maximum operating pressure [MPa]	Design pressure [MPa]	Test pressure [MPa]	Comment
L	Cavity helium enclosure	400	0.0031	2	0.13 @ 293K 0.2 @ 2K	293-2	2-293	0.15 @ 293K 0.2 @ 2K	TBD	TBD	
X	Bi-phase pipe	100	0.0031	2	0.13 @ 293K 0.2 @ 2K	293-2	2-293	0.15 @ 293K 0.2 @ 2K	TBD	TBD	
Y	Cavity top connection	80	0.0031	2	0.13 @ 293K 0.2 @ 2K	293-2	2-293	0.15 @ 293K 0.2 @ 2K	TBD	TBD	
XB	Pumping line	100	0.0031	2	0.13 @ 293K 0.2 @ 2K	293-2	2-293	0.15 @ 293K 0.2 @ 2K	TBD	TBD	
E	Thermal shield supply	40 (TBD)	2.0	50-75 (20-40 on test stand?)	2.0	293-50	50-293	2.0	2.0		Heat intercept
E'	Thermal shield return	15 (TBD)	2.0	50-75 (20-40 on test stand?)	2.0	293-50	50-293				Return only
W	Cryostat vacuum vessel	1000 (TBD)	vacuum	293	vacuum	293	237-293	O.P. 0.1	I.P. 0.15	N.A.	
C1	Cavity filling	4	0.1	4.5	0.1	293-4.5	4.5-293				Liquid supply
C2	Coupler cooling	15 (TBD)	0.1	4.5-293	0.1	293-4.5	4.5-293				Gaseous supply
C3	Cavity top supply	6	0.1	2	0.1	293-4.5	2-293				Liquid supply

Short cryomodule: layout sketch

