

The Silicon Photomultiplier-based Camera for the Cherenkov Telescope Array Small-Sized Telescopes

Jon Lapington – University of Leicester

For the CTA SST Project

This work was conducted in the context of the CTA SST Project

11th International Workshop on Ring Imaging Cherenkov Detectors

Outline

- Cherenkov Telescope Array (CTA)
- Small-Sized Telescope (SST)
- Compact High-Energy Camera (CHEC)
- SST Camera Project
- Summary

Cherenkov Telescope Array (CTA)

CTA – The next big step...

- World's first VHE gamma-ray observatory
- Explores top 4-5 decades in energy - 20 GeV to 300 TeV
- Factor of 10 improvement in sensitivity compared to current telescopes
- Full sky coverage
- Large community of users



The Cherenkov Telescope Array

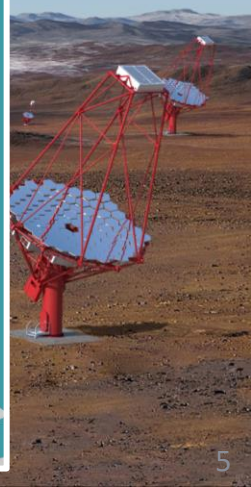
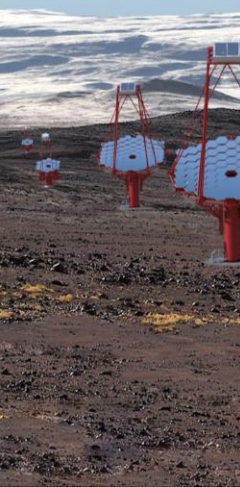

The Cherenkov Telescope Array

CTA South, Paranal – Baseline configuration



70 Small Sized Telescopes (SST)

- 4 m diameter reflector
- > 8° FoV
- ~4 km²

25 Medium Sized Telescopes (MST)

- 12 m diameter reflector
- > 7° FoV
- ~1 km²

4 Large Sized Telescopes (LST)

- 23 m diameter reflector
- >4.5° FoV
- ~0.1 km²

Initial Alpha configuration

- CTAO Northern Array: 4 Large-Sized Telescopes and 9 Medium-Sized Telescopes (area covered by the array of telescopes: ~0.25 km²)
- CTAO Southern Array: 14 Medium-Sized Telescopes and 37 Small-Sized Telescopes (area covered by the array of telescopes: ~3 km²)

CTA Science: Full-sky Coverage

North+South

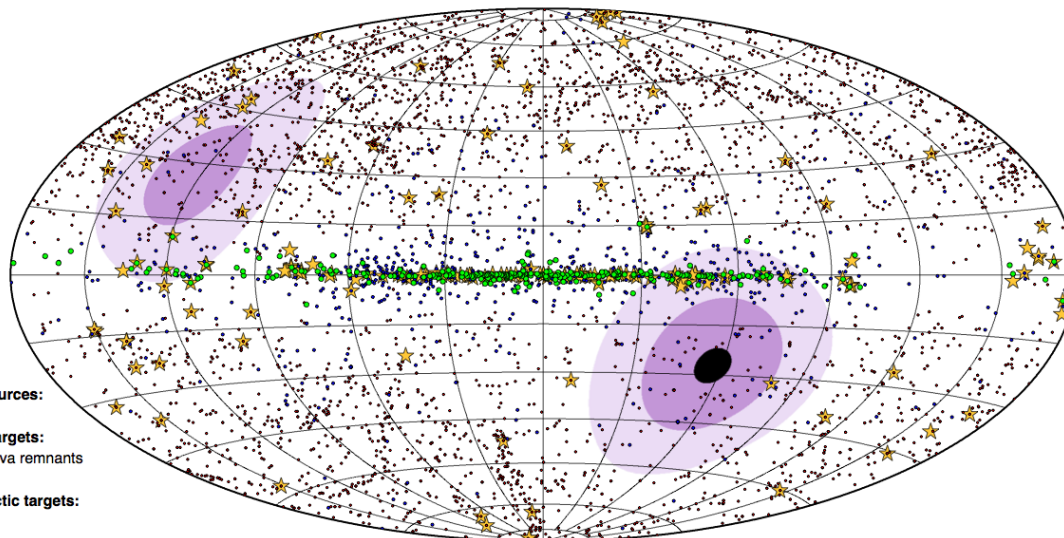

>60° zenith
45°-60°
30°-45°

- Known sources:
 - ★ TeVCat
- Galactic targets:
 - Supernova remnants
 - Pulsars
- Extragalactic targets:
 - Blazars

South

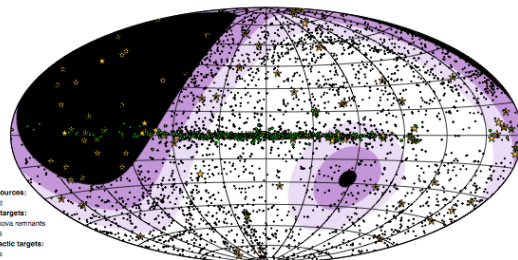

- Known sources:
 - ★ TeVCat
- Galactic targets:
 - Supernova remnants
 - Pulsars
- Extragalactic targets:
 - Blazars

North

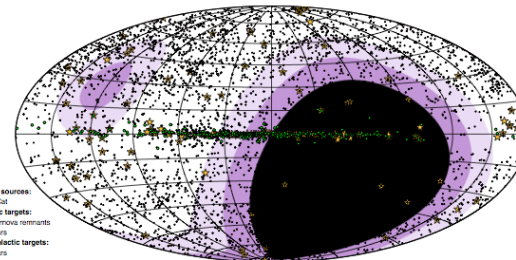

- Known sources:
 - ★ TeVCat
- Galactic targets:
 - Supernova remnants
 - Pulsars
- Extragalactic targets:
 - Blazars

CTA Science: Improved Sensitivity

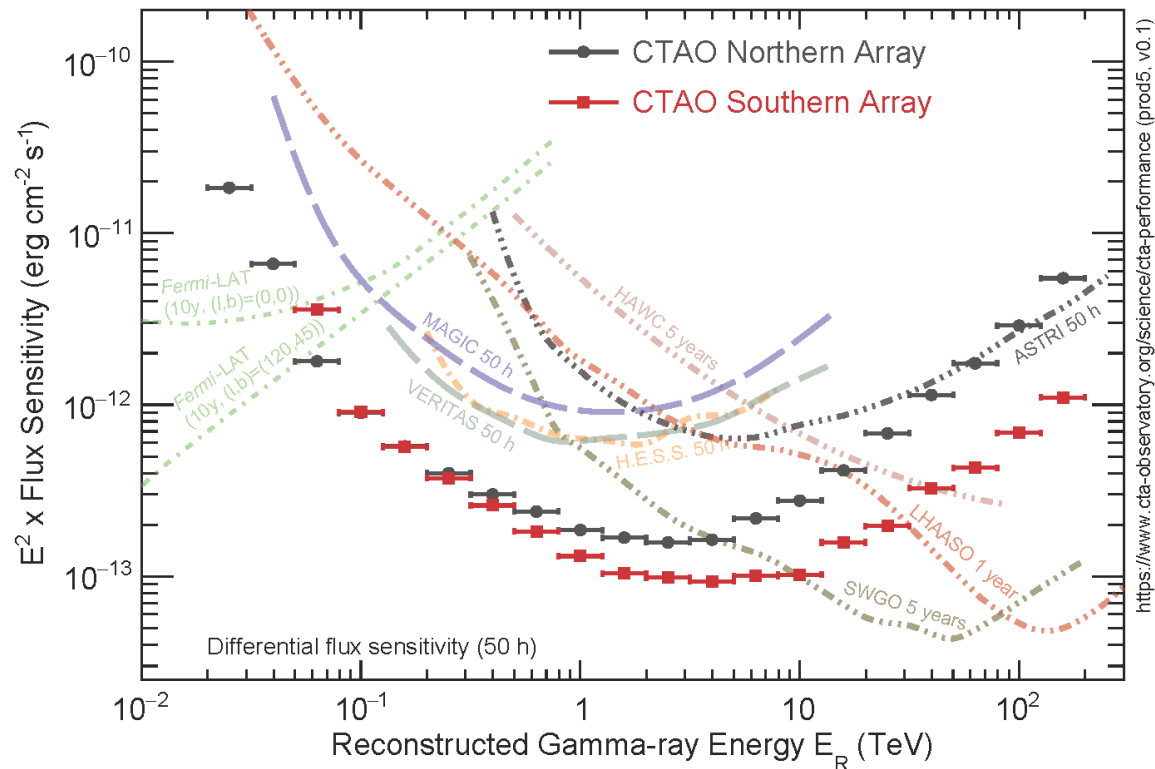

CTA Science: Improved Sensitivity

LMC and Galactic Plane observations will provide many more detections

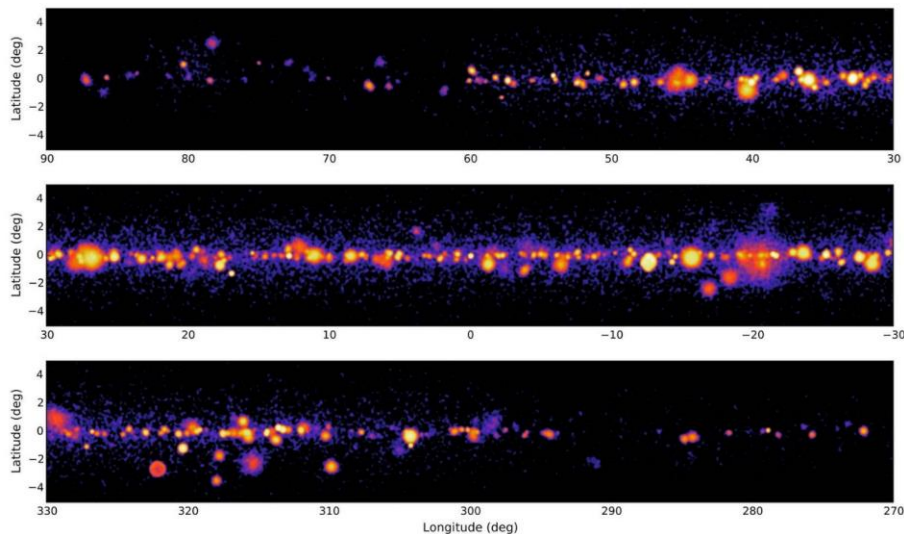
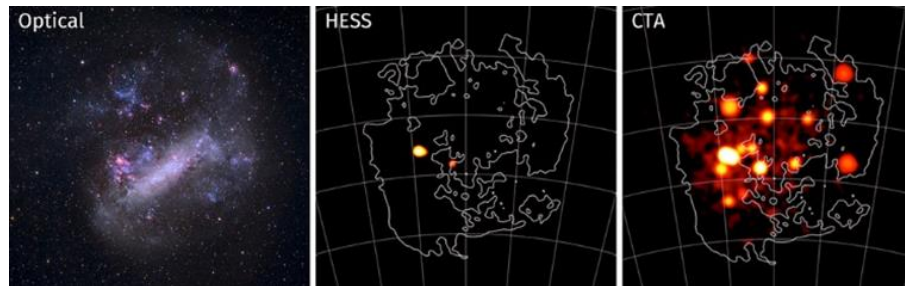

Expect an increase of a factor of ~ 10 in the source catalogue.

CTA Science: Improved Angular Resolution

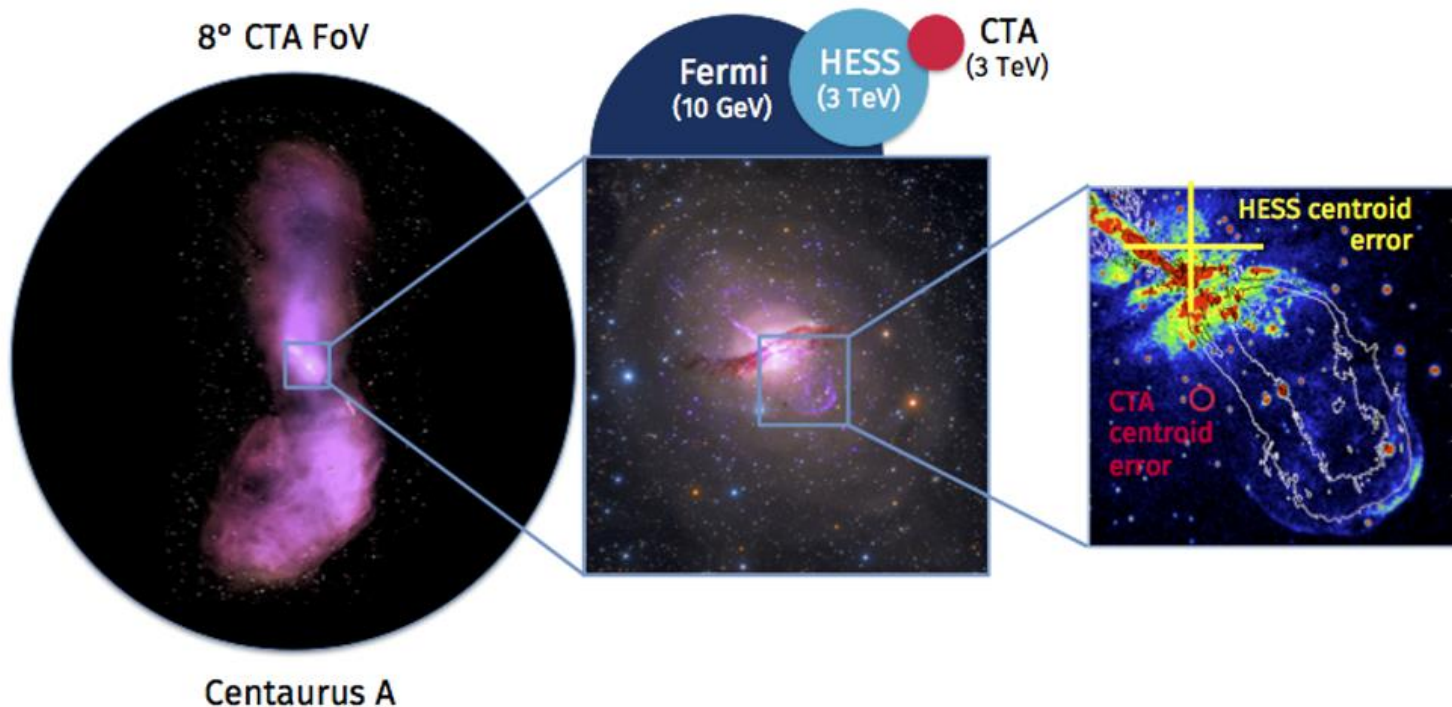

The best angular resolution of any instrument above 100 keV

Small-Sized Telescope (SST)

Three SST Designs Proposed

- Dual mirror (SST-2M) design allows use of a compact camera
 - Short focal length → reduced plate scale → **small camera and pixels**
 - Candidate sensors: MAPMTs, SiPMs
- Technical challenges
 - Curved focal plane ($R_c = 1.0$ m)
 - High density readout electronics required
 - Low cost

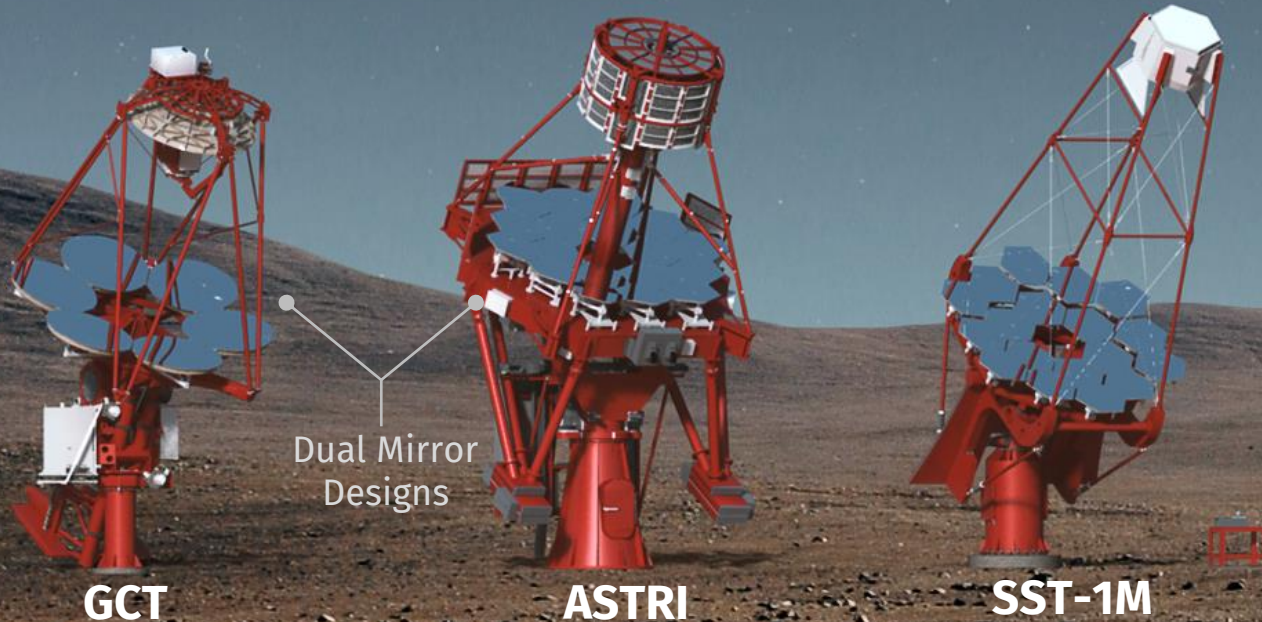

Three Prototype SSTs Developed

- Prototypes for all SSTs (telescopes and cameras) exist
 - The dual-mirror telescope prototypes provided an excellent test-bed for CHEC

Meudon, France



GCT

Serra La Nave, Italy



ASTRI

Krakow, Poland



SST-1M



CTA Small-Sized Telescope

CTA-SST dual-mirror design

- CTA-SST dual-mirror (SST-2M) telescopes
 - Uses Schwarzschild-Couder optics, as first proposed for IACTs by Vassiliev
 - SST-2M telescopes designed to be compatible with same camera
 - Small plate scale enables use of smaller, lower cost camera – CHEC
- SST design drivers:
 - High performance at low cost
 - Ease of production and maintenance

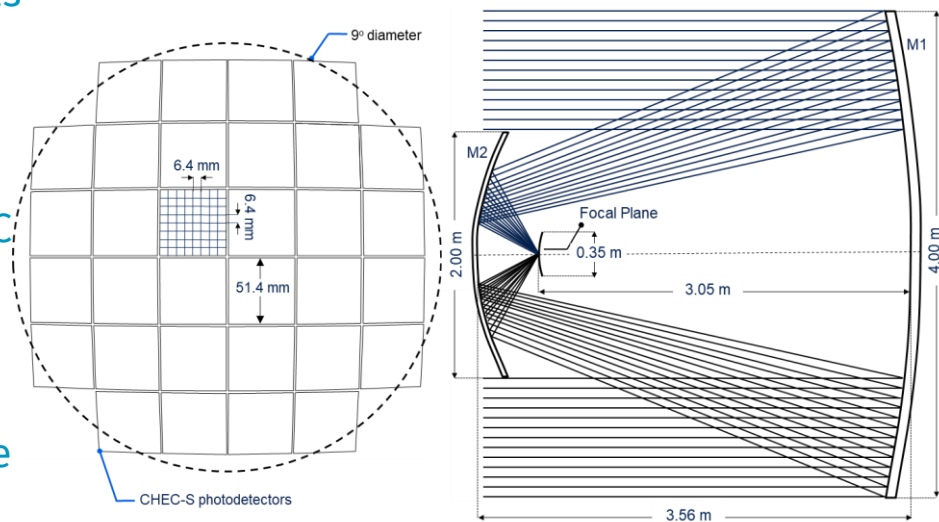

SST Camera

Requirements



- Small-Sized telescopes
 - Large area coverage essential to detect rare high energy gamma-rays
 - Good event quality – multiple images of air shower increases measurement precision
 - many units → low unit cost
 - High telescope-multiplicity events
 - highest energy resolution events of CTA at around 10 TeV
- SST Camera Design Implications
 - Large impact distance measurements
 - wide field of view, large time gradients
 - Wide field of view without compromise on image resolution
 - many pixels → low-cost individual pixels
 - Large time gradients
 - digitization within wide time window – flexibility for optimal offline extraction of time and intensity information

ASTRI and GCT

Competing SST-2M designs

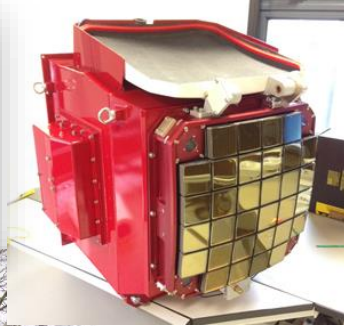
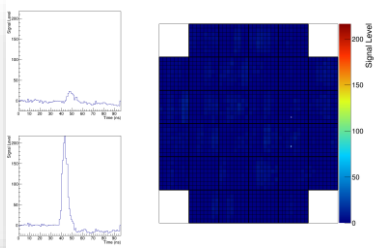

GCT
GATE telescope
CHEC-M camera
Paris-Meudon



November 2015 – first ever Cherenkov light for a CTA prototype



ASTRI telescope
and camera
Serra La Nave
Observatory
Sicily

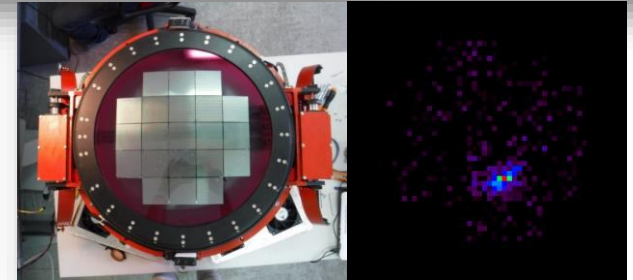

CHEC-M

On-Telescope Tests in Meudon

- Cherenkov Images

- Successful self-triggering on Cherenkov events (cosmic rays – no γ -rays)
- First light for any CTA prototype

Event 5
Example of a single event
recorded on-sky

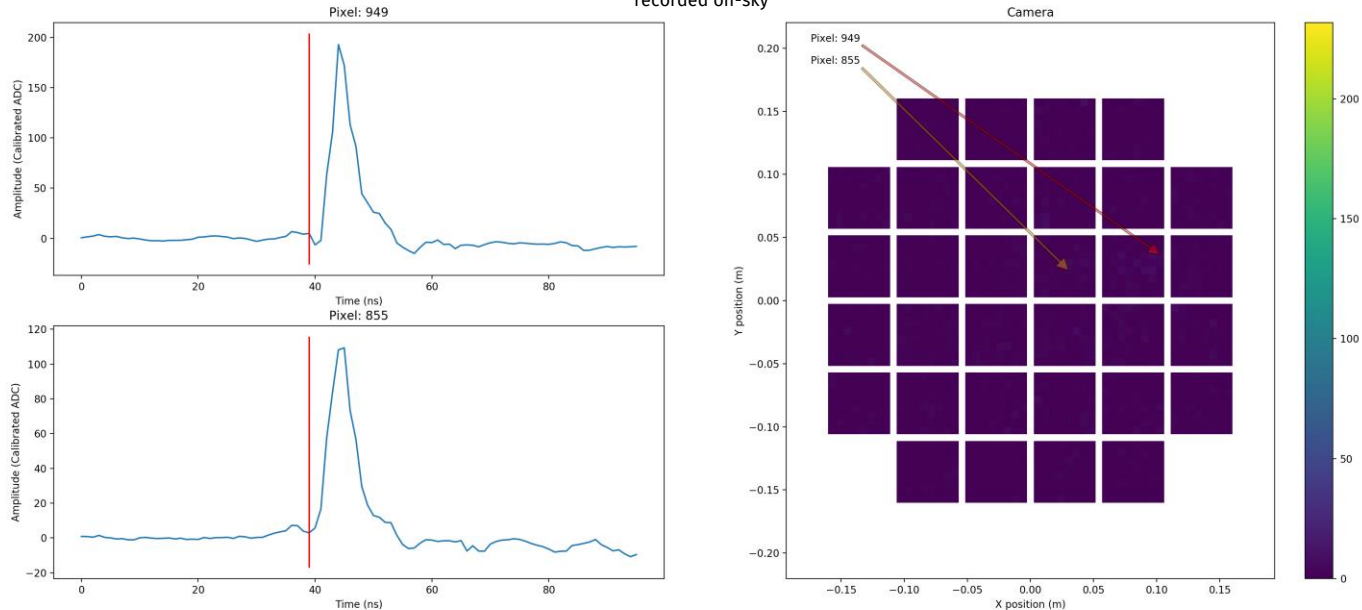

Compact High-Energy Prototype (CHEC)

Prototyping CHEC

Overview

- CHEC-M & CHEC-S
 - Same fundamental architecture
 - Different photosensor technologies
- Tested in the lab and on-telescope
 - CHEC-M on GATE (GCT)
 - CHEC-S on ASTRI

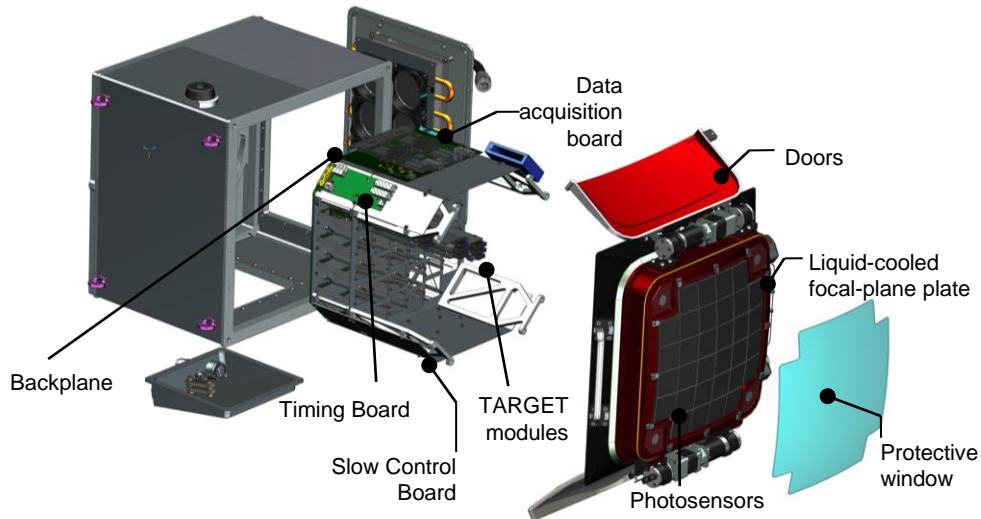

CHEC-M on GCT: first light for any CTA prototype

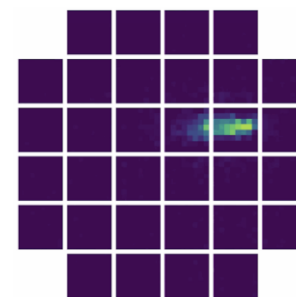

Prototyping CHEC

Evolution

- CHEC-M
 - MAPMTs
 - TARGET 5
 - 1 Gbps DACQ boards
 - Wash U. Backplane

→ Proof of principle of many aspects (e.g. triggering and readout), limited by ASIC performance and MAPM gain spread
- CHEC-S
 - SiPMs
 - Liquid cooling
 - TARGET C and TARGET T5TEA
 - In-Project Backplane
 - 10 Gbps XDACQ
 - Slow signal chain for pointing

→ Most CTA requirements met, performance limited by SiPMs and thermal control

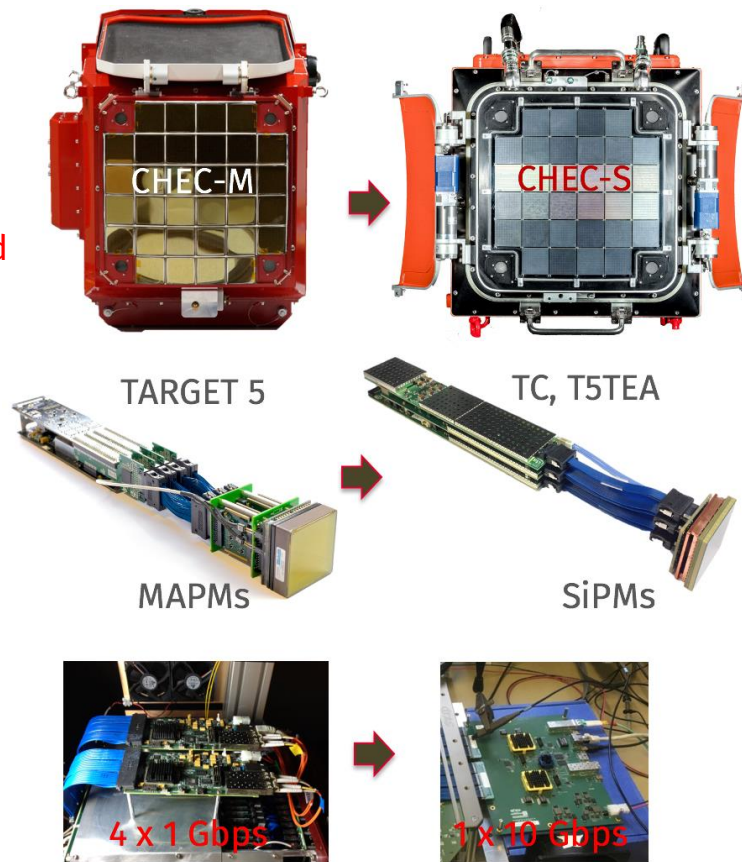

Prototyping CHEC

CHEC-S

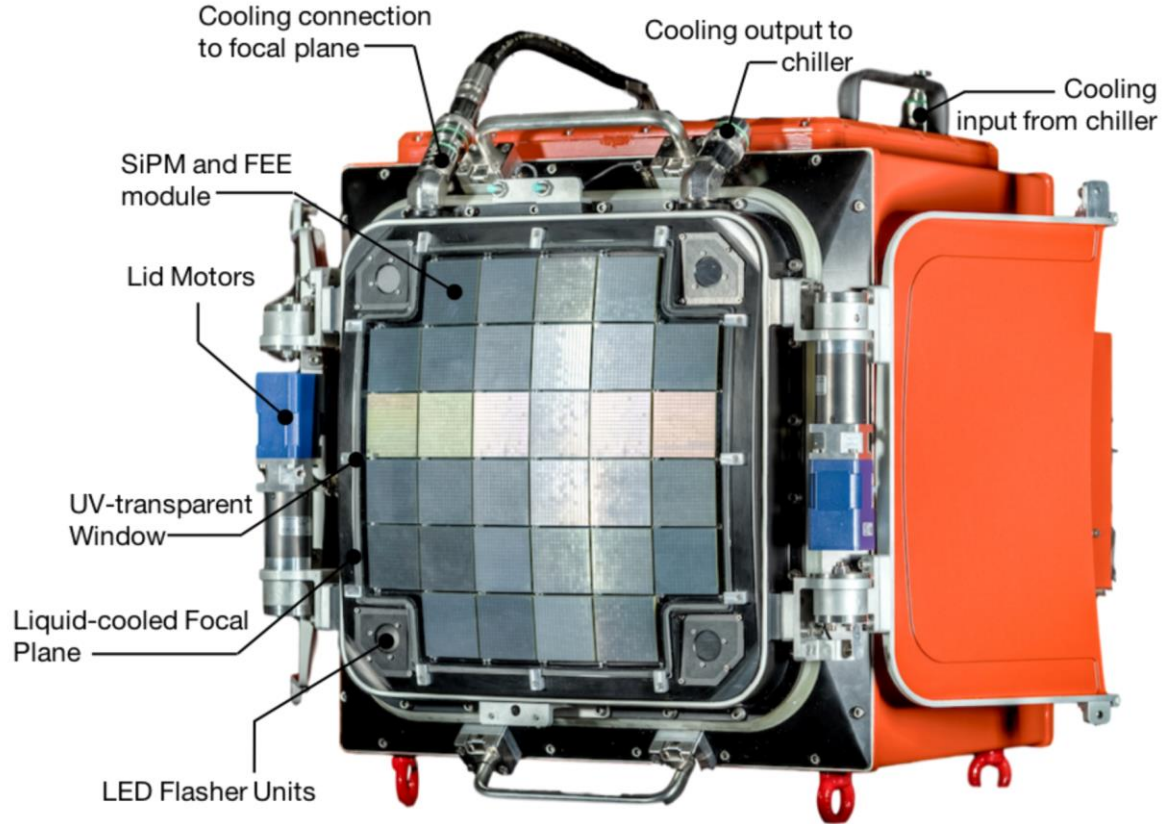

Prototyping CHEC

CHEC-S

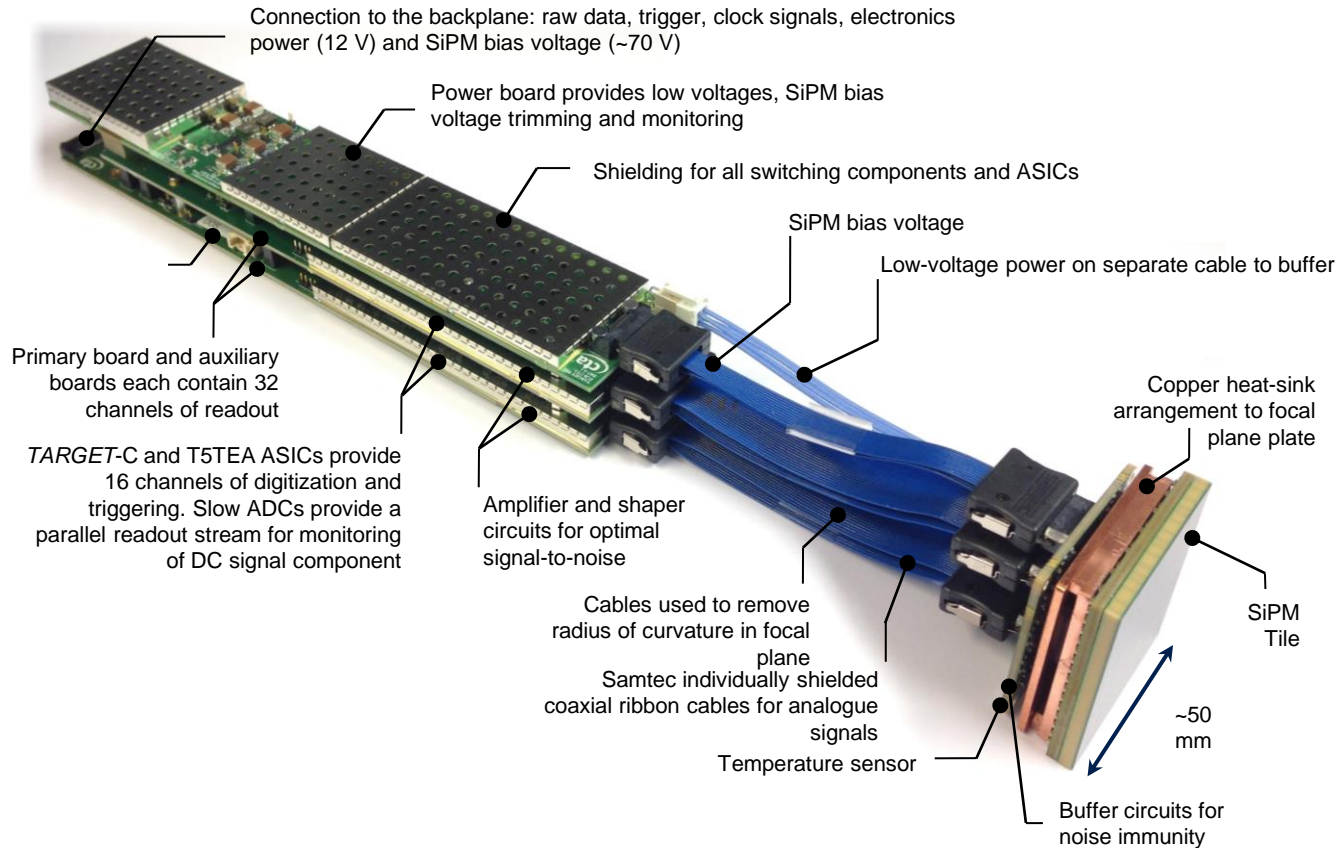

Prototyping CHEC

Camera Architecture

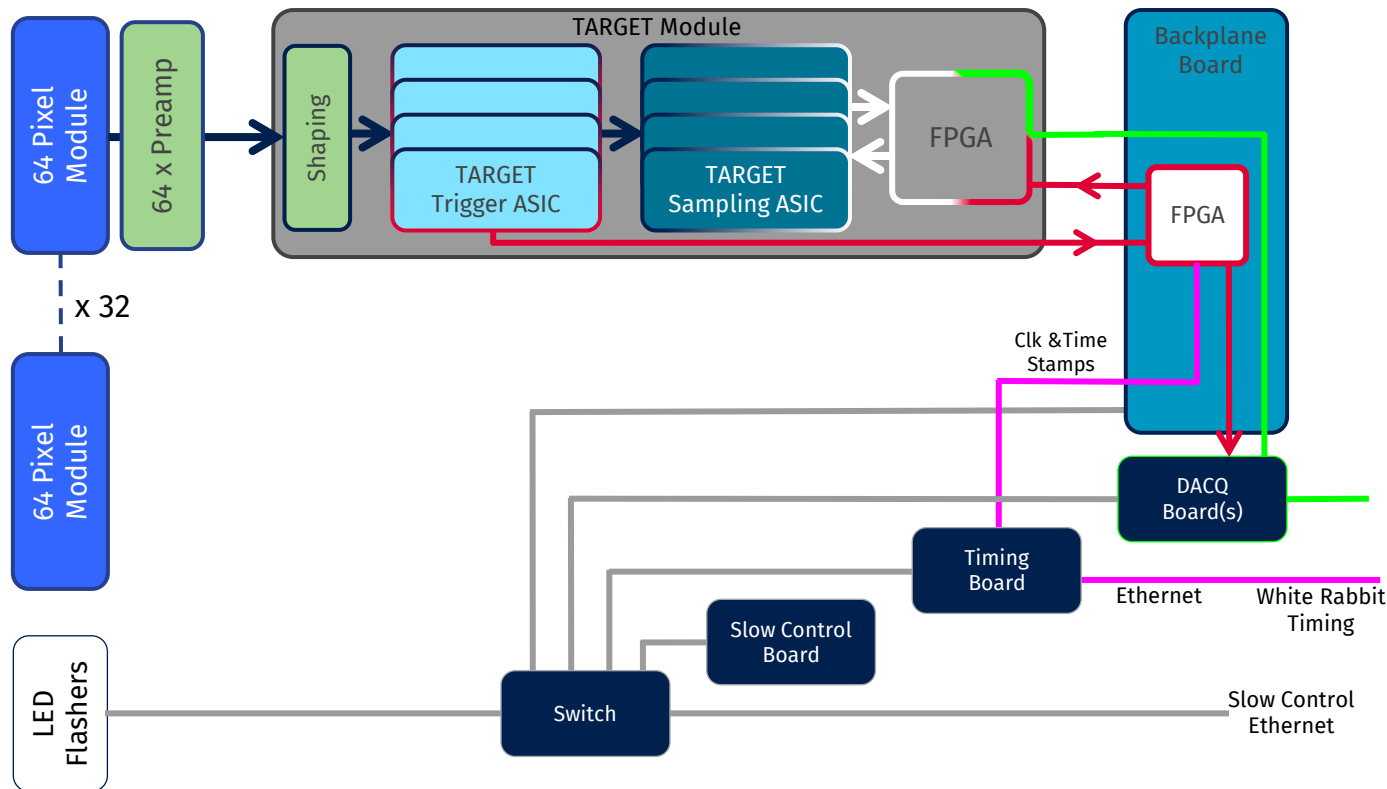

CHEC Field Trials

An obvious place to put a telescope!



It worked!

Sicily, Southern slope of Mt. Etna at
Serra La Nave

Hosted by INAF-Catania

1750 m asl

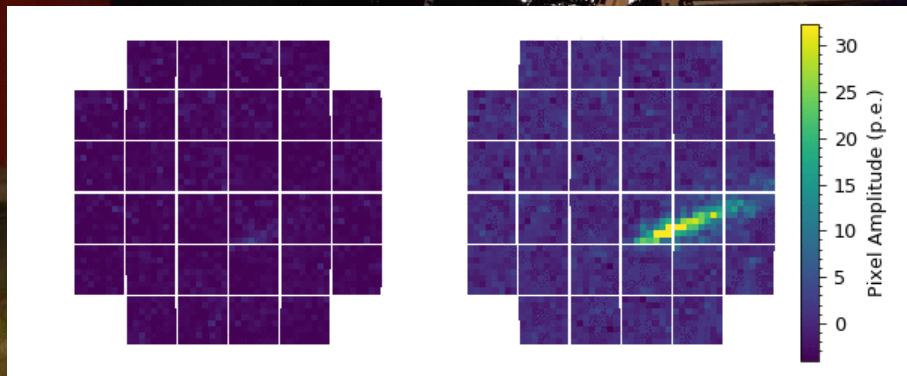
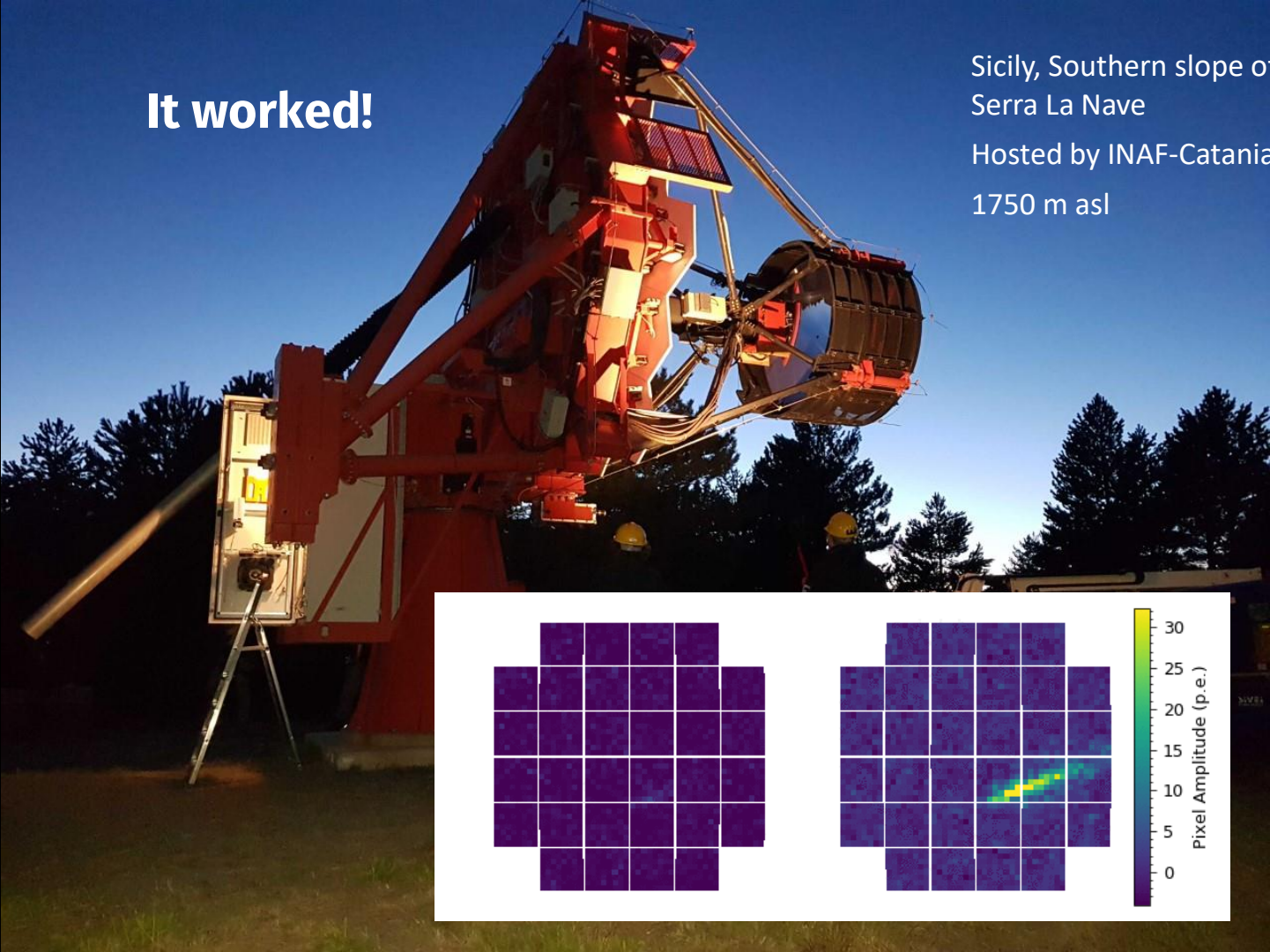

ASTRI-CHEC Campaign

Field trials - 2019

- CHEC-S installed on ASTRI in 2019
 - Interfaces prepared before arrival and verified
 - First light ~48 hours after arrival onsite
 - Images in focus without additional camera alignment
 - On-sky data a good match to MC expectations
 - Continuous calibration performed in parallel to observations
 - Astrometric verification via slow signal
 - Photosensor calibration via interleaved LED flashes
 - On-telescope operations fully exercised

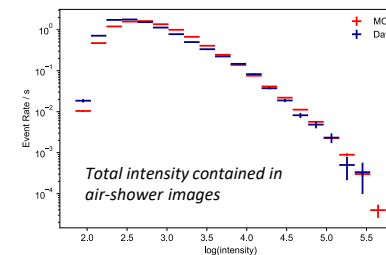
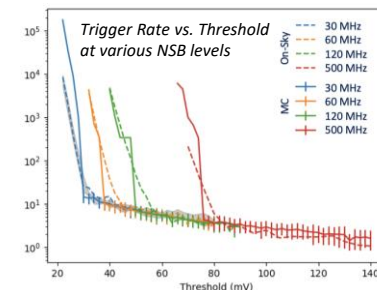
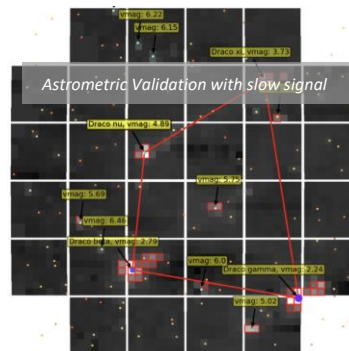
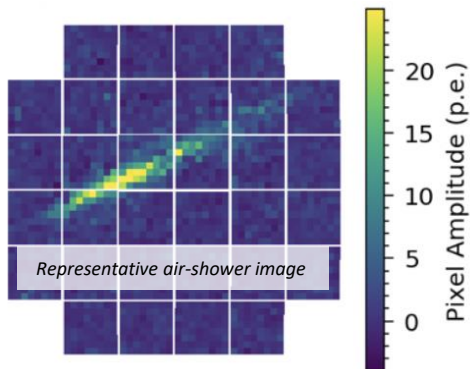

ASTRI-CHEC Campaign

Field trials - 2019

- Observation strategy during CHEC-on-ASTRI campaign: Wobble Mode
 - Pointing direction is offset from the source by 1 degree
 - Observations alternate between offsets on different sides of the source
- Priority of campaign: Test on-telescope operation of camera and compatibility with ASTRI structure - **SUCCESS**
- Gamma-ray source observation: Sensitivity limited by mirror reflectivity

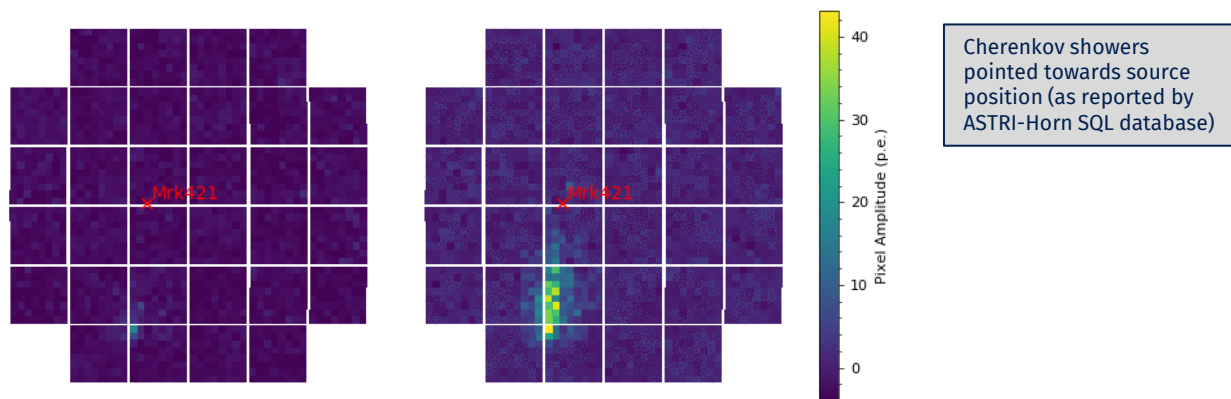

2019-05-02 20:49:33.133597552

CHEC-S on ASTRI

Field trials - 2019

- Slow signal – Predicted pointing accuracy
 - Utilise timing information as star crosses pixel boundary
 - Simulations: 4-5 arcseconds
 - Requires ~10 stars in FoV
 - Up to 30 stars expected in a typical FoV (Vmag < 9)
- Can be used for
 - NSB level during observations
 - Disabling pixels with stars present
 - Telescope pointing
 - PSF across FoV

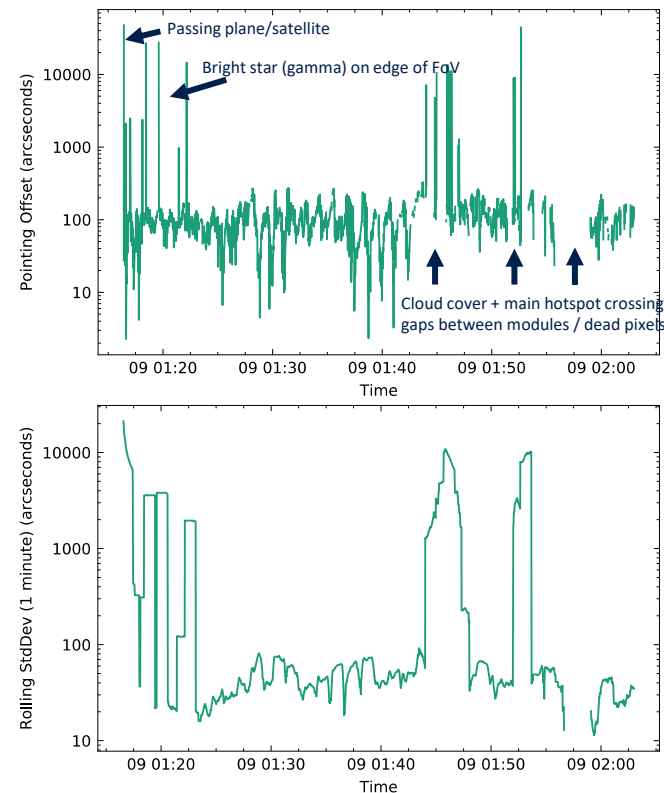
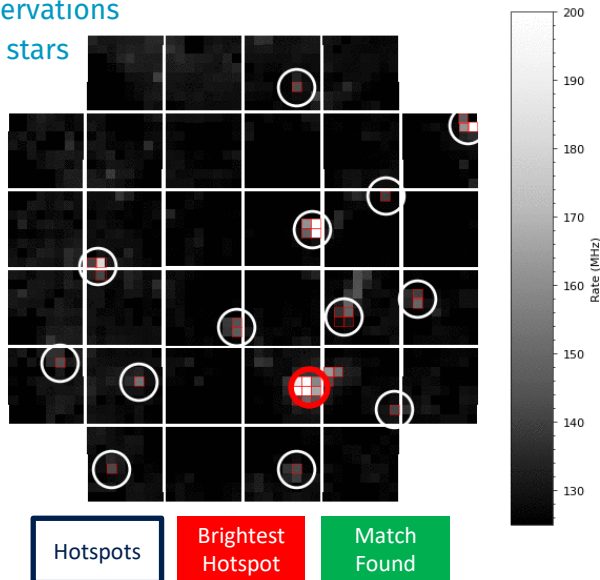

SST Camera Project

SST Camera Selection

- Following 2019 CTAO Harmonization review
 - CHEC selected as baseline SST Camera
 - ASTRI selected as baseline telescope
- SST Camera Key Features
 - Fine pixellation, $\sim 9^\circ$ FoV
 - SiPMs with Target ASIC readout
 - 5x lower cost than MST/LST per pixel
 - Higher detector efficiency
 - Efficient trigger scheme
 - Full waveform readout
- Now focused on an iteration to ensure
 - Ease of production
 - High quality
 - Ease of installation
 - Low maintenance needs

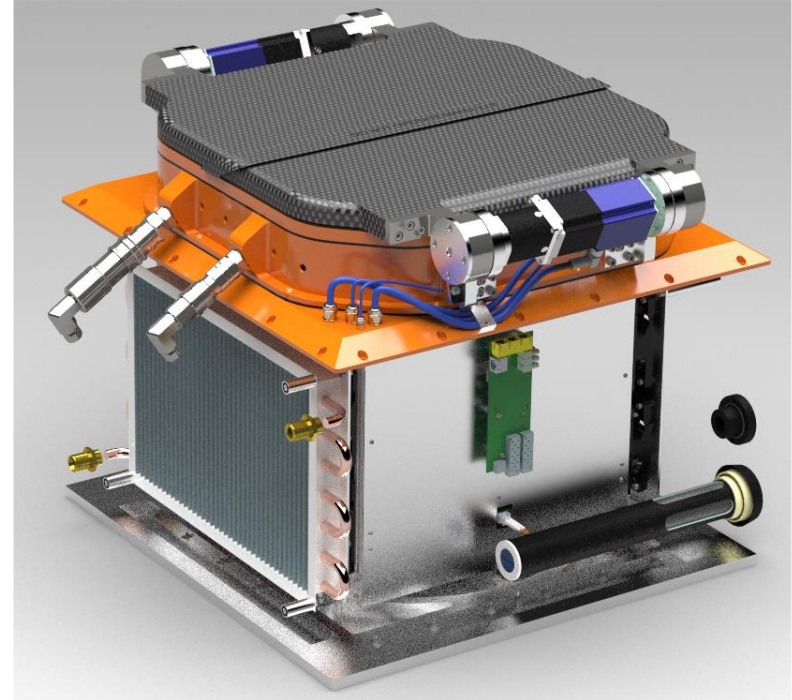

SST Camera

Design Finalization

Many lessons learnt from CHEC prototypes

- Assembly concept
 - Involves removing SiPMs to access Target Modules
 - Risk of SiPM damage
 - Involves inserting Target Modules through focal plane
 - Risk of TM damage

New camera assembly scheme – SOLVED BOTH
- SiPMs
 - Optical Cross Talk (40%)
 - Limits trigger performance and charge reconstruction
 - Latest LVR3 SiPM devices utilized – SOLVED
 - Control (Bias voltage resolution)
 - Limits trigger uniformity
 - Per pixel bias redesign - SOLVED
- Cooling capacity
 - Adequate for SiPMs (FPP worked well)
 - But large gradient across TMs ($> 20\text{ }^{\circ}\text{C}$)
 - Limits charge reconstruction (ASIC temperature dependence)
 - Cooling system upgrade – SOLVED
- LED Flasher concept
 - Relies on reflection from M2
 - Hard to calibrate in the lab

New Flasher circuit design and placement – SOLVED BOTH

TM
insertion

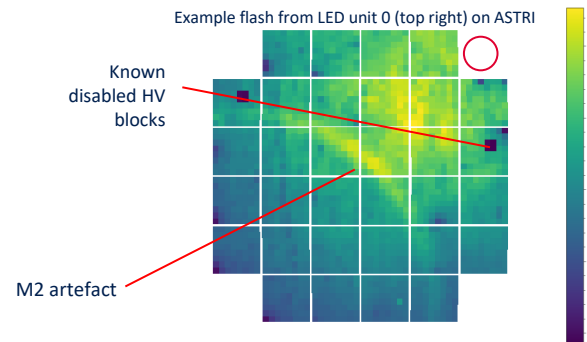
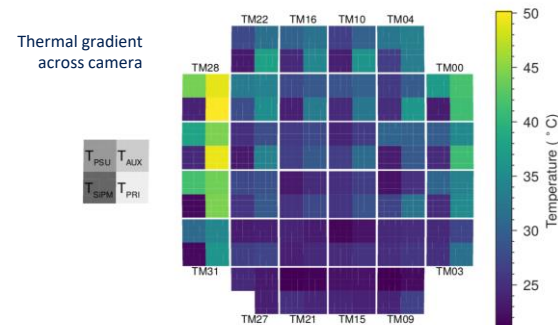

SST Camera

Design Changes

CHEC-S Prototype

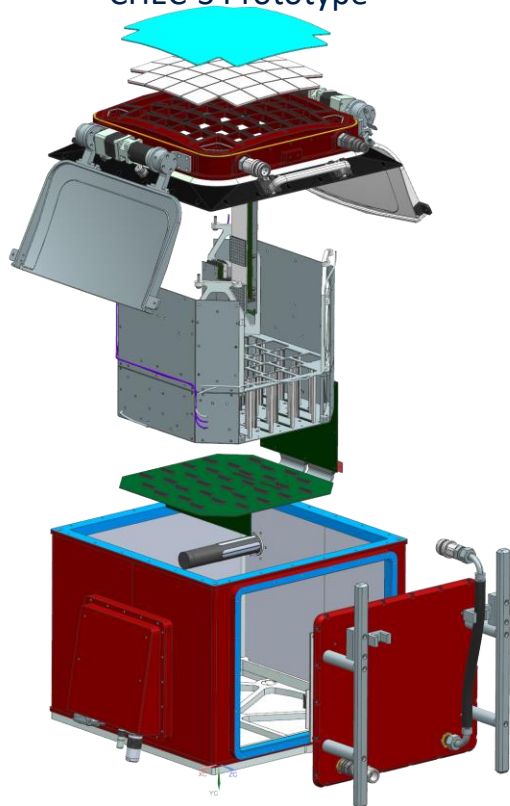

SST Camera

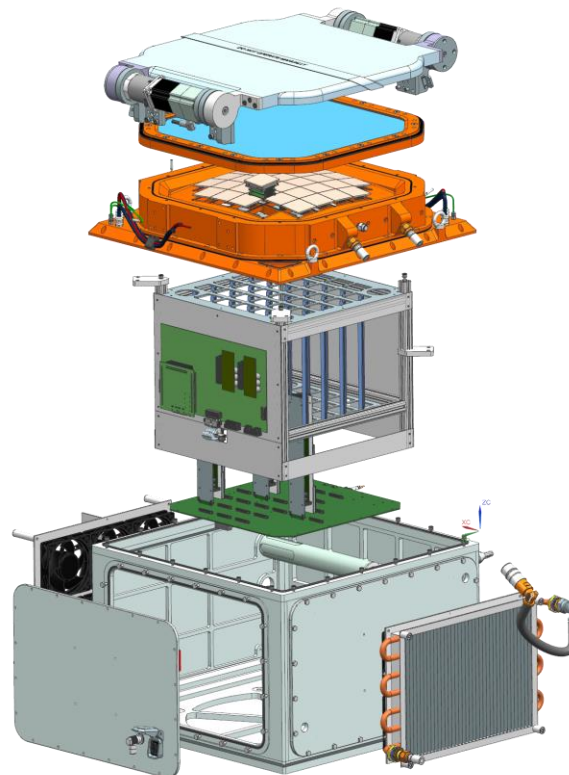

SST Camera Design

- Changes w.r.t. CHEC-S
 - Flat window
 - Updated SiPMs (+ matching changes to preamps & bias)
 - Small iteration to TARGET modules
 - Revised Backplane to include CHEC-S readout board (XDACQ)
 - Improved cooling and airflow

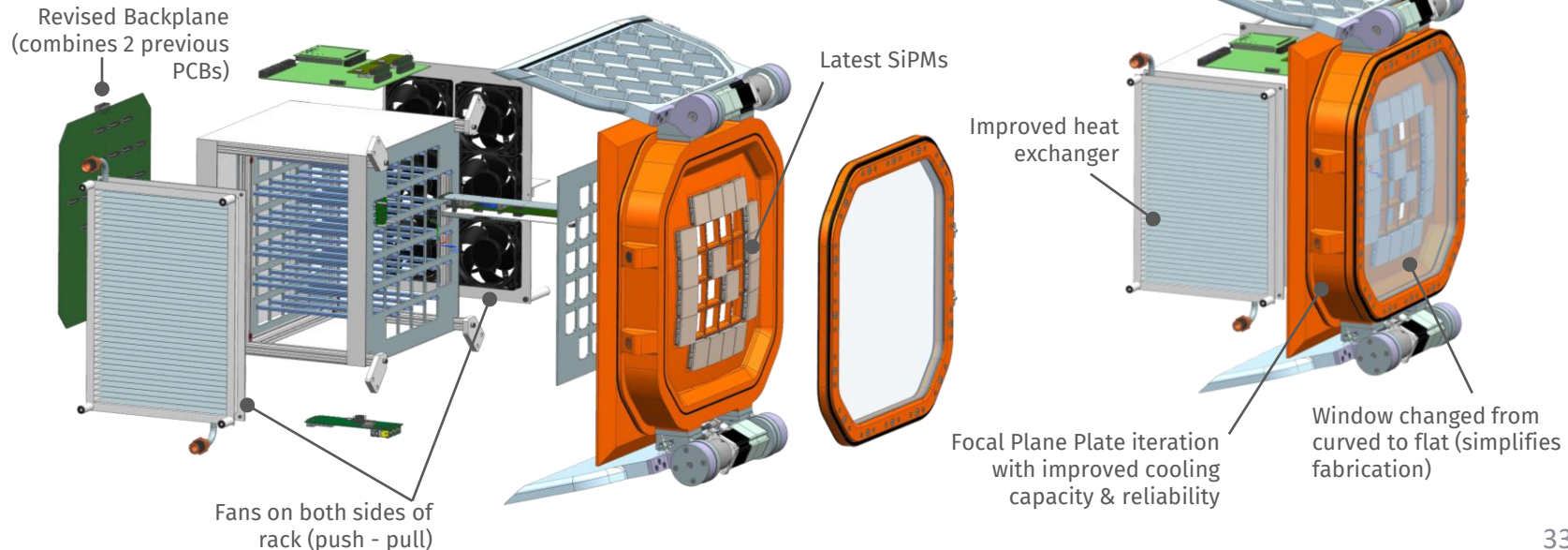
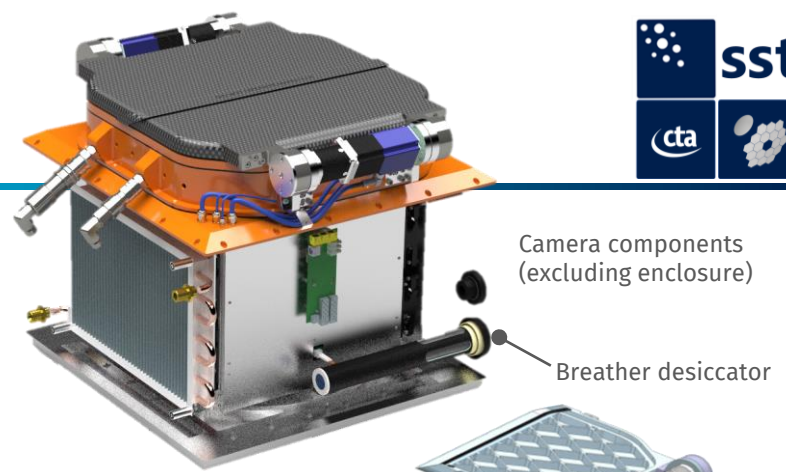

SST Camera Technical Status

Detailed design of many elements (prelim) complete, some examples shown here

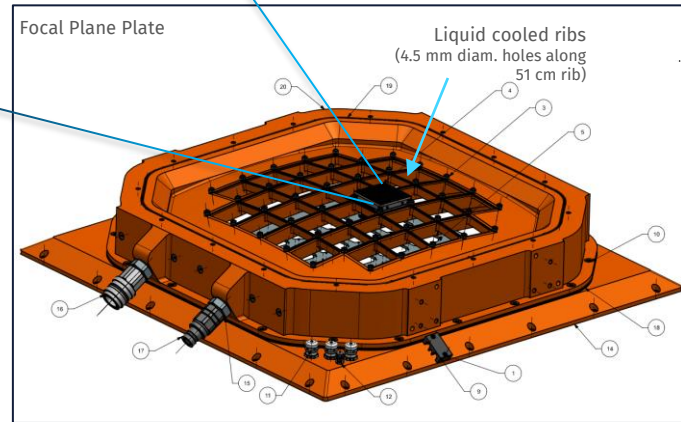
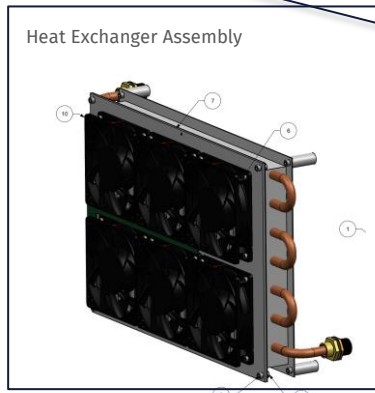
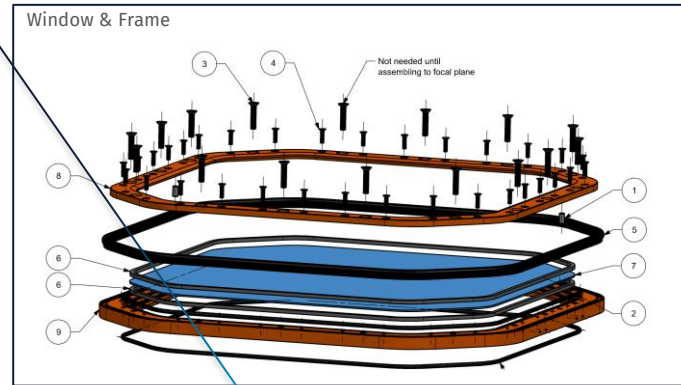
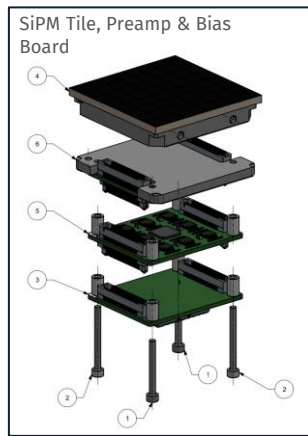
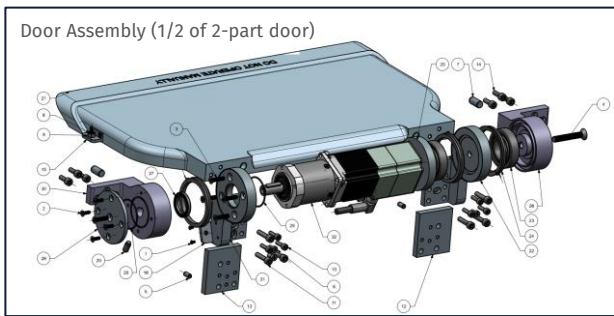

SST Camera Technical Status

A few examples of other recent technical developments

- Mechanical Tests
 - Liquid-cooled focal plane preliminary (welding + leak) tests complete
- Window
 - Production of 3 windows with varying thicknesses and coatings complete
 - Transmission measurements underway
 - Uniformity tests indicate ~1% RMS (@400 nm)
- SiPMs
 - Candidate tests complete and SiPMs chosen
 - Hamamatsu LVR3, 50 μm , 6 x 6 mm², uncoated
 - Assembled onto custom PCB (64-pixel tiles) by Hamamatsu
 - Optimum heat flow, appropriate connectors, T sensors
 - Full camera + spares ordered
- TARGET ASICs & Modules
 - Latest ASICs tested & confirmed
 - Full camera + spares ordered
 - TARGET Module design iteration in progress
- Backplane
 - First “quarter” BP (handles 8 TMs) due ~now

Focal plane plate test piece with welded insert

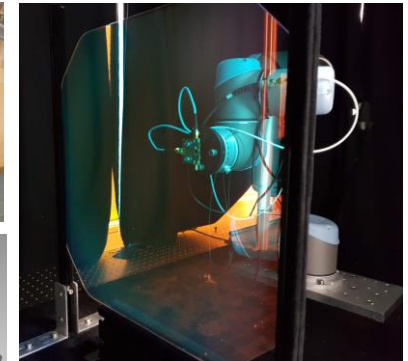
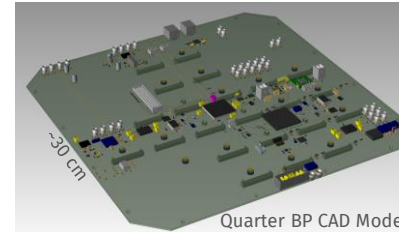

First full-scale window under test (430 x 430 mm, 2 mm thick)

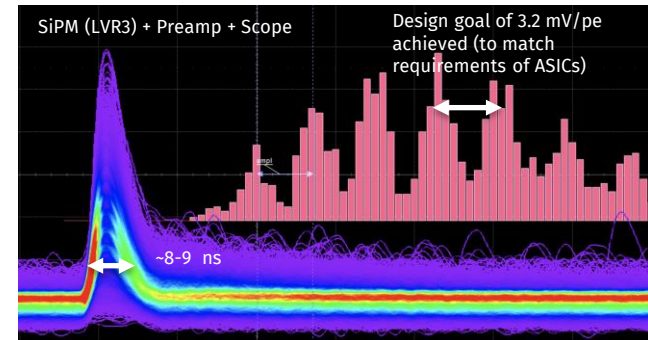

NB: Many detailed tests done on candidate SiPMs (report due soon).
Screen shot shown here for simplicity only.

Camera Series Production

Modular assembly

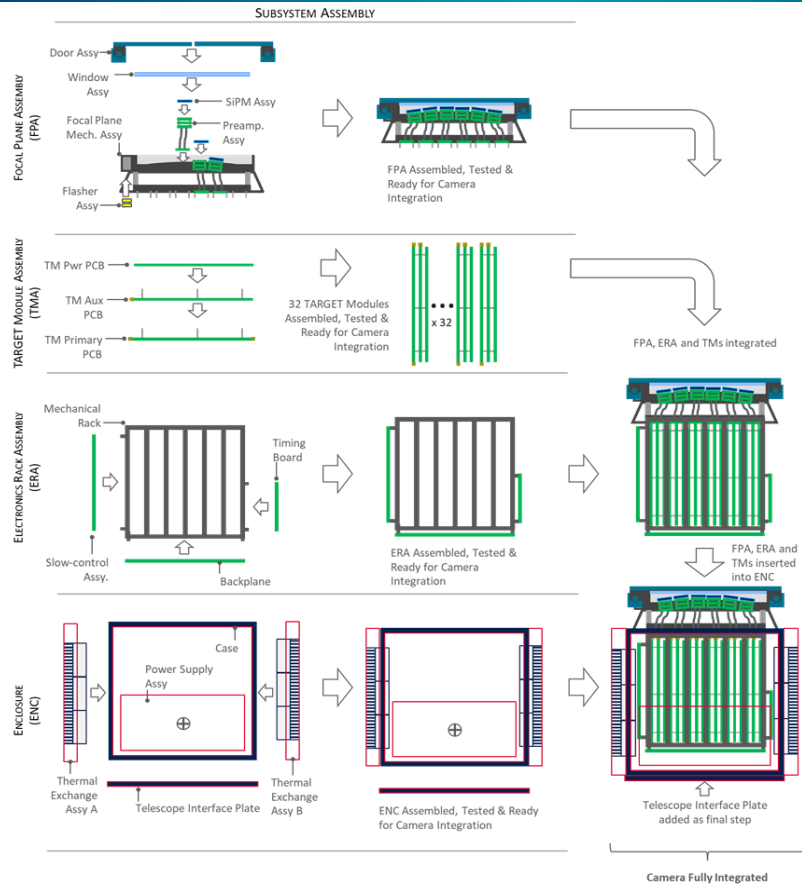

Camera Series Production

Timeline



- Series production can begin once:
 - Camera design is accepted by CTA Observatory (CDR mid-2023)
 - In-Kind Contribution (IKCs) agreements are signed
- Two camera production sites – Leicester, UK and MPIK Heidelberg
- Current schedule:
 - ERIC finalization – Early 2023 → agreement on IKCs
 - ERIC = European Research Infrastructure Consortium
 - SST Design Consolidation Phase – completion Q2 2024
 - First SSTs onsite – 2025
 - SST array (Alpha configuration) completion – 2027-2028

Summary

SST Camera - Summary

- Lessons learned from CHEC-S – completed
- Design iteration (for production) – well underway
 - Improved assembly concept – de-risk focal plane and TARGET module operations
 - Improved SiPMs: Hamamatsu LVR3 – higher PDE, lower OCT, bias control per pixel
 - Window design and performance improved
 - Backplane design modularized and de-risked
 - Cooling and temperature uniformity improved
 - Improved LED flasher concept
- Camera subsystem design largely completed and in manufacture
 - 1/4 camera (QCAM) build and test late-2022
 - Camera CDR mid-2023
 - Engineering Camera (ECAM) build and test mid-2023
 - ECAM Field testing late-2023
- Camera production phase
 - Begins 2024

We gratefully acknowledge financial support from the agencies and organizations listed here:
https://www.cta-observatory.org/consortium_acknowledgments/

Spare slides