

STATUS AND PROSPECTS OF THE ALFA ROMAN POT STATIONS

K.Hiller, DESY, Zeuthen, Germany

Abstract

ALFA is a sub-detector of the ATLAS experiment to measure the luminosity based on the rate of elastic proton scattering. It consists of fibre trackers in Roman Pots in a distance of 240m from the central ATLAS detector. The installation of all components in the LHC tunnel was finished in February 2011 and preparations for the physics data taking are going on.

LUMINOSITY MEASUREMENT

The main goal of the ALFA detector is a precise luminosity measurement [1]. It is based on the process of elastic proton-proton scattering and independent from the knowledge of beam currents. Due to the simplicity of the physical process which does not affect any other ATLAS detector the model-dependency of this method is very small. Based on these facts the luminosity measurement with ALFA is a valuable proof of the systematic errors of other luminosity measurements.

The elastic scattering is a traditional tool for luminosity measurement. This is related to the optical theorem which relates the total cross section σ_{tot} to the elastic scattering amplitude f_{el} in forward direction: $\sigma_{tot} = 4\pi \text{Im}[f_{el}(t=0)]$. The 4-momentum transfer squared t can be obtained from the scattering angle Θ and proton momentum p : $t = -(p\Theta)^2$. Using the luminosity definition as the proportional factor between total cross section and event rate $R_{tot} = L \sigma_{tot}$ the luminosity L can be obtained from the elastic rate R_{el} and the total rate R_{tot} :

$$\frac{1}{L} = \frac{1}{16\pi} \frac{\sigma_{tot}(1+\rho^2)}{dR_{el}/dt(t=0)}$$

with $\rho = \text{Re}[f_{el}(t=0)] / \text{Im}[f_{el}(t=0)]$. This method requires a good knowledge of the total event rate. Since ATLAS has a poor coverage at large values of the pseudo-rapidity η^1 uncertainties enter from the extrapolation. A way to avoid this uncertainty is to

¹⁾ $\eta = -\ln[\tan(\Theta/2)]$

express the total rate by the total cross section from an independent measurement e.g. the TOTEM experiment [2].

The main concept of the ALFA luminosity measurement is independent from any external input. It consist of the use of the well-known Coulomb cross section at smallest t as additional constraint. At smallest distances the scattering is dominated by the Coulomb force between the colliding protons. At larger distances the strong interaction mediated by the exchange of colour-neutral objects is the leading process. Ignoring smaller corrections like the proton form factor the elastic rate can be parametrized by only 4 parameters:

$$\frac{dN}{dt} \approx \pi \cdot L \left| \frac{-2\alpha}{|t|} + \frac{\sigma_{tot}}{4\pi} (i + \rho) \exp(-b|t|/2) \right|^2$$

The fit of the measured t -dependency gives the luminosity L as well as the other parameters σ_{tot} , ρ and the slope parameter b . Fig.1 shows the rate on dependence of t with the steep Coulomb behaviour and the flatter exponential part from the strong interaction.

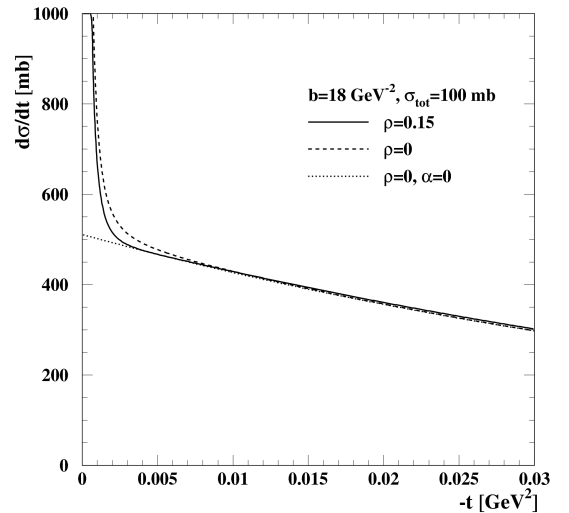

Fig.1: The t -dependency of the elastic proton scattering.

The difficulty in this kind of luminosity measurement is to access the Coulomb region at very small t on the order of a few 10^{-4} GeV². This requires special beam conditions to reduce the beam divergence at the interaction point well below the anticipated minimum t -value. The beam divergence is determined by the β function and the emittance ϵ at the interaction point: $\sqrt{\epsilon/\beta}$. The special optics scenario for ALFA combines high $\beta = 2625\text{m}$ with low $\epsilon = 1\mu\text{m}$. To detect elastic protons at smallest scattering angles requires to move the ALFA detectors very close to the circulating beam. The acceptance of ALFA detectors in a distance of 1.5 mm to the beam is about 50%. A phase advance of 90° in the vertical plane delivers a so-called parallel-to-point optics where protons emerging the interaction point under the same angle are focused to the same position in the ALFA detectors. Another condition for ALFA running is the zero crossing angle of colliding protons. This requires a rather limited number of colliding bunches. Together with the dilution of the beam due to the high β the specific luminosity will be on the order of 10^{-27} cm⁻²s⁻¹. Due to the special beam conditions the ALFA luminosity measurements will be performed only in short periods of a few days. At this low specific luminosity the consistency with other methods of luminosity measurements can be checked. The simulations carried out with the proposed optics and the detector performance described in [1] predict a luminosity error of 3% with similar contributions from the statistical and systematic sources.

DETECTORS PERFORMANCE

The tracking in the ALFA stations is based on multi-layer scintillating fibre detectors. Altogether 20 layers of staggered fibres with a squared cross section of 0.5×0.5 mm² measure the two coordinates perpendicular to the beam. In the upper and lower hemisphere the scattered protons can be traced by two identical detectors. The detectors, sketched in Fig.2, are housed in movable plunger vessels, so-called Roman Pots, which allow to bring them closer to the beam.

The fibres precisely glued on both sides of Titanium plates are inclined by $\pm 45^\circ$ in respect to the vertical axis. By a staggering of $50 \mu\text{m}$ the theoretical resolution is pushed to $14 \mu\text{m}$. The tracking detectors are covered by 2 scintillator tiles for triggering. For the physics analysis a distance measurement of the detectors in respect to the beam is needed. So-called overlap detectors measure the distance of the upper and lower fibre detectors and give an additional constraint to the positioning. Both overlap detectors are traversed by halo particles and the positions of tracks can be transformed into a distance. Similar to the main detectors the overlap detectors consist of 3 staggered

fibre layers. The anticipated precision of the distance measurement given by a large amount of halo particles is $10 \mu\text{m}$.

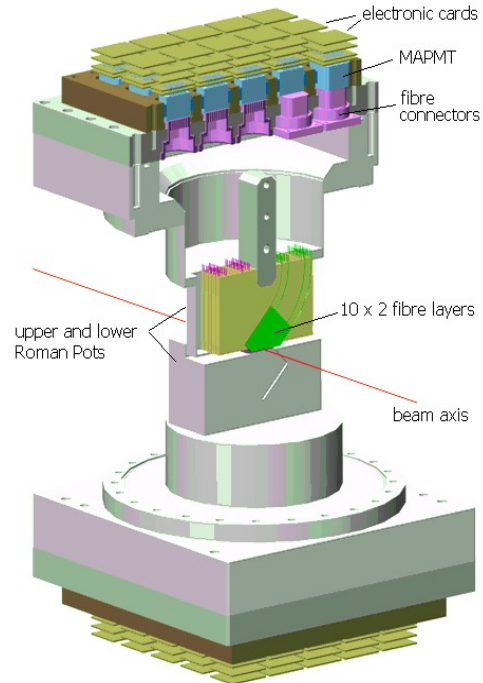

Fig.2 Upper and lower Roman Pot with the main fibre detectors and the routing to the MAPMTs. The overlap detectors are not shown.

The light signals generated by charged particles passing the scintillator material are guided to Multi-Anode Photo-Multipliers (MAPMT). The typical fibre signal gives about 4 photo-electrons on a Bi-alkali photo-cathode. Altogether 23 MAPMTs²⁾ with a grid of 8×8 readout pixels amplify the fibre signals. The readout of the trigger tiles is performed by clear fibre bundles glued to two tile edges. Both bundles result in a signal of about 40 photo-electrons from the trigger PMT³⁾ photo-cathode.

The front-end electronics is compressed in a compact package of boards directly sitting at the MAPMT back side. The active board contains a 64 channel MAROC chip which amplifies and discriminates all signal which are sent by flat Kapton cables to the motherboard.

In the year 2010 the final sets of all detectors, motherboards and Roman Pots were investigated in a CERN hadron test beam. An important parameter for efficient tracking is the efficiency of the fibre layers. Here a typical value of 94 % was measured. The resulting tracking efficiency is close to 100%.

²⁾Hamamatsu R7600, ³⁾Hamamatsu R7400, R9880

Another performance parameter is the spatial resolution. For these studies the EUDET Silicon Pixel telescope [3] was used as an external reference. The ultimate resolution in the centre of the telescope is about $2\ \mu\text{m}$. Due to space constraints the ALFA stations had to be placed in a distance of 1.2 m to the telescope. At this distance the EUDET resolution is about $8\ \mu\text{m}$. The residuals of the ALFA coordinate measurement in respect to the extrapolated EUDET tracks are shown in fig.3. Typically values around $30\ \mu\text{m}$ were achieved, best values are at $25\ \mu\text{m}$. The difference to the theoretical resolution of $14\ \mu\text{m}$ is caused by deviations from the regular staggering, noise contributions and cross talks from physics processes and in the MAPMTs.

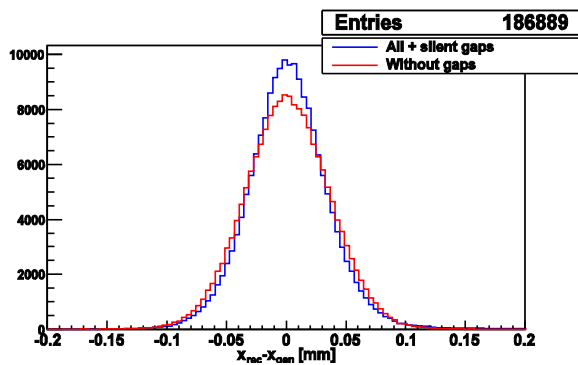

Fig.3 Typical resolution of an ALFA fibre detector.

Another important parameter to access lowest t -values in the Coulomb region is the sensitivity of the fibre detectors at the edge close to the beam. For the same reason the gap at the detector edge to the Roman Pot window has to be minimized. A tomography image of the fibre detectors and the Roman Pot windows reconstructed from the EUDET reference tracks is shown in fig.4. The large flat plat tops corresponds to tracks triggered by the main trigger tiles while the small peaks are related to particles interacting in window and trigger the readout by shower particles. The first preliminary results confirm a good edge smearing of about $25\ \mu\text{m}$. Furthermore the gap between the bottom window and the detector edge can be measured directly and compared with the values from the 3D survey. The nominal value of the gap is $150\ \mu\text{m}$. Sometimes deviation on the order of $50\ \mu\text{m}$ were observed in the tomography plots. The calibration of the overlap detectors is another purpose of the test beam analysis. Before the assembling of the detectors all fibre positions were measured by microscope and the position of tracks is well-known in the coordinate system of individual plates. However the assembling can introduce small additional offsets which in turn change the position of the reconstructed track. Especially for the overlap detector with only 3 fibre layers the correction of additional offsets is of importance. Monte Carlo simulations have shown that

after calibration the distance measurement can achieve a precision of $5\ \mu\text{m}$.

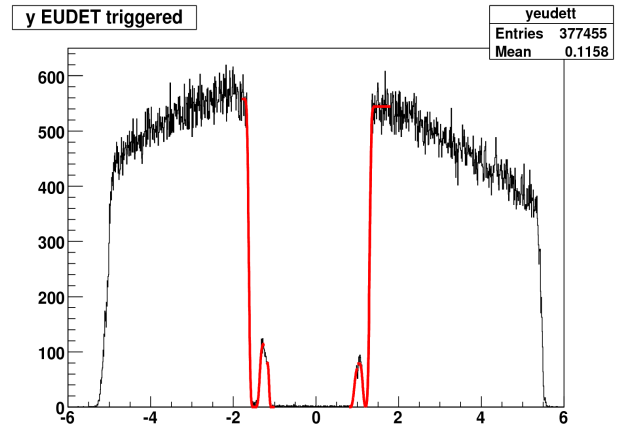

Fig.4: Vertical tomography of upper and lower detector edges with small peaks indicating the windows.

STATUS OF INSTALLATION

The installation in the tunnel started with the integration of the the Roman Pot stations in the ring of LHC beam pipes. While the LHC vacuum was protected by closed valves a short intermediate piece of the outgoing pipe was removed and replaced by a Roman Pot station.

The insertion of the Roman Pots itself into the stations is a time-consuming operation. First there is a very small clearance between the thin bellows and the sharp outer edges of the Roman Pots. And second also the thin $200\ \mu\text{m}$ windows of the Roman Pots have to be protected against mechanical impact. The pots were closed by blind flanges and pumped until a pressure of few mbar in the Roman Pots. This secondary vacuum is needed to prevent the windows against bending inside the beam pipe by the atmospheric pressure.

Due to the tight mechanical environment at the positions of the ALFA stations the installation of the stations including insertion of Roman Pots took about 2 weeks. The subsequent bake out of the stations and surrounding elements lasted about 5 days and was finished in December 2010.

The first activity in 2011 was the insertion of the fibre detectors. Since the fibres and the trigger tiles are glued on Titanium plates mechanical impact on these structures must be avoided. Also here the clearance is in some cases only a few hundred μm . The insertion of the detectors took about one day per station. The insertion of a lower fibre detector is shown in fig.5.

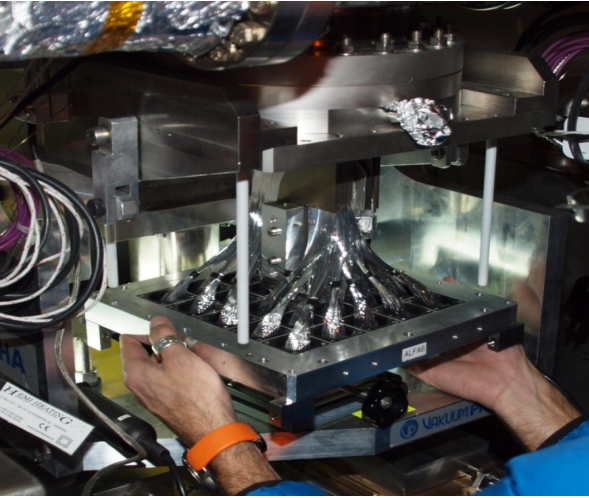

Fig.5: Insertion of a lower fibre detector in the RomanPot.

The next activities were related to the readout electronics. The so-called base plates with all MAPMTs were put onto the detector frame with all the fibre feedthroughs. The front-end electronics of all MAPMTs is connected by flat Kapton cables to the motherboard where data are packed and prepared for the readout.

The main trigger signal for each detector is formed by a coincidence of signals in both trigger tiles. These signals are sent in air-core cables to a VME crate in USA15 and further to the ATLAS Central Trigger Processor (CTP). The CTP produces the L1A trigger signal which is sent by optical fibres back to the ALFA stations to start the data readout from the motherboards. The data packets are transferred via fibre optics to the Read OUT Drivers (ROD) and further to the central ATLAS TDAQ.

An important condition for the measurements with the ALFA detectors is the knowledge of the detector positions in the LHC coordinate system. Apart from the detector positioning this information is also a safety issue for LHC. This positioning was done in two steps. First all stations were aligned to the nominal LHC beams. This can be arranged by a level gauge and the known positions of beam line elements on both sides of the ALFA stations. The second step is the calibration of the detector positions to the nominal LHC beams. For this procedure a laser tracker has been used. The laser tracker measures positions and angles of the detectors via 3 laser targets fixed to the Roman Pots. The positions of these targets have been precisely measured in the Roman Pot coordinate system by a 3D device. For the position measurement of the movable Roman Pots so-called Linear Variable Differential Transformers (LVDT) are used. A sliding core results in changes of the induced voltages in the secondary

coils. This voltage ratio will be calibrated to the distance of the outer Roman Pot window to the nominal beam position obtained from the laser measurements.

After the cabling of the electronics and low level connectivity tests the commissioning of the detector readout was performed. The main tool for this purpose are the online histograms implemented in the ATLAS TDAQ. For these tests the TDAQ is running in a standalone partition without affecting the central ATLAS TDAQ. Without particles from the LHC beams the detector commissioning is based on LED data. Each detector is equipped with 2 LEDs which are located inside the Roman Pot with the fibre detectors. The LEDs flash the whole volume of the Roman Pot and light enters the MAPMTs via the transparent glue in the fibre feedthroughs. Such LED pulses generate a typical pattern with more intensive light in two cones on both sides of the detector arm as shown in fig. 6.

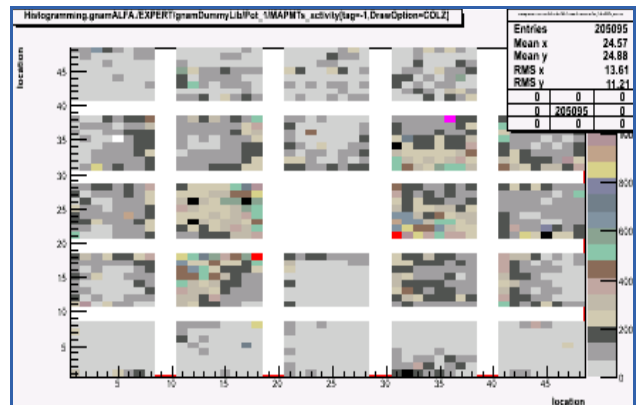

Fig.6: MAPMT images produced by pulsed LED signals illumination the fibres inside the Roman Pot.

The LED pulses are also used to adjust the latencies and to synchronize the data readout of all 8 ALFA detectors. Latencies are roughly adjusted in 25 nsec bunch crossing units given by the 40 MHz LHC clock. The fine timing is organized by firmware and shifts the phase of the LHC clock inside a certain bunch crossing. The LED signals are also used to verify the threshold behaviour of the faint light signals passing the MAROC front-end chip. For this purpose the LEDs are tuned to low light level below the 1 photo-electron signal. In so-called S-curves measurement the MAROC threshold is step by step enlarged and the rate shows a typical behaviour. With the increase of the threshold first the pedestal signal disappears, than a flat part with equal efficiency follows before the signal drops to zero at high threshold. At the end point the threshold increase is extremely steep and even large signals are rejected. The S-curves are different in the flat part due to the varying amount of light in

dependency on the fibre position in the Roman Pot. A band of S-curves of one MAPMT is shown in fig.7.

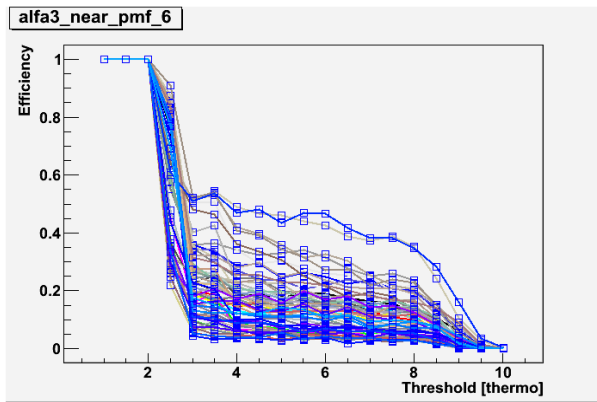

Fig.7: S-curves indicating the 1 photo-electron threshold and saturation around 2.5 and 9.5 thermo.

DATA TAKING 2011

The final goal of the luminosity measurement can only be performed in special runs with the very high β and low specific luminosity. The special optics has to be prepared by simulations followed by dedicated machine studies. Before the very high β optics it is foreseen to have data taking with an intermediate β of 90m together with the TOTEM experiment. Taking into account all the necessary steps of commissioning with LHC beams the intermediate β run seems to be a realistic goal for 2011. The experience in this process will allow a better prediction of the time scale for the ultimate $\beta = 2625$ m run.

The 2011 time line of integration steps into the ATLAS CTP and TDAQ and the evolution of detector positions is summarized in table 1.

Tab.1: ALFA commissioning steps in 2011

Step	Position	Trigger	DAQ	Goal
1	Garage	ALFA NIM	Local stream	Rate
2	Garage	any ATLAS	Local stream	Trigger bits, latency
3	~10mm	ALFA NIM	Local stream	Rate
4	~10mm	ALFA in menu	Local stream	Trigger bits, latency
5	~10mm	ALFA in menu	ATLAS stream	Latency
6	~10mm	ALFA in menu	ATLAS stream	ATLAS latency
7	Close to beam	ALFA in menu	ATLAS stream	cross section

There are three relevant parameters which can be changed: the detector position, the trigger processor and the data stream. The detector position will change from the garage position to out of garage in a safe distance to the beam and finally close to beam for a physics run. For the trigger handling there are 2 options. Since the signals are split before entering the CTP and the readout can be triggered by a local NIM logic, or after integration by a L1A signal of CTP menu. The logging of data can be performed fully locally. After the implementation in the ATLAS trigger menu the ALFA data are integrated in the global ATLAS data stream.

All the commissioning steps until the β 90m run will be performed during normal ATLAS data taking with collision optics.

In the garage position only fragments of shower particles can hit the detectors. With a local NIM based trigger logic one can watch the rates and check the performance of individual detectors. The composition of the trigger bits at the input to CTP can be investigated. Later, still in garage position the data readout can be triggered by any ATLAS L1A trigger. In this spy mode the fraction of events with activity in the ALFA detectors will be low since the coincidence rate of the L1A signal with showers at the ALFA positions is accidentally. These runs can be used to exercise the adjustment of latencies.

In the next step the detectors are moved out of the garage but are still fully in the shadow of the collimators. Shower and halo particles can hit two neighbouring detectors in coincidence. The first measurements aims for feedback about the coincidence rate as an input for a more precise estimation of the radiation dose. In runs with standard collision optics and high specific luminosity the radiation is a critical parameter for the positions of the fibre detectors. Preliminary estimates indicate that the detectors in a distance of ~ 10 mm ($\sim 30 \sigma$ of the beam envelope) to the beam are irradiated by an acceptable low rate. After the rate measurement with local trigger logic data taking continues in spy mode by ATLAS L1A triggers. The latencies will be checked and tuned for halo particles. In the next step the ALFA readout will be first time triggered using an ALFA trigger from the central ATLAS CTP menu. In these runs the final ALFA latency adjustment will be performed. Due to the large distance of the ALFA stations from the IP the latency is on the order of 10 bunch crossings behind the present ATLAS latency. In a temporary phase without correcting the latencies of all ATLAS detectors only the ALFA data are meaningful. To make sure that the data from all ATLAS detectors belong to the same event all latencies have to be adapted to the ALFA latency. This is the last commissioning step before ALFA is ready for a physics run with β 90m optics.

ACKNOWLEDGEMENTS

In the very first commissioning step with LHC beams the readout of ALFA data will be triggered by an OR of all detectors in all stations. This is necessary for an overall adjustment of the latencies of all detectors to ensure that data from all detectors belong to the same event. For this purpose ALFA will feed 8 trigger signals of all detectors via the PIT bus to the CTP. The trigger for halo particles can be arranged by coincidences of 2 neighbouring detectors and the amount of inputs to CPT can be reduced to 4 PIT bus units. The final ALFA physics trigger is shown in fig.8.

The construction of the ALFA stations, detectors and electronics has been performed by people from many institutions: CERN, DESY, LAL Orsay and universities in Berlin, Giessen, Lisbon, Krakow, Prague and Olomouc. The author acknowledges the good preparation and the smooth procedure of the installation and commissioning in the LHC tunnel. A special thanks for plots and photos to H.Stenzel, M.Heller, K.Korcył and S.Jakobsen.

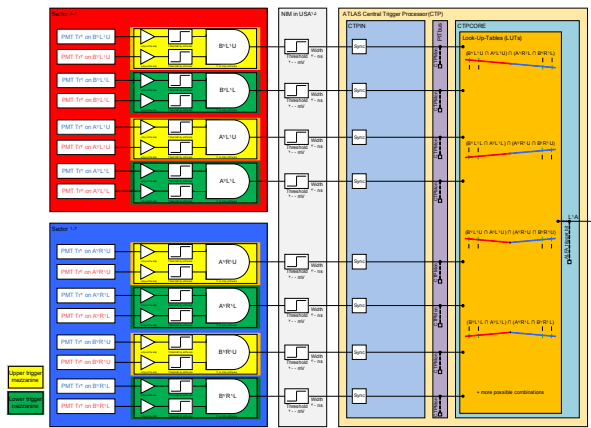

REFERENCES

- [1] ALFA Technical Design Report, CERN / LHCC/ 2008/004.
- [2] TOTEM Technical Design Report, CERN / LHCC/ 2004-002.
- [3] J.Behr, EUDET-Report-2010-01, 2010; DESY-THESIS-2010-038, 2010.

Fig.8: ALFA main trigger logic for elastic scattering.

The elastically scattered protons are characterized by coincidences of signals in all detectors on both arms. The opposite scattering angles of the outgoing protons combines in each case particles in the upper and lower detectors in opposite sides. In this case the 8 trigger inputs are compared in the CTP with pre-defined signal combinations. A L1A signal is related to elastic events and for background studies to some accidental combinations.