

Electronics and Test
/
Evaluation of HGCRROC v2
for the FoCal-E pad sensor module

박태용

Station

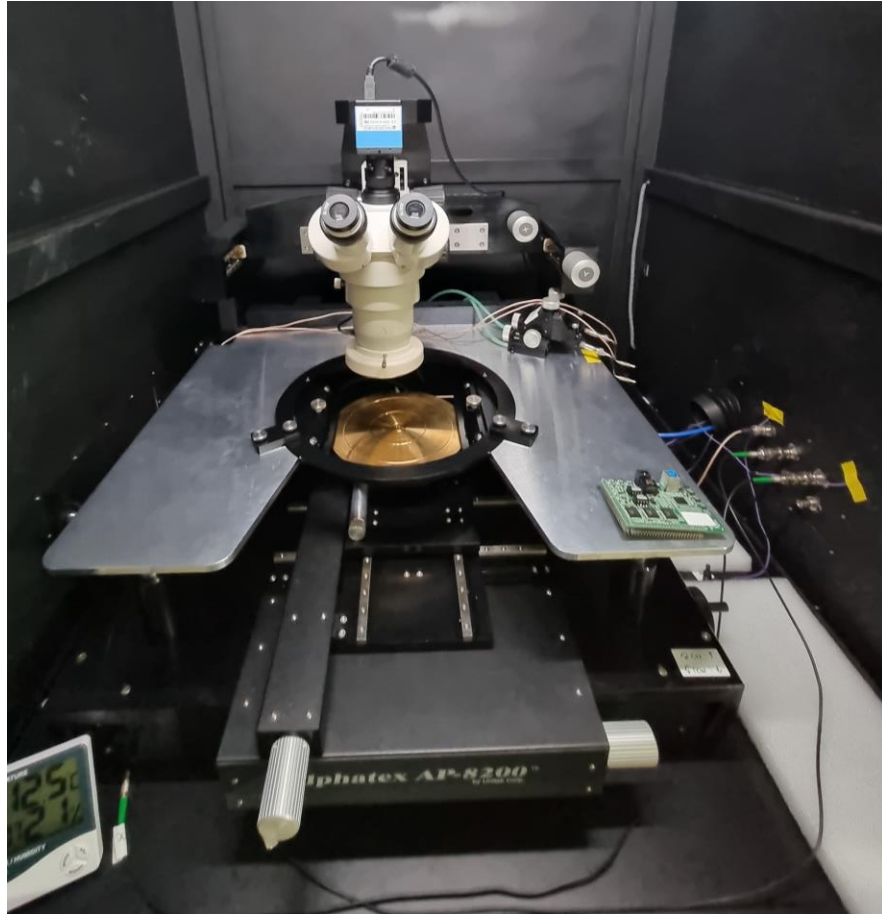

Circuit(IV)

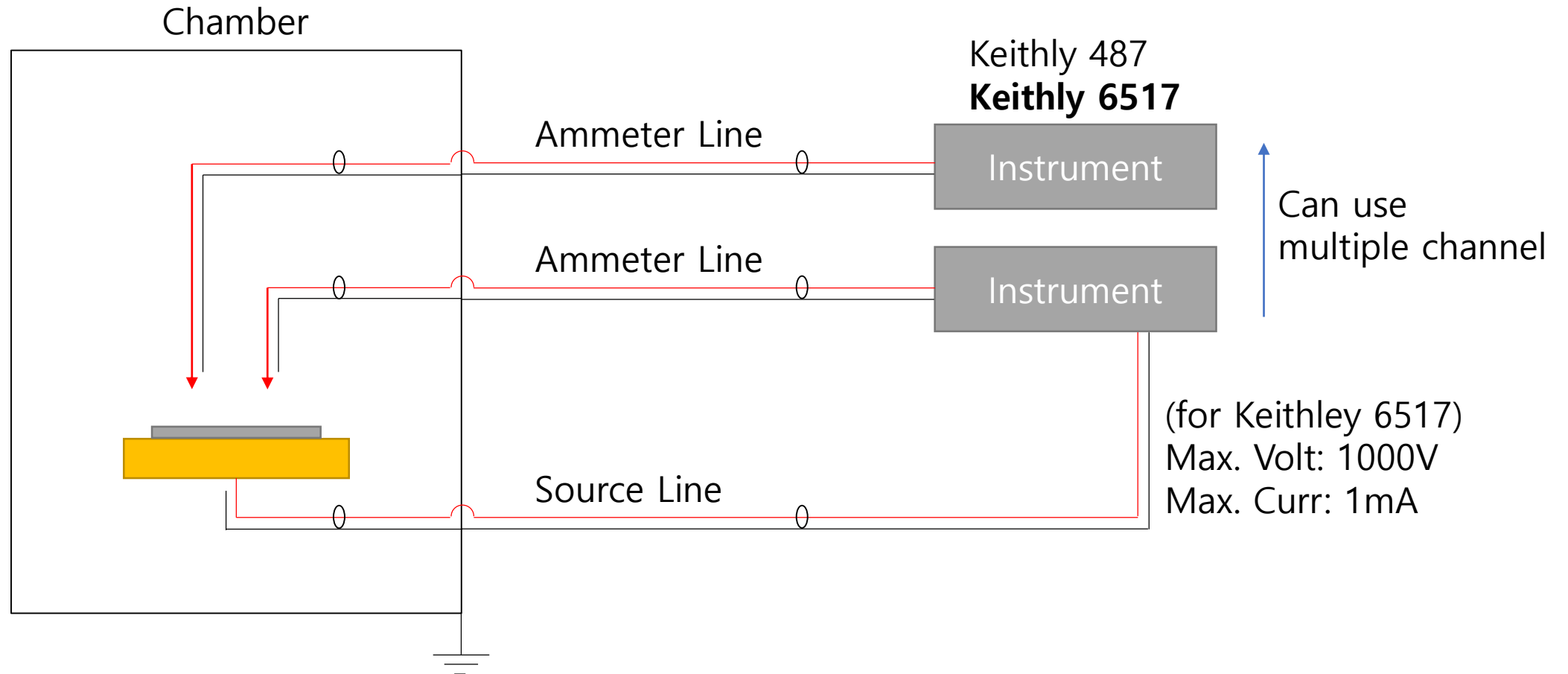

Circuit(CV)

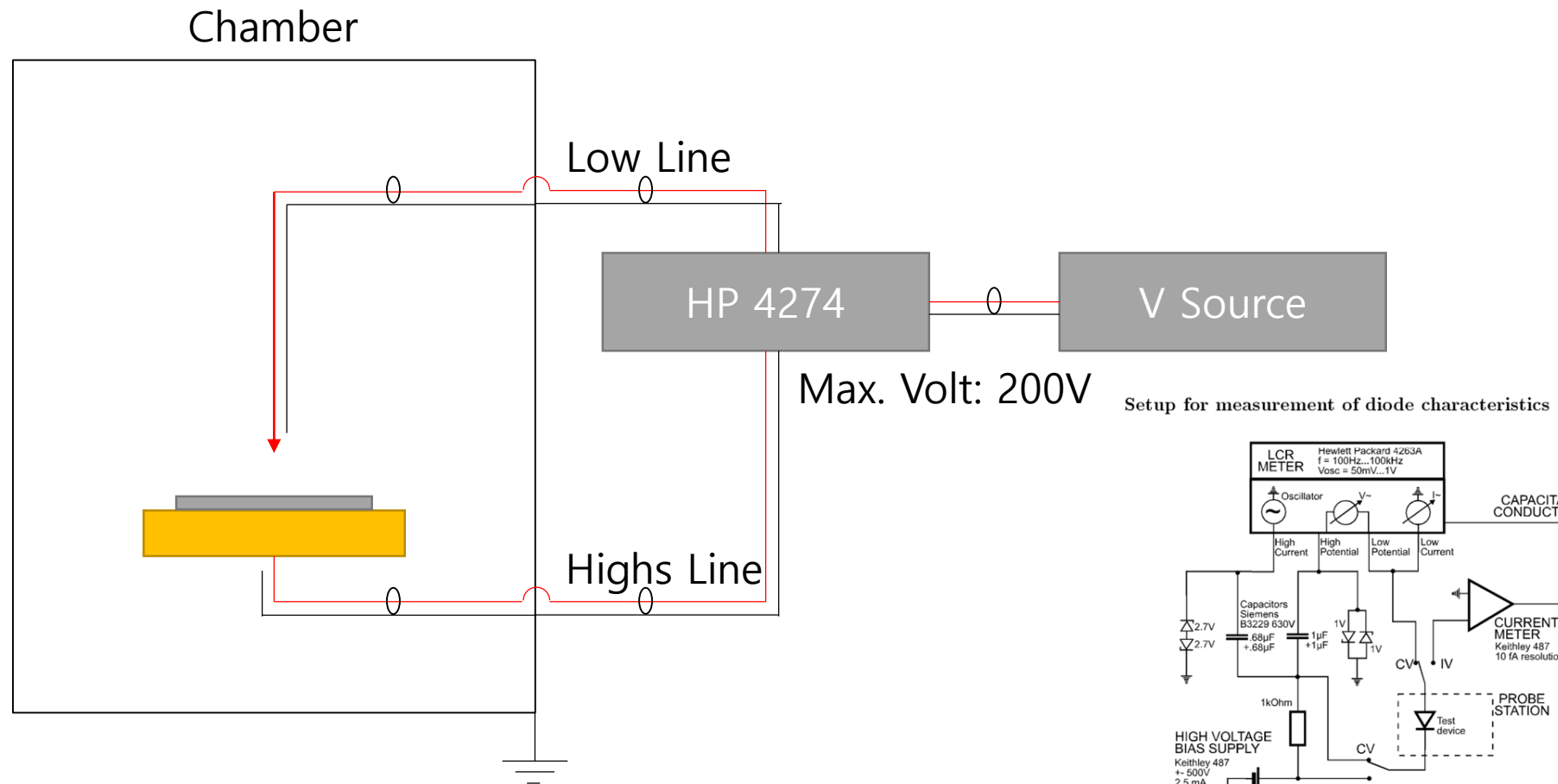
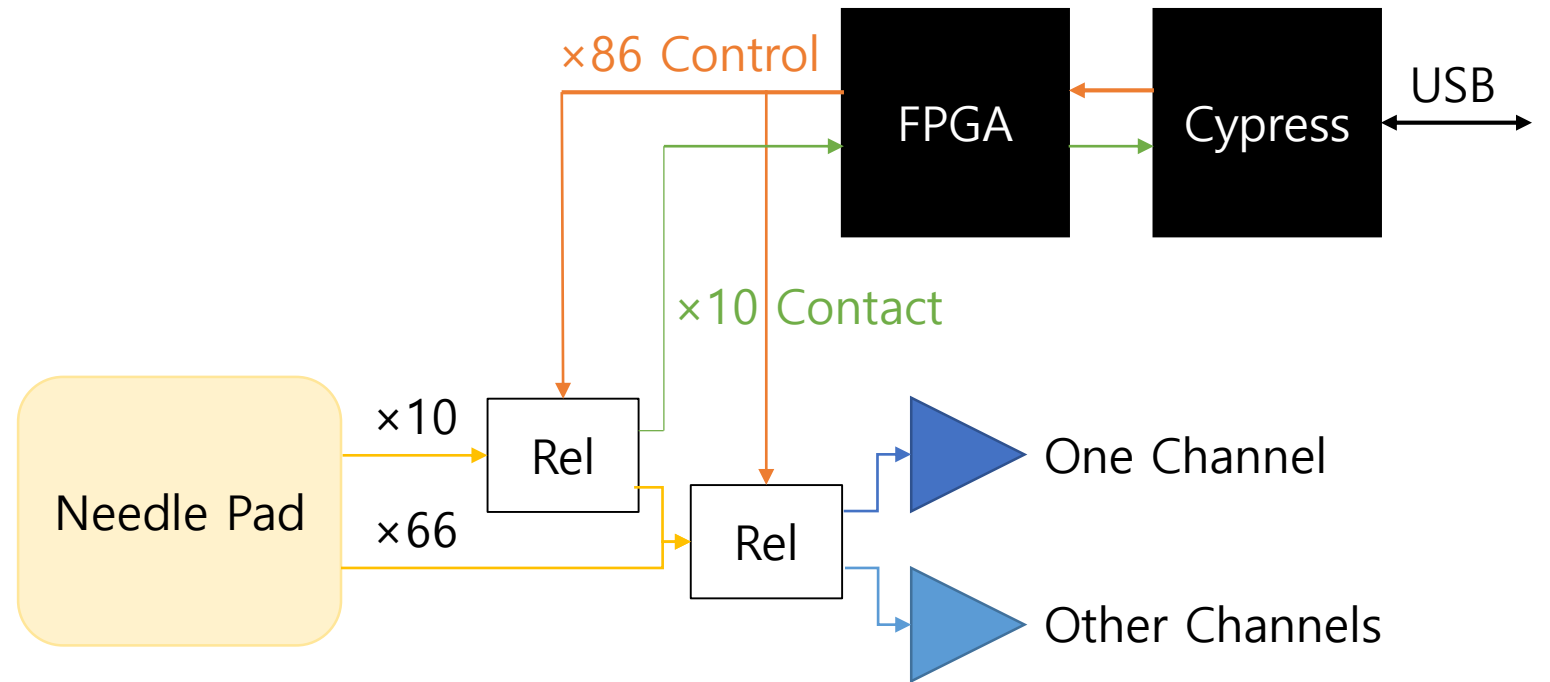
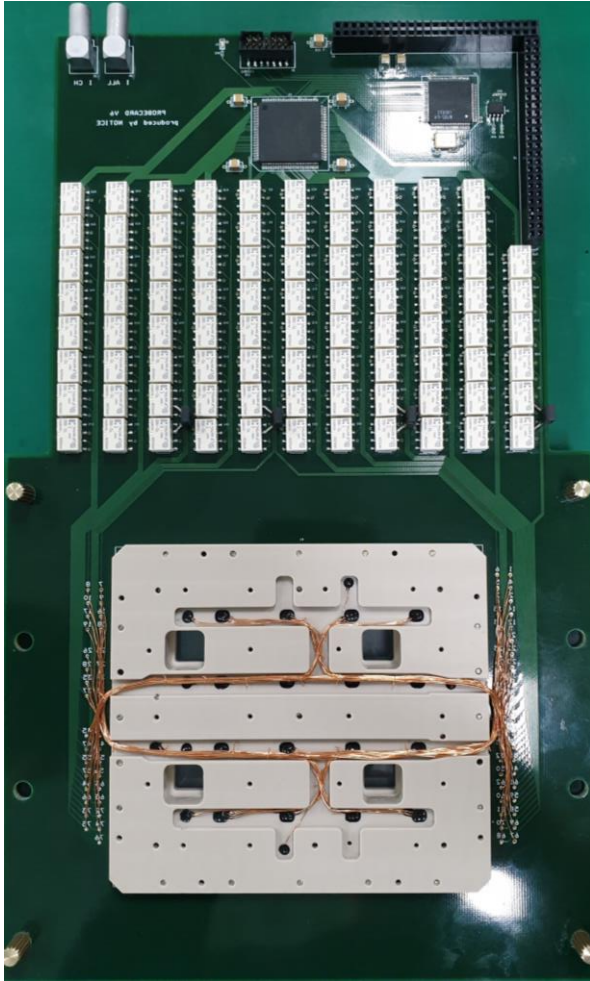
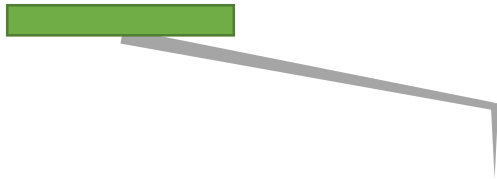

Figure 4.5: Electrical setup for C/V and I/V measurements (taken from [Fei97a]).

Probecard



Shape of needles



ALPIDE probecard
(cantilever)

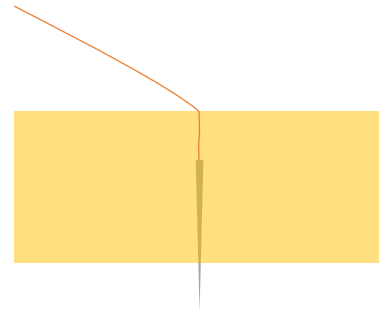

FoCal probecard
(vertical)

Proton irradiation

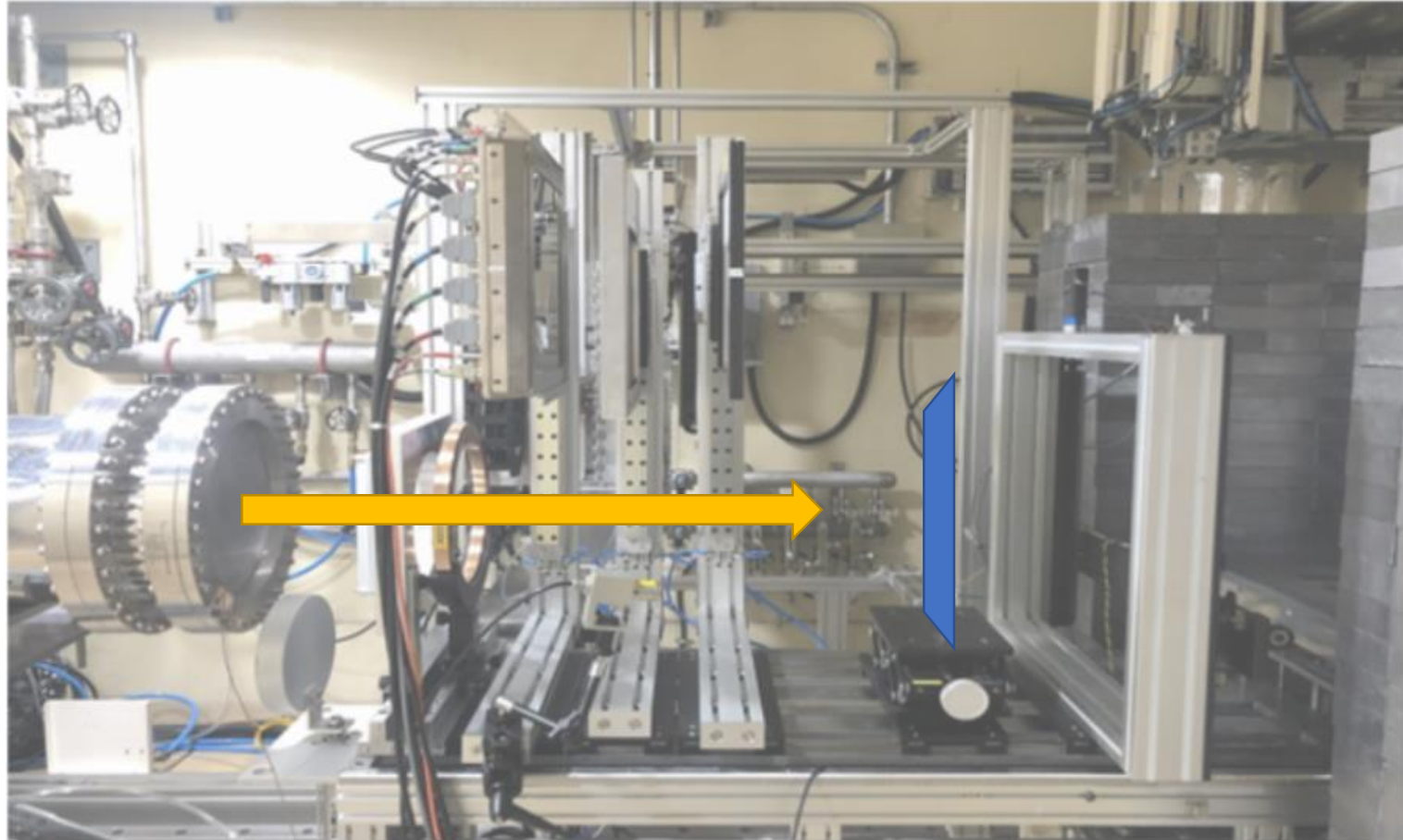

With 김동건
(한양대)

Effect of radiation

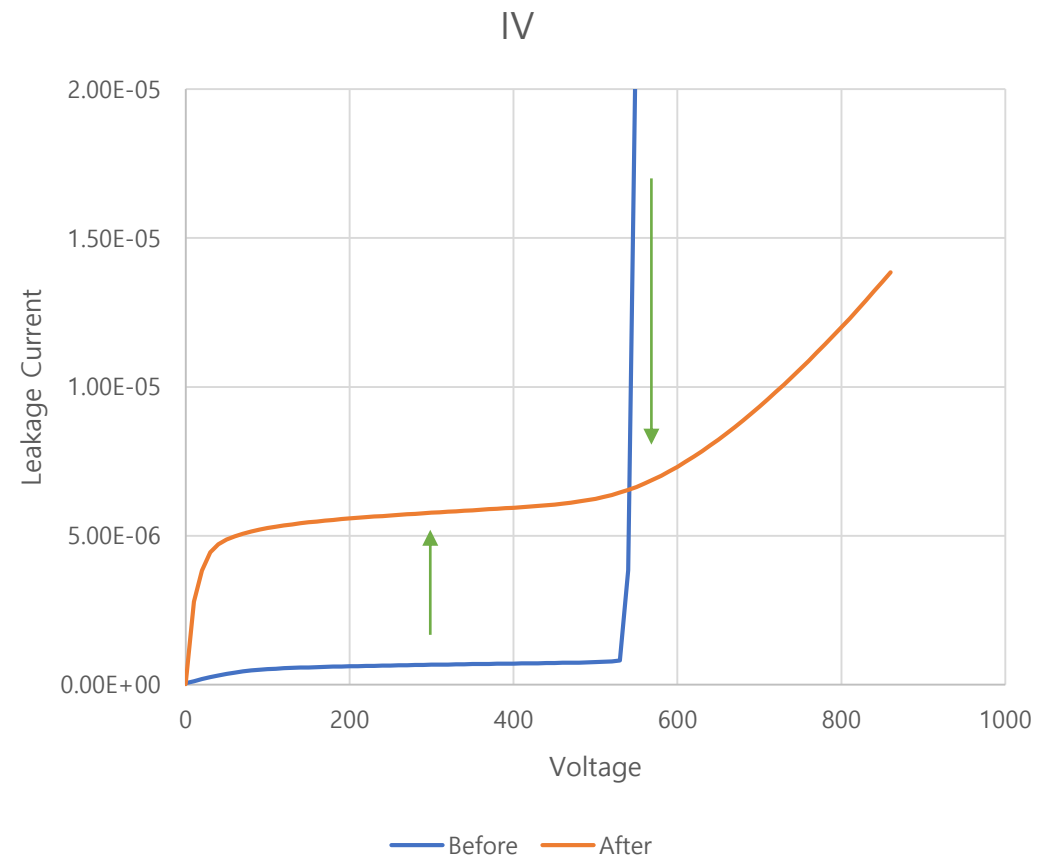
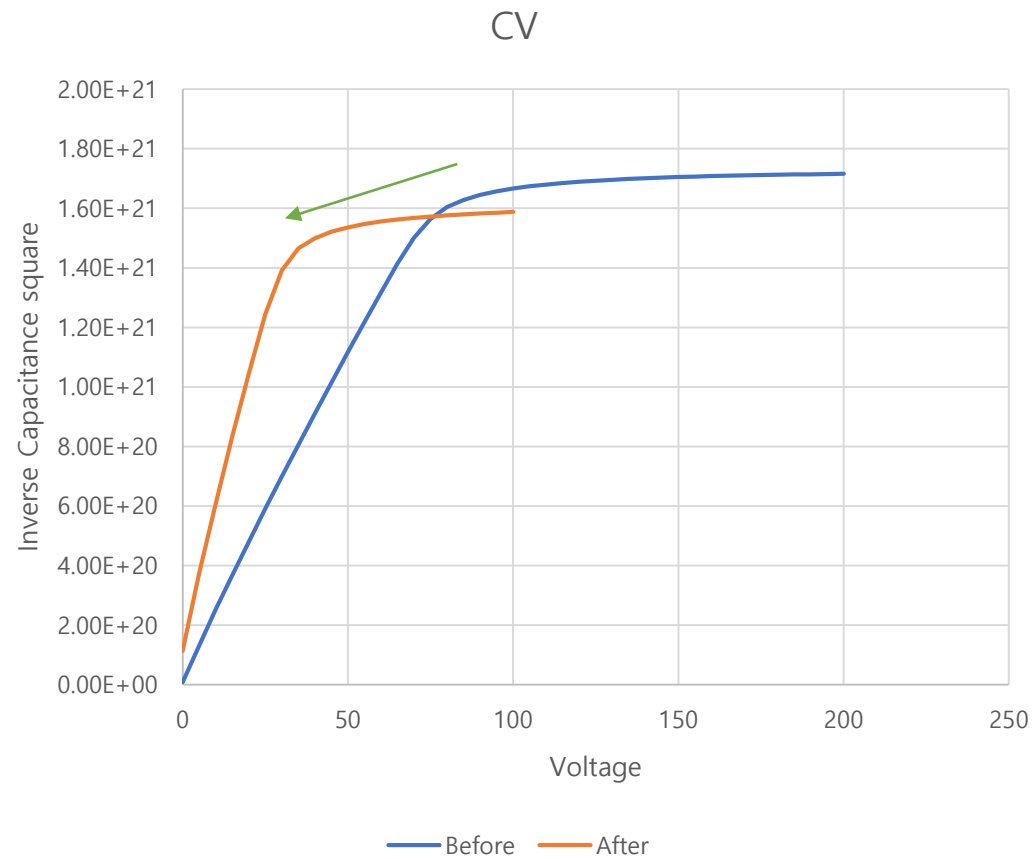

Work in progress

HGCROC testboard

