

Zero Degree Calorimeters for ATLAS

ZDC Concept

ZDC Physics

ZDC design

ATLAS TDAQ integration

ZDC performance (simulation,
rad damage, testbeam)

Planning/Installation



ZDC in ATLAS

A Zero Degree Calorimeter (ZDC) is a calorimeter that resides at the junction where the two beam pipes of the LHC become one – at 0° from the pp collisions. It is housed in the shielding unit that protects the S.C magnets from radiation, and measures neutral particle production at 0° . It can play many roles.

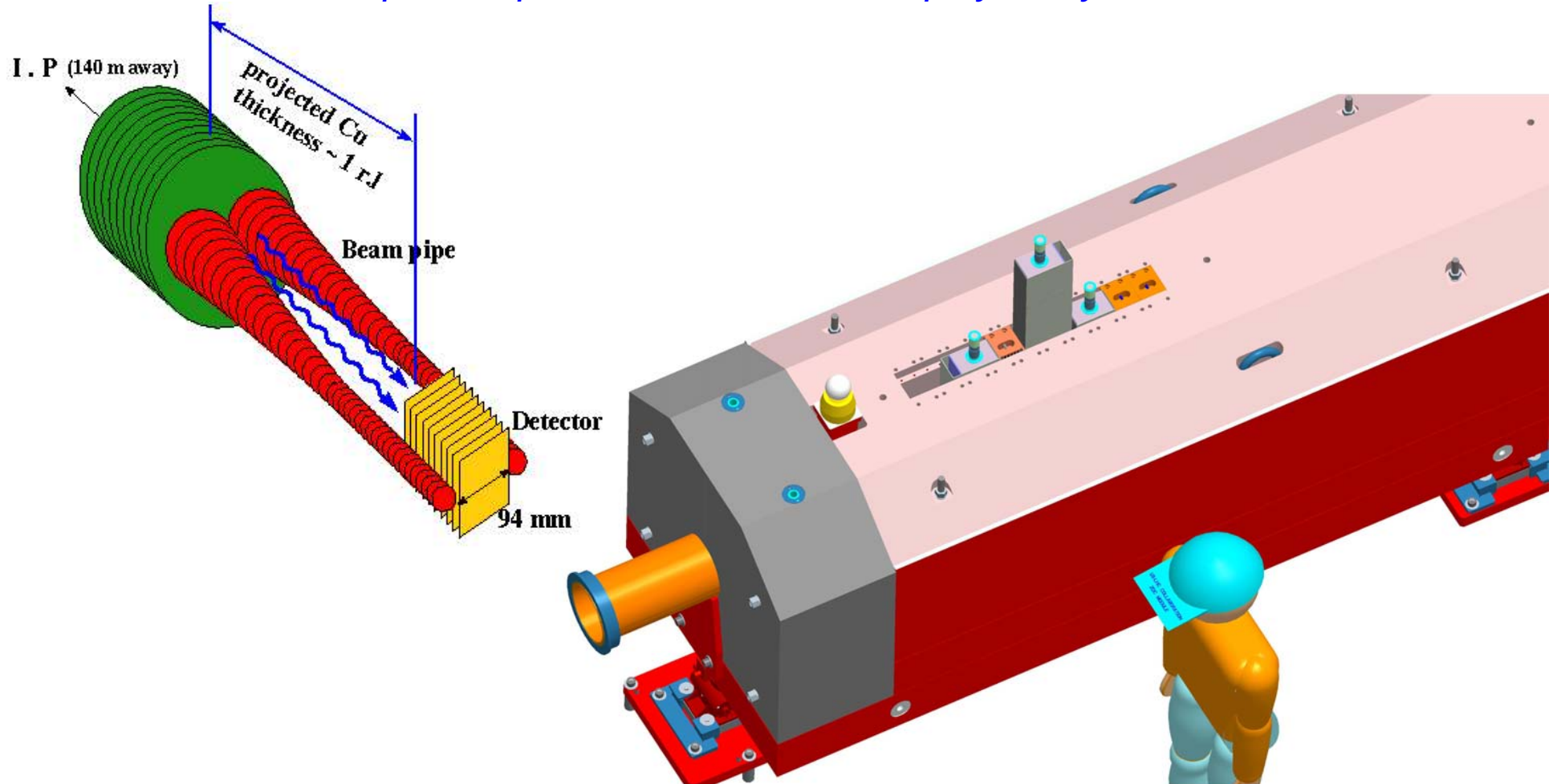

ZDC scenarios and cabling

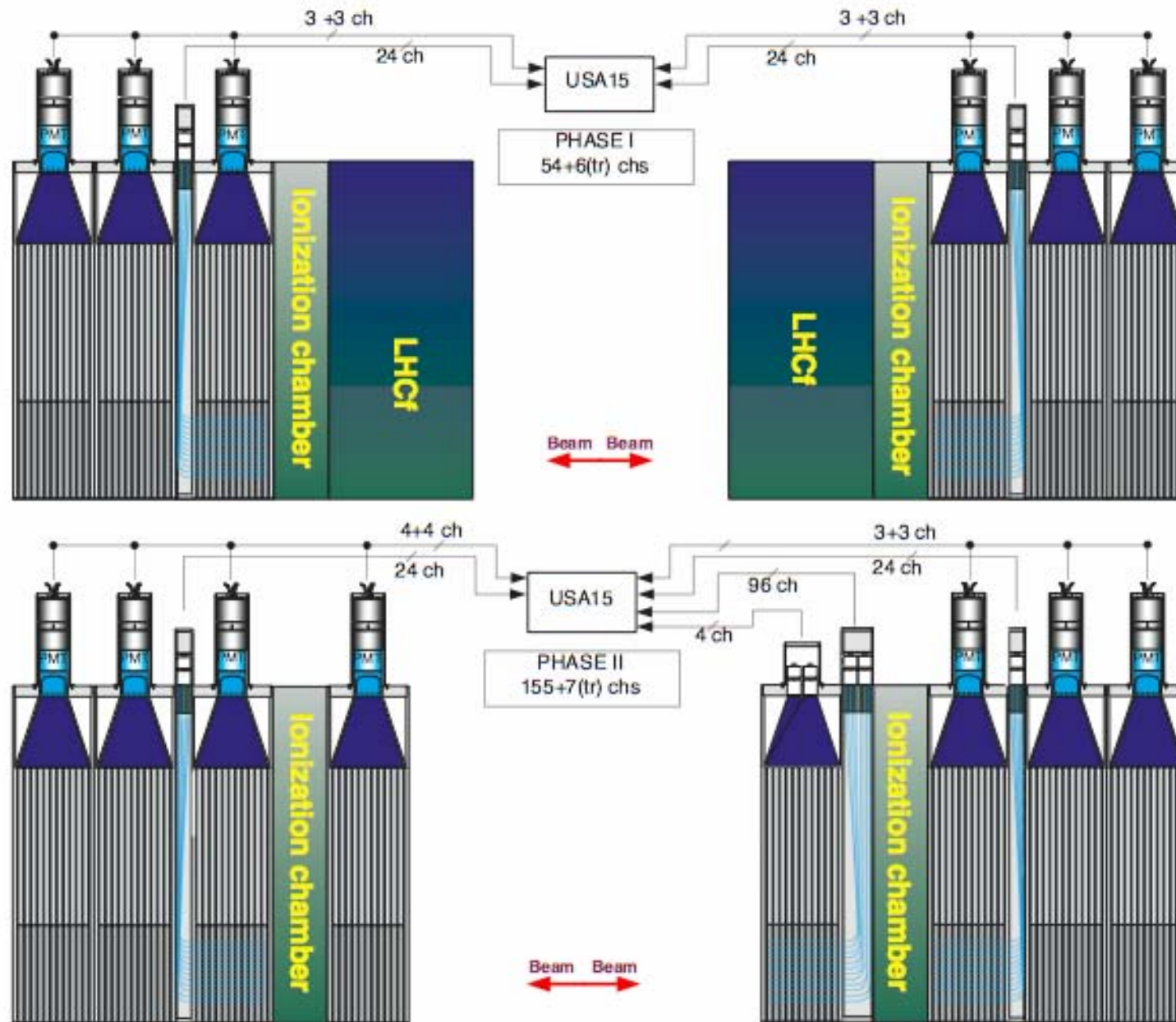

Event characterization using forward detectors

>> *Direction and magnitude of impact parameter, b*

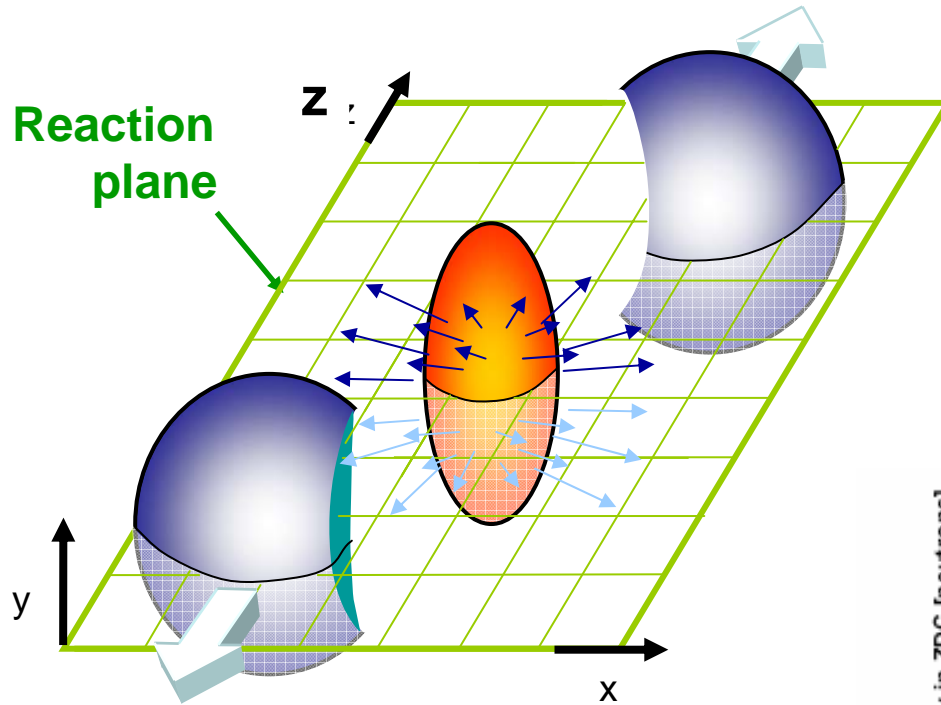

Spectator neutrons

- measure centrality,
- Min_min_bias trigger

Magnitude from complementary parameters

$$N_{\text{participant}} = 2 \cdot A - N_{\text{spectator}}$$

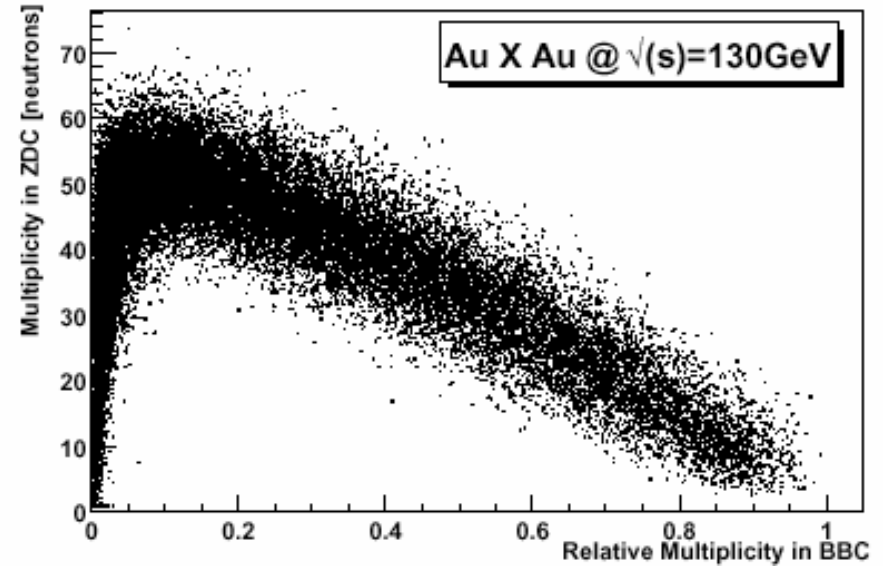

Beam-Beam Counter Mult/1000

Probing small x structure in the Nucleus with $\gamma N \rightarrow$ jets, in Ultraperipheral Collisions(UPC)

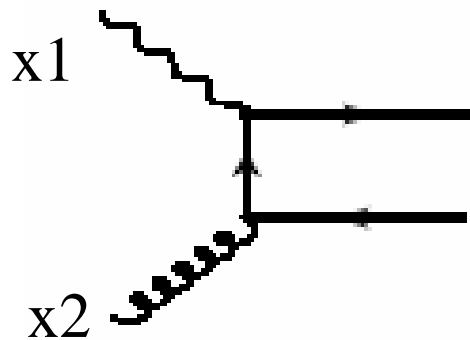

di-jet photoproduction \rightarrow parton distributions, x_2

by γ with momentum fraction, x_1

$$4p_t^2/s = x_1 * x_2$$

$$\langle y \rangle \sim -1/2 * \ln(x_1/x_2)$$

Signature: rapidity gap in γ direction (FCAL veto)

ATLAS coverage to $|\eta| < 5$ units. $P_t \sim 2$ Gev
 "rapidity gap" threshold

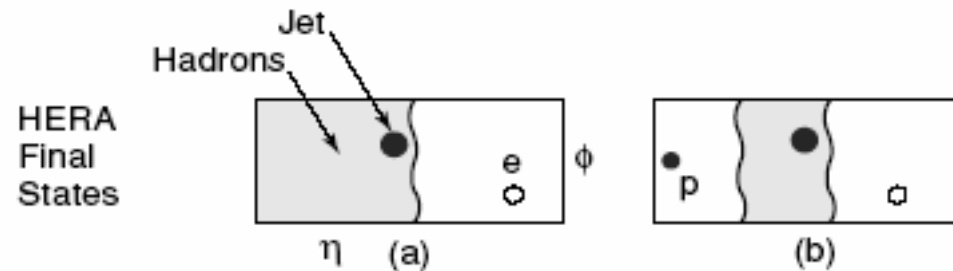

Analogous upc interactions and gap structure



diffractive



Non-diffractive

Rates and Kinematics

Event yields from a 1 month
HI (Pb-Pb) run at nominal
Luminosity ($4 \cdot 10^{26} \text{ cm}^{-2}\text{s}^{-1}$).
Counts per bin of $\delta p_t = 2 \text{ GeV}$
 $\delta x_2/x_2 = \pm 0.25$

(with M. Strikman and R. Vogt)

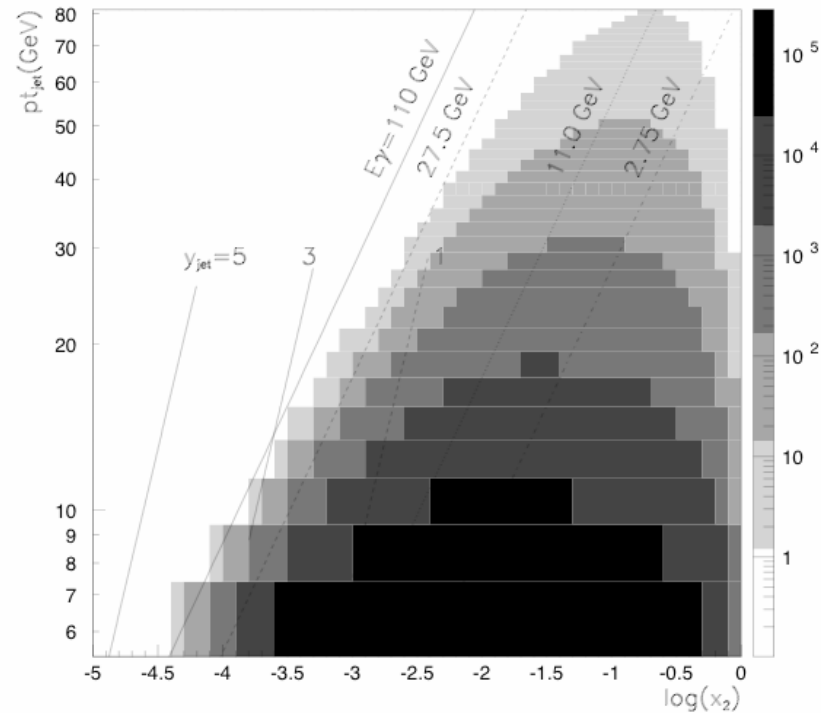

ZDC in pp(Phase II configuration)

In pp, the ZDC can measure forward production cross sections for several types of particles at very high energies. This will be useful for adjusting parameters for simulations and models, and for cosmic ray physics where the energy in one proton's rest frame is 10^{17} eV – a very interesting energy for extended air showers.

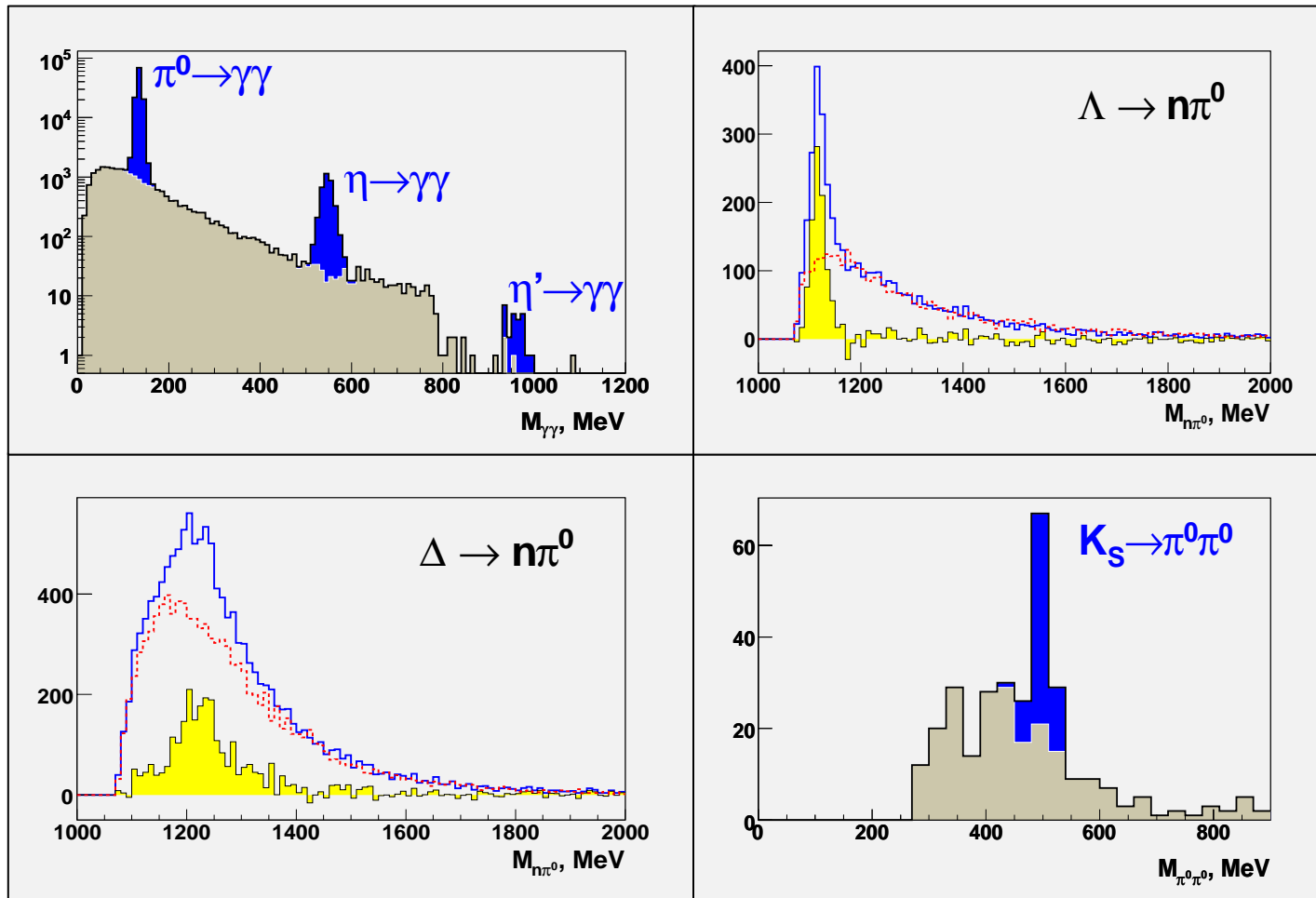

What happens when a high energy proton hits the upper atmosphere?

The ZDC can find a π^0 in the midst of several neutrons.

(1M Pythia events analyzed by a ZDC)

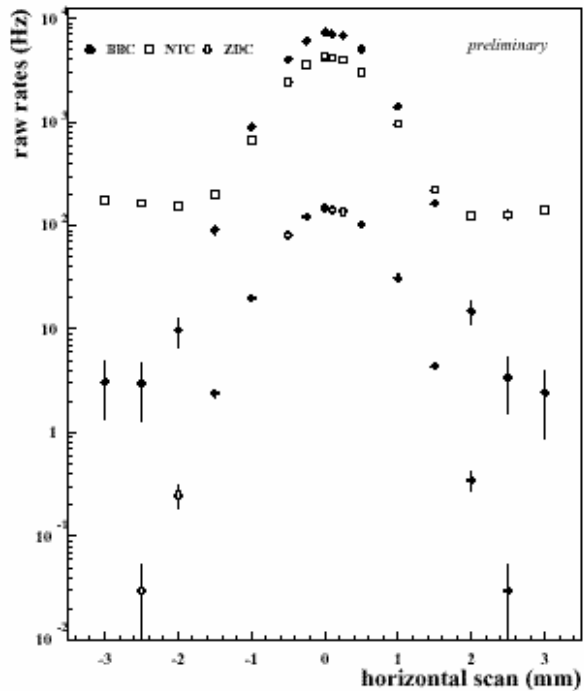

RHIC ZDC as an accelerator tool (in pp)

- Van der Meer scan (ZDC coincidence rate vs. relative beam position)
- ZDC (lower curve) bkg free over 4 orders of magnitude

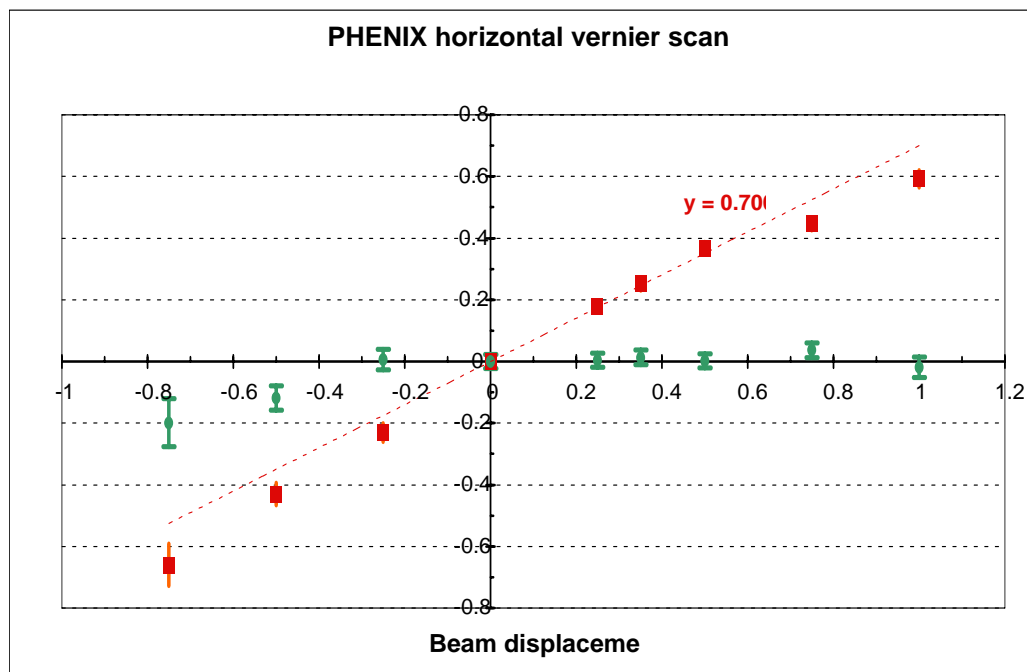

- ZDC also measures beam displacement (red points)
- Useful for crossing angle commissioning

ZDC scenarios and cabling

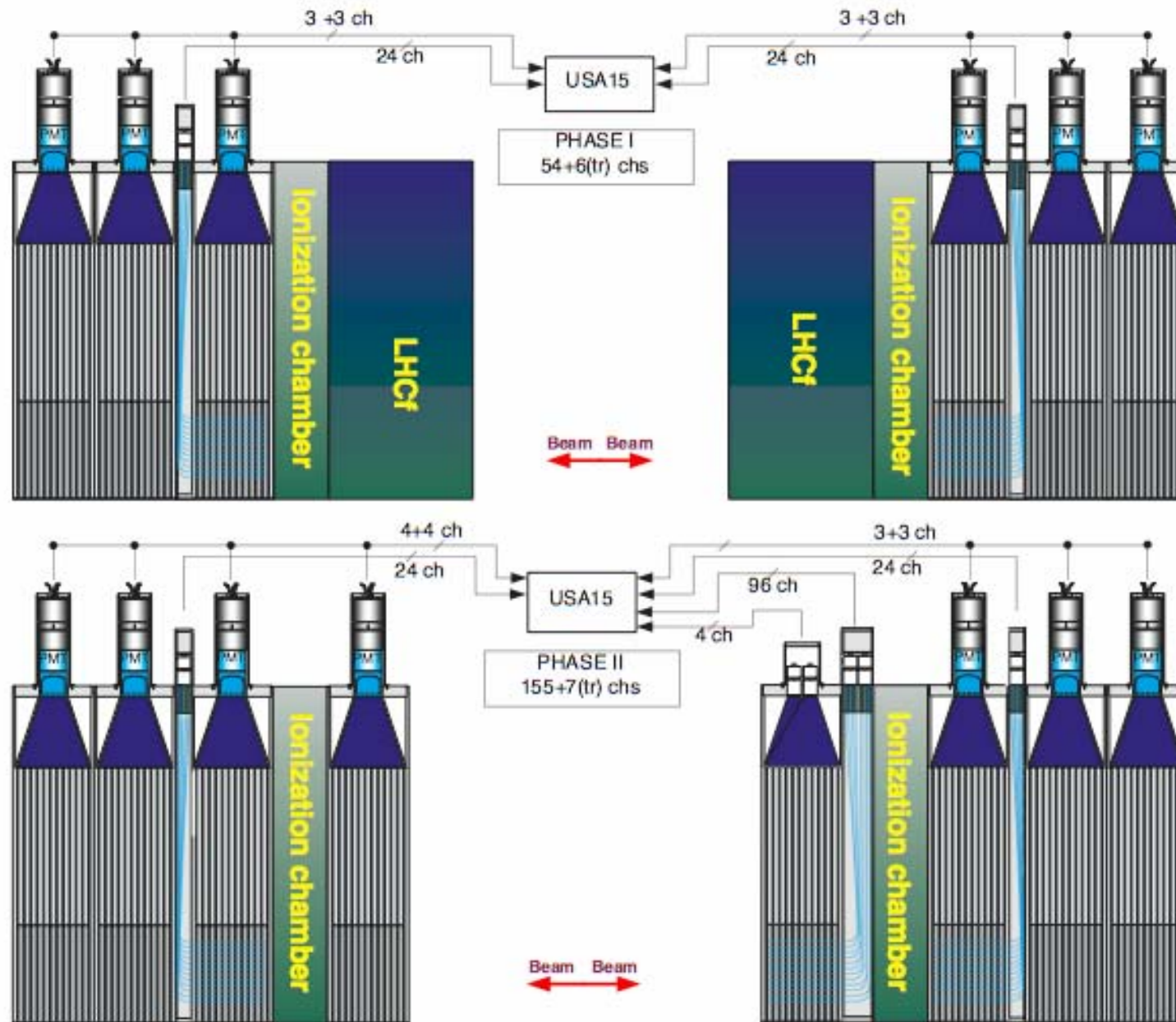

Aperture limitations from upstream components of the machine

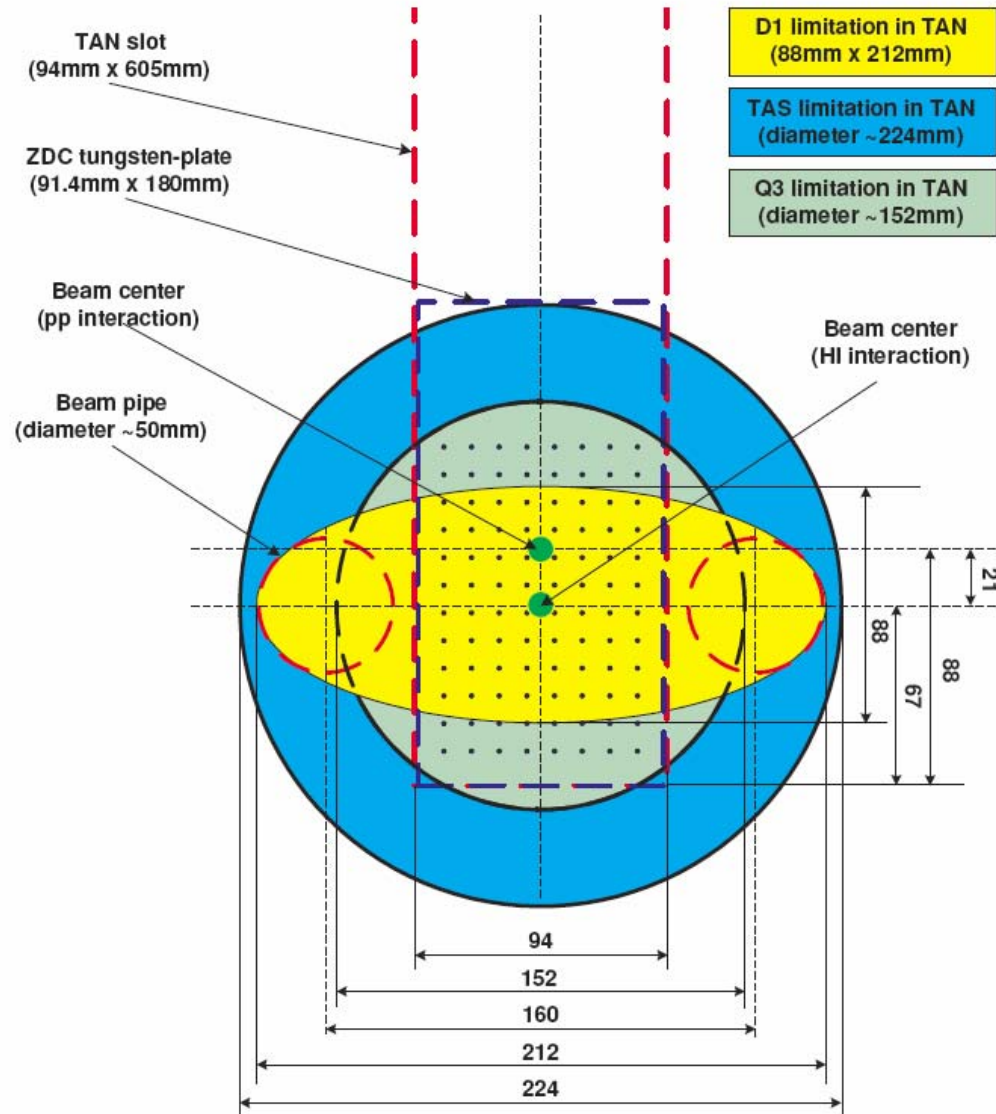

EMCal Module design (1 module only)

Light collected from
Strips of 1.5 mm quartz
Transverse to beam
(main energy and timing)

And 1 mm quartz rods
Projective to beam

Latter measure coordinate
Of showers.

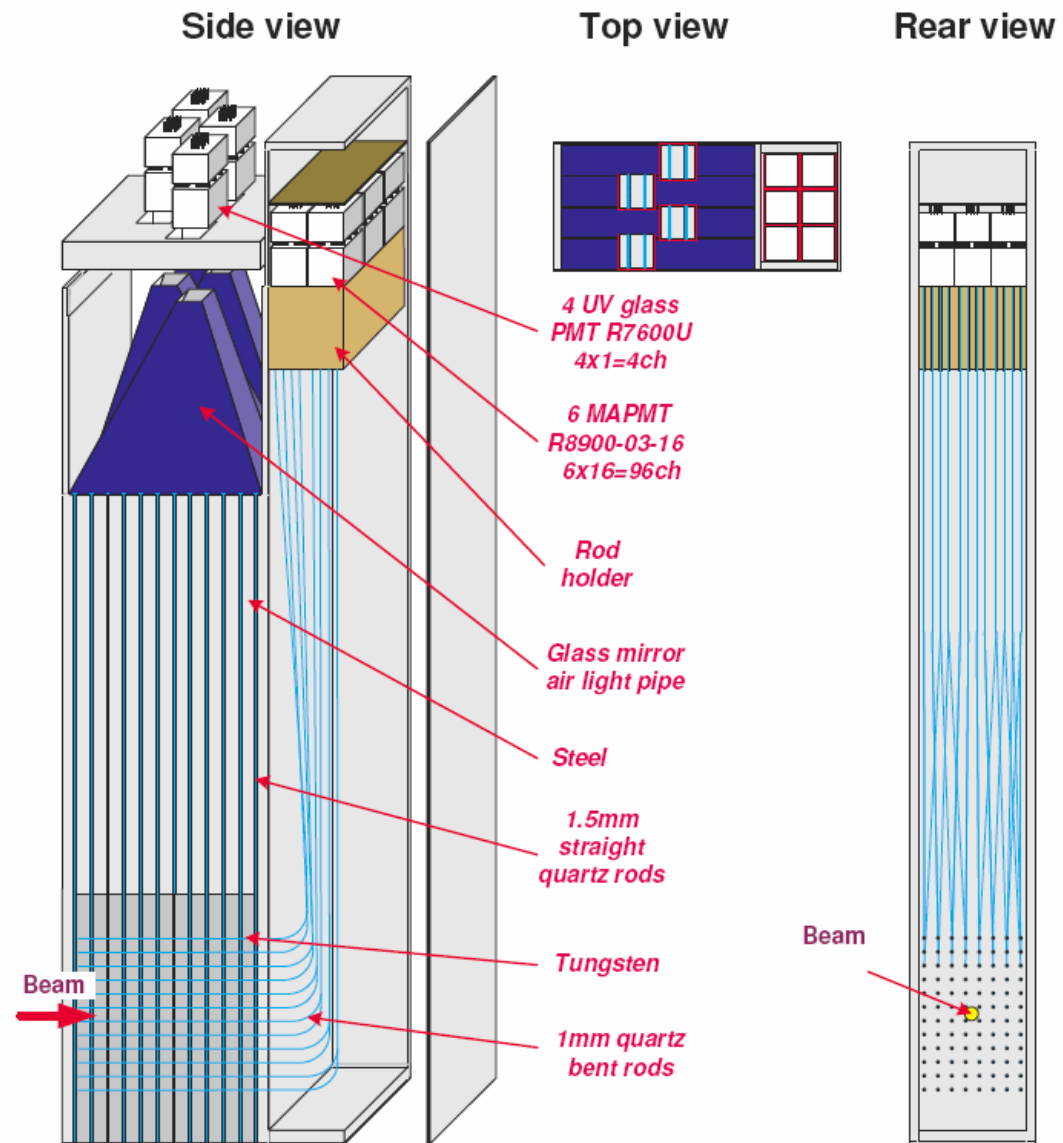

Strip detail and air
Lightguide

648 1.5 mm diameter rods

Provides main energy and
Timing measurement

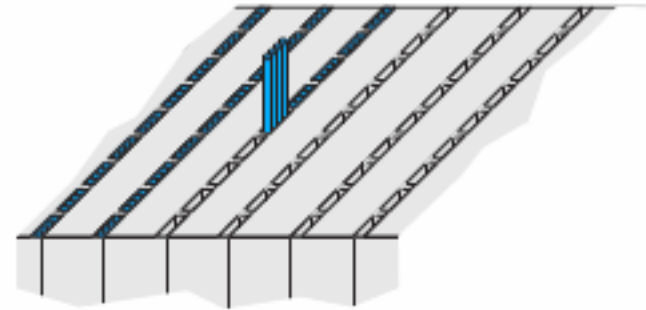
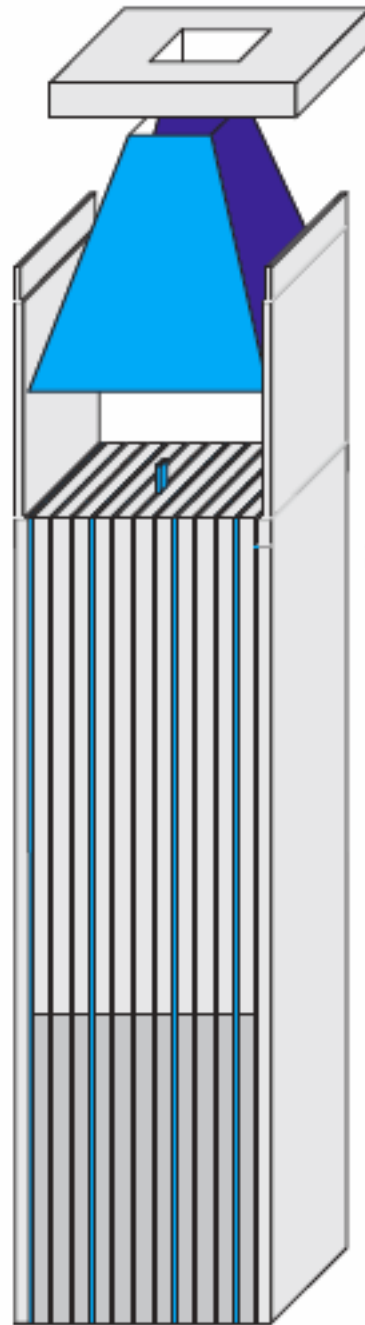

Hadronic module with
Coordinate readout
(1 module per arm)

Rods are grouped into
4 per readout pixel

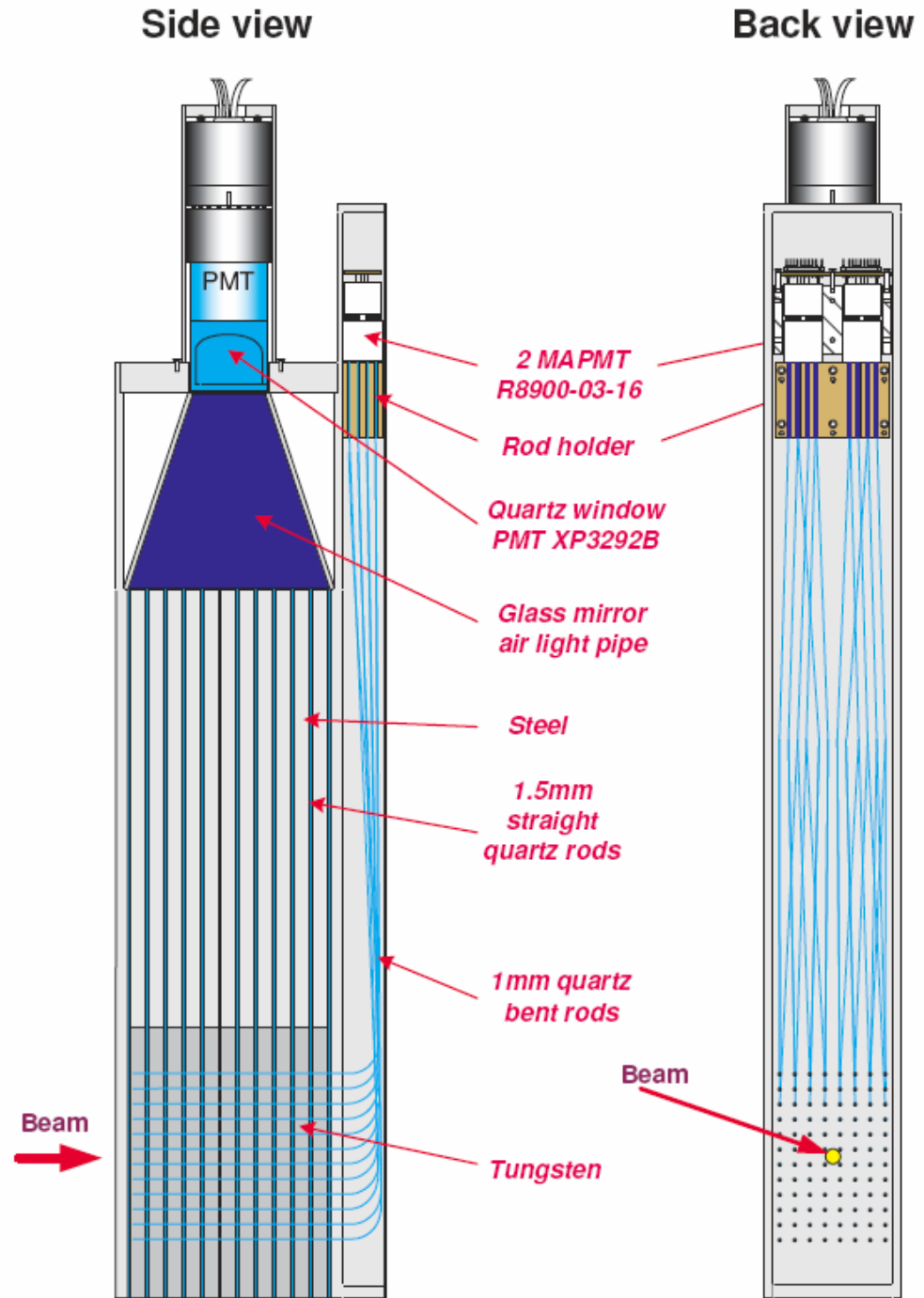

Inserting coordinate readout fibers



Summary of ZDC module parameters

	Hadronic	Electromagnetic
Number of modules	3 on each arm	1 on each arm
x-y sensing modules	1 on each arm	1 on 1 arm
Energy measuring tubes	3 on each arm	4 on 1 arm, 1 on 1 arm
Tube type	MAPMT: R8900-03-16 Single channel: XP3292B	Same Single channel: R7600U
Tot. Int. depth	4.6 λ_{int} on each arm (with EM module)	29 X_0
Module size (mm)	93.8 wide, 738 high, 150 deep	Same
Tungsten plate size (mm) 11 plates/module	91.4 wide, 180 high, 10 deep	Same
Module weight (kg)	80	Same
Number of strip (1.5 mm) rods	648	Same
Number of pixel (1 mm) rods	96	Same
Number of pixel readout channels	24 (in each arm)	96 (one arm only)

Block Diagram of ZDC Readout scheme

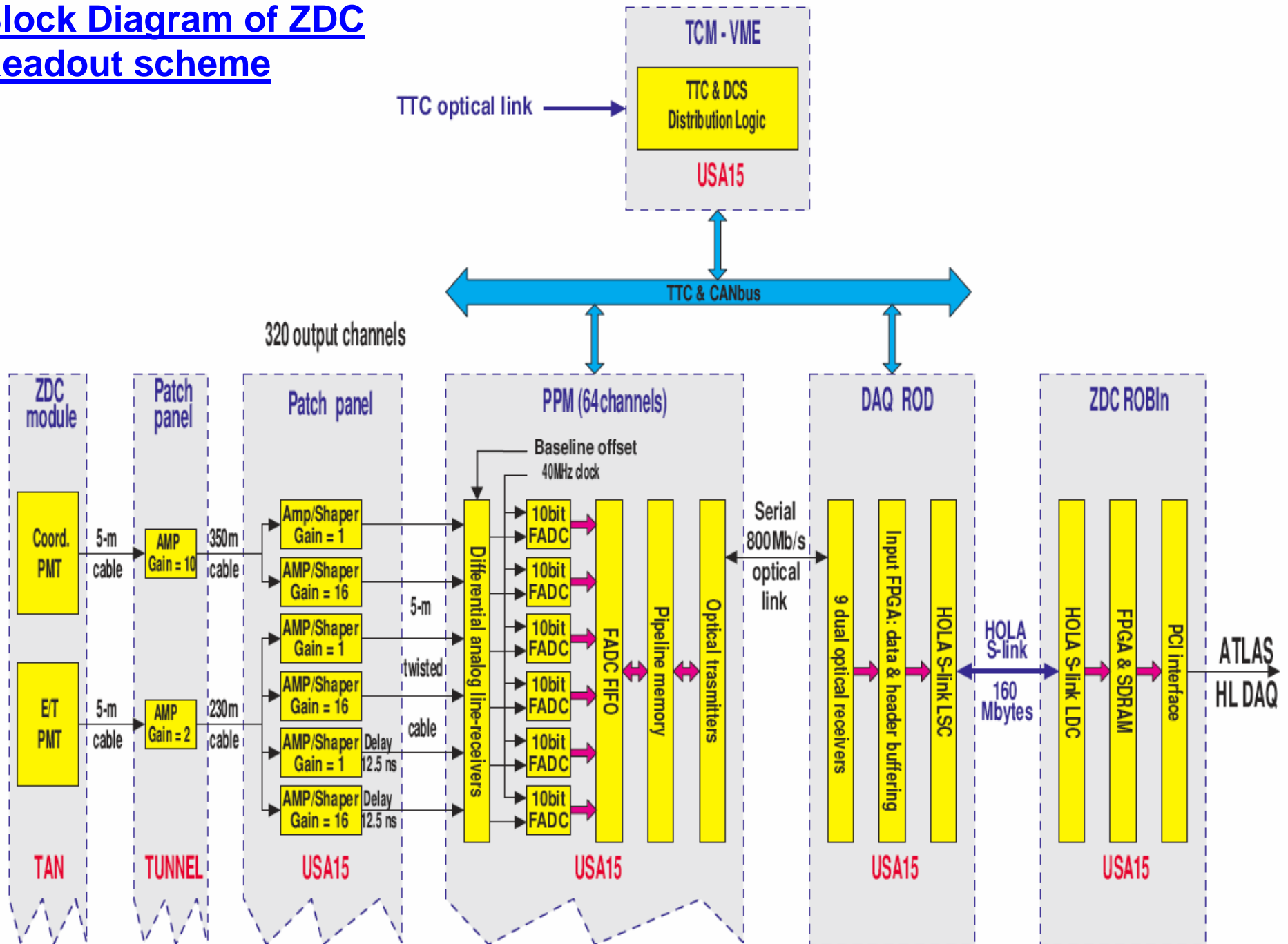

ZDC L1 trigger

- The ZDC trigger will be used primarily as a 2-arm coincidence (each arm above a preset threshold) in Heavy ion runs
- Trigger bits assigned in Central trigger Processor
- CTP is designed to accept calibration triggers as well as trigger from small systems like the ZDC

ZDC time, space and energy resolution (Average over active area)

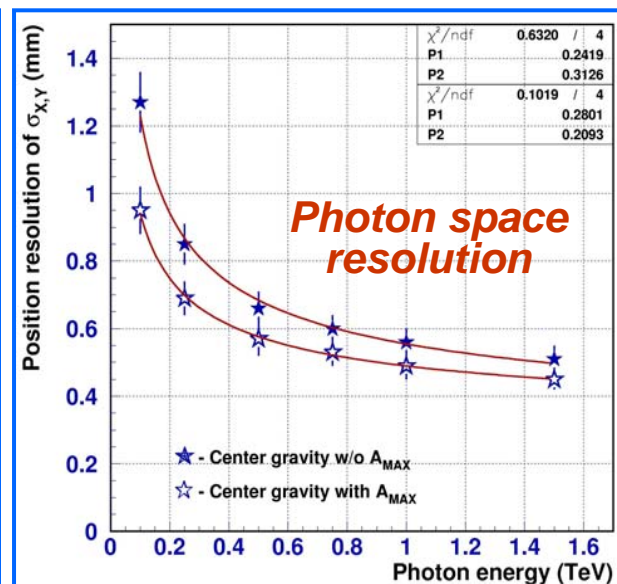
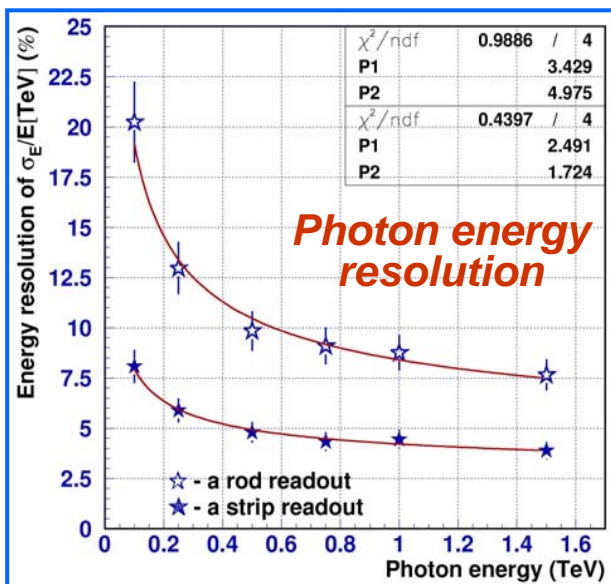
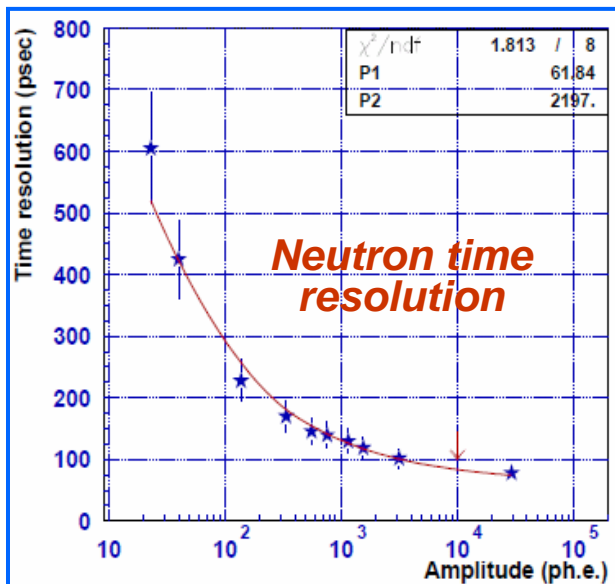
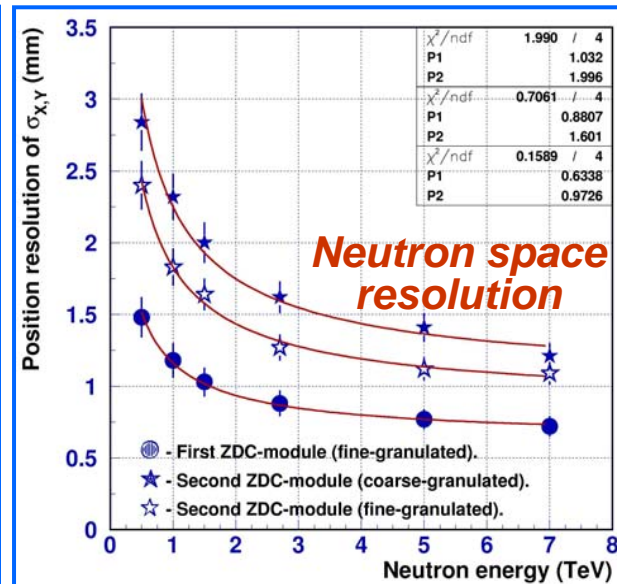
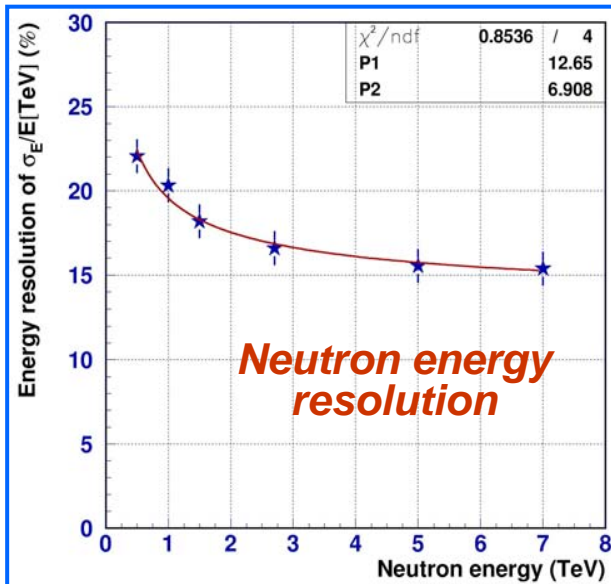
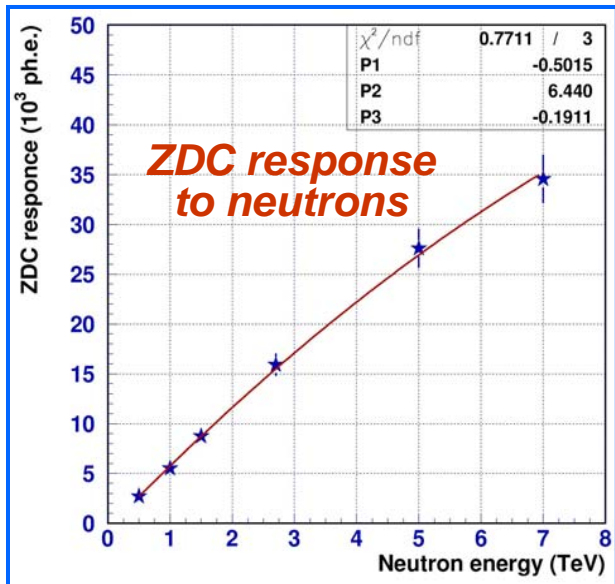

Background (PYTHIA / GEANT simulation)

Photons in ZDC per pp interaction

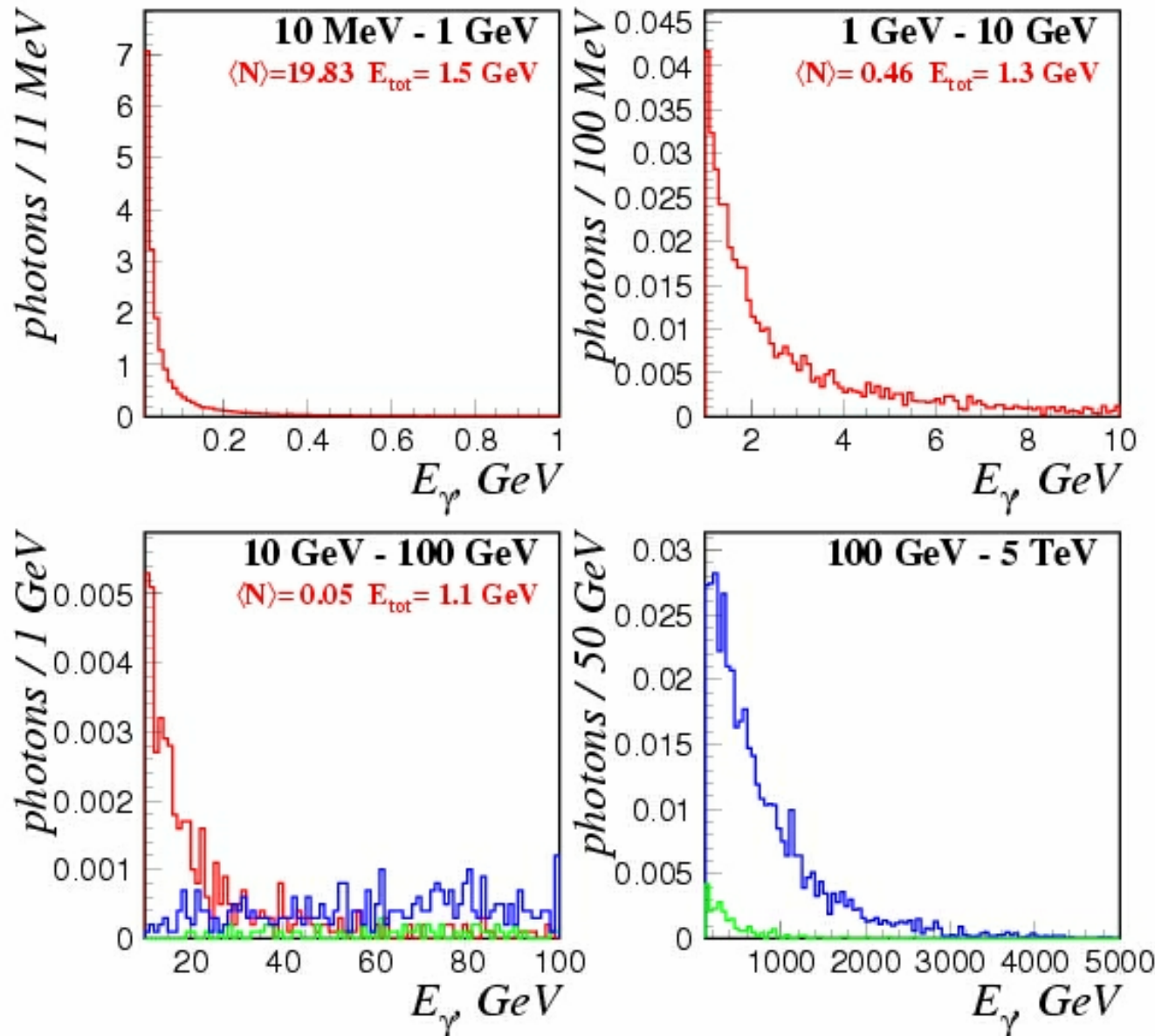

Sources of signal and Background

Interaction Point

Decays in Flight

“Walls”

Background (PYTHIA / GEANT simulation)

Neutrons in ZDC per pp interaction

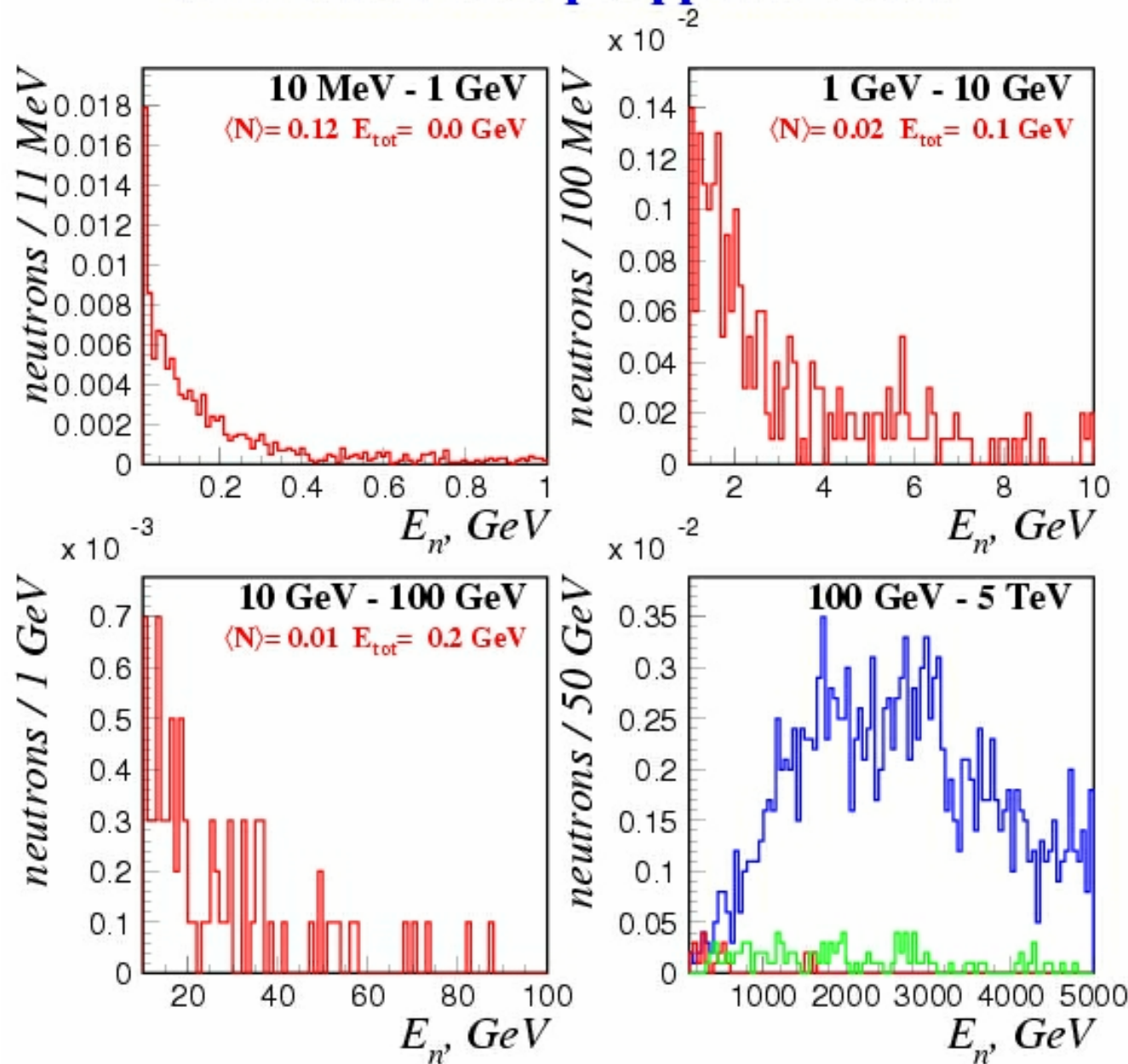

Sources of Signal and Background

- Interaction Point
- Decays in Flight
- "Walls"

Absorbed dose (rad/yr) in TAN at luminosity $10^{33} \text{ cm}^{-2}\text{sec}^{-1}$

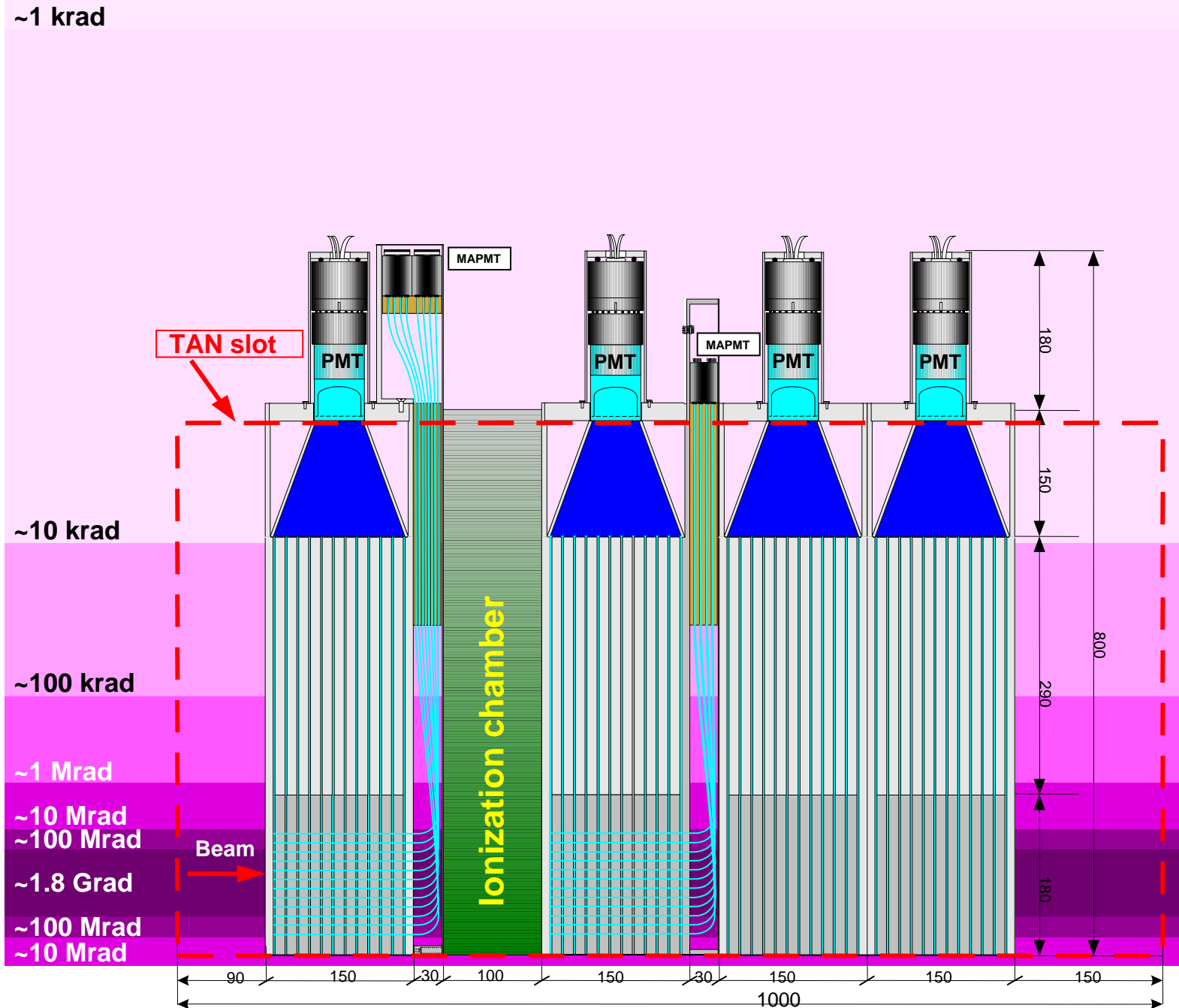

We exposed quartz rods at the BNL linac Isotope Producer facility

At 5 Grad absorbed dose, light loss corresponds to a 30% deterioration in resolution of coordinate measurer

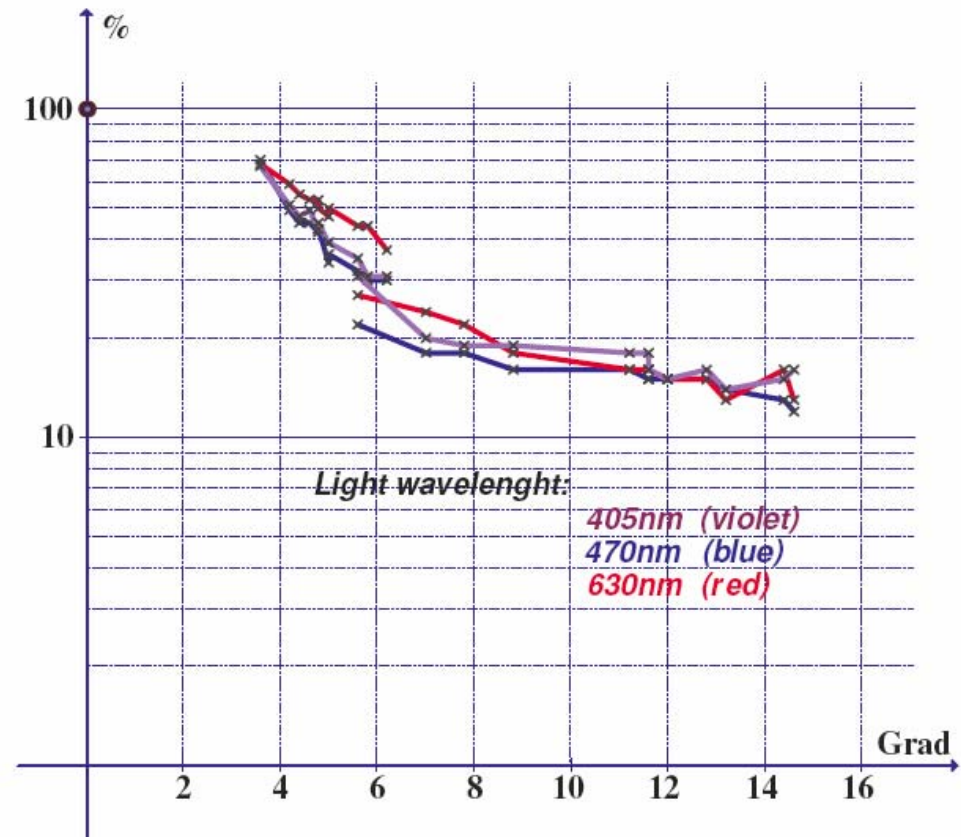

Test beam exposure in SPS North area parasitic with RP (Oct. '06)

Single module exposed to 230 GeV proton beam

Spectra with 0, 10 and 20 cm steel blocks inserted in the beam

Comparison to simulation (note same energy scale used in all Simulations)

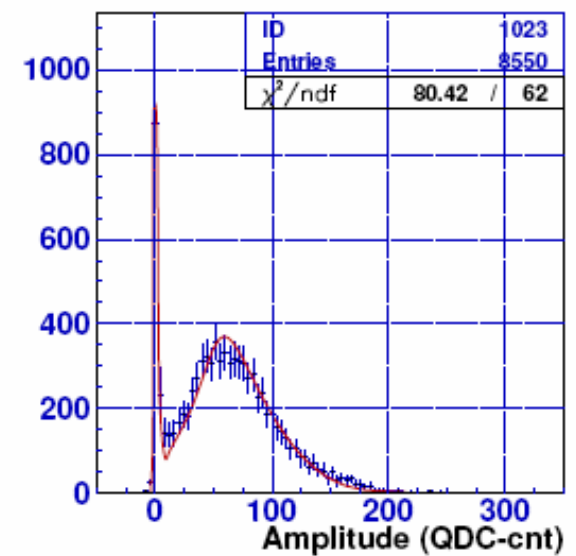
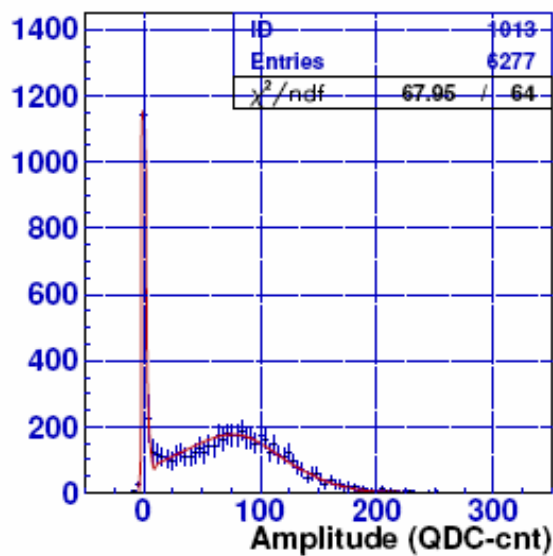
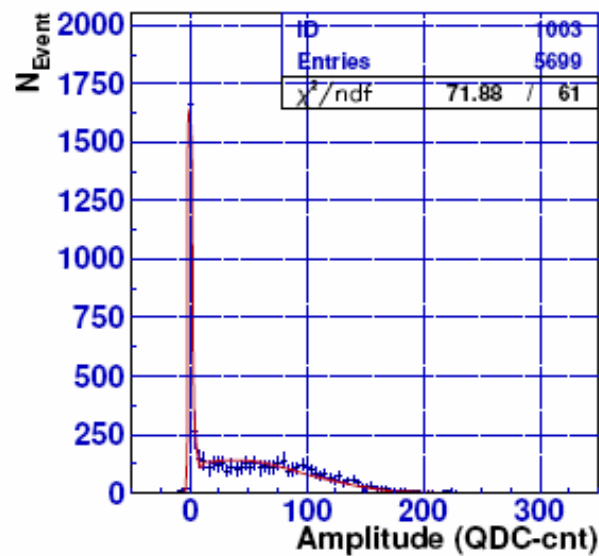

Beam tuned to enrich positron component.
Peak used to confirm light yield and agreement
With simulations

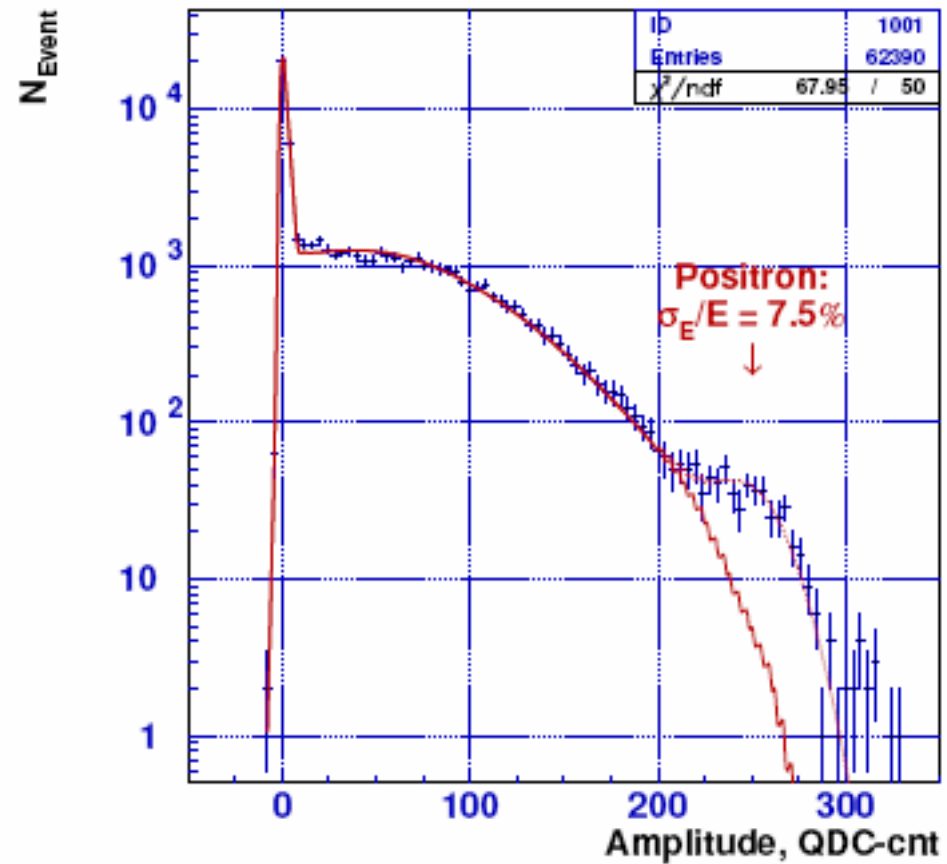

Summary of cables to USA15

	cable use	cable type	no. of cables	length(m)
Already installed	fast trigger signals	C-50-6-1 50 Ω	4	230
	fast signals to WFD's	C-50-3-1 50 Ω	6	230
	coordinate readout	C-50-3-1 50 Ω	24	350
	extra coordinate readout (1 side)	C-50-3-1 50 Ω	24	350
	test signal	C-50-3-1 50 Ω	2	350
	PMT HV cable	RG 59 equiv	6	350
	extra HV (1-side)	RG 59 equiv	7	350
	low voltage	power cable	2	350
	EM coordinate readout (1 side)	C-50-3-1 50 Ω	96	350

Risetime of fast signals $\tau_r = 5$ nsec
 Attenuation 50%

What we are planning

- Install full (8 module) ZDC phased with the LHCf run plan
- Integrate ZDC into ATLAS DAQ and provide a level1 trigger
- Will remove ZDC for highest Luminosity pp runs
- Provide a critical role in Heavy Ion program
- Important measurements of forward particle production in pp collisions over full acceptance permitted by TAN constraints
- Funding from US Nuclear Physics program

Schedule

- 1st module completed and tested in beam-no design changes planned
- Construction of mechanical modules can begin 2/07 expect completion in 6/07
- Remaining cables installed this spring
- Main schedule uncertainty is window for installation of cables and modules
- Operation possible at end of '07 in conjunction with LCHf detector

Extra slides

Tested correlation between coordinate measurement and
Position of 2 mm high beam scintillation counters

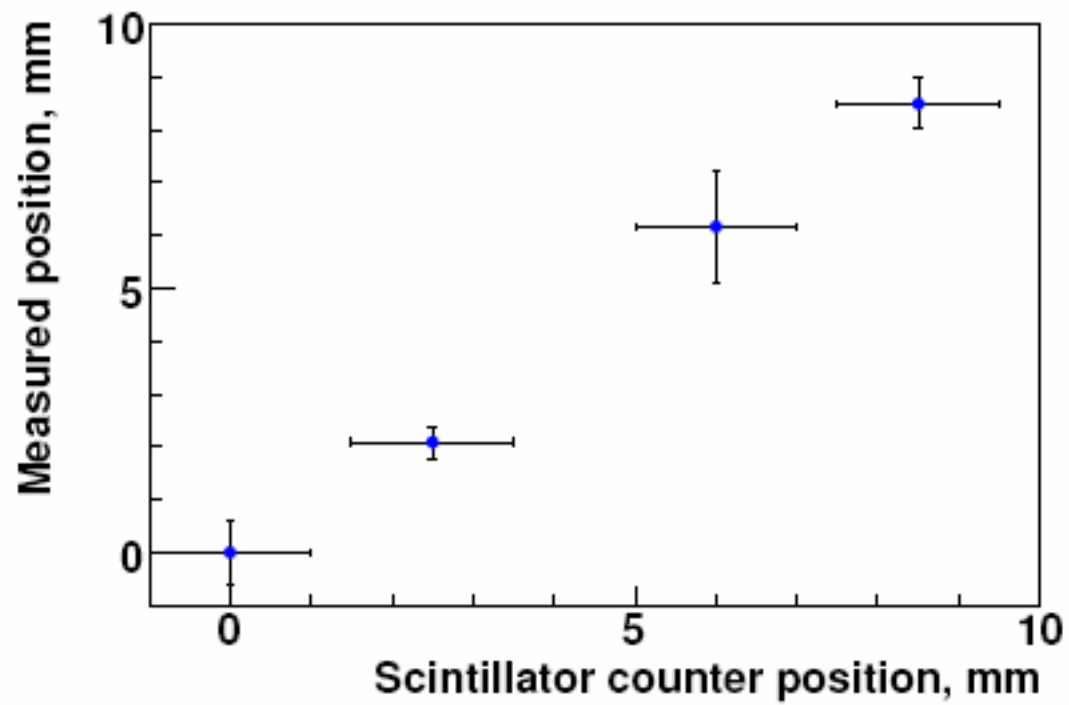

Simulation of kinematic acceptance

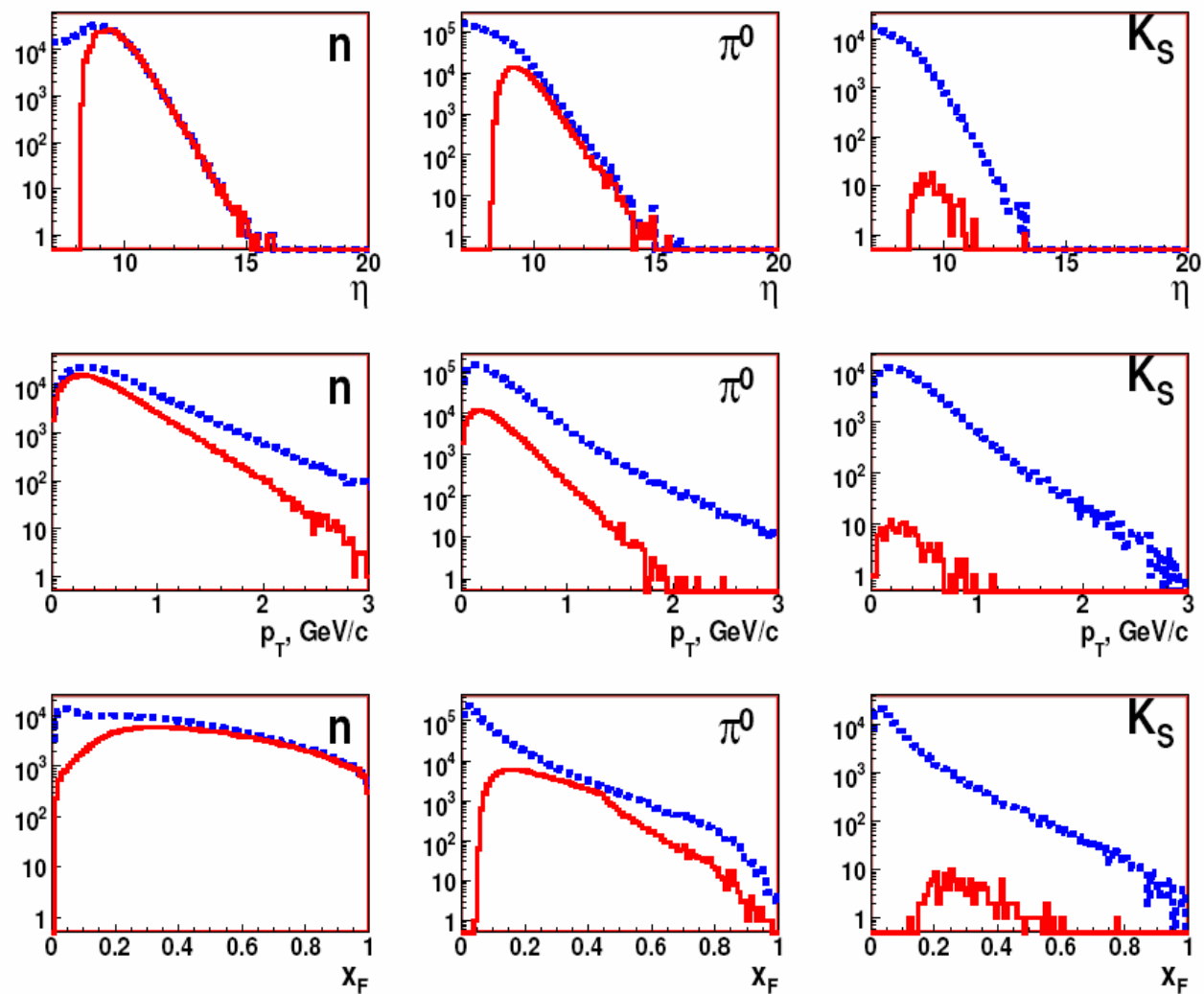

Energy resolution for Photons and neutrons (GEANT simulation)

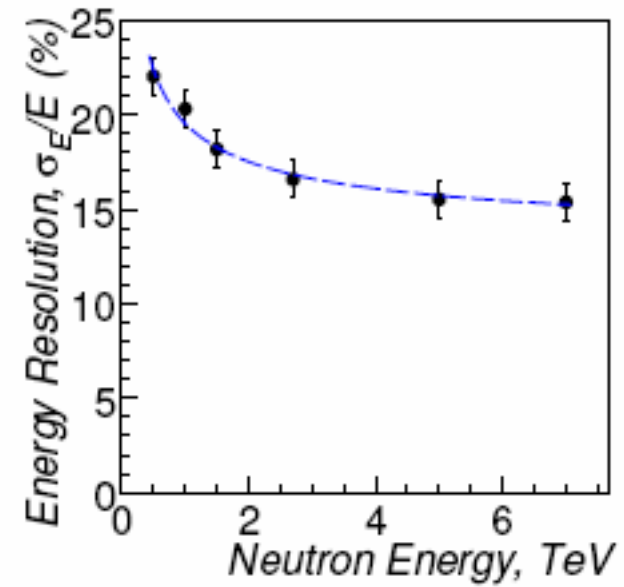
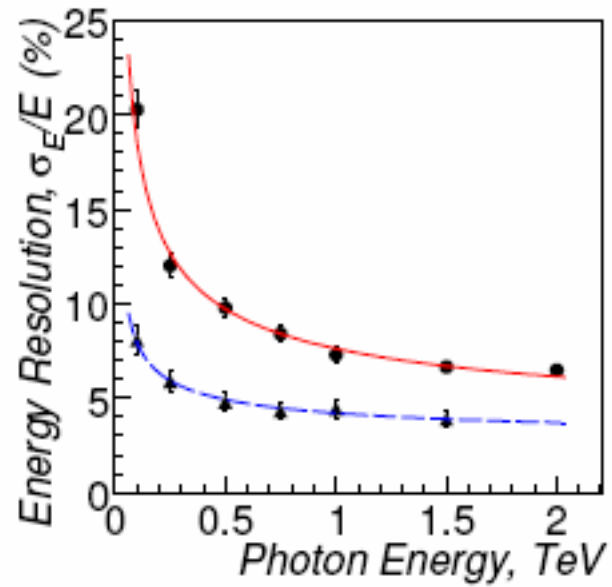

Coordinate resolution for photons and neutrons

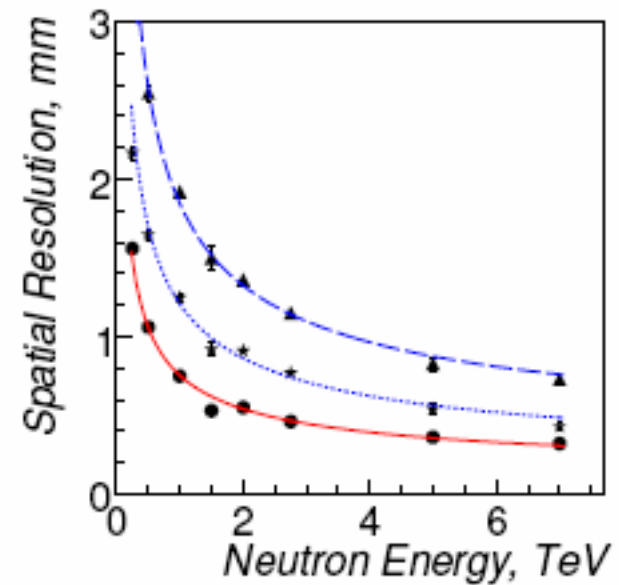
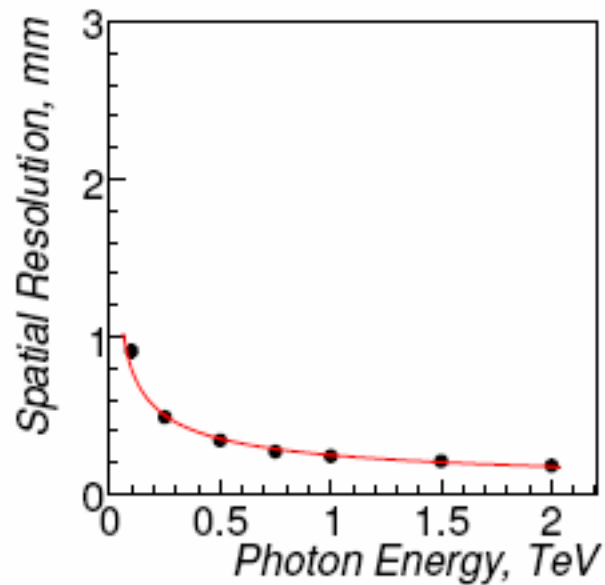

L1 Calo boards

- We require 5 PreProcessor modules
- Current production is for 180 modules of which 120 modules needed for L1calo system (KarlHeinz Meier, Heidelberg)
- Project would be charged for cost of materials (~10k euro/module)
- 1 ROD sufficient

Phasing with LHCf run

Phase I

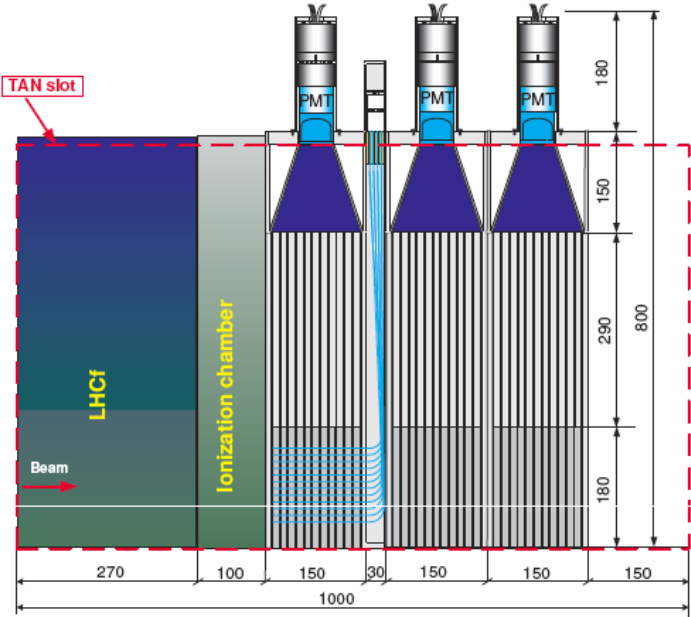

Phase II

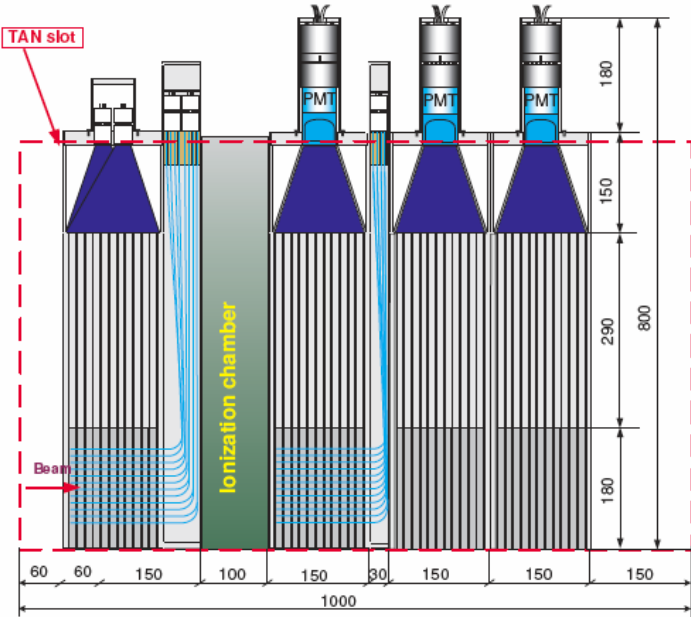

For transport the signals from ZDC modules to USA15 room we are using two type of coaxial cables:

1. the fast C-50-6-1 cable for stripe readout and
2. the cheap C-50-3-1 cable for X/Y readout.

I used the coaxial cable (type RG 58C/U) what have close to C-50-3-1 characteristics (see Fig.1) for measurement the attenuation and shapes of signals from PMT versus the length of cable (see Fig2).

I show the expected values for fast C-50-6-1 cable in Fig.3 (I'm sure about the attenuation curve, but about fall and rise time need additional research).

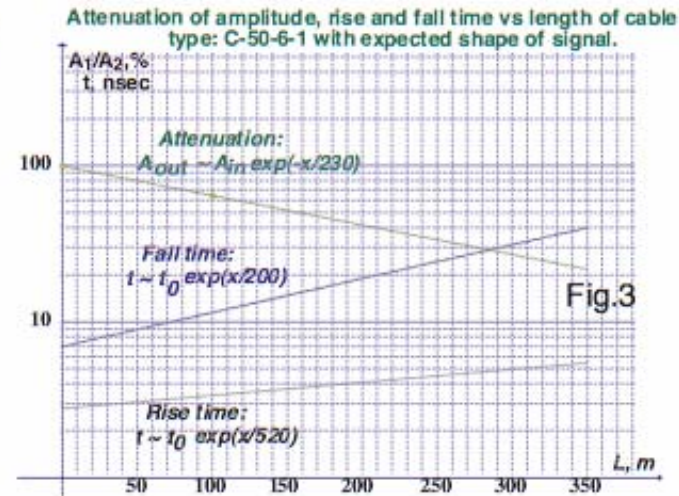
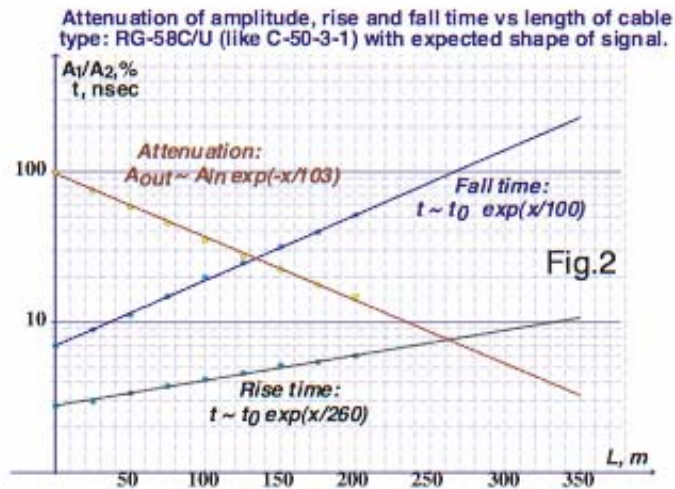
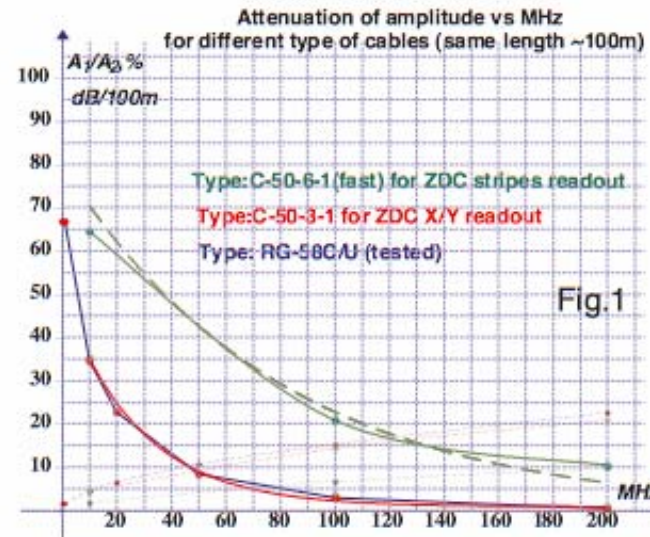

ZDC Project file (p.1) including Phase II eqpt and labor costs

ID	WBS	Task Name	Duration	Start	Finish	Pred'sor	Cost	Contingency Cost	Base Cost + Contingency Cost	2006												2007											
										D	J	F	M	A	M	J	J	A	S	O	N	D	J	F	M	A	M	J	J	A	S	O	N
1	1	Project Summary	372 days	Fri 1/6/06	Mon 7/2/07		\$381,066.88	\$64,847.29	\$445,914.17	[Summary bar]																							
2	1.1	Project Start	0 days	Fri 1/6/06	Fri 1/6/06		\$0.00	\$0.00	\$0.00	[Milestone diamond]																							
3	1.2	ZDC Prototype	232.25 days	Fri 1/6/06	Mon 12/11/06		\$44,211.04	\$7,429.12	\$51,640.16	[Summary bar]																							
4	1.2.1	Prototype Design	52 days	Fri 1/6/06	Thu 3/23/06		\$0.00	\$0.00	\$0.00	[Summary bar]																							
5	1.2.1.1	Conceptual Design	49 days	Fri 1/6/06	Mon 3/20/06		\$0.00	\$0.00	\$0.00	[Summary bar]																							
6	1.2.1.1.1	Development (simulation, sketching, material	48 days	Fri 1/6/06	Fri 3/17/06	2	\$0.00	\$0.00	\$0.00	[Summary bar]																							
7	1.2.1.1.2	Final Design Review	1 day	Fri 3/17/06	Mon 3/20/06	6	\$0.00	\$0.00	\$0.00	[Summary bar]																							
8	1.2.1.2	Technical Design	3 days	Mon 3/20/06	Thu 3/23/06		\$0.00	\$0.00	\$0.00	[Summary bar]																							
9	1.2.1.2.1	Development (technical drawings)	2 days	Mon 3/20/06	Wed 3/22/06	7	\$0.00	\$0.00	\$0.00	[Summary bar]																							
10	1.2.1.2.2	Final Design Review	1 day	Wed 3/22/06	Thu 3/23/06	9	\$0.00	\$0.00	\$0.00	[Summary bar]																							
11	1.2.2	Prototype Production	121.25 days	Thu 3/23/06	Thu 9/14/06		\$42,443.04	\$7,075.52	\$49,518.56	[Summary bar]																							
12	1.2.2.1	Module production	71.25 days	Thu 5/18/06	Wed 8/30/06		\$18,764.00	\$3,752.80	\$22,516.80	[Summary bar]																							
13	1.2.2.1.1	Fabrication/Procurement	70 days	Thu 5/18/06	Tue 8/29/06	10FS+40 c	\$17,924.00	\$3,584.80	\$21,508.80	[Summary bar]																							
14	1.2.2.1.2	Delivery/Test	1.25 days	Tue 8/29/06	Wed 8/30/06	13	\$840.00	\$168.00	\$1,008.00	[Summary bar]																							
15	1.2.2.2	Quartz-optic production (for strips)	34.05 days	Thu 6/1/06	Fri 7/21/06		\$2,838.60	\$340.63	\$3,179.23	[Summary bar]																							
16	1.2.2.2.1	Fabrication/Procurement	30 days	Thu 6/1/06	Mon 7/17/06	10FS+49 c	\$441.00	\$52.92	\$493.92	[Summary bar]																							
17	1.2.2.2.2	Delivery/Test	4.05 days	Mon 7/17/06	Fri 7/21/06	16	\$2,397.60	\$287.71	\$2,685.31	[Summary bar]																							
18	1.2.2.3	Quartz-optic production (for rods)	31.2 days	Thu 6/1/06	Tue 7/18/06		\$1,223.04	\$146.76	\$1,369.80	[Summary bar]																							
19	1.2.2.3.1	Fabrication/Procurement	30 days	Thu 6/1/06	Mon 7/17/06	10FS+49 c	\$560.64	\$67.28	\$627.92	[Summary bar]																							
20	1.2.2.3.2	Delivery/Test	1.2 days	Mon 7/17/06	Tue 7/18/06	19	\$662.40	\$79.49	\$741.89	[Summary bar]																							
21	1.2.2.4	Guide-optic production (for a strip's readout)	30.13 days	Thu 6/1/06	Mon 7/17/06		\$1,091.00	\$218.20	\$1,309.20	[Summary bar]																							
22	1.2.2.4.1	Fabrication/Procurement	30 days	Thu 6/1/06	Mon 7/17/06	10FS+49 c	\$977.00	\$195.40	\$1,172.40	[Summary bar]																							
23	1.2.2.4.2	Delivery/Test	0.13 days	Mon 7/17/06	Mon 7/17/06	22	\$114.00	\$22.80	\$136.80	[Summary bar]																							
24	1.2.2.5	Module instrumentation (strip's photodetector)	45 days	Thu 6/1/06	Mon 8/7/06		\$2,544.00	\$332.64	\$2,876.64	[Summary bar]																							
25	1.2.2.5.1	Fabrication/Procurement of PMT-XP3282B	39 days	Thu 6/1/06	Fri 7/28/06	10FS+49 c	\$1,950.00	\$234.00	\$2,184.00	[Summary bar]																							
26	1.2.2.5.2	Fabrication/Procurement of a PMT base (VD)	5 days	Fri 7/28/06	Fri 8/4/06	25	\$262.00	\$30.24	\$292.24	[Summary bar]																							
27	1.2.2.5.3	Delivery/Test (PMT&Base)	0.38 days	Fri 8/4/06	Mon 8/7/06	26	\$342.00	\$68.40	\$410.40	[Summary bar]																							
28	1.2.2.6	Module instrumentation (rod's photodetectors)	90 days	Thu 3/23/06	Tue 8/1/06		\$15,014.40	\$2,090.88	\$17,105.28	[Summary bar]																							
29	1.2.2.6.1	Fabrication/Procurement of PMT-R7800-06-l	20 days	Thu 3/23/06	Thu 4/20/06	10	\$9,000.00	\$1,080.00	\$10,080.00	[Summary bar]																							
30	1.2.2.6.2	Fabrication/Procurement of a PMT base ???	39 days	Thu 4/20/06	Thu 6/15/06	29	\$2,400.00	\$288.00	\$2,688.00	[Summary bar]																							
31	1.2.2.6.3	Delivery/Test (PMT&Base)	0.75 days	Thu 6/15/06	Thu 6/22/06	30	\$504.00	\$100.80	\$604.80	[Summary bar]																							
32	1.2.2.6.4	Fabrication/Procurement (Preamp& Analog-s	11 days	Thu 6/22/06	Tue 7/11/06	31	\$2,400.00	\$480.00	\$2,880.00	[Summary bar]																							
33	1.2.2.6.5	Delivery/Test (Preamp& Analog-sum)	1.2 days	Tue 7/11/06	Tue 8/1/06	32	\$710.40	\$142.08	\$852.48	[Summary bar]																							
34	1.2.2.7	Module Assembling & Lab. Test	10 days	Wed 8/30/06	Thu 9/14/06		\$968.00	\$193.60	\$1,161.60	[Summary bar]																							
35	1.2.2.7.1	Assembling	7 days	Wed 8/30/06	Mon 9/11/06	14	\$840.00	\$168.00	\$1,008.00	[Summary bar]																							
36	1.2.2.7.2	Optical Test	3 days	Mon 9/11/06	Thu 9/14/06	35	\$128.00	\$25.60	\$153.60	[Summary bar]																							
37	1.2.3	Beam Test & Study	59 days	Thu 9/14/06	Mon 12/11/06		\$1,768.00	\$353.60	\$2,121.60	[Summary bar]																							
38	1.2.3.1	Shipping	1.5 days	Thu 9/14/06	Thu 10/5/06	36	\$1,768.00	\$353.60	\$2,121.60	[Summary bar]																							
39	1.2.3.2	Beam test	19 days	Thu 10/12/06	Wed 11/8/06	38FS+5 de	\$0.00	\$0.00	\$0.00	[Summary bar]																							
40	1.2.3.3	Data analysis	20 days	Wed 11/8/06	Mon 12/11/06	39	\$0.00	\$0.00	\$0.00	[Summary bar]																							
41	1.3	ZDC detector	96.5 days	Mon 12/11/06	Tue 5/1/07		\$158,725.64	\$28,697.75	\$187,423.39	[Summary bar]																							
42	1.3.1	ZDC Design	11 days	Mon 12/11/06	Wed 12/27/06		\$0.00	\$0.00	\$0.00	[Summary bar]																							
43	1.3.1.1	Conceptual Design	4 days	Mon 12/11/06	Fri 12/15/06		\$0.00	\$0.00	\$0.00	[Summary bar]																							
44	1.3.1.1.1	Development (simulation, sketching, material	3 days	Mon 12/11/06	Thu 12/14/06	40	\$0.00	\$0.00	\$0.00	[Summary bar]																							
45	1.3.1.1.2	Final Design Review	1 day	Thu 12/14/06	Fri 12/15/06	44	\$0.00	\$0.00	\$0.00	[Summary bar]																							
46	1.3.1.2	Technical Design	7 days	Fri 12/15/06	Wed 12/27/06		\$0.00	\$0.00	\$0.00	[Summary bar]																							
47	1.3.1.2.1	Development (technical drawings)	3 days	Fri 12/15/06	Wed 12/20/06	45	\$0.00	\$0.00	\$0.00	[Summary bar]																							
48	1.3.1.2.2	Final Design Review	4 days	Wed 12/20/06	Wed 12/27/06	47	\$0.00	\$0.00	\$0.00	[Summary bar]																							
49	1.3.2	ZDC Production	92.5 days	Fri 12/15/06	Tue 5/1/07		\$158,725.64	\$28,697.75	\$187,423.39	[Summary bar]																							
50	1.3.2.1	Module production	73.75 days	Wed 12/27/06	Fri 4/13/07		\$101,808.00	\$20,361.60	\$122,169.60	[Summary bar]																							

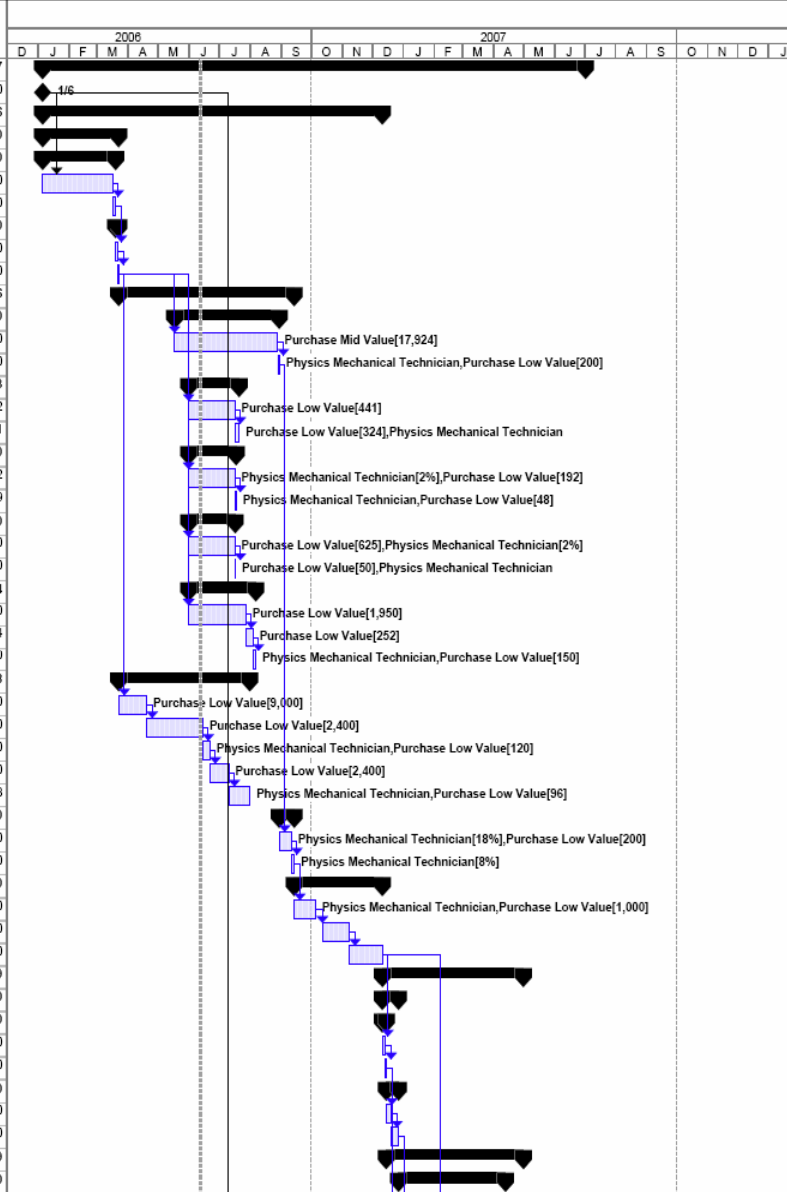

Project: ZDC June 12 2006
Date: Mon 8/12/06

Task		Progress		Summary		External Tasks		Deadline	
Split		Milestone		Project Summary		External Milestone			

Concept for remote module replacement

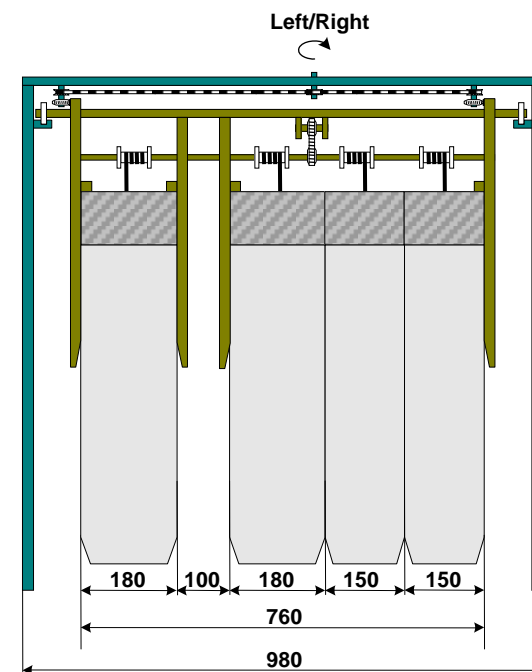
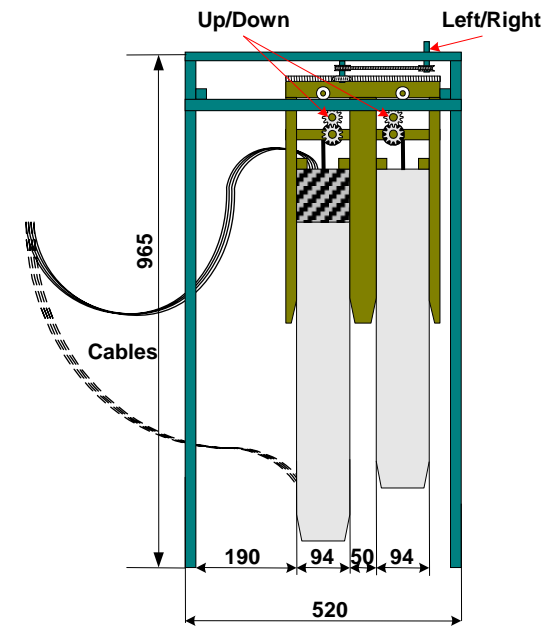
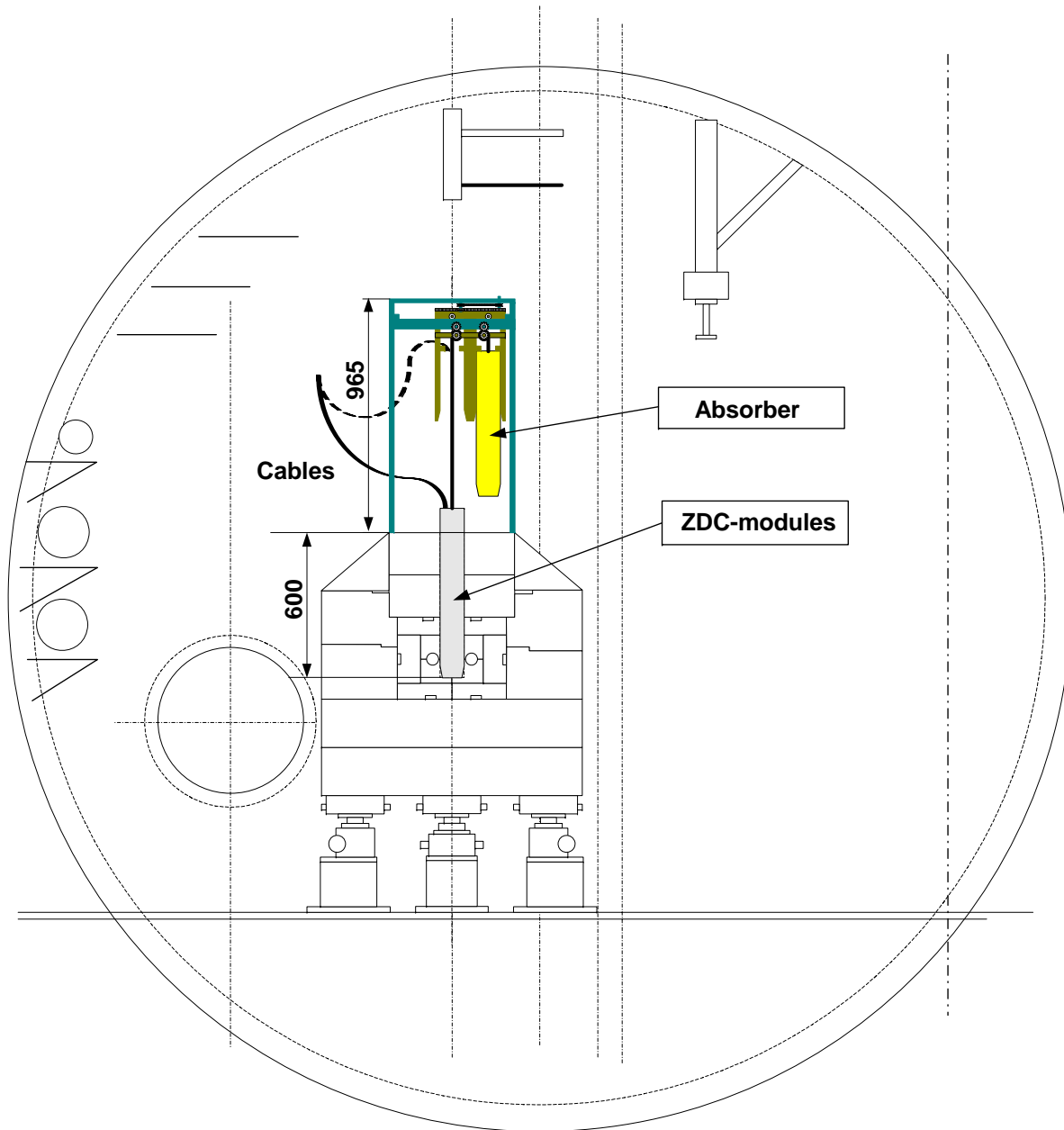

Background

MARS15:Radiation in TAN, LHCf & ZDC – N.Mokhov

TAN Integration – CERN, Mar.10, 2006

SOURCE TERM AT TAN at $-5.5 < x, y < 5.5$ cm

	FROM IP		NON-IP		TOTAL	
	<N>	<E> (GeV)	<N>	<E> (GeV)	<N>	<E> (GeV)
p	7.8106E-06	1.3928E+03	7.3854E-02	1.5650E+02	7.3862E-02	1.5663E+02
n	1.8278E-01	2.9556E+03	3.0651E-01	1.0426E+02	4.8929E-01	1.1694E+03
π^+	3.9053E-05	1.4448E+03	1.8044E-01	2.6252E+01	1.8048E-01	2.6559E+01
π^-	1.2583E-03	2.5358E+03	2.0158E-01	3.3929E+01	2.0284E-01	4.9450E+01
K^+	3.9053E-05	1.5920E+03	1.3593E-02	1.8641E+01	1.3632E-02	2.3149E+01
K^-	1.8779E-04	2.6675E+03	1.1495E-02	1.4602E+01	1.1683E-02	5.7245E+01
μ^+	0.0000E+00	0.0000E+00	3.3441E-04	6.3382E+00	3.3441E-04	6.3382E+00
μ^-	0.0000E+00	0.0000E+00	7.6302E-04	9.9281E+00	7.6302E-04	9.9281E+00
γ	6.4190E+00	7.9219E+01	8.9348E+01	1.9997E-01	9.5767E+01	5.4964E+00
e^+	2.3936E-01	3.3844E-01	5.9039E+00	1.5220E-01	6.1432E+00	1.5946E-01
e^-	9.6830E-02	1.2591E+00	5.7887E+00	1.6300E-01	5.8856E+00	1.8103E-01
pbar	1.4059E-04	2.8715E+03	5.1247E-03	9.8705E+01	5.2652E-03	1.7274E+02
K_L^0	3.6506E-02	1.2308E+03	1.2349E-02	2.6881E+01	4.8855E-02	9.2650E+02
K_S^0	4.8158E-03	2.2434E+03	2.1740E-04	4.7451E+01	5.0332E-03	2.1485E+03
Λ	2.2313E-02	3.5788E+03	0.0000E+00	0.0000E+00	2.2313E-02	3.5788E+03
Λ bar	6.3297E-04	1.8356E+03	0.0000E+00	0.0000E+00	6.3297E-04	1.8356E+03
Σ^-	1.5640E-05	2.3074E+03	0.0000E+00	0.0000E+00	1.5640E-05	2.3074E+03
nbar	1.2447E-02	1.1503E+03	6.2474E-03	1.7173E+02	1.8694E-02	8.2330E+02

$P(W/10^3) = 154$

10

164

ZDC cable detail

ZDC Arm#1

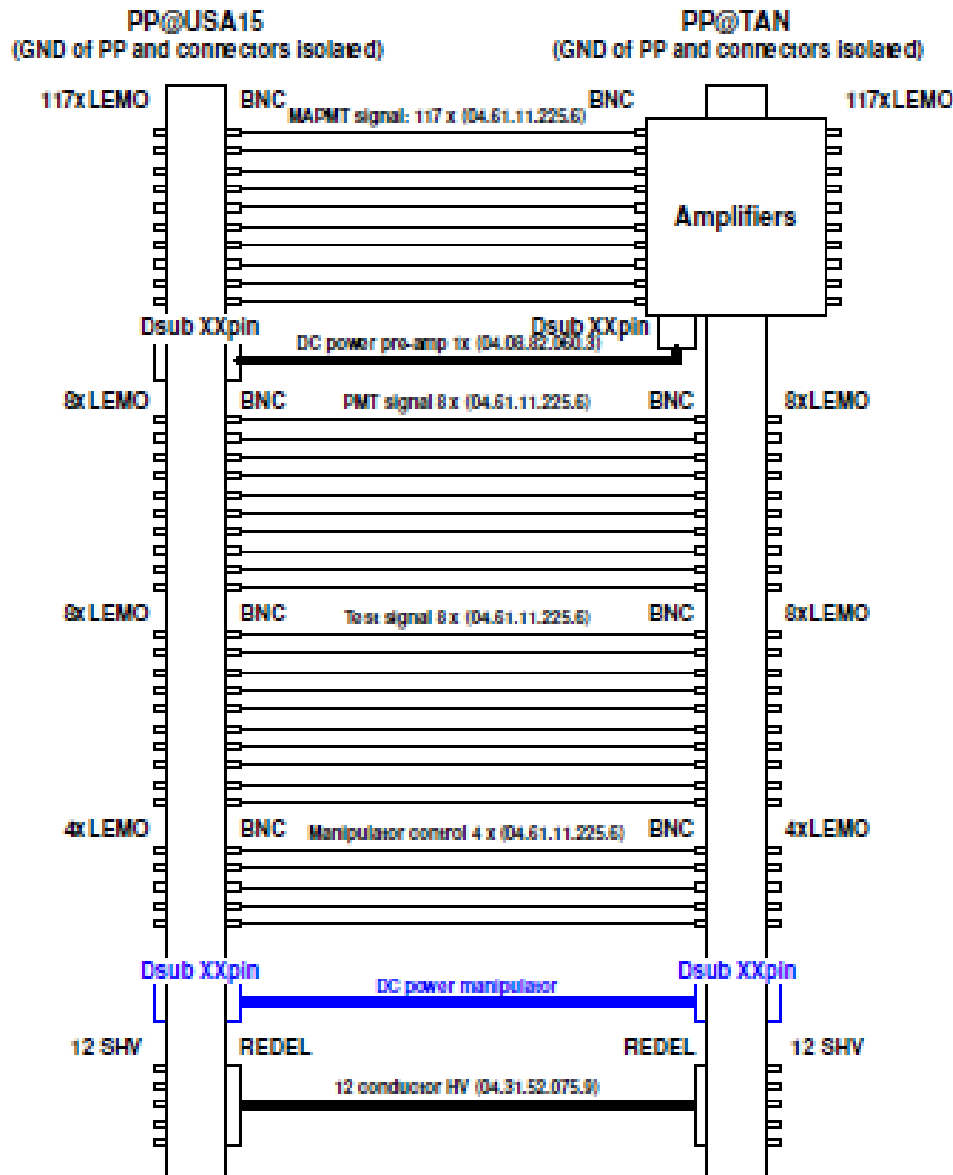

ZDC Arm#2

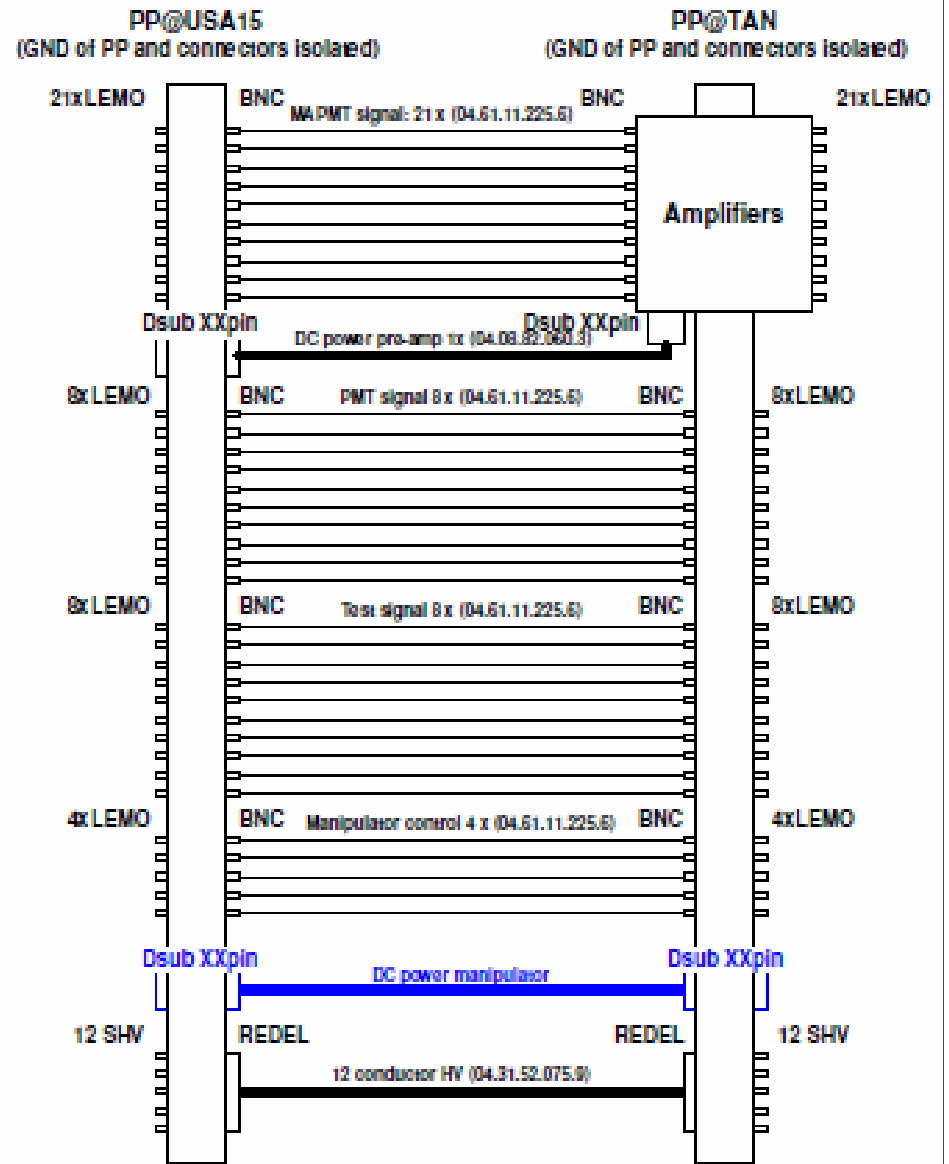

X-Y rod holder

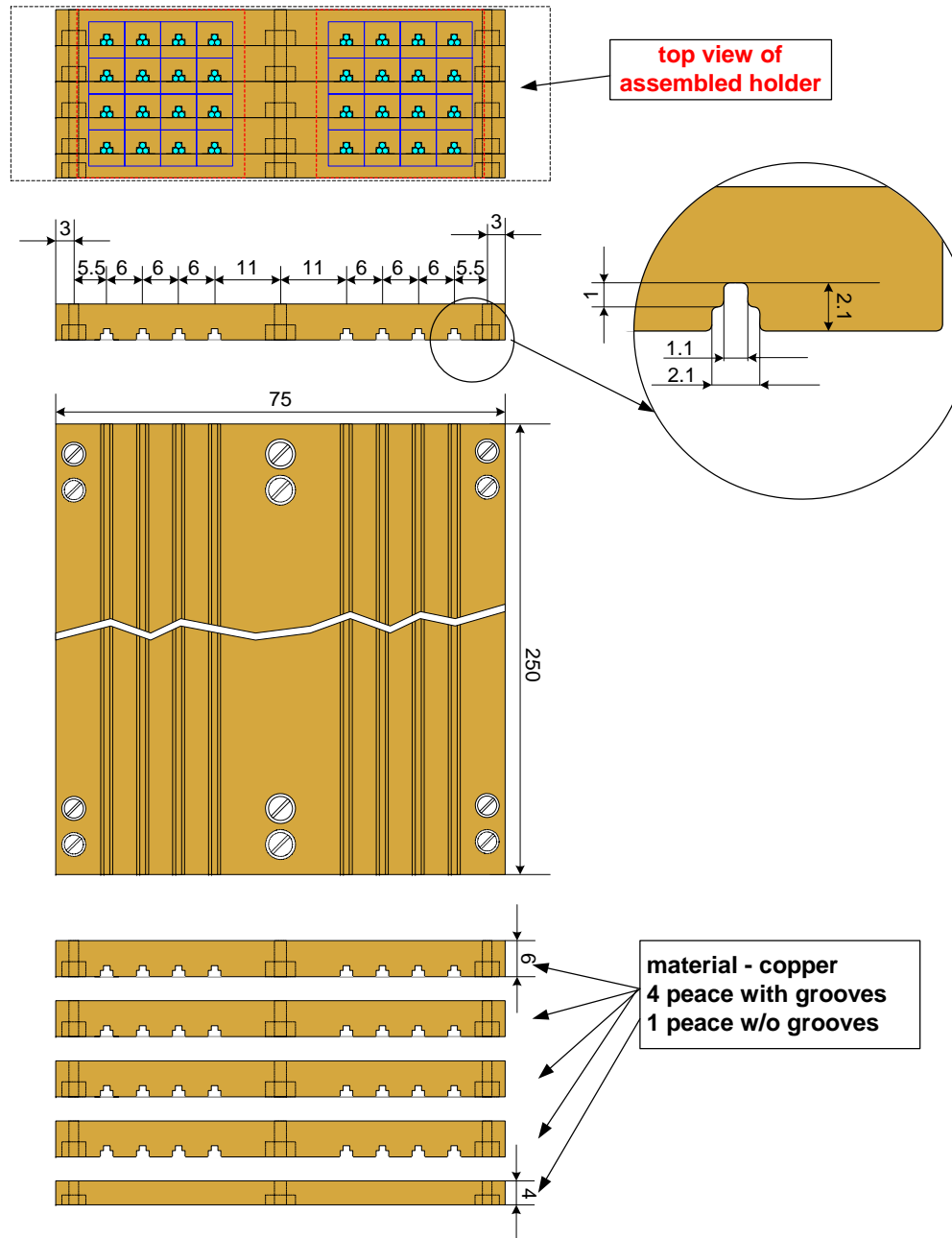

Assembling module: installing X-Y rods

Bare module

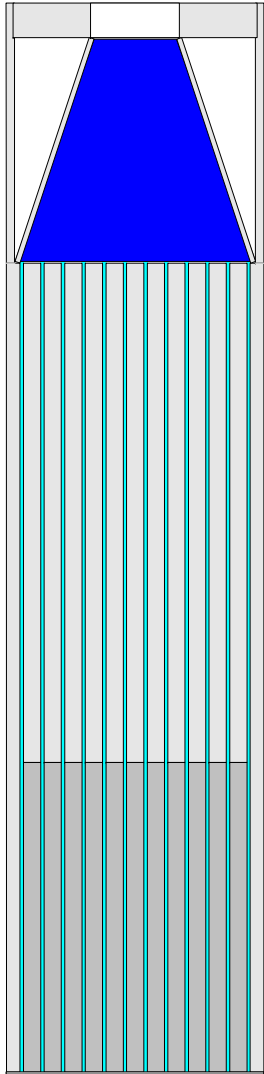

Rod is put in module and measured

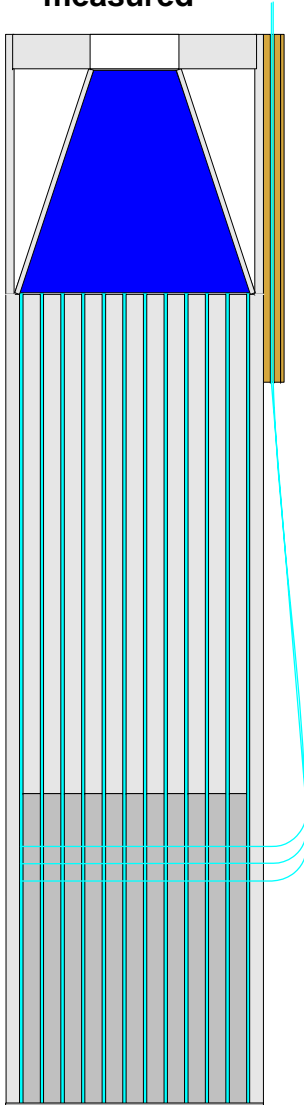

Rod is removed, cut to size and replaced

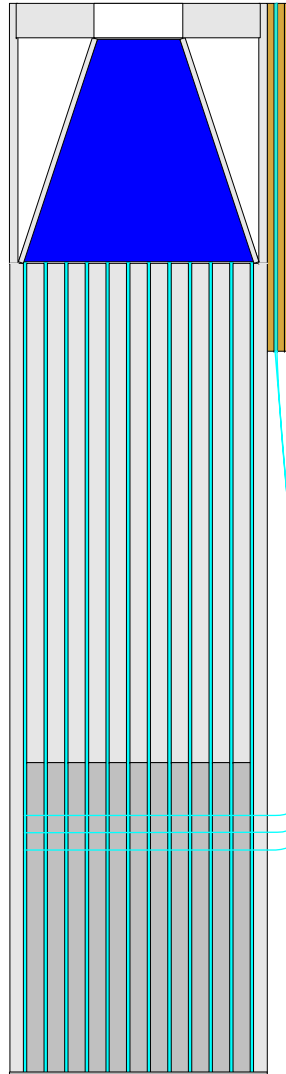

Rod is put in module and measured

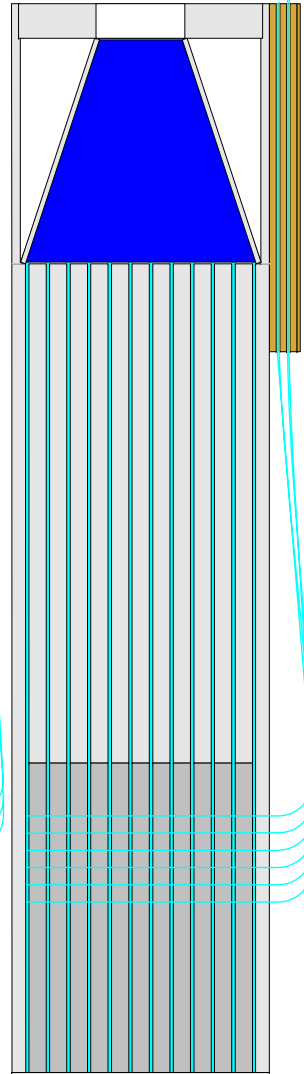

Rod is removed, cut to size and replaced

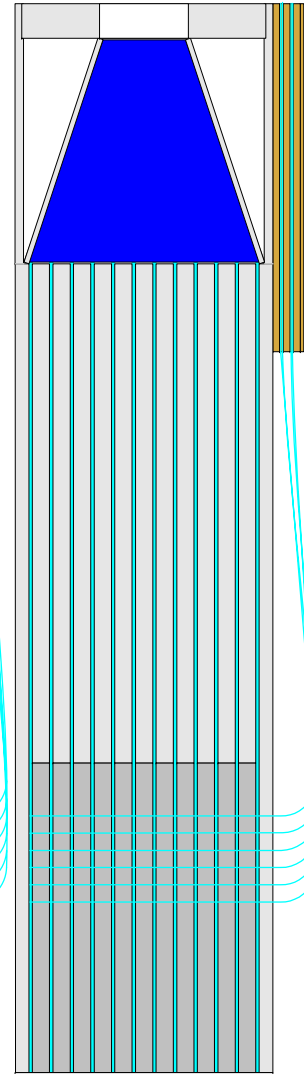

All rods installed

