

# A Journey from the Infinitely Big to the Infinitely Small

*Cristiano Alpigiani*



- Conference will start shortly
- Switch off camera and microphone
- Open the *chat* tool (down-right)

# Your Virtual Conference

## Format

- Presentation (~45 minutes in total)
- Questions and answers (20 minutes in total)
- But please ask questions also during it!

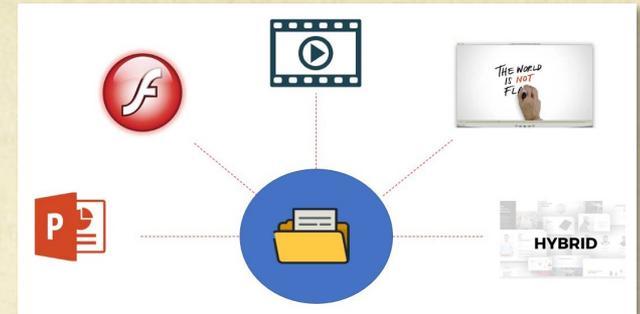

## During presentation

- Ask questions using the chat
- Use microphone or camera only if needed



## After presentation

- Please fill out survey on Indico page
- Material and links available on Indico page



**The conference is a general presentation about CERN, its organization, the research, people behind the scenes, etc. All scheduled conferences will have the same format**

# I am...

- A **particle physicist** working in the ATLAS experiment
- I am looking for Physics Beyond the Standard Model (mainly **long-lived particles**)
- I am searching for particles from the **Dark/Hidden Sector**

ATLAS

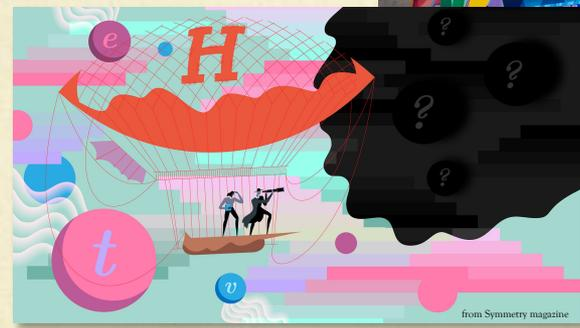

MATHUSLA

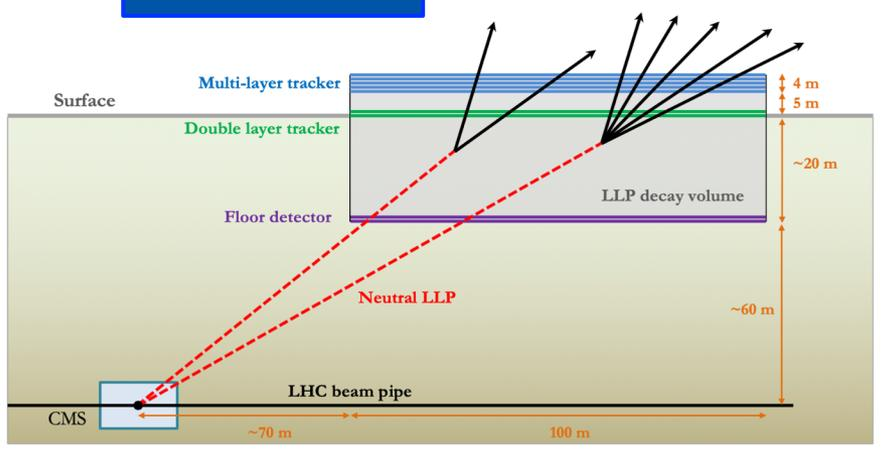

- I am also working on a proposal for a future (big) experiment searching for **very long-lived particles** and **cosmic rays**

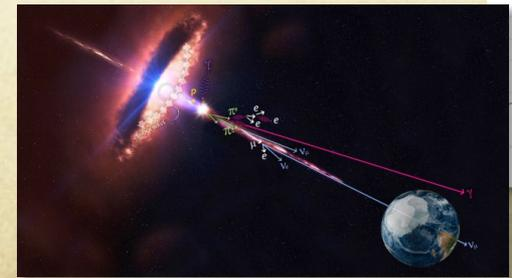
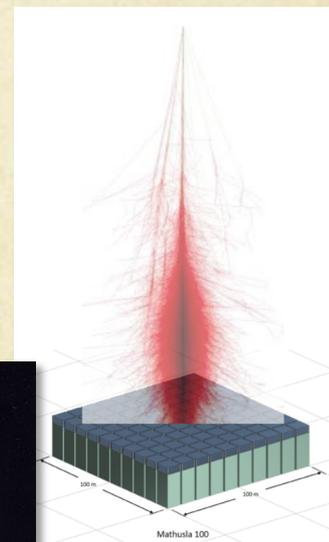

# CERN

---

Conseil  
Européen pour la  
Recherche  
Nucléaire

1953

Organisation  
Européenne pour la  
Recherche  
Nucléaire

1954

# 23 Member States

## Budget (2020)

- ~1.2 billion CHF
- ~1.1 miliardi EUR
- ~1.0 billion GBP
- ~1.2 billion USD



 Austria (1959)	 Sweden (1953)	
 Belgium (1953)	 Switzerland (1953)	
 Bulgaria (1999)	 United Kingdom (1953)	
 Czech Republic (1993)	<b>States in accession to Membership and Associate Members</b>	
 Denmark (1953)	 Croatia (2019)	
 Finland (1991)	 Cyprus (2016)	
 France (1953)	 India (2017)	
 Germany (1953)	 Lithuania (2018)	
 Greece (1953)	 Pakistan (2015)	
 Hungary (1992)	 Slovenia (2017)	
 Israel (2014)	 Turkey (2015)	
 Italy (1953)	 Ukraine (2016)	
 Netherlands (1953)		
 Norway (1953)		
 Poland (1991)		
 Portugal (1986)		
 Romania (2016)		
 Serbia (2019)		
 Slovakia (1993)		
 Spain (1961-1968, 1983-)		



# A World Collaboration!

---

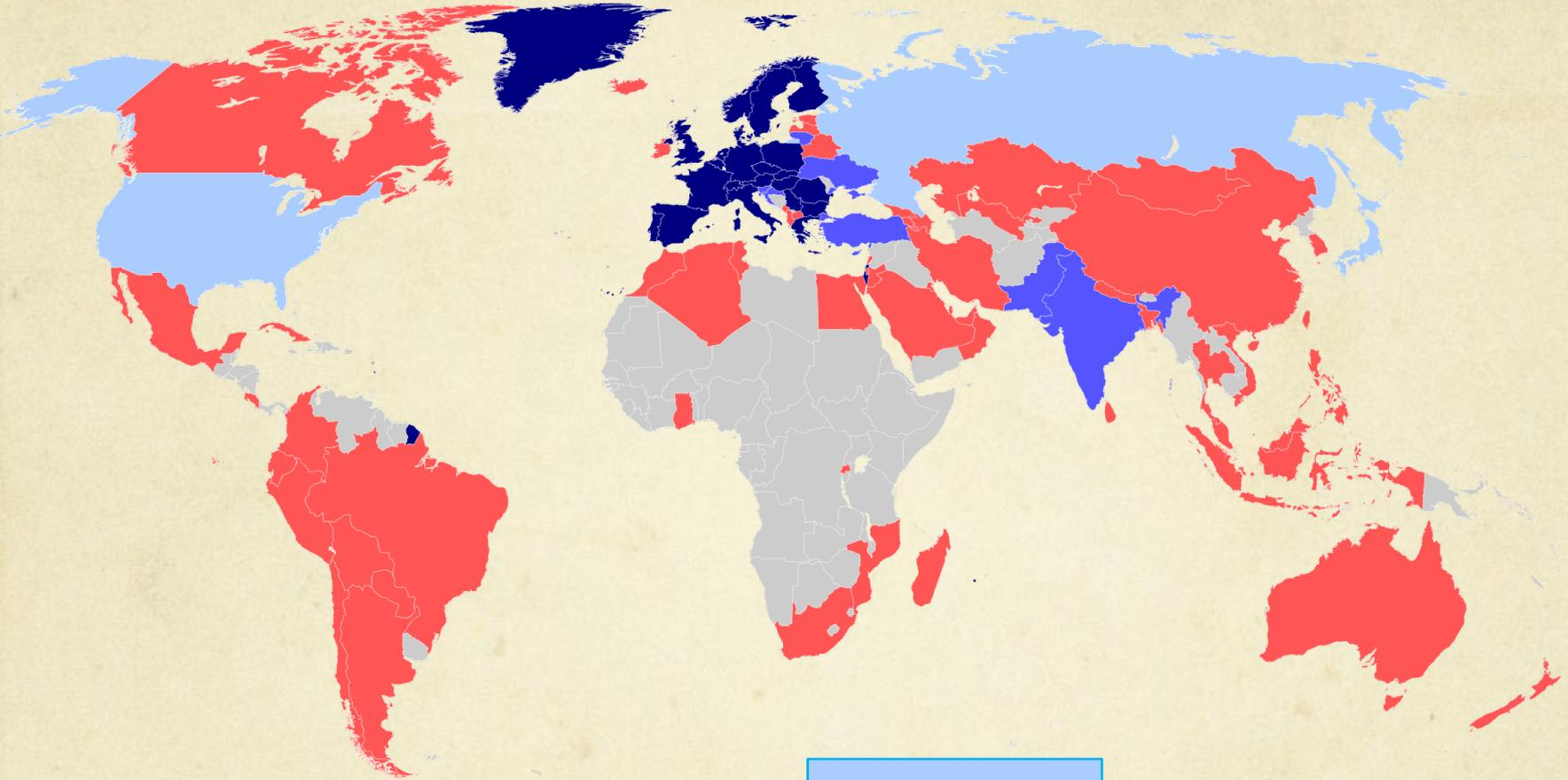

23 members

3 observers

8 associated

61 with agreements

# How Many Persons Are Working at CERN?

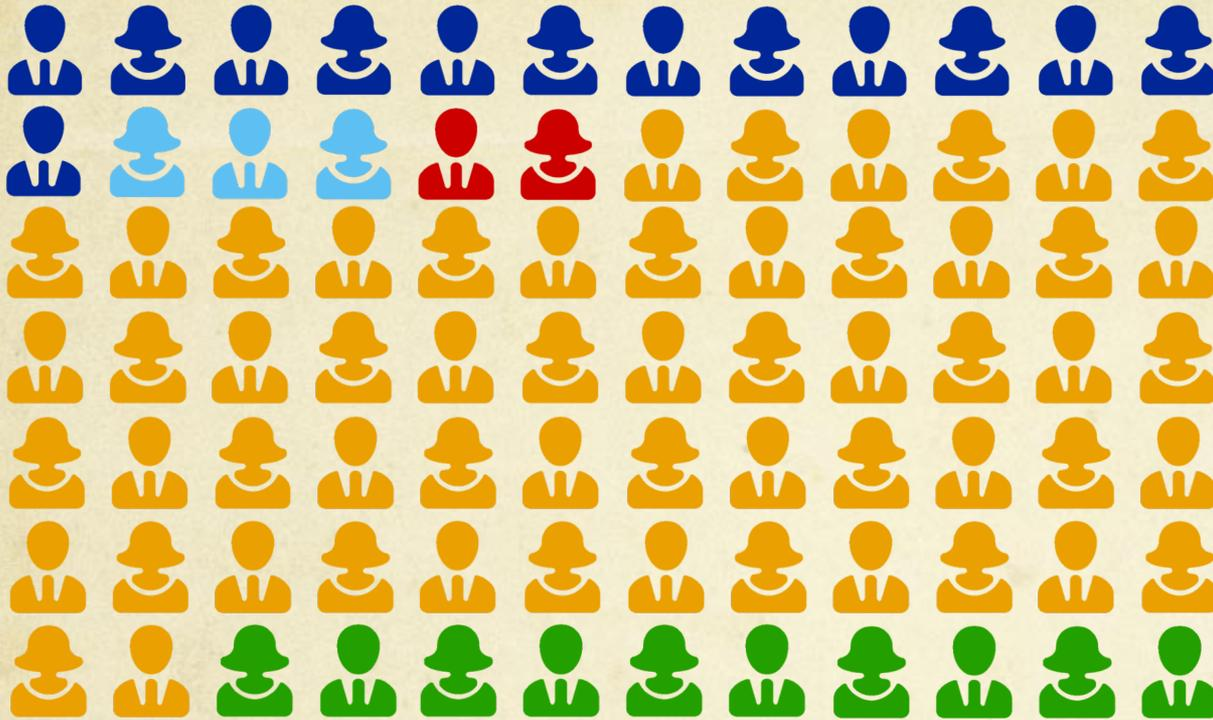

2 600 staff

800 fellows

apprentices

550 students

15 000 users

2 000 external  
companies

Total ~20 000!

A small town...



Cristiano Alpigiani



# Many Open Questions...Still Waiting for an Answer

## The matter-antimatter asymmetry

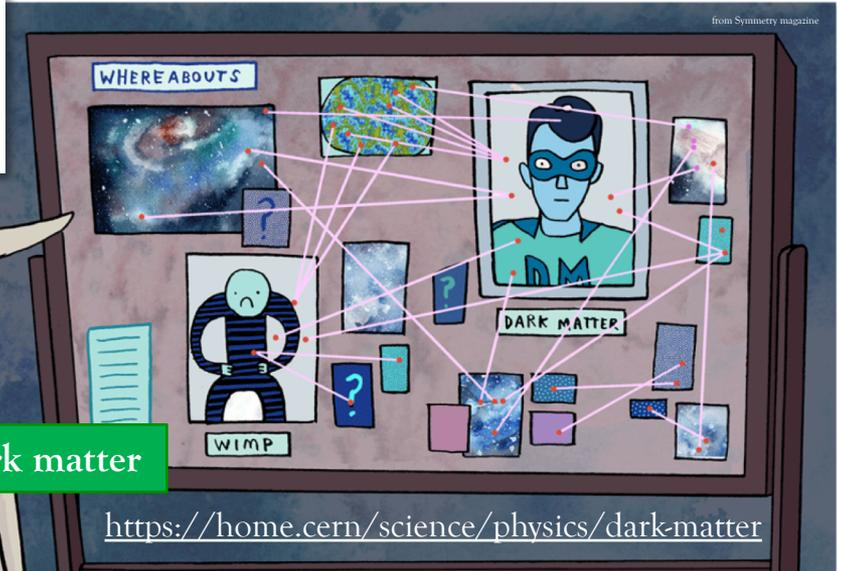
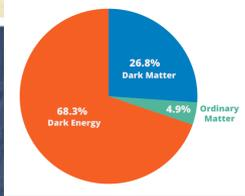
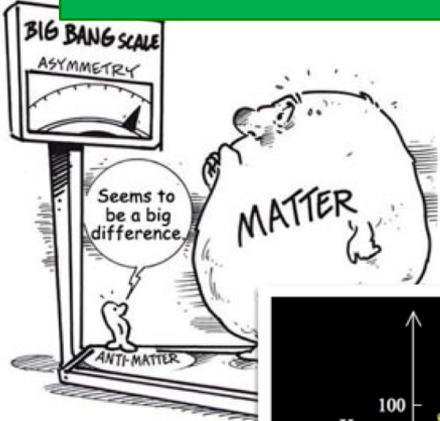

## The dark matter

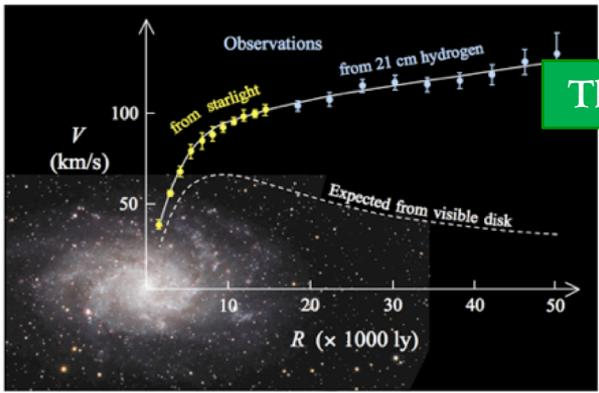

## The mass of the neutrinos

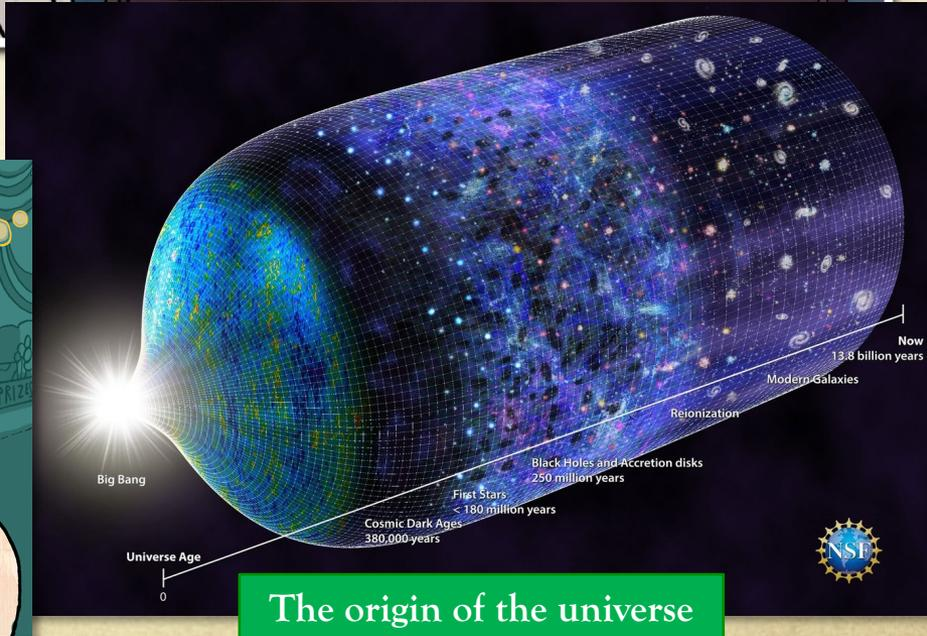

## The origin of the universe

Cristiano Alpighiani



# What is Matter Made of?

The Standard Model of particle physics

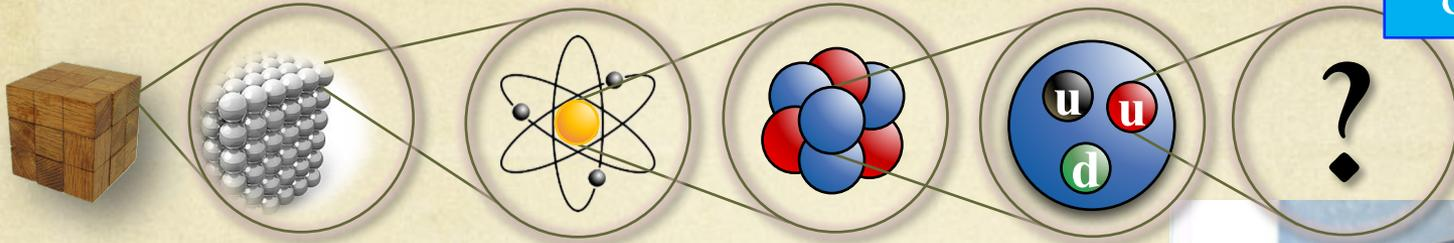

	three generations of matter (fermions)			interactions / force carriers (bosons)	
	I	II	III		
mass	≈2.2 MeV/c <sup>2</sup>	≈1.28 GeV/c <sup>2</sup>	≈173.1 GeV/c <sup>2</sup>	0	≈124.97 GeV/c <sup>2</sup>
charge	2/3	2/3	2/3	0	0
spin	1/2	1/2	1/2	1	0
	<b>u</b> up	<b>c</b> charm	<b>t</b> top	<b>g</b> gluon	<b>H</b> higgs
	<b>d</b> down	<b>s</b> strange	<b>b</b> bottom	<b>γ</b> photon	
	<b>e</b> electron	<b>μ</b> muon	<b>τ</b> tau	<b>Z</b> Z boson	
	<b>ν<sub>e</sub></b> electron neutrino	<b>ν<sub>μ</sub></b> muon neutrino	<b>ν<sub>τ</sub></b> tau neutrino	<b>W</b> W boson	

QUARKS

LEPTONS

SCALAR BOSONS

GAUGE BOSONS  
VECTOR BOSONS

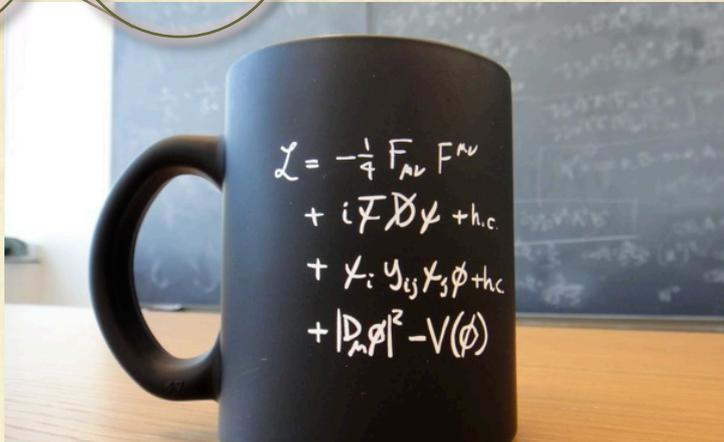

The most comprehensive theory of nature...up to now...



Gravity currently not fitting this "scheme"



[Video on CERN YouTube channel](#)  
[More on the Standard Model](#)

# Many Many Experiments...

The 4 LHC giants

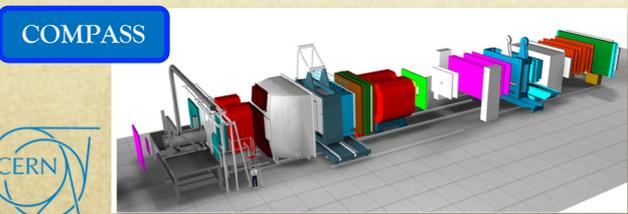
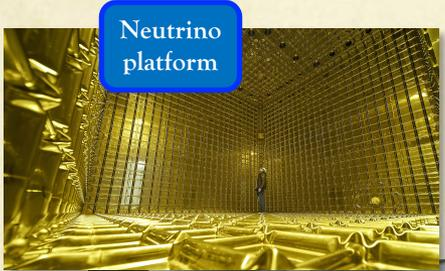
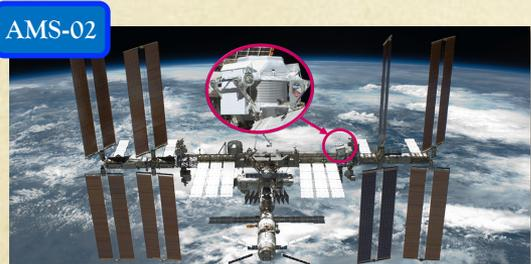
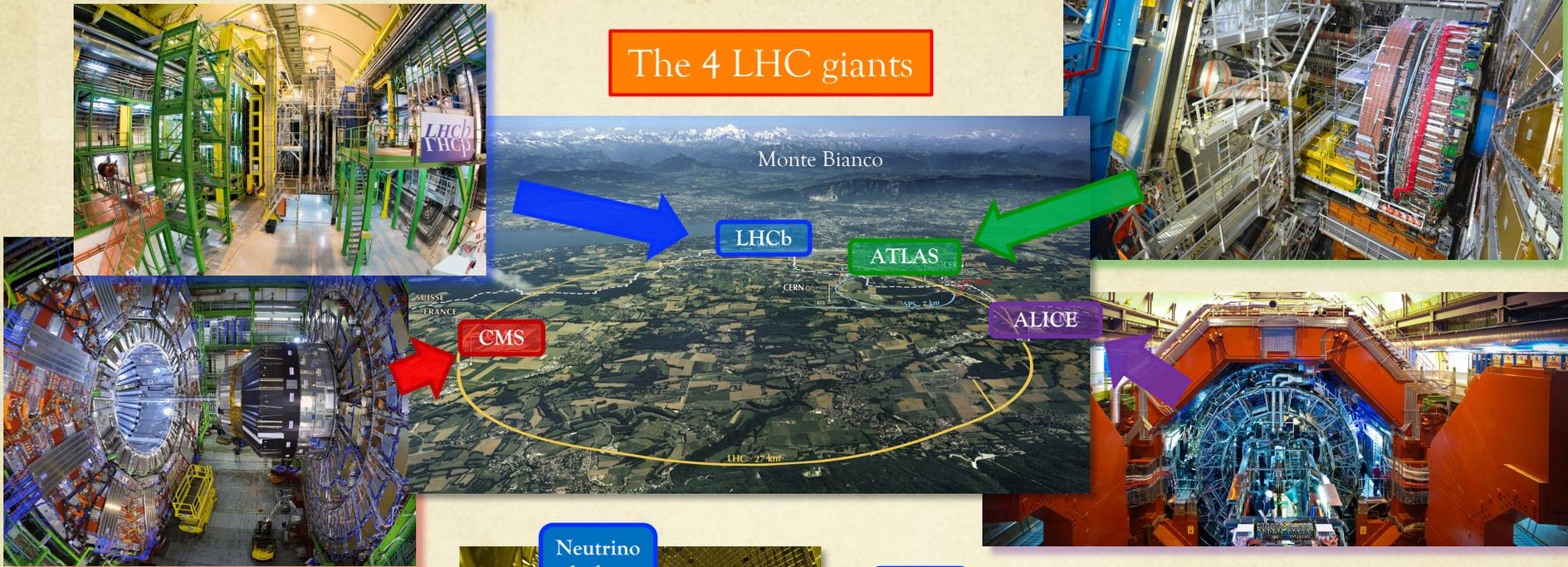

Cristiano Alpigiani

And many more...

# But We Have to Accelerate Particles...

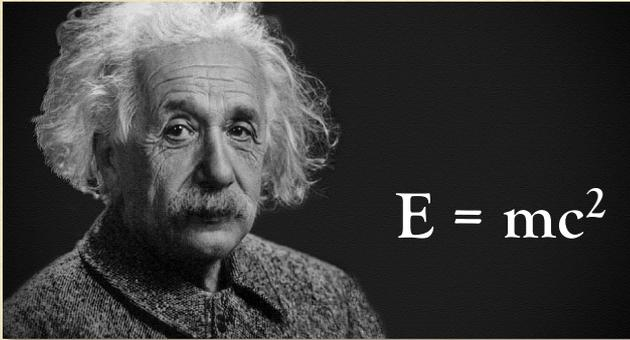

- A particle accelerator is a **super-microscope** to “see” tiny particles (quarks, lepton, etc)
- Accelerators can be used to transform energy into mass (and vice-versa)

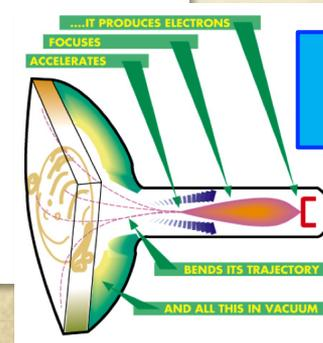
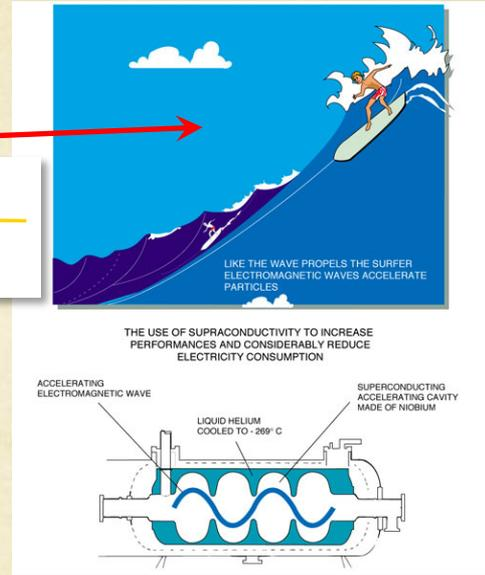
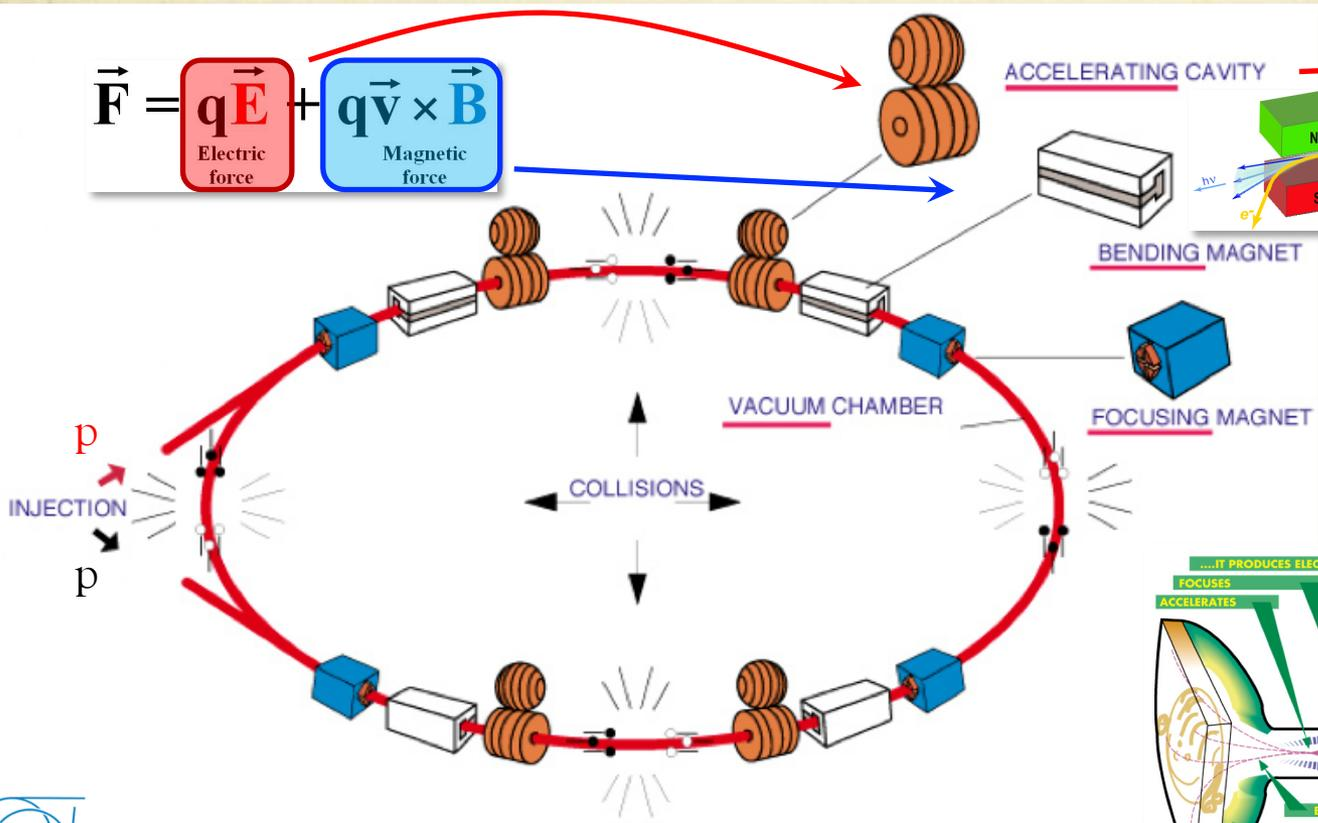

Not so different from an (OLD) TV set...

# The CERN Accelerator Complex

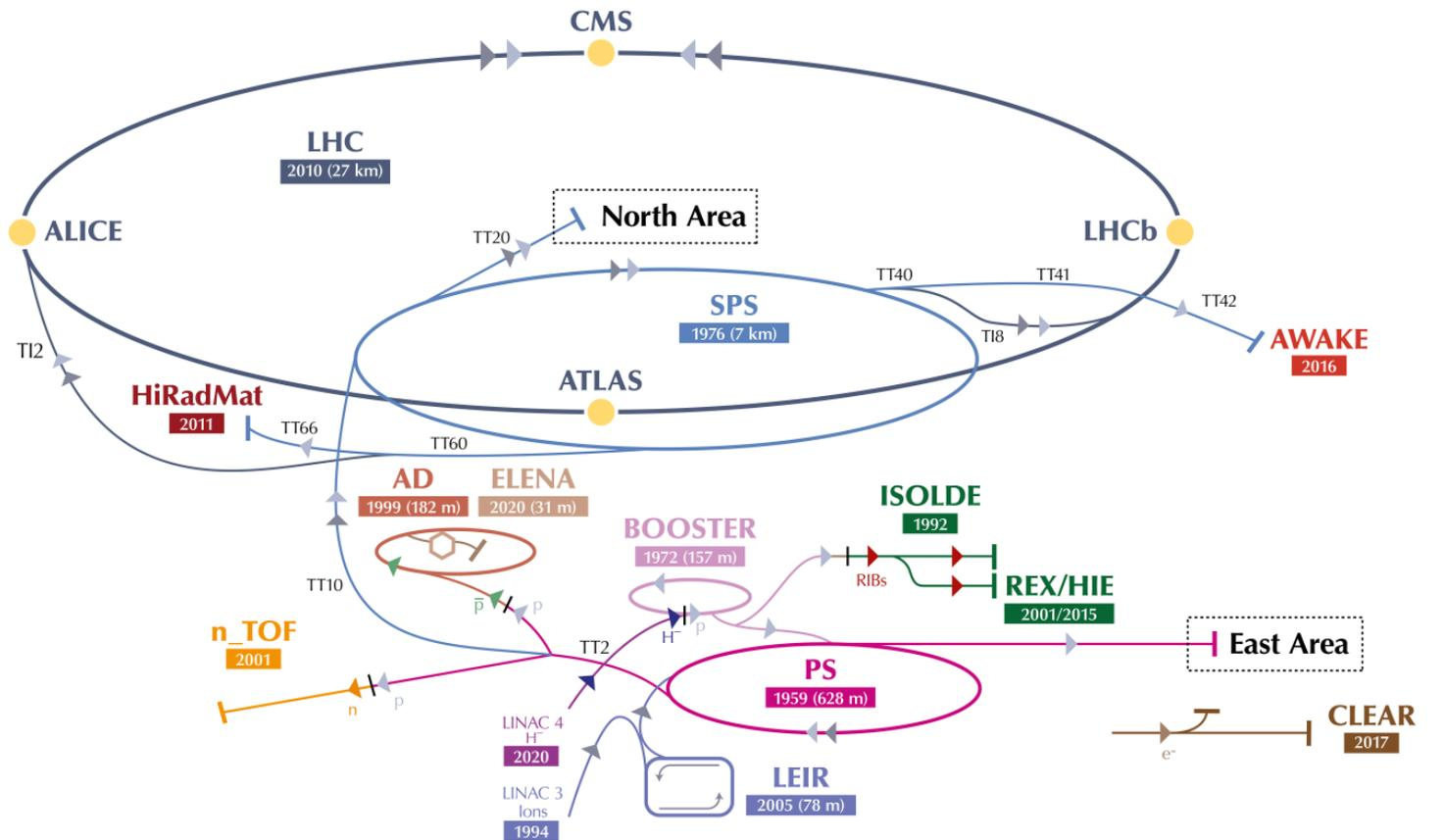

▶  $H^-$  (hydrogen anions)   ▶ p (protons)   ▶ ions   ▶ RIBs (Radioactive Ion Beams)   ▶ n (neutrons)   ▶  $\bar{p}$  (antiprotons)   ▶  $e^-$  (electrons)

LHC - Large Hadron Collider // SPS - Super Proton Synchrotron // PS - Proton Synchrotron // AD - Antiproton Decelerator // CLEAR - CERN Linear Electron Accelerator for Research // AWAKE - Advanced WAKEfield Experiment // ISOLDE - Isotope Separator OnLine // REX/HIE - Radioactive Experiment/High Intensity and Energy ISOLDE // LEIR - Low Energy Ion Ring // LINAC - LINEar ACcelerator // n\_TOF - Neutrons Time Of Flight // HiRadMat - High-Radiation to Materials



# Where Do we Take the Protons?

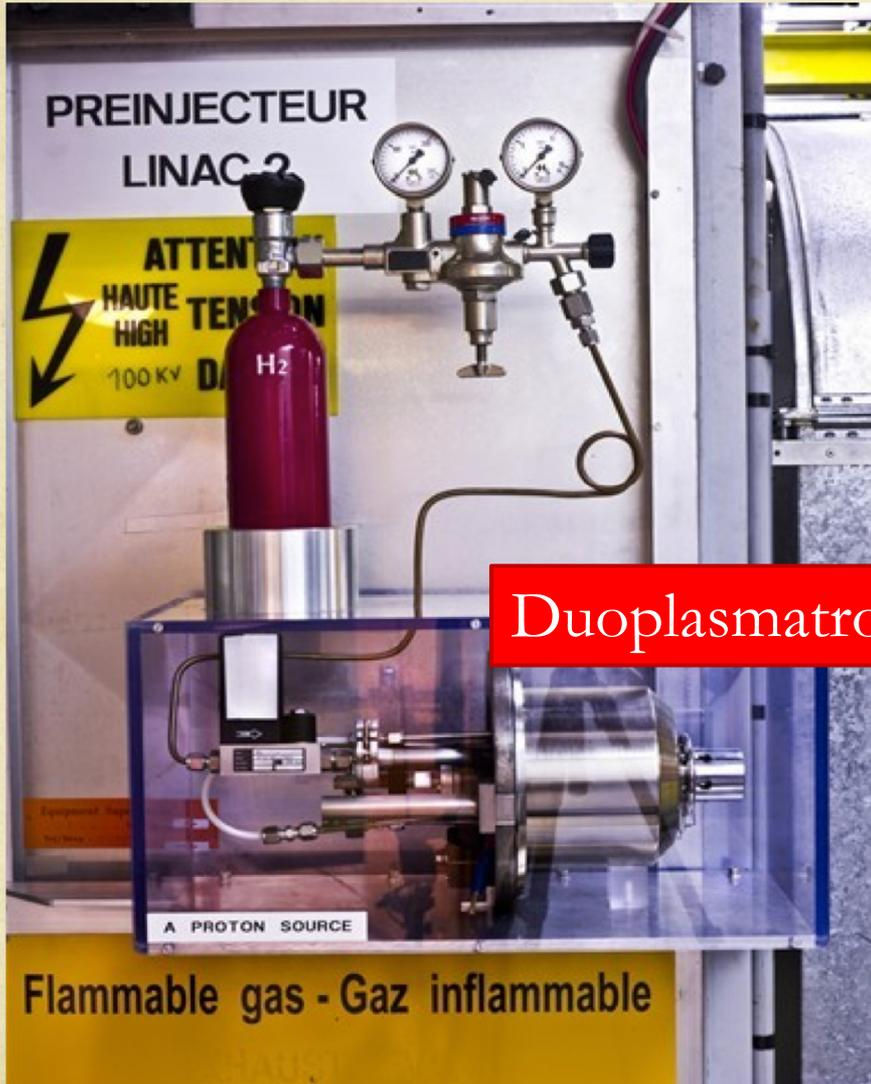

Duoplasmatron

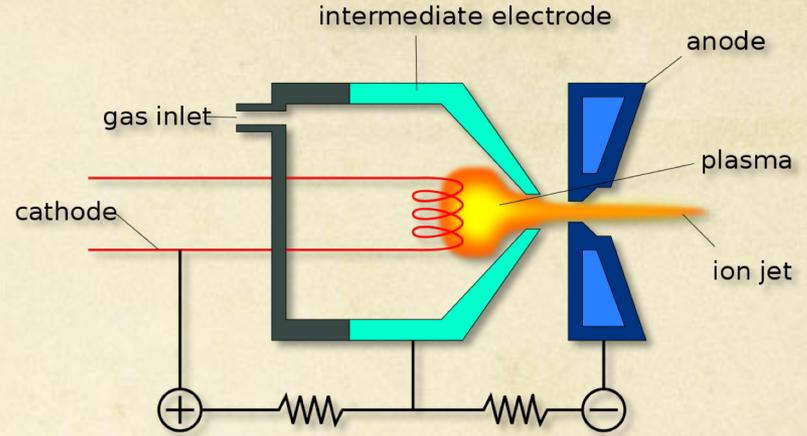

1. Cathode filament emits electrons into a vacuum chamber
2.  $H_2$  gas is introduced in very small
3. Gas become charged or ionised through interactions with the free electrons
4. Plasma is accelerated through a series of charged grids

# The Bending Magnets

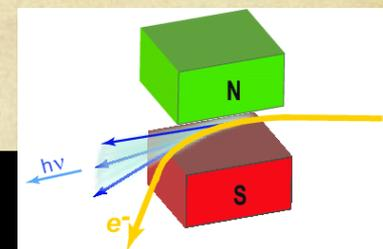

-271 °C (1.9 K)

Niobium-Titanium (Nb-Ti)

$$\vec{F} = q\vec{E} + q\vec{v} \times \vec{B}$$

Electric force      Magnetic force

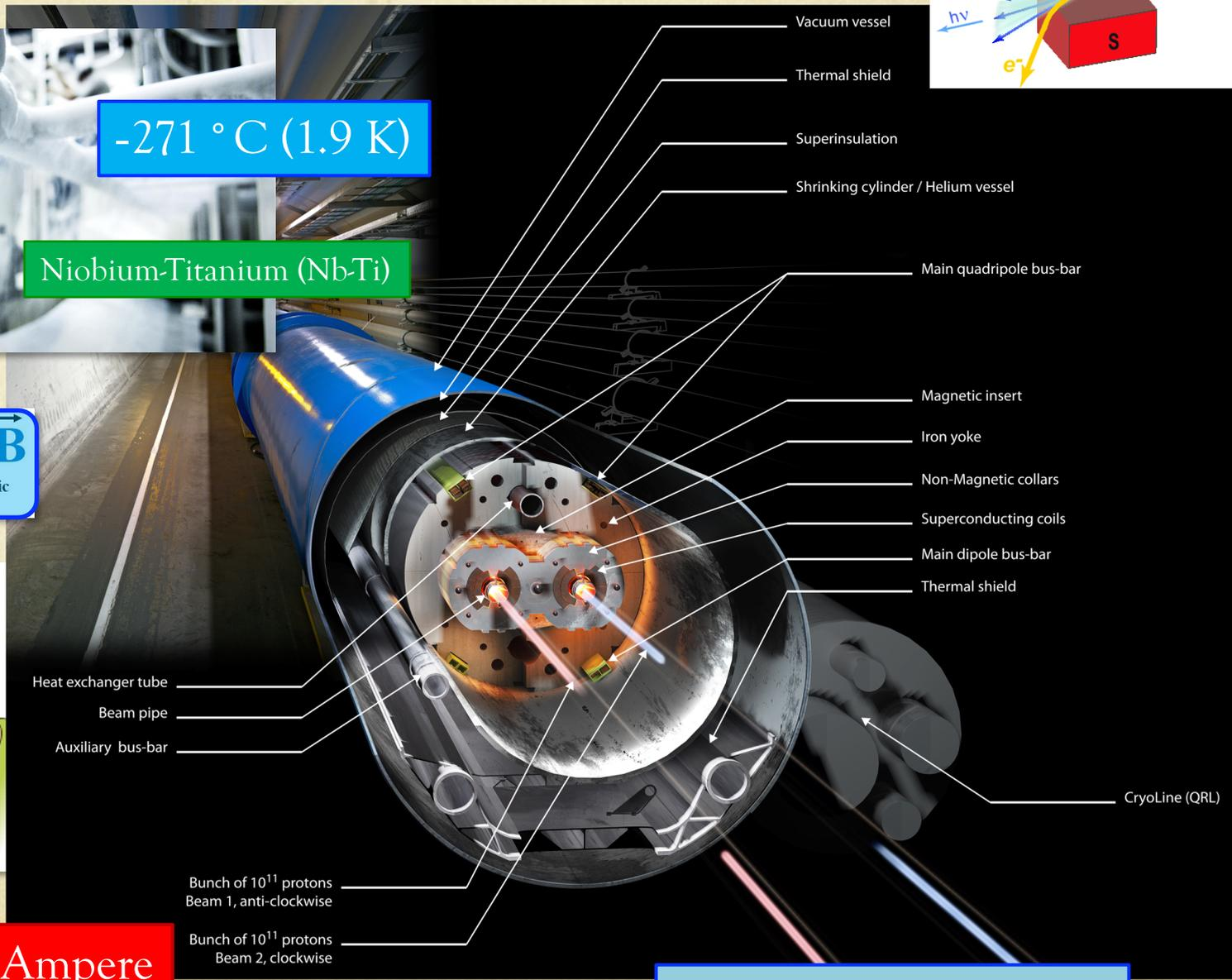
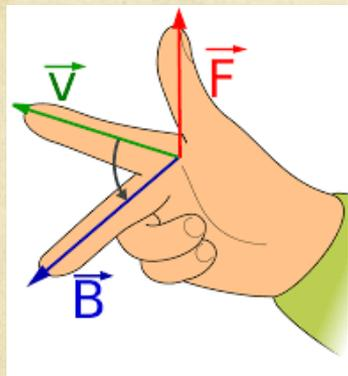

13,000 Ampere

More on superconductivity?

# A Very Powerful Camera



## Detector characteristics

**Width:** 44m  
**Diameter:** 22m  
**Weight:** 7000t

CERN AC - ATLAS V1997

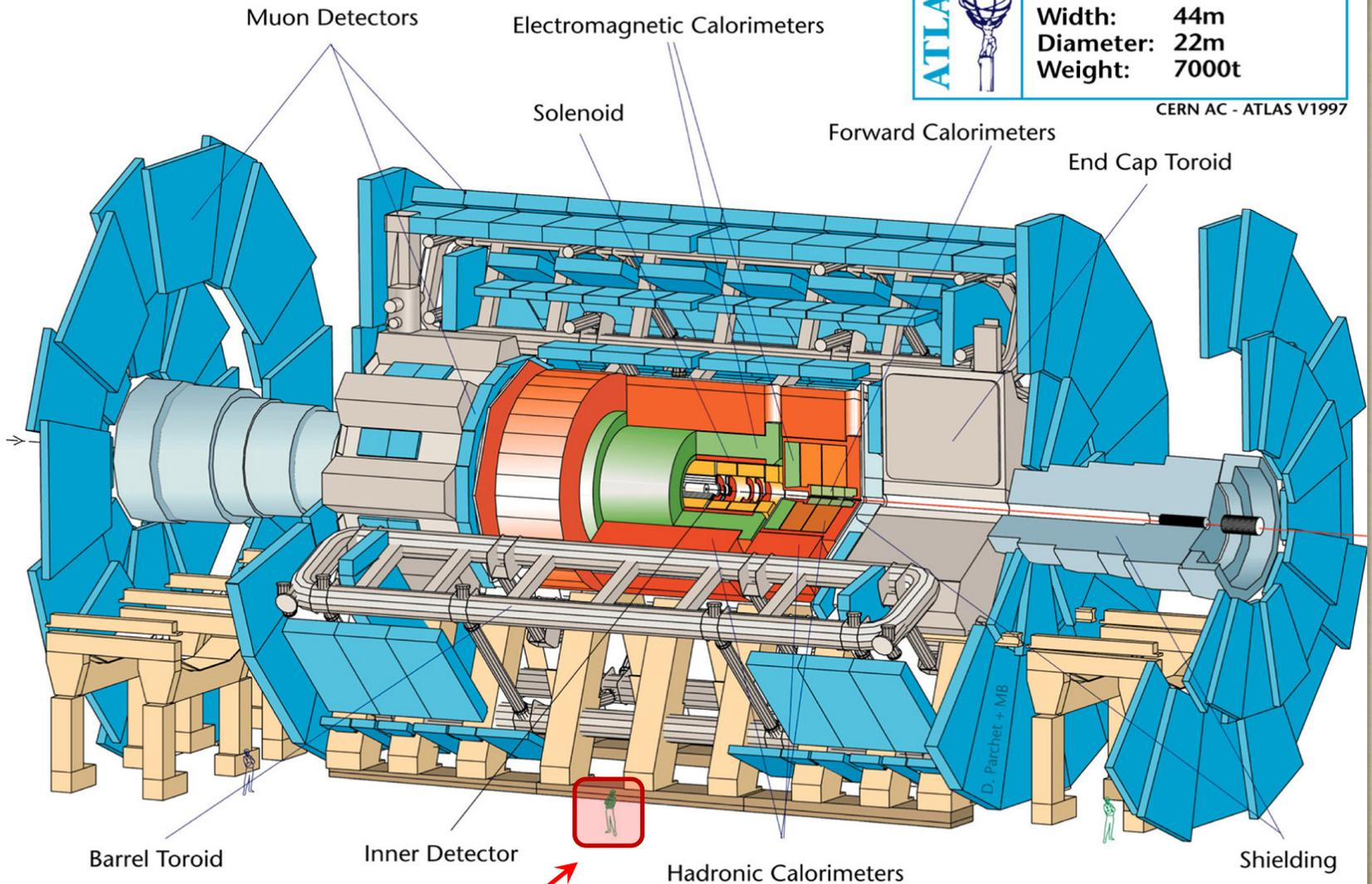

A person...

Cristiano Alpigiani

<https://atlas.cern>

# A Very Powerful Camera

A slice of ATLAS

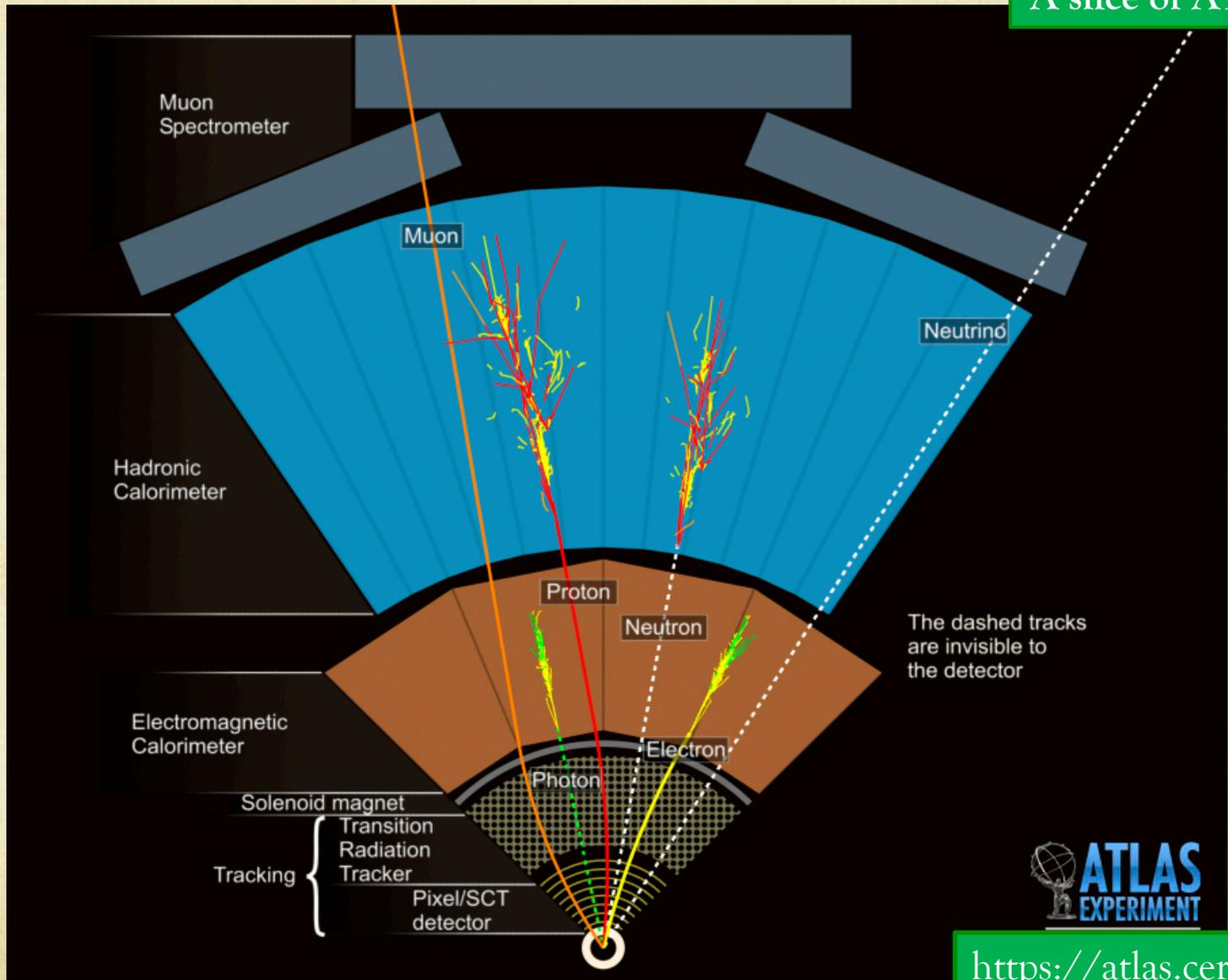

<https://atlas.cern>



# The LHC Computing Grid

The largest computing grid



- 42 countries
- 170 data centres
- Over 2 millions tasks executed every days
- 1 million computer cores
- 1 storage exabyte

Live talk: from data to discovery (J. Catmore)

# CERN is Not Only Fundamental Research

Technology transfer in benefit of society

<https://kt.cern/>

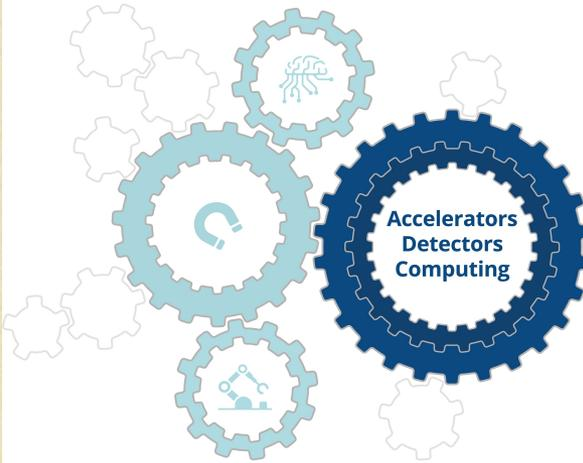

- Medical & Biomedical Technologies
- Aerospace Applications
- Cultural Heritage
- Environment
- Industry 4.0
- Safety
- Emerging Technologies

Medical applications

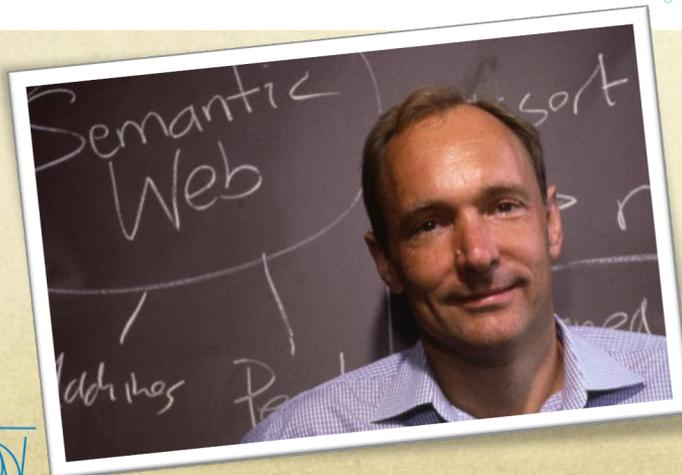
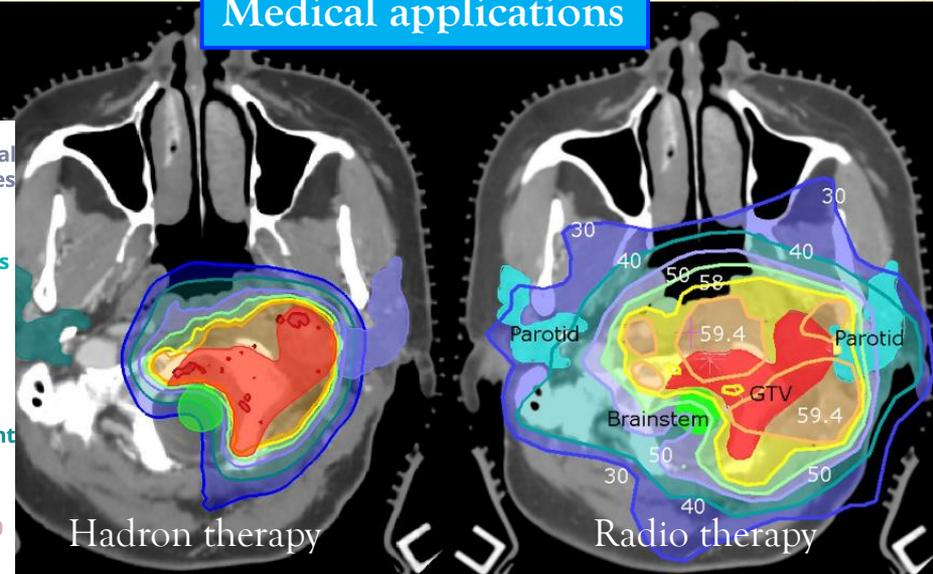

Humanitarian missions

# CERN Against COVID



<https://againstcovid19.cern>

Cristiano Alpigiani

# CERN Opportunities for Students

---



- **Many opportunities for a student** (visit <https://careers.cern/students>)
  - Summer Student Programme
  - CERN Openlab Summer Student Programme
  - Short-term Internship Programme
  - Doctoral Student Programme
  - Marie-Curies PhD positions
  - Technical Student Programme
  - Administrative Student Programme
  - Opportunities reserved for students with disabilities
  - Beamline for Schools → <https://beamlineforschools.cern>

# Further Research Material

---

- Want to play with some LHC data? [CERN Open Data](#)
- Want more photos or outreach material? [CERN Document Server \(Multimedia and Outreach\)](#)
- Want to know more? [Upcoming events @CERN](#) (for general public, but can select a different audience)
- More about CERN history? See [here](#) !
- Art @CERN? See [here](#)!
- Want to “see” particle collisions? [ATLAS event displays](#), [Other event displays](#)
- And much more on <https://home.cern>

Thank you!

BACKUP

# Dark Matter / Dark Energy

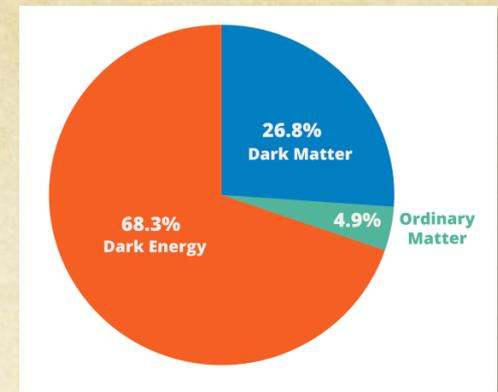

- First observed by Fritz Zwicky → velocity dispersions of galaxies in the Coma cluster (idea neglected for 40 years!)

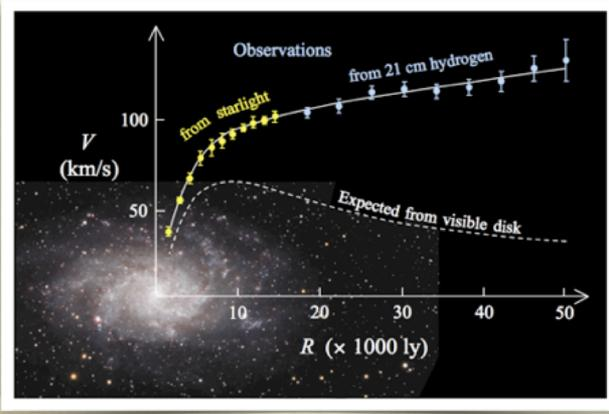

- Precisely measured by Vera Rubin → velocity of gas near Andromeda
  - Estimated factor of 10 more dark mass than visible mass

**Indirect detection:** DM-DM annihilation process

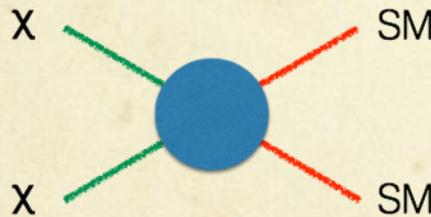
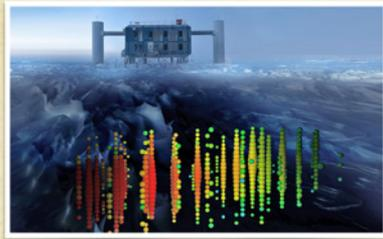

**Direct detection:** recoil from DM-nucleus scattering

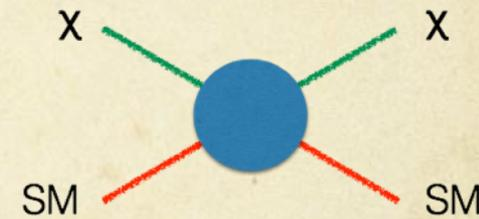
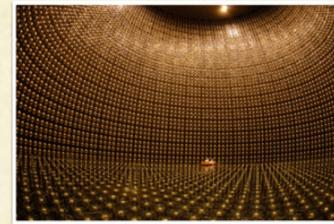

- ✓ No DM interaction with the detector → missing  $E_T$
- ✓ Initial state radiation to detect it (jets, photons,  $W$ , ...)
- ✓ Searches for high-mass di-jet resonances

At LHC

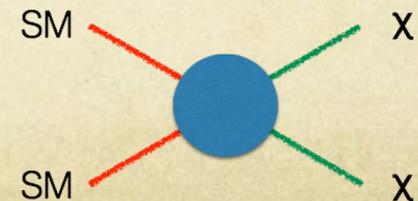

# Dark Matter / Dark Energy

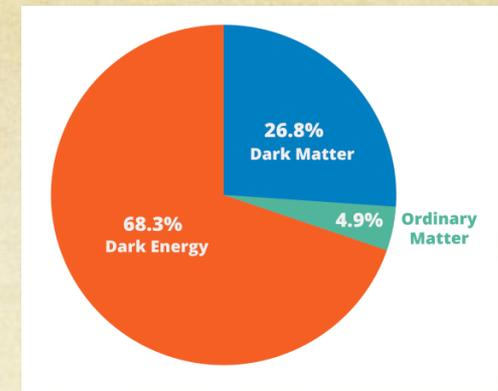
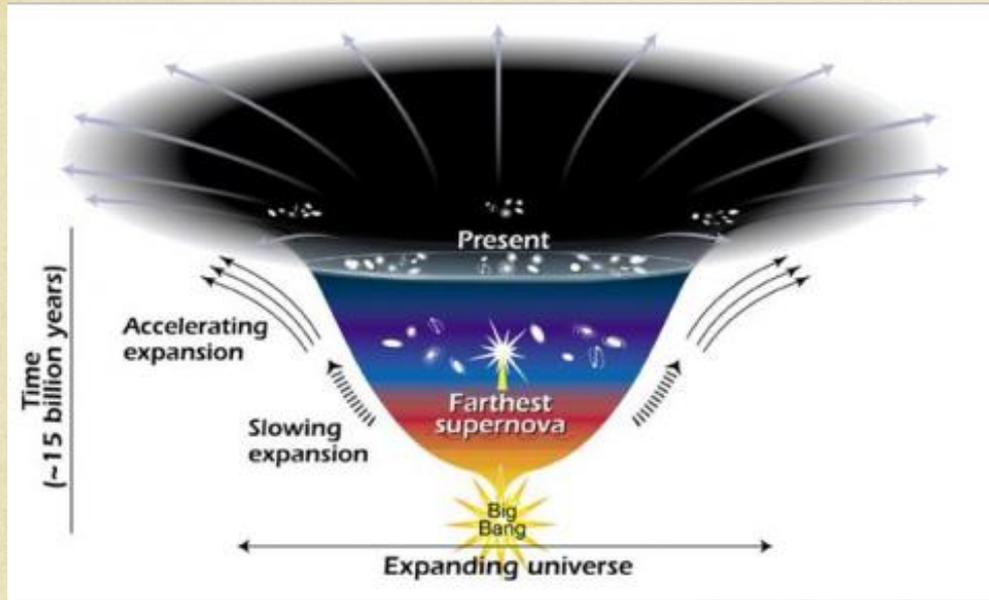

Dark energy is responsible for the acceleration of the Universe expansion

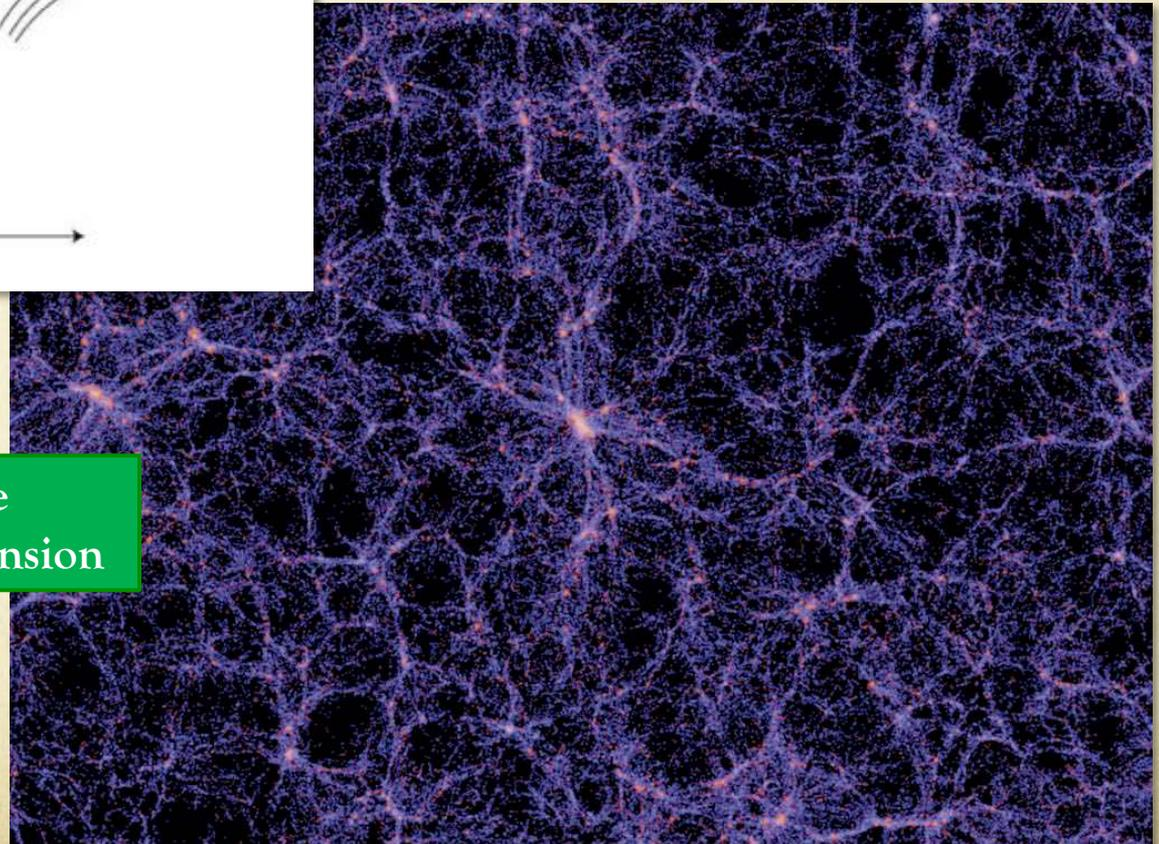

# The Bending Magnets

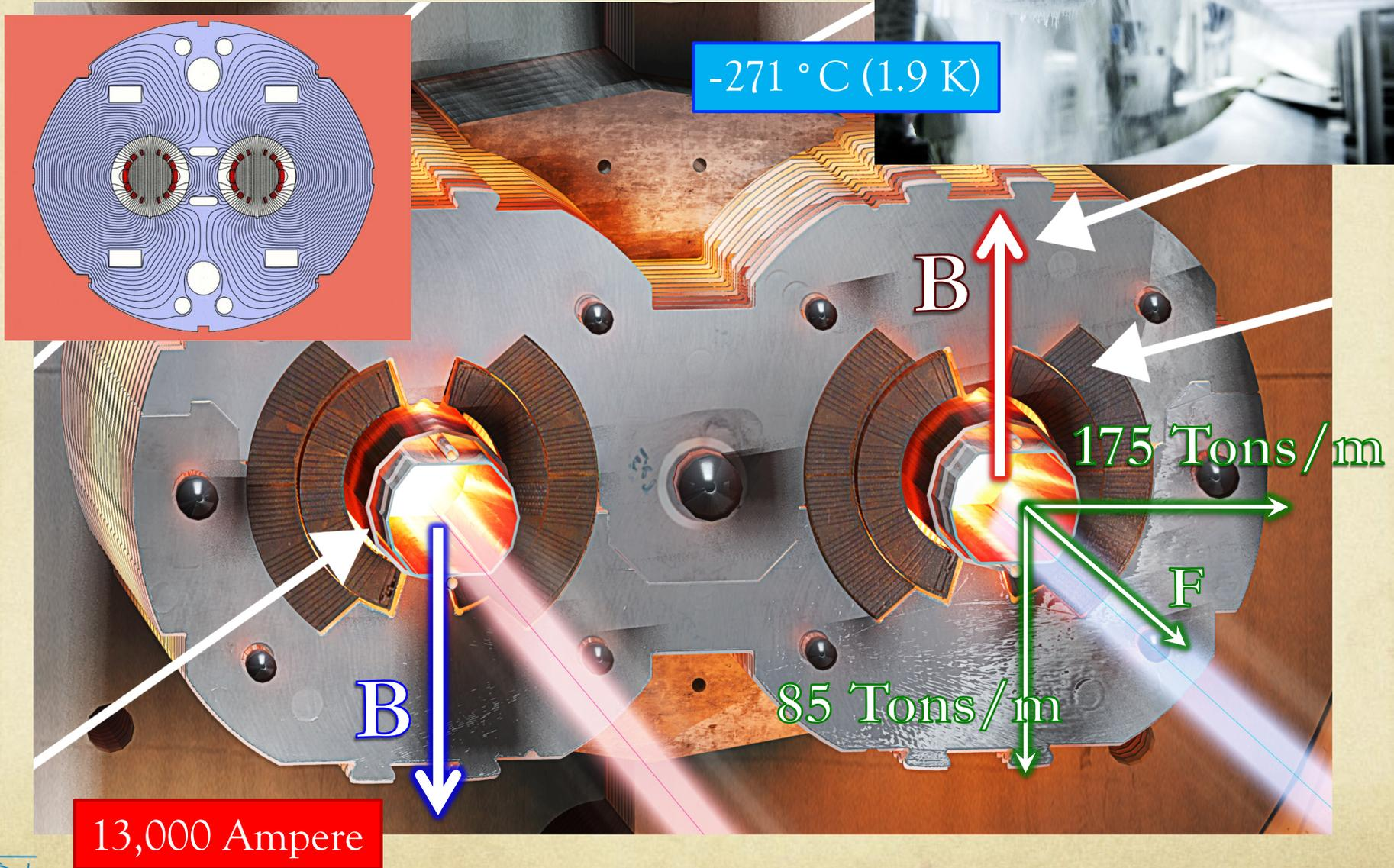

# The Superconductors

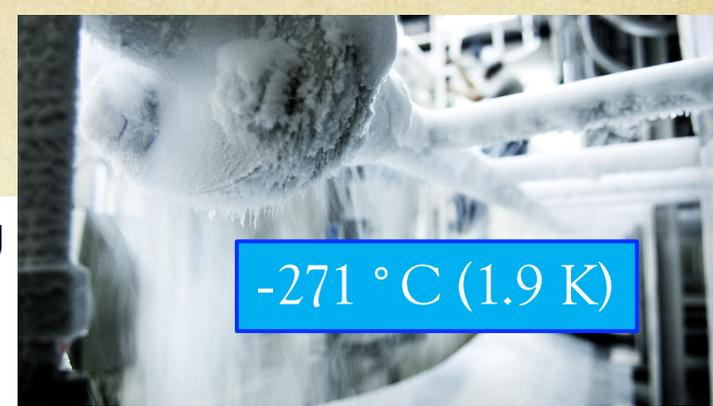

superconducting cable

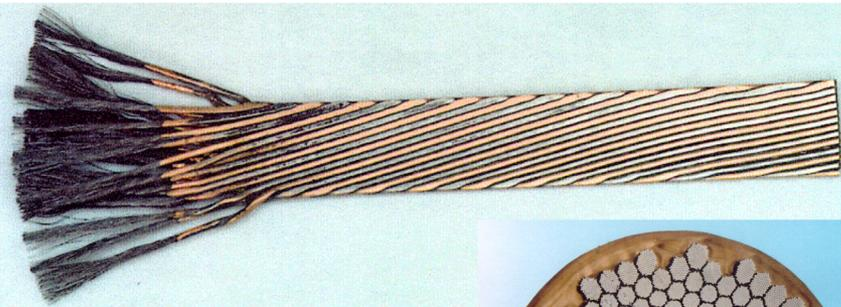

SC strand

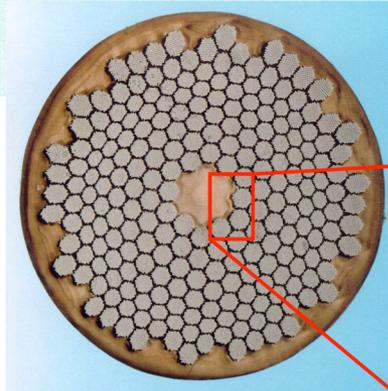

SC filament



13,000 Ampere

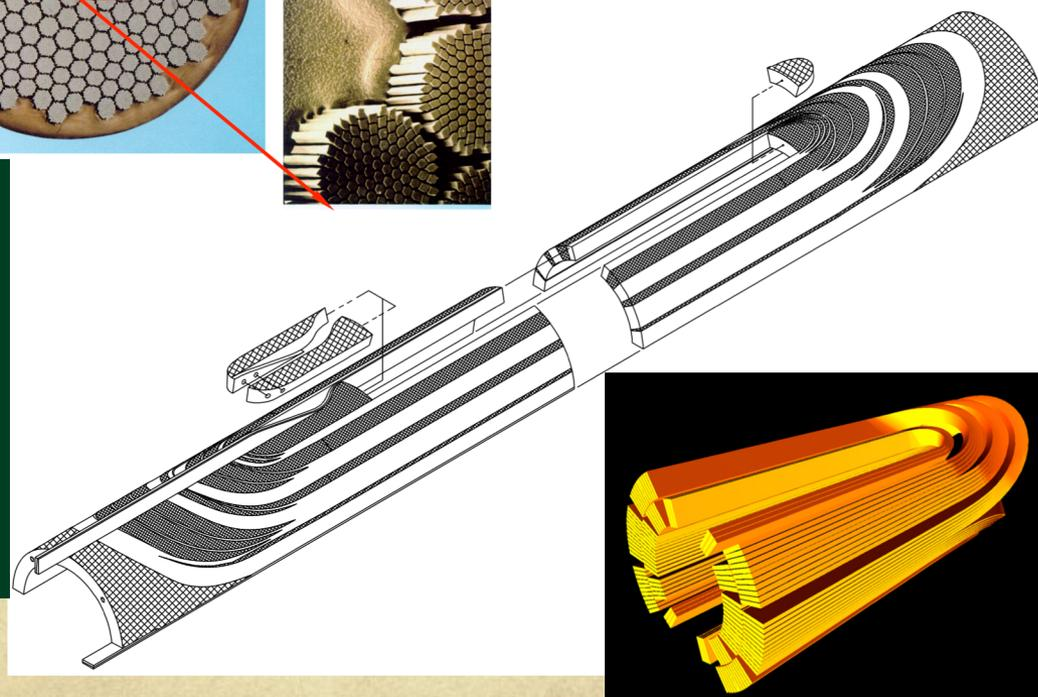
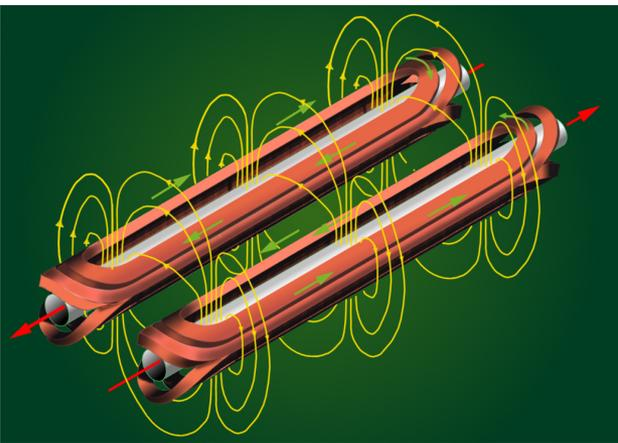

# Antimatter

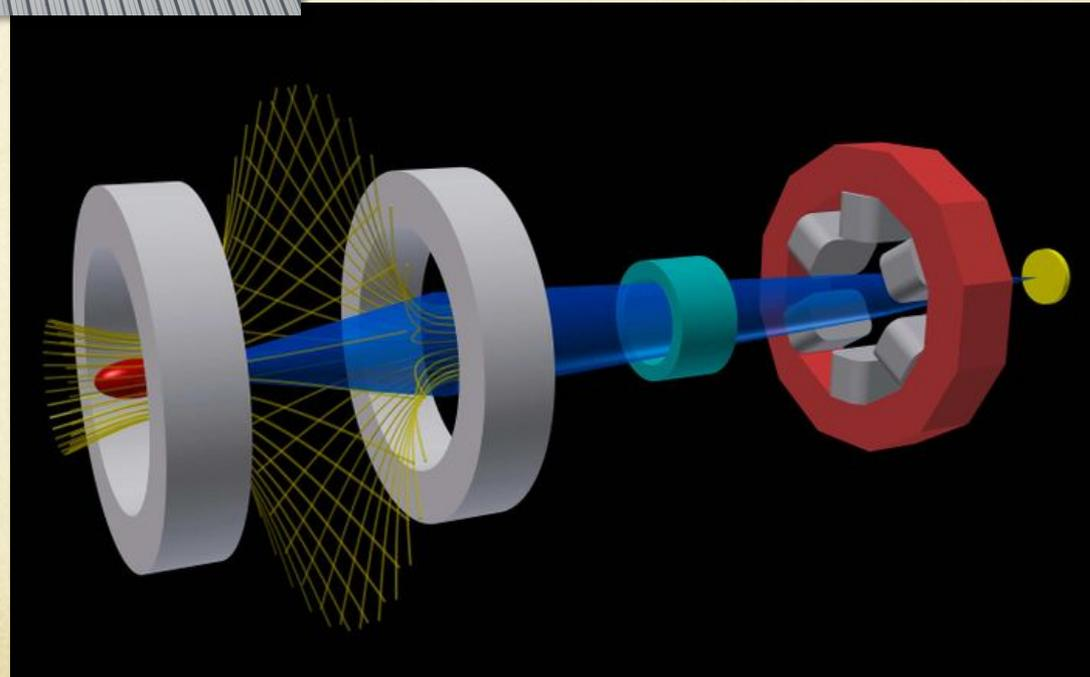
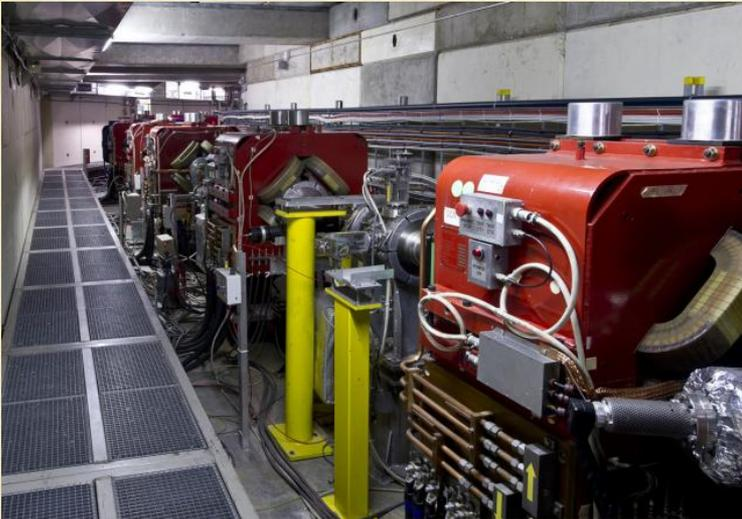
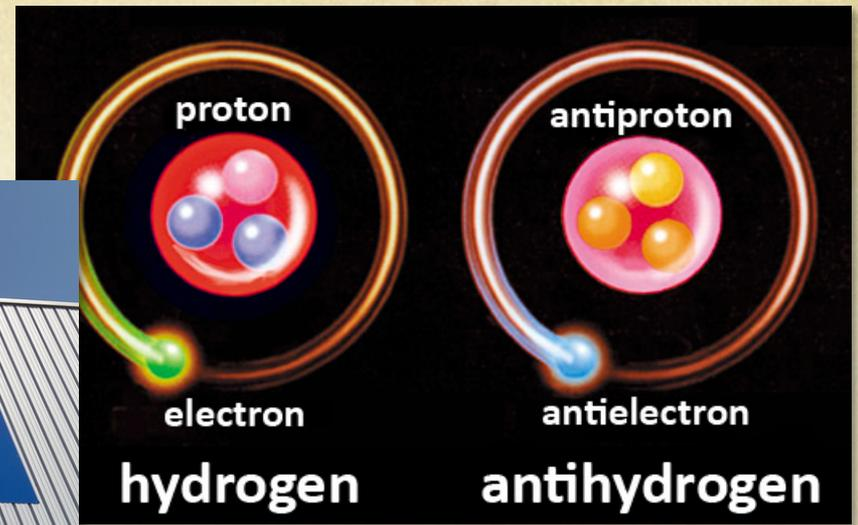

# CERN is...

---

...a scientific laboratory, that devises its own solutions



SCIENCE • TECHNOLOGY • ENGINEERING + ARTS • MATHEMATICS

## SCIENCE

- Observing
- Experimenting
- Making predictions
- Asking questions

## TECHNOLOGY

- Being inventive
- Using tools
- Making things work
- Identify issues,
- Using computers

## ENGINEERING

- Problem solving
- Using materials
- Designing & creating
- Building

## ARTS

- Creativity
- Aesthetics
- Imagination
- Expressing individuality

## MATH

- Patterning
- Sequencing
- Exploring shapes, numbers, volumes and size