

Happy 25th Birthday COMPASS

Congratulations; what a great ride you've had!

Arguably the most comprehensive experimental detector system & collaboration to study hadron structure using complementary tools:

Muon (L,T) DIS, Hadron Scattering, DVCS and Drell-Yan

From 1995 (letter of intent) until to today:
~130 Diploma/Masters/Bachelor's Theses
~130 Ph.D. Theses
~10 Habilitation Theses
~75 Peer Reviewed Publications

A high bar for future experimental ventures

Low x behavior of $g_1(p)$!

A. Deshpande & V. W. Hughes
~1995 SMC (internal) analysis meeting

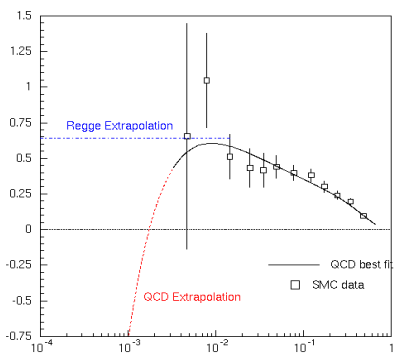

Regge: $g_1(x \rightarrow 0) \sim x^{-\alpha}$; $0 < \alpha < 0.5$

Clear need for low x measurements!

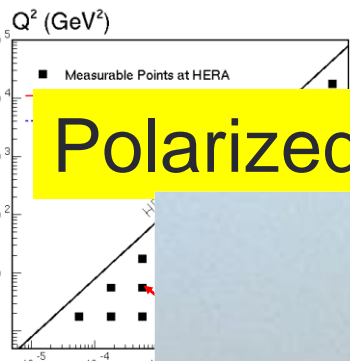

Polarized HERA or nuclei in HERA

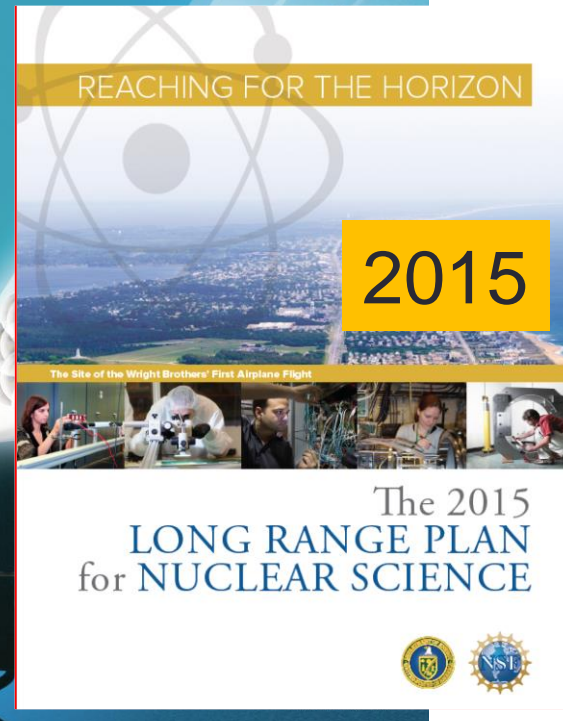
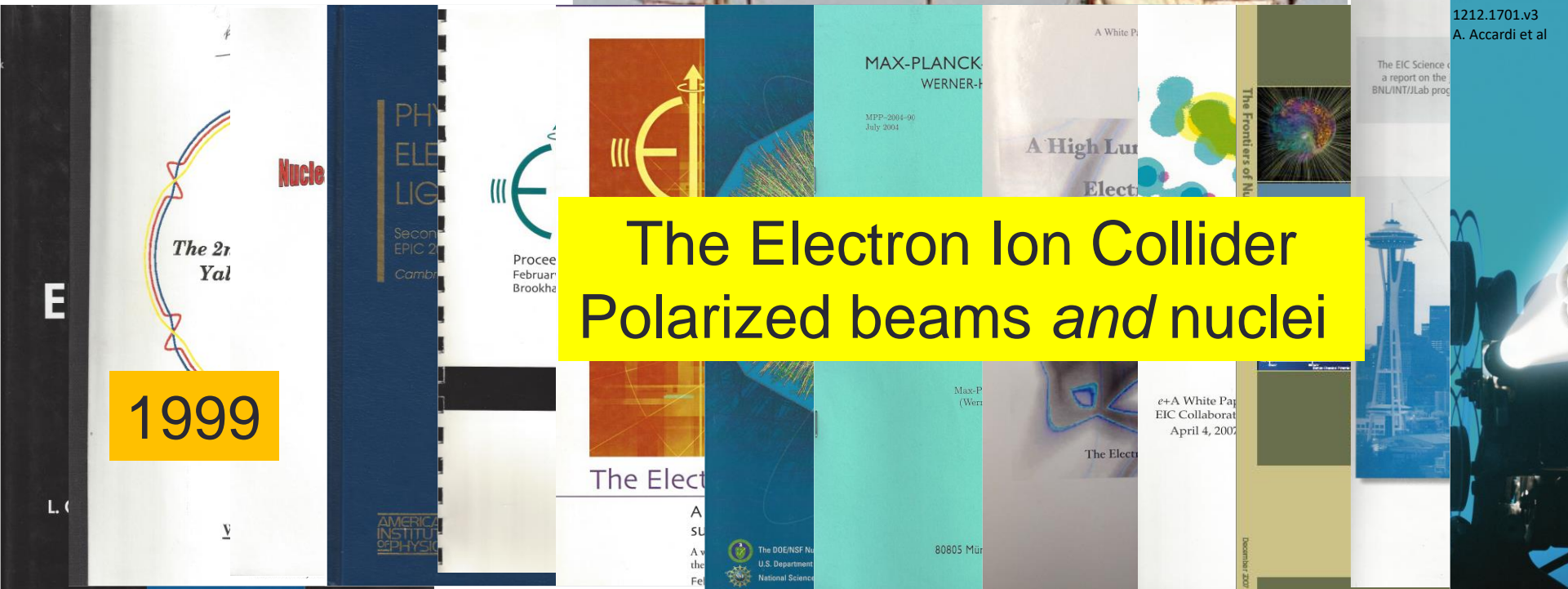
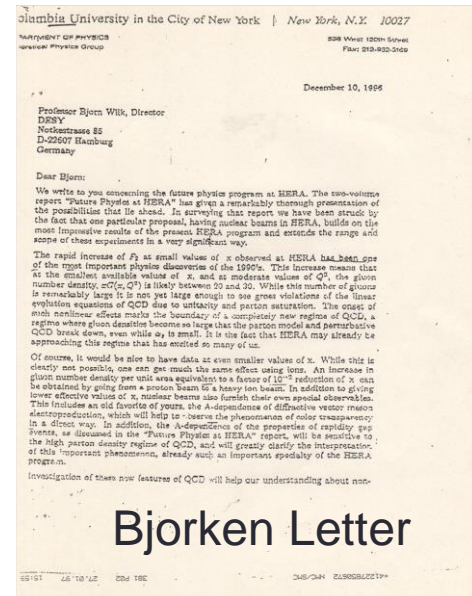
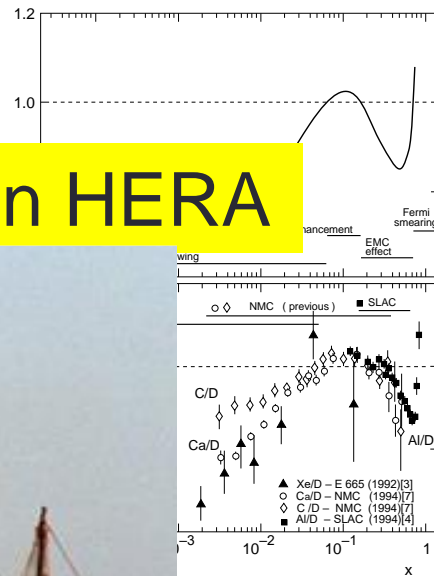

1999

2015

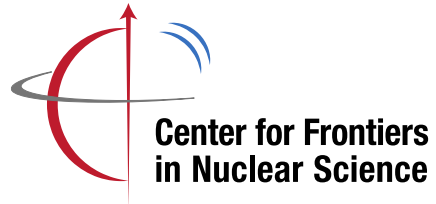

International Workshop on Hadron Structure and Spectroscopy - 2022

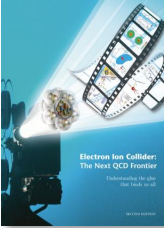
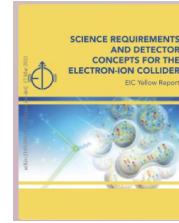

Electron Ion Collider: Science and Status

A new *tool* to study the glue that binds us all...

August 29-31, 2022



EIC Physics at-a-Glance

How are the sea quarks and gluons, and their spins, **distributed in space and momentum** inside the nucleon?

How do the **nucleon properties (mass & spin) emerge** from their interactions?

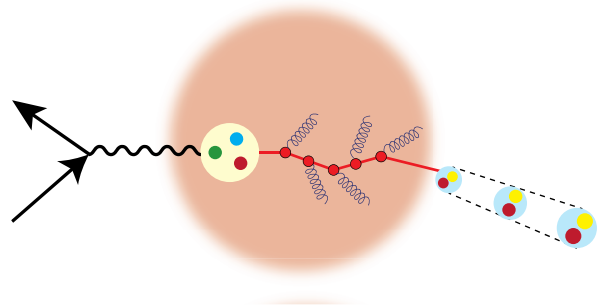
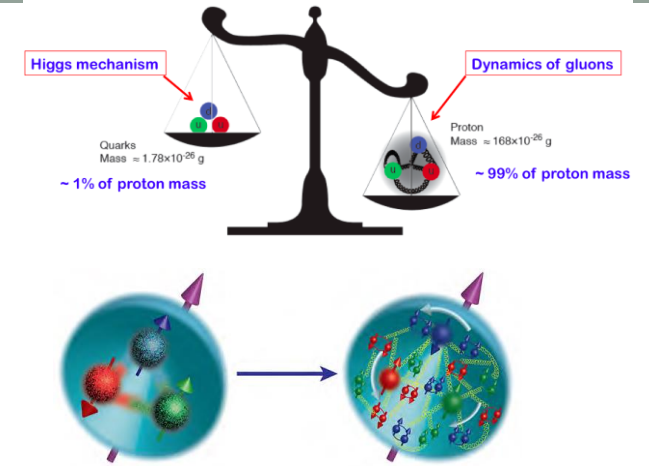

How do color-charged quarks and gluons, and colorless jets, **interact with a nuclear medium**?

How do the **confined hadronic states emerge** from these quarks and gluons?

How do the quark-gluon **interactions create nuclear binding**?

How does a **dense nuclear environment affect** the quarks and gluons, their correlations, and their interactions?

What happens to the **gluon density in nuclei**? Does it **saturate at high energy**, giving rise to a **gluonic matter with universal properties** in all nuclei, even the proton?

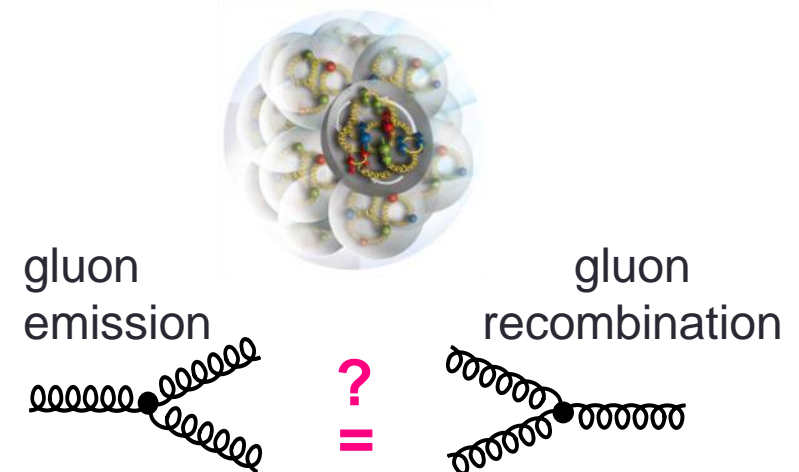

QCD Landscape to be explored by a new future facility

QCD at high resolution (Q^2) — weakly correlated quarks and gluons are well-described

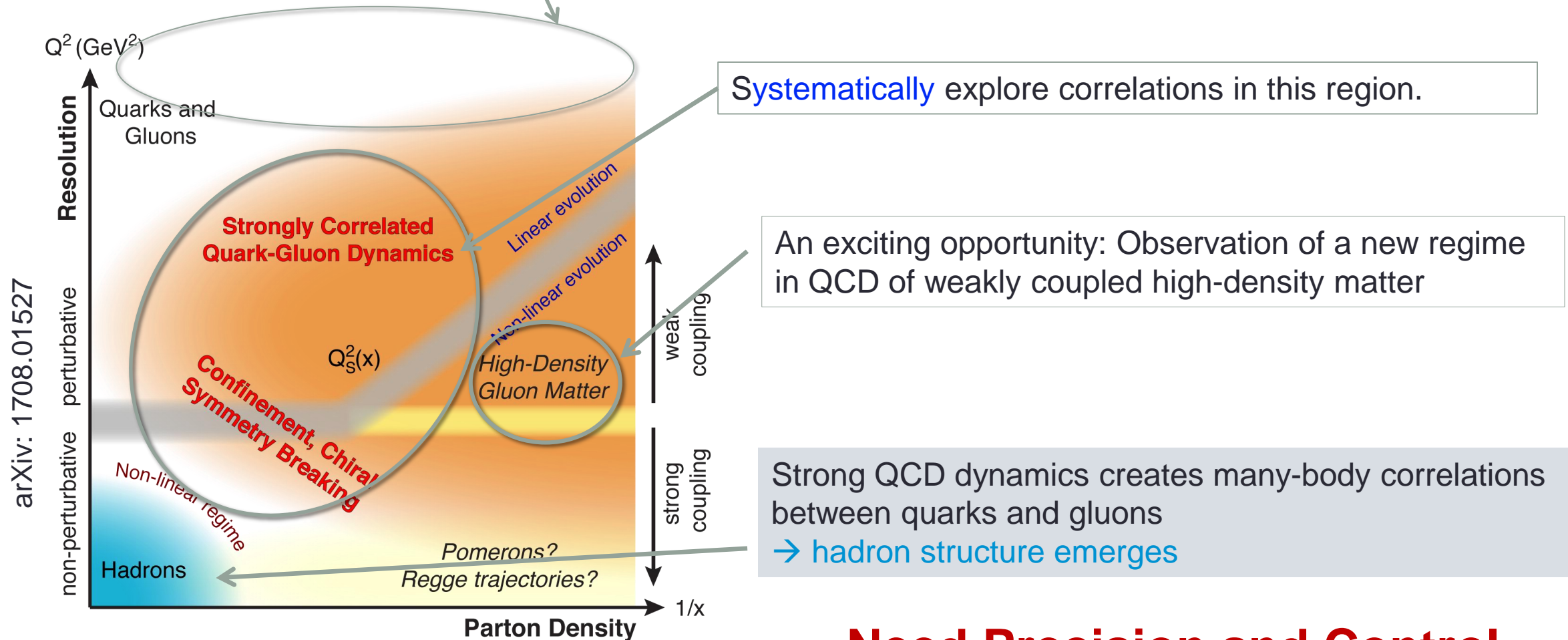

arXiv: 1708.01527



Need Precision and Control

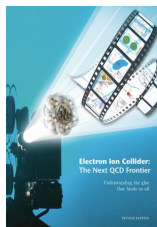

EIC science highlights

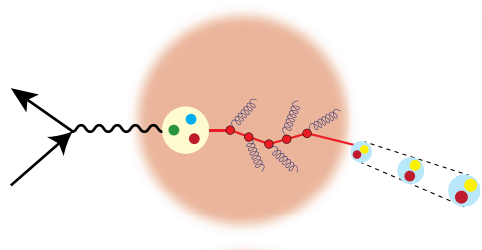
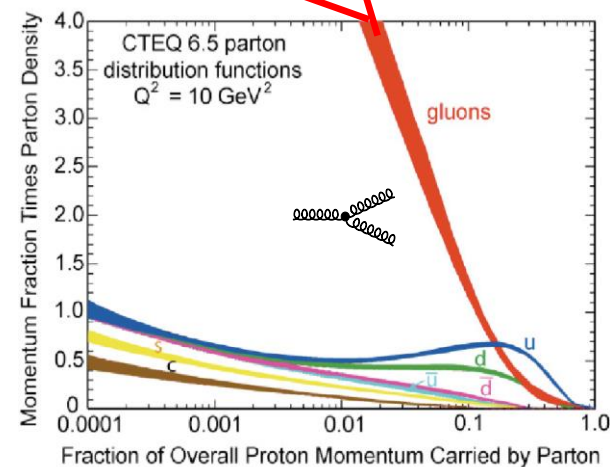
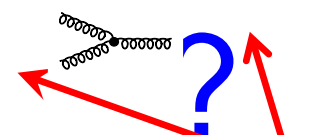
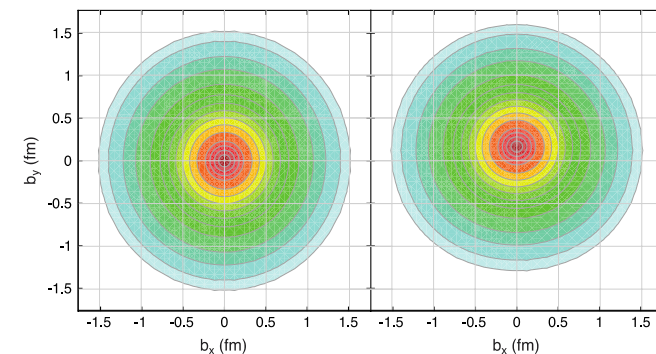
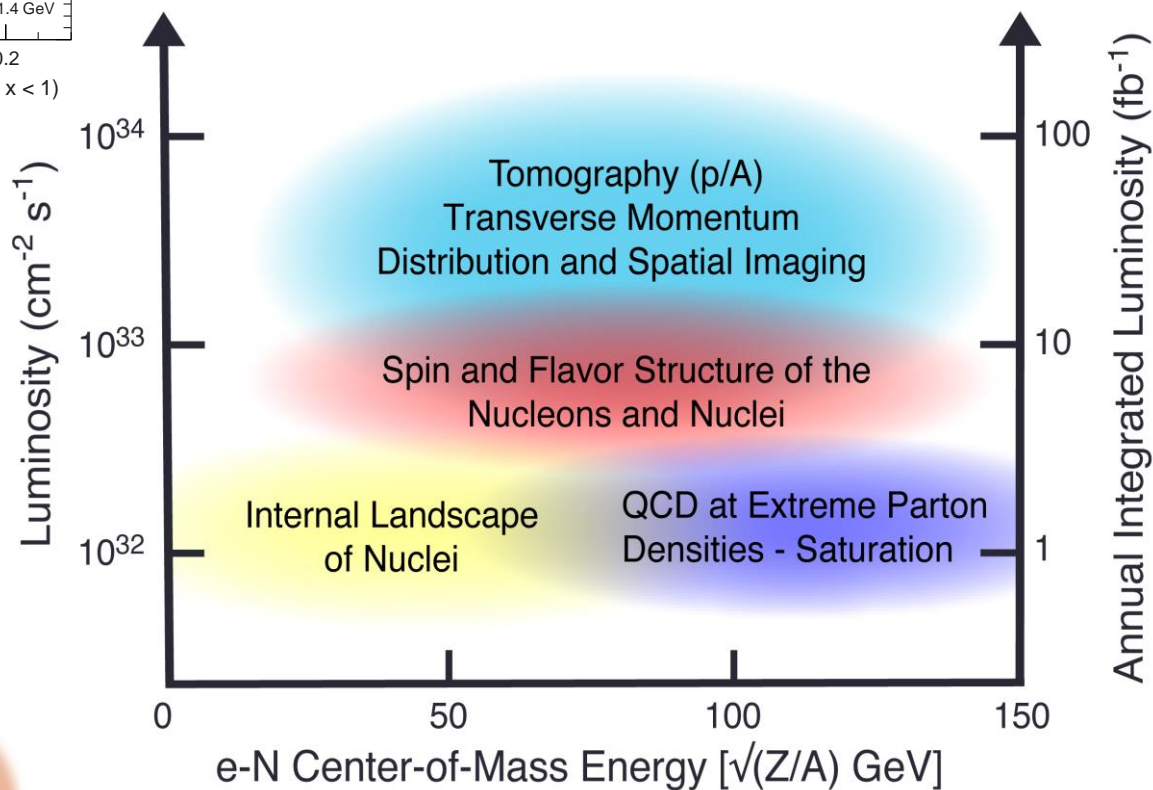
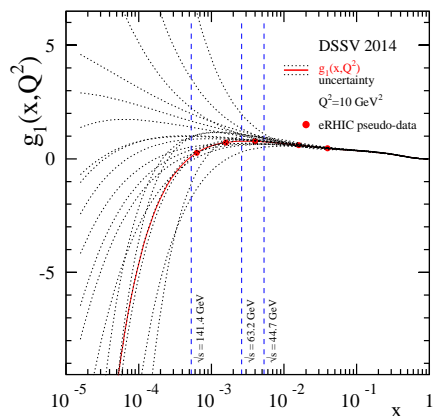
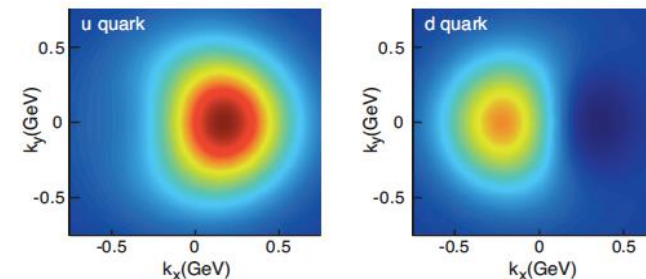
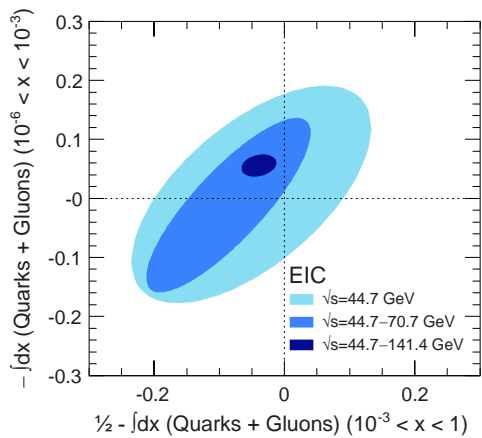



National Academy's Assessment

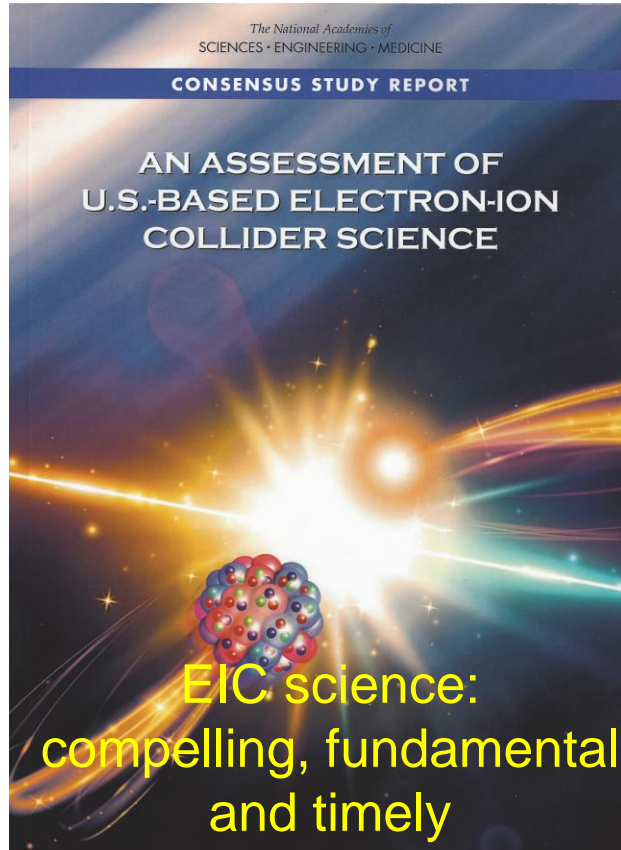

Physics of EIC

- Emergence of Spin
- Emergence of Mass
- Physics of high-density gluon fields

Machine Design Parameters:

- High luminosity: $up\ to\ 10^{33}\text{-}10^{34}\text{ cm}^{-2}\text{sec}^{-1}$
 - a factor $\sim 100\text{-}1000$ times HERA
- Broad range in center-of-mass energy: $\sim 20\text{-}140\text{ GeV}$
- Polarized beams e^- , p , and light ion beams with flexible spin patterns/orientation
- Broad range in hadron species: protons.... Uranium
- Up to two detectors well-integrated detector(s) into the machine lattice

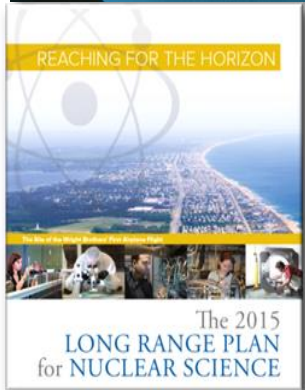
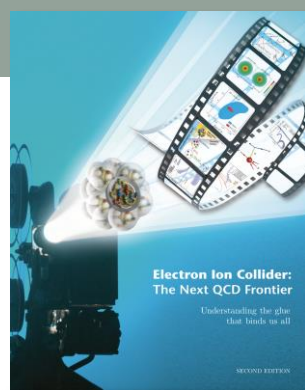

EIC moved forward.... A major step!

- DOE announced: January 9, 2020
 - **CD0 December 19, 2019**
 - **Site of EIC: Brookhaven National Laboratory**
- BNL and JLab realize EIC as partners
 - A formal EIC project is now setup at BNL
 - BNL+Jlab management & scientists
- **CD1 June 28, 2021**

- **CD2 Approval Early FY24**
- **CD3 Early FY2025 (start construction)**
- EIC CD4A Early Finish FY31
- EIC CD4 Physics Operation FY33



[Home](#) » U.S. Department of Energy Selects Brookhaven National Laboratory to Host Major New Nuclear Physics Facility

WASHINGTON, D.C. – Today, the **U.S. Department of Energy (DOE)** announced the selection of Brookhaven National Laboratory in Upton, NY, as the site for a planned major new nuclear physics research facility.

EIC moved forward....

CD0 December 2019 ; Site selection January 2020

BNL and JLab realize EIC as partners

- A formal EIC project is now setup at BNL
- BNL+Jlab management & scientists

CD1 in June 2021

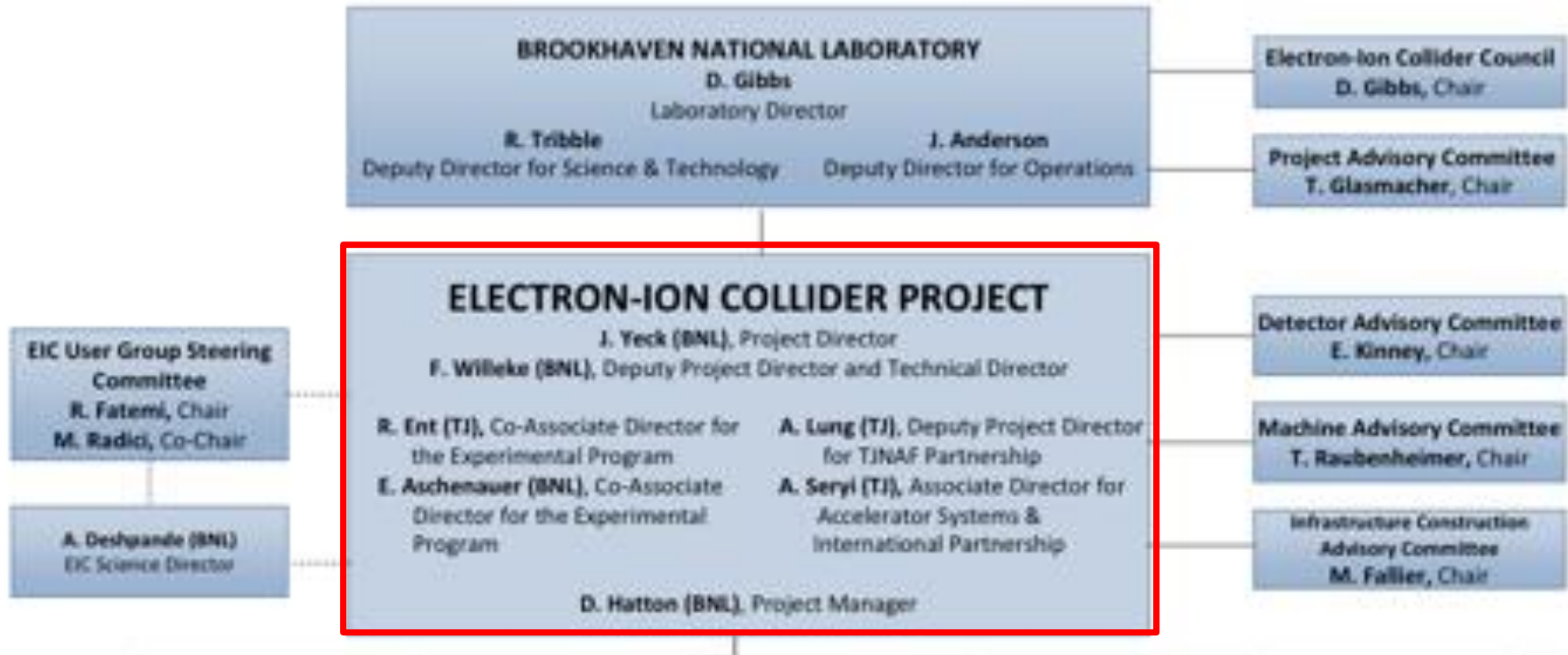
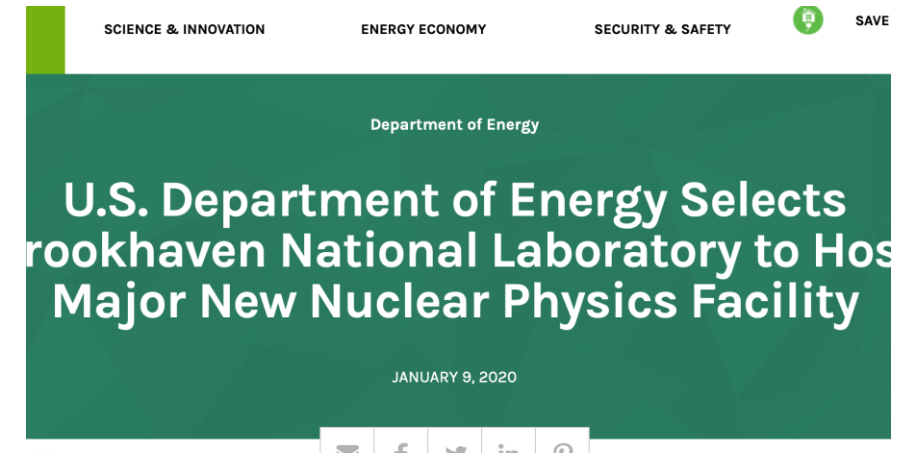

The US Electron Ion Collider

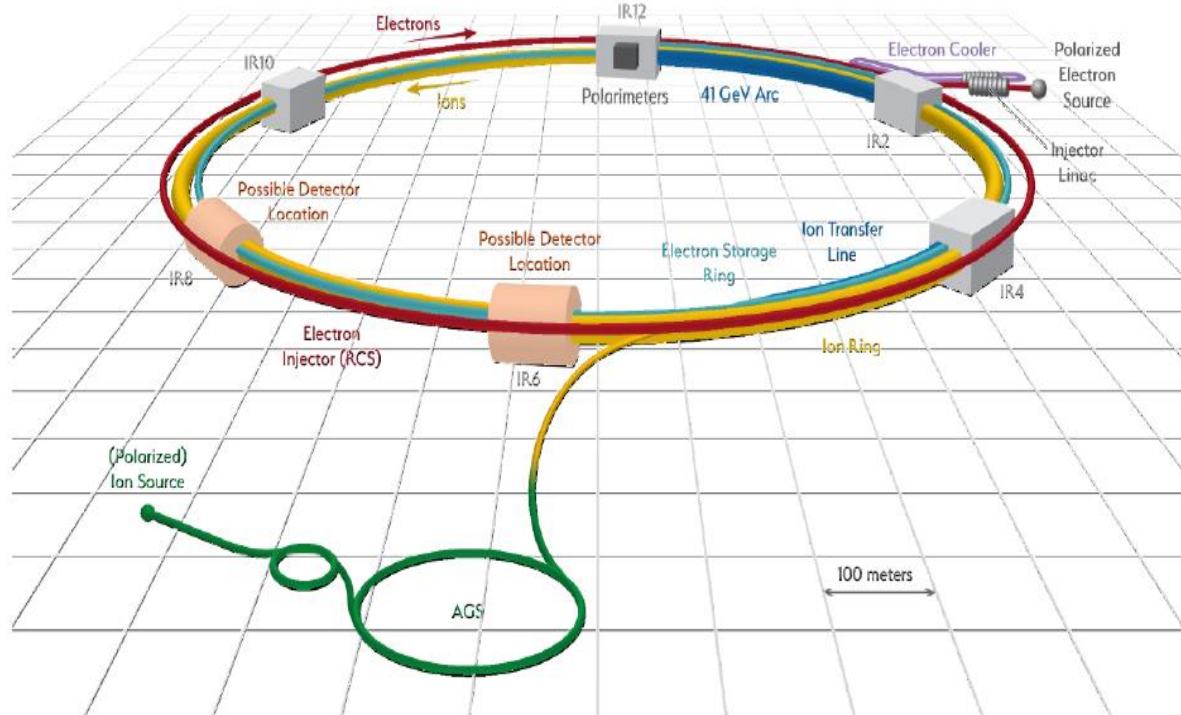
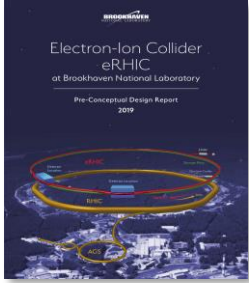

- ❖ Electron storage ring with frequent injection of fresh polarized electron bunches
- ❖ Hadron storage ring with strong cooling or frequent injection of hadron bunches

Hadrons up to 275 GeV

- Existing RHIC complex: Storage (Yellow), injectors (source, booster, AGS)
- Need few modifications
- RHIC beam parameters fairly close to those required for EIC@BNL

Electrons up to 18 GeV

- Storage ring, provides the range $\sqrt{s} = 20-140$ GeV. Beam current limited by RF power of 10 MW
- Electron beam with variable spin pattern (s) accelerated in on-energy, spin transparent injector (Rapid-Cycling-Synchrotron) with 1-2 Hz cycle frequency
- Polarized e-source and a 400 MeV s-band injector LINAC in the existing tunnel

Design optimized to reach $10^{34} \text{ cm}^{-2}\text{sec}^{-1}$

EIC Accelerator Design

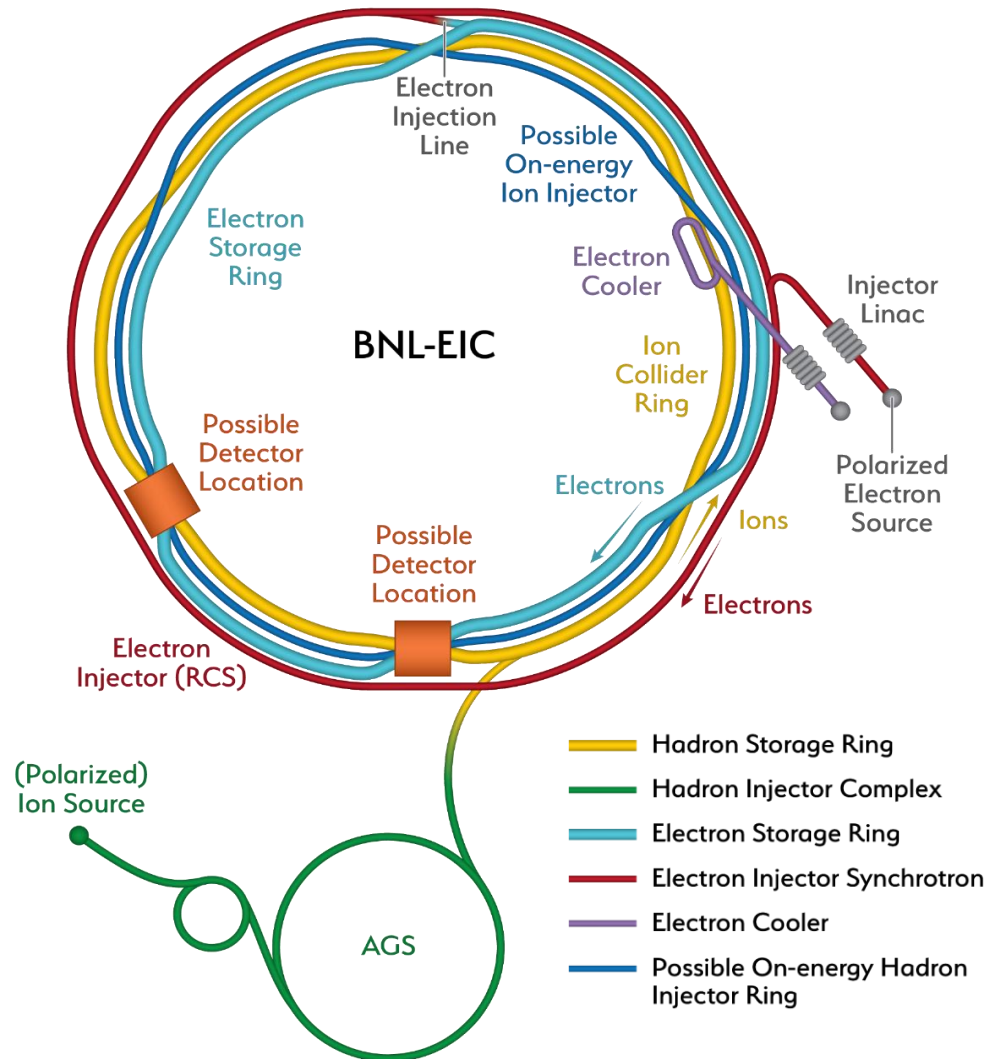

Center of Mass Energies:	20GeV - 140GeV
Luminosity:	$10^{33} - 10^{34} \text{ cm}^{-2}\text{s}^{-1}$ / 10-100fb ⁻¹ / year
Highly Polarized Beams:	70%
Large Ion Species Range:	p to U
Number of Interaction Regions:	Up to 2!

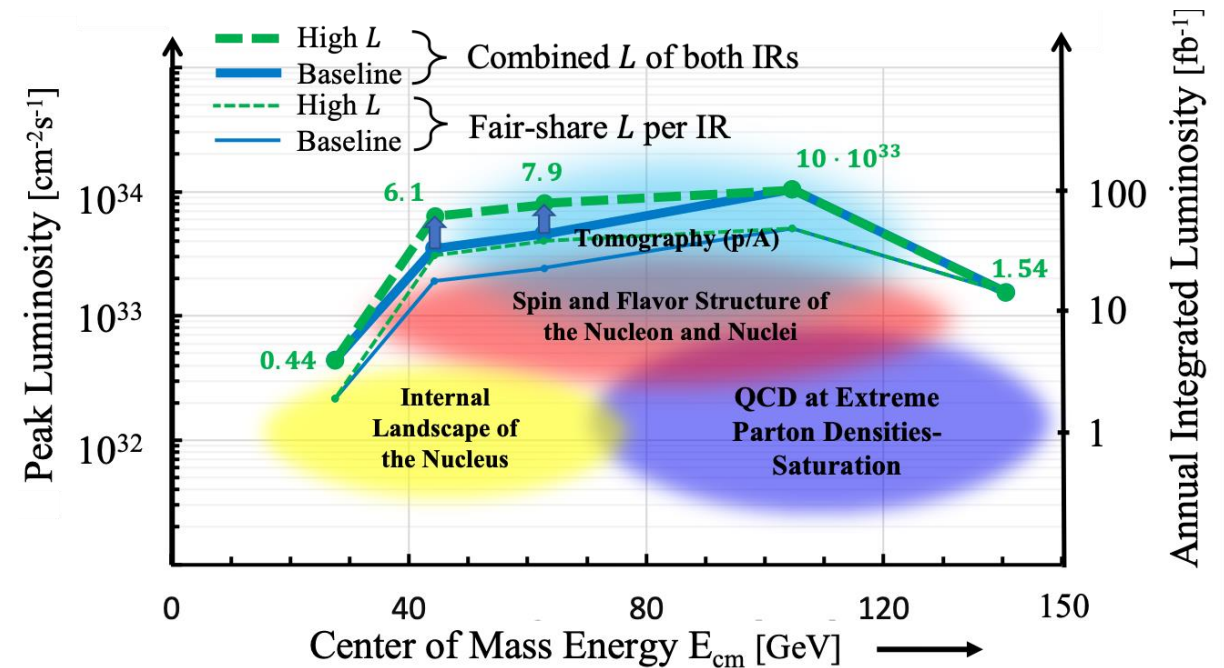

EIC: **NEW** Kinematic reach & properties

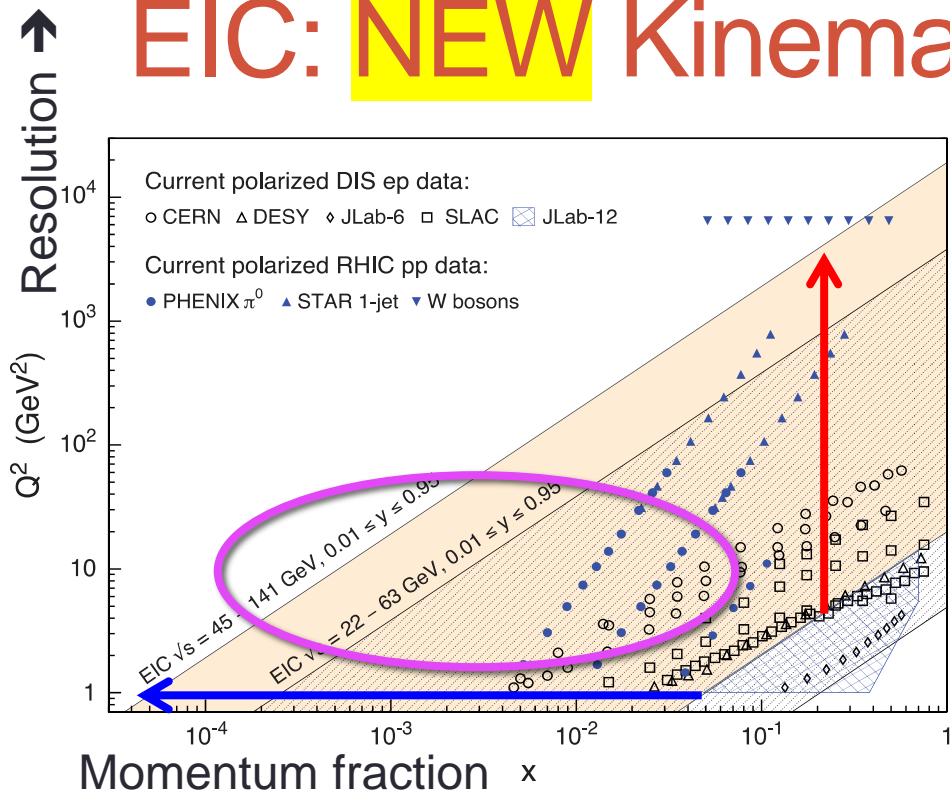
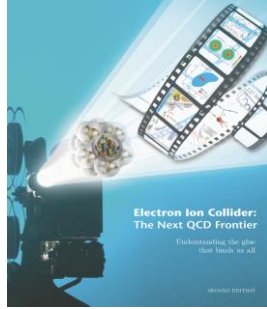

For e-N collisions at the EIC:

- ✓ Polarized beams: e, p, d/³He
- ✓ Variable center of mass energy
- ✓ **Wide Q^2 range \rightarrow evolution**
- ✓ **Wide x range \rightarrow spanning valence to low-x physics**

For e-A collisions at the EIC:

- ✓ Wide range in nuclei
- ✓ Luminosity per nucleon same as e-p
- ✓ Variable center of mass energy
- ✓ **Wide x range (evolution)**
- ✓ **Wide x region (reach high gluon densities)**

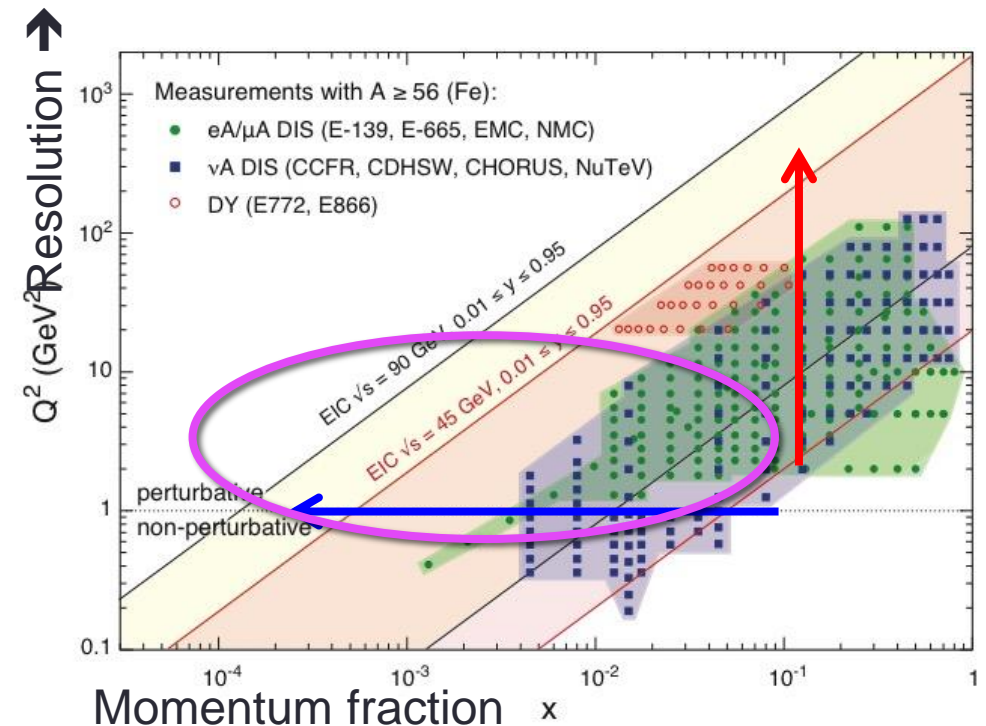

The EIC Users Group: [EICUG.ORG](https://www.eicug.org)

Formally established in 2016, now we have:
 ~1350+ Ph.D. Members from ~36 countries, 266 institutions
 New members welcome



New:
[Center for Frontiers in Nuclear Science](#) (at Stony Brook/BNL)
[EIC²](#) at Jefferson Laboratory

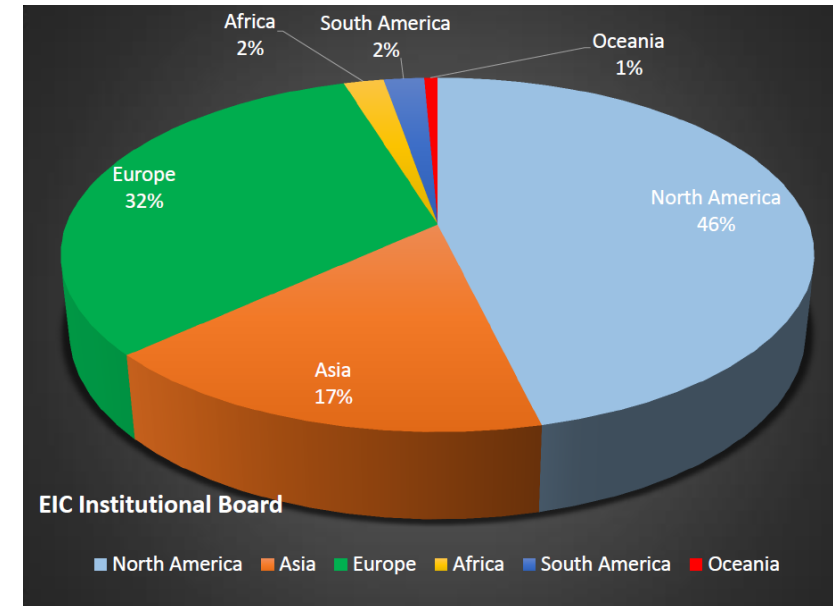

EICUG Structures in place and active:

EIC UG Steering Committee, Institutional Board, Speaker's Committee, Election & Nominations Committee

Year long workshops: [Yellow Reports for detector design](#)

Annual meetings: Stony Brook (2014), Berkeley (2015), ANL (2016), [Trieste \(2017\)](#), CAU (2018), [Paris \(2019\)](#), [FIU \(2020\)](#), [Remote \(2021\)](#), [Stony Brook \(2022, Hybrid\)](#), [Warsaw 2023](#)

Physics @ the US EIC beyond the EIC's core science

Perhaps other intersections
with LQCD?

Of HEP/LHC-HI interest to Snowmass 2021 (EF 05, 06, and 07 and possibly also EF 04)

New Studies with proton or neutron target:

- Impact of precision measurements of unpolarized PDFs at high x/Q^2 , on LHC-Upgrade results(?)
- Precision calculation of α_s : higher order pQCD calculations, twist 3
- Heavy quark and quarkonia (c, b quarks) studies with **100-1000 times lumi of HERA and with polarization**
- Polarized light nuclei in the EIC

Physics with nucleons and nuclear targets:

- Quark Exotica: 4,5,6 quark systems...? Much interest after recent **LHCb** led results.
- Physics of and with jets with EIC as a precision QCD machine:
 - Jets as probe of nuclear matter & Internal structure of jets : novel new observables, energy variability
 - Entanglement, entropy, connections to fragmentation, hadronization and confinement

Study of universality: e-p/A vs. p-A, d-A, A-A at RHIC and LHC

Precision electroweak and BSM physics:

- Electroweak physics & searches beyond the SM: Parity, charge symmetry, lepton flavor violation
- LHC-EIC Synergies: active MUON Detection with high purity – beyond current plans of “passive” identification

Concept DETECTOR

This detector concept was included in the EIC CDR prepared for the CD1 Review

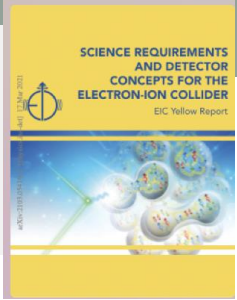

- Cherenkov
- Cryostat
- EmCal
- HCal
- HM RICH
- Preshower
- Si Tracker
- TOF
- TRACKER
- TRD

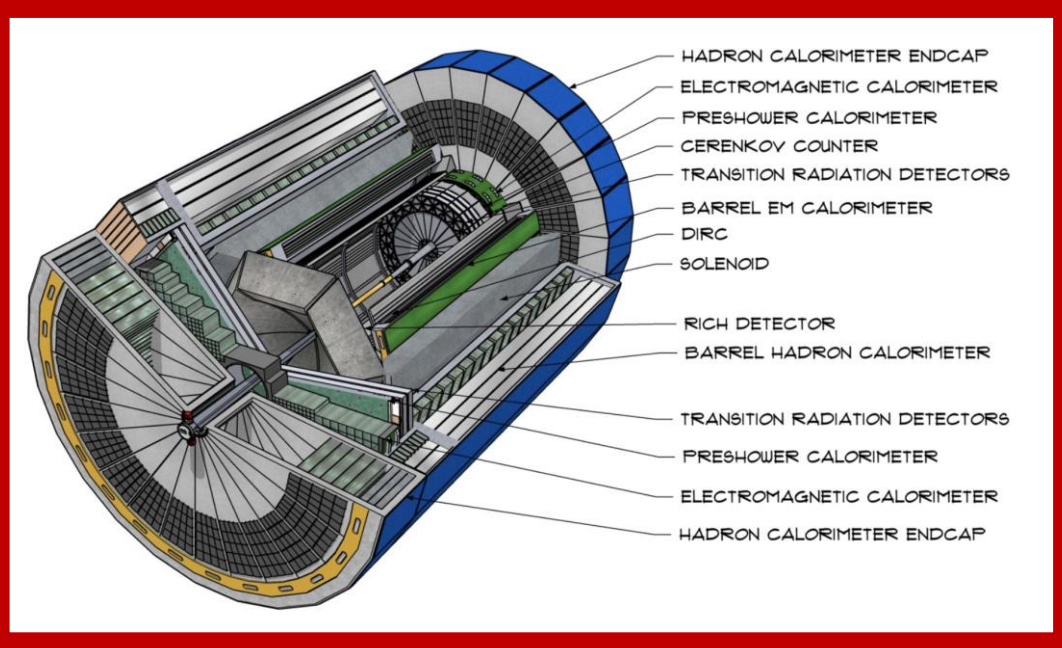
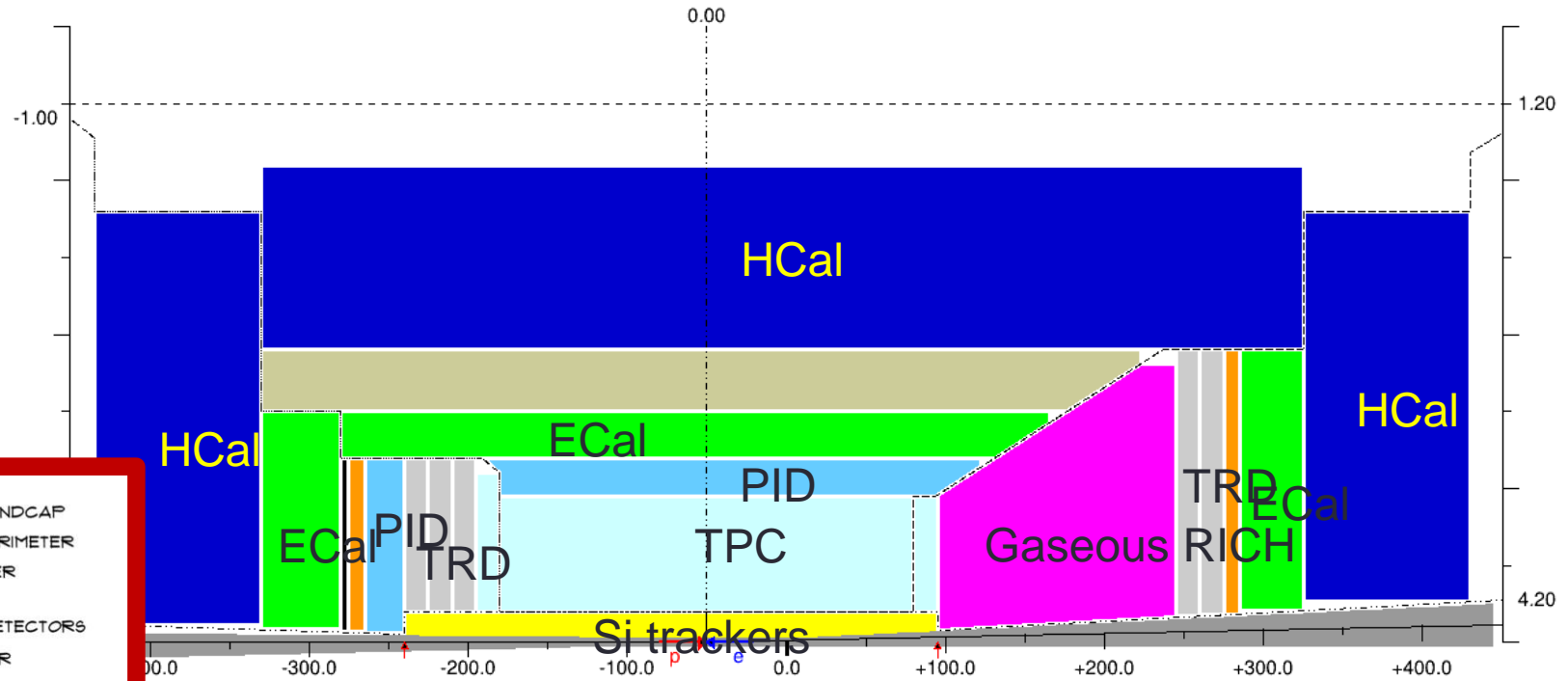

ATHENA (<https://sites.temple.edu/eicatip6/>)

- Focus on becoming the “project detector”@IP6
- New 3 T magnet and the YR Reference Detector
- Leadership: S. Dalla Torre (INFN Trieste, B. Surrow (Temple)
- ~117 collaborating institutions from Armenia, Canada, China, Czech, France, Germany, Italy, India, Poland, Romania, UK

CORE (<https://eic.jlab.org/core/>)

- An EIC Detector proposal based on a new 3 T compact magnet for the 2nd EIC detector @ IP8
- Contacts: Ch. Hyde (ODU) and P. Nadel-Turonski (SBU)
- Smaller-scale effort, ~20-30 active collaborators

ECCE (<https://www.ecce-eic.org>)

- Project detector @IP6 or the 2nd EIC detector @ IP8 using existing 1.5T “Babar” solenoid
- Leadership: O. Hen (MIT), T. Horn (CUA), J. Lajoie (Iowa State)
- ~98 collaborating institutions from Armenia, Canada, Chile, China, Croatia, Czech, France, Germany, Israel, Japan, Senegal, Korea, Russia, Slovenia, Taiwan, UK

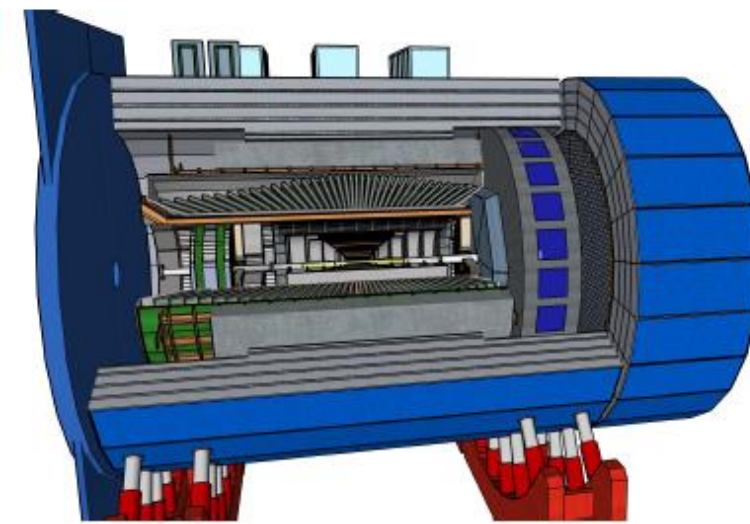
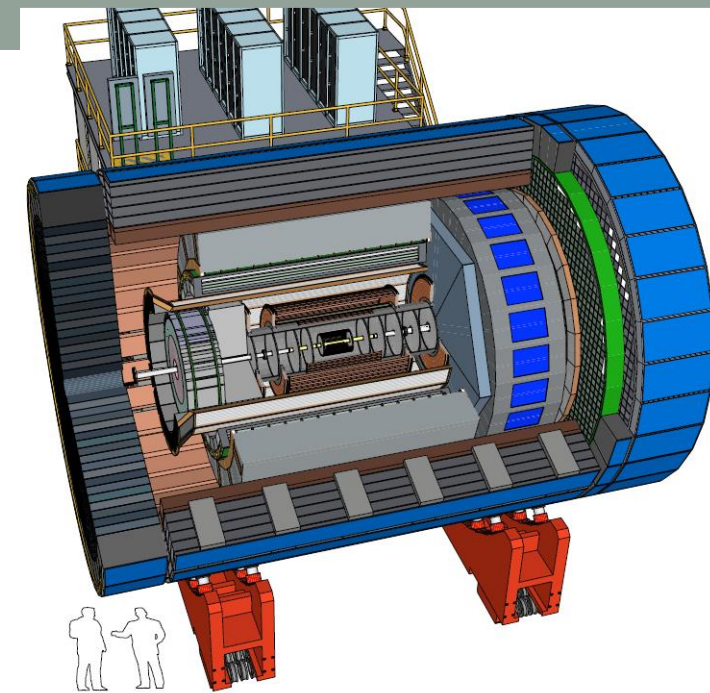
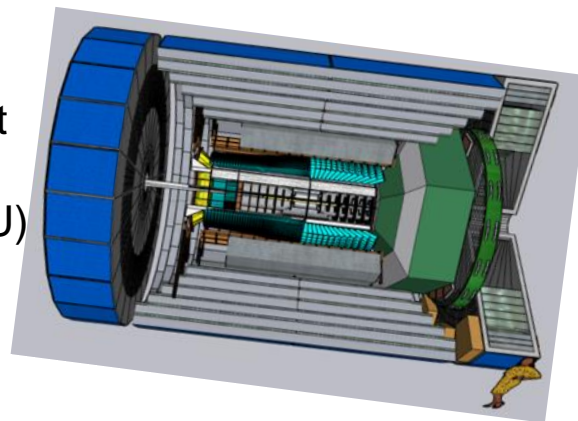

Detector Proposal Advisory Panel → Emergence of EPIC

- All three proposals received high marks
- Concluded that both ATHENA and ECCE satisfied the requirements
- Recommended **ECCE proposal as the reference detector: lower risk and cost**
 - Many collaborators are involved in multiple proposals and none of the proto-collaborations strong enough to build the project detector
 - Strongly encouraged the three proto-collaborations to merge and build the project detector starting from ECCE's reference design
- Suggested integration of collaborations to realize new experimental concepts & technologies starting with the concept of ECCE & realize the EIC project detector → **As of July 2022 : Electron Proton Ion Collider (EPIC) Detector as close as possible to the reference detector.**
- Enthusiastically supported a **second detector**
 - EIC User Community should think of the project detector & **a second detector**

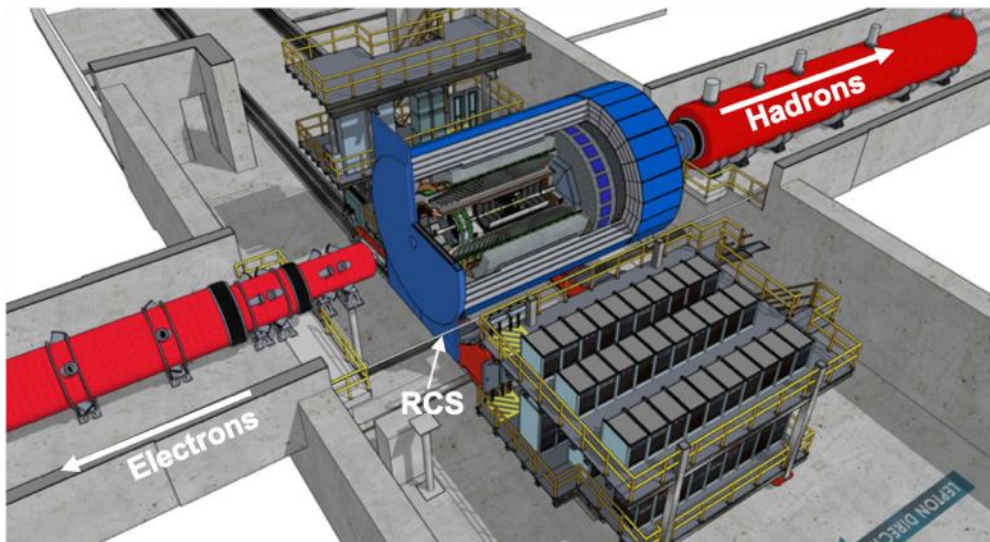
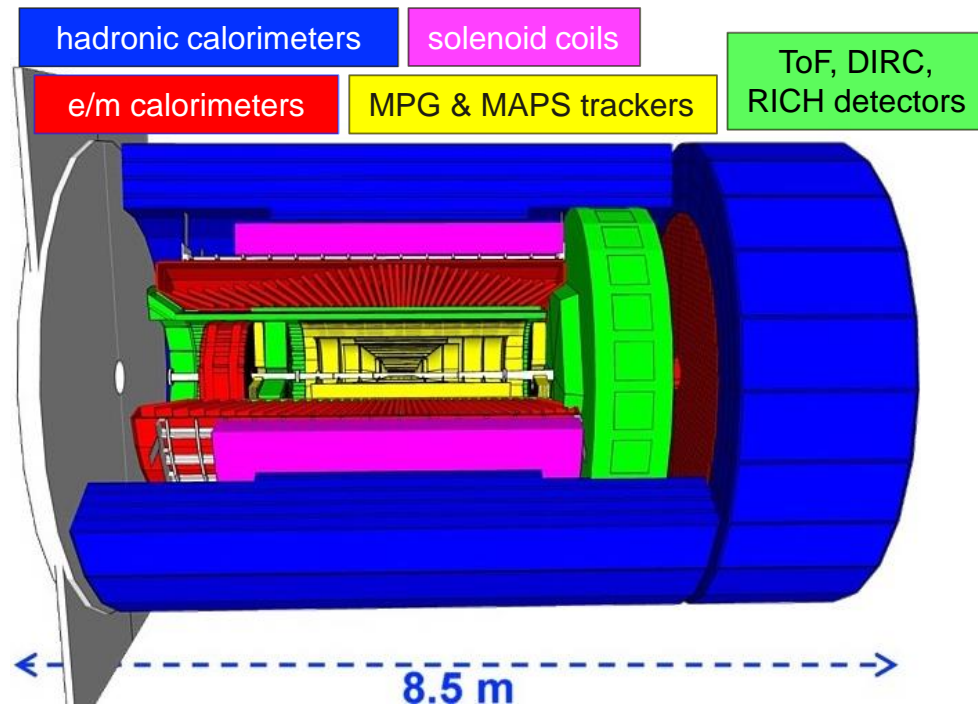

Experimental Equipment: EPIC

Overall detector requirements:

- ❑ Large rapidity ($-4 < \eta < 4$) coverage; and far beyond
 - Large acceptance for diffraction, tagging, neutrons from nuclear breakup: critical for physics program
 - Integration into IR from the beginning critical
 - Many ancillary detector along the beam lines: low- Q^2 tagger, Roman Pots, Zero-Degree Calorimeter,
- ❑ High precision low mass tracking
 - small (μ -vertex Silicon) and large radius (gas-based) tracking
- ❑ Electromagnetic and Hadronic Calorimetry
 - equal coverage of tracking and EM-calorimetry
- ❑ High performance PID to separate e , π , K , p on track level
 - good e/h separation critical for scattered electron ID
- ❑ Maximum scientific flexibility
 - Streaming DAQ → integrating AI/ML
- ❑ Excellent control of systematics
 - luminosity monitor, electron & hadron Polarimetry

THE HIGH ENERGY PHYSICS CONNECTION

Kick-off meeting at CERN: <https://indico.ph.tum.de/event/7014/>

Activity in the US: Snowmass 2021-2022 Workshop

EIC Science from the Perspective of HEP: [arXiv:2203.13199v1](https://arxiv.org/abs/2203.13199v1)

The **Standard Model of physics** would not have been possible without many decades of **synergetic & complimentary** measurements amongst:

- e-e, e-p, p-p/pbar scattering around the world
- LEP, SLAC, KEK, TEVTRON, SpS, HERA and recently RHIC, CEBAF & LHC.



It is only natural that this quest for understanding nature continues in the future for **precision QCD, (EW, Beyond SM physics)** with the prospect of

- the Electron Ion Collider (EIC), LHC upgrades including the luminosity increase and future lepton-hadron machines, higher energy e-e, hadron and muon colliders

Start of the discussion of synergies between the EIC and the LHC in the context of the Long-Range Planning exercises both in the US (Snowmass 2021/2) and Europe (NuPECC) – recent meeting at CERN

EIC's versatility, resolving power and intensity (luminosity) open new windows of opportunity to address some of the crucial and fundamental scientific questions in particle physics. The paper summarizes the EIC physics from the perspective of the HEP community participating in **Snowmass 2021**

[arXiv:2203.13199v1](https://arxiv.org/abs/2203.13199v1)

- Beyond the Standard Model Physics at the EIC
 - Tomography (1,3,5 d PDFs) of Hadrons and Nuclei at the EIC
 - Jets at EIC
 - Heavy Flavors at EIC
 - Small-x Physics at the EIC
-
- High luminosity wide CM range
 - Polarized e, p, and ion beams
 - All nuclei

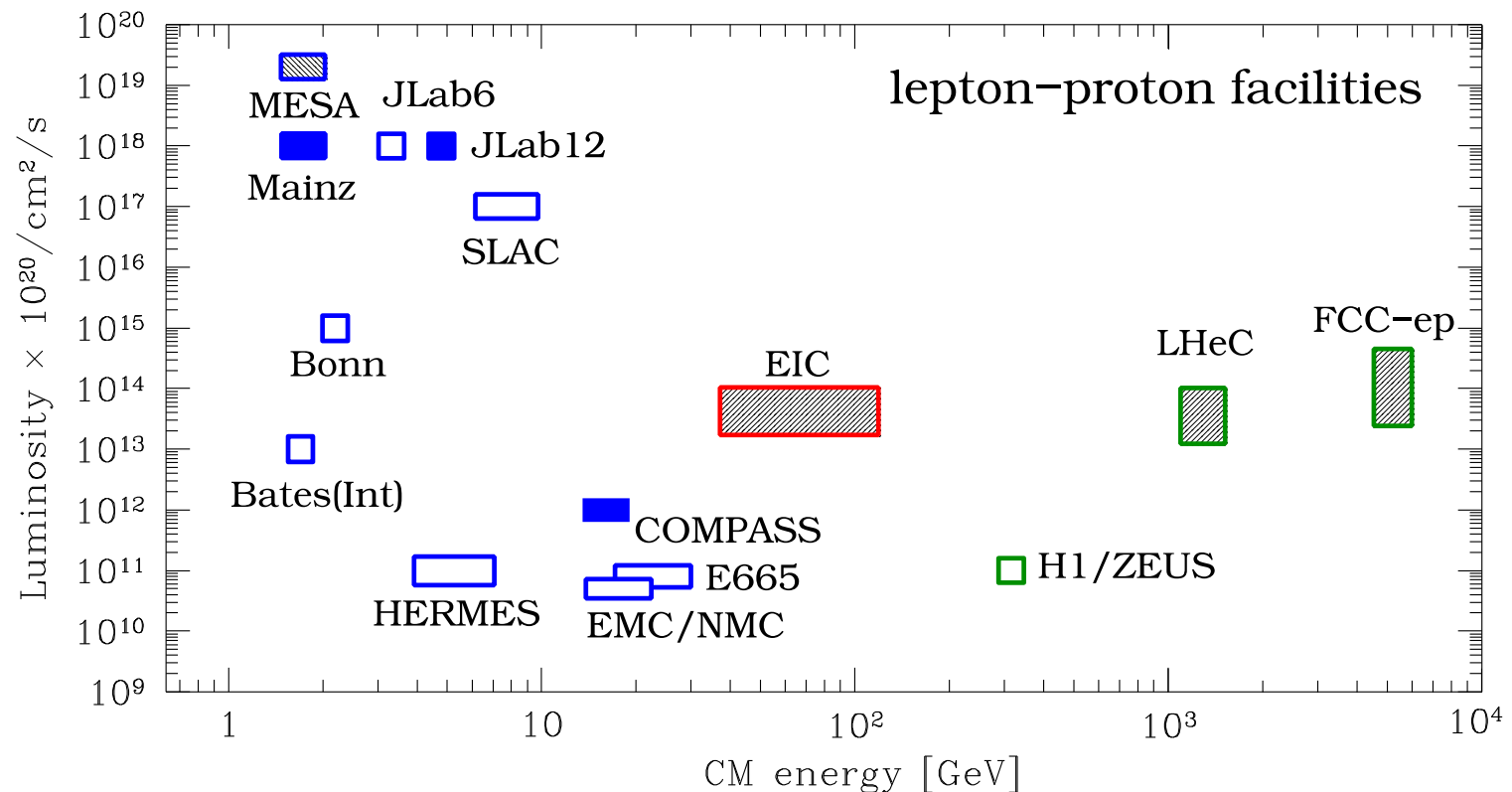

Detector technologies EIC & LHC:

Potential for overlap and collaboration:

Many EIC collaborators already part of RD51 (and family) at CERN & vice-versa.

- MAPS μ Vertex for primary/secondary vtx: barrel & end-caps (ALICE ITS3)
- Micro Pattern Gas Detectors: large rapidity, spatial resolution $\sim 100 \mu\text{m}$
- Electromagnetic Calorimetry for kinematic reconstruction, precise energy measurements e, γ ; e/π & π^0/γ separation. Various technologies at various locations:
 - W/SciFi w/o PMT, PbWO₄, SiGlass; AstroPix & Pb/SciFi
 - High resolution Crystal Cal for e-endcap
 - Barrel EMCal 6 layers AstroPix and Pb/SciFi
- Particle Identification – extremely important for most EIC physics
 - K/pi separation over a wide range 1-20 GeV/c
 - Hadron ID: hpDIRC in Barrel, forward EndCap: dual RICH, backward Endcap: modular RICH or pF RICH, also TOF for short lever arm : LGAD, LAPPD
- Streaming Readout

EIC an International Partnerships

- EIC is planned to be an international project
 - Collaboration on EIC design and construction –mutually beneficial, advancing accelerator science and technology and providing a gateway to EIC science
- Possible contributions to the EIC accelerator could include the full range of accelerator design and hardware
 - Examples: IR magnet design and construction, luminosity monitoring, RF R&D and construction, normal conducting magnets, critical vacuum components, feedback systems, polarimetry, contributions to the 2nd IR, beam-dynamics calculations, etc.
- Detector will be constructed via international collaborations, with substantial contribution from partners
 - Detector christened EPIC
 - Detailed contributions to EPIC *now under discussions* with EIC management
 - Contracts between US DOE and international funding agencies also underway

Overall Schedule

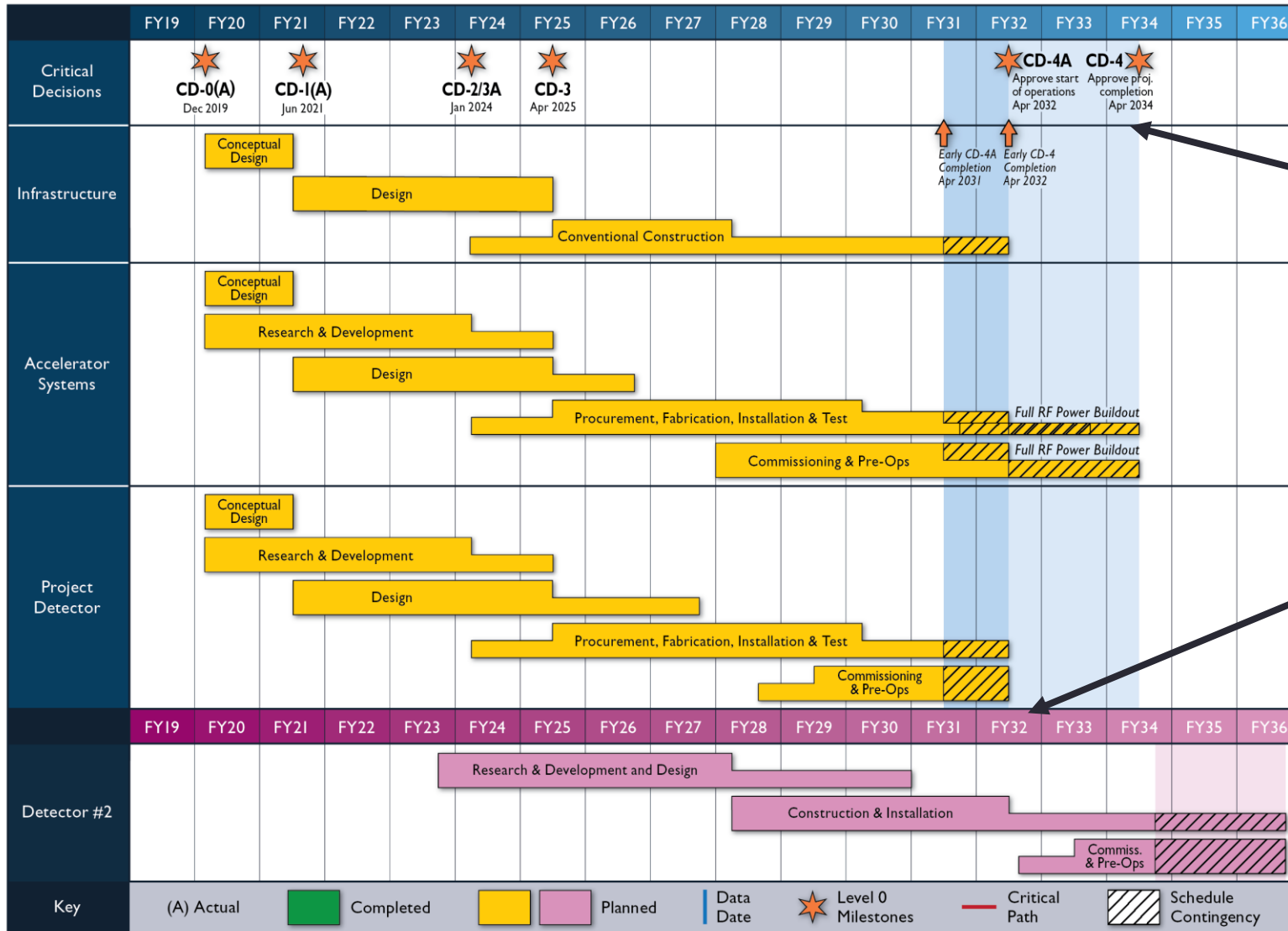

CD4A early finish, collisions begin for machine tuning
 Detector 1 needs to be ready to give feedback.

CD4 Machine delivers for physics
 Detector 1 should be fully functional to start physics

2nd Detector and IR

- Current assumption realization trailing ~3 – 5 years behind EIC Detector-1
- focus on complementary physics & technologies for 2nd Detector

Outlook

- Electron Ion Collider, a high-energy **high-luminosity polarized e-p, e-A collider**, will be built in this decade and operate in 2030's. Excellent Science potential!
- Up to two hermetic (full acceptance? and yet complementary) detectors under consideration. **Cost of a second detector to be determined and sources identified**
- An aggressive timeline
- **High interest in international partnership on detector and accelerator**

- **For all early career scientists, graduate and undergraduate students: This machine is for you! Ample opportunity to contribute to machine, detector & physics of a new project.**

EIC planned time-line: (subject to modifications)

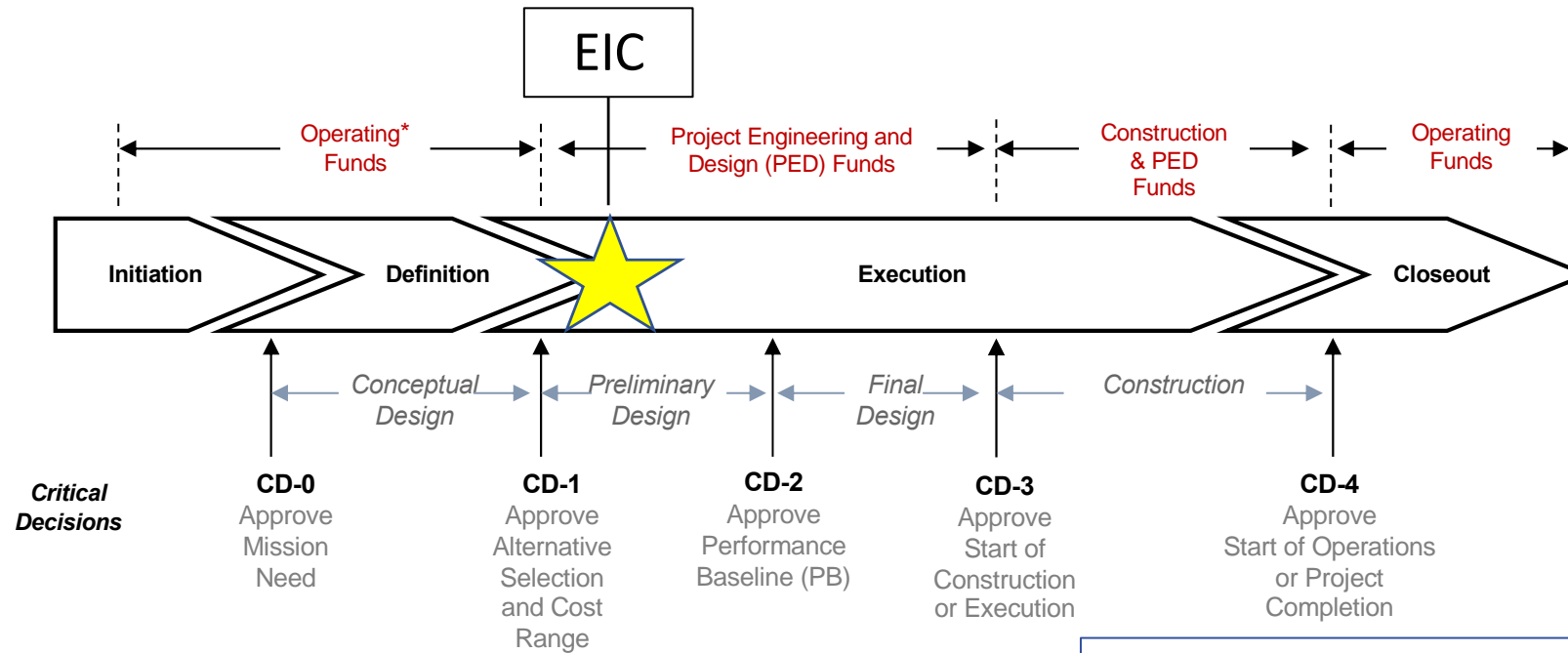

Gateway Reviews

- *CD-0, Mission Need*
- *CD-1, Alternative Selection and Cost Range*
- **CD-2, Performance Baseline**
- **CD-3a, Long Lead Procurement**

EIC Critical Decision Plan at CD-1*

CD-2/3a	April 2023
CD-3	July 2024
CD-4a early finish	July 2030
CD-4a	July 2031
CD-4 early finish	July 2031
CD-4	July 2033

Complementarity for 1st-IR & 2nd-IR

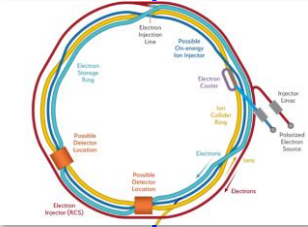
	1 st IR (IP-6)	2 nd IR (IP-8)
Geometry:	<p>ring inside to outside</p> <p>tunnel and assembly hall are larger</p> <p>Tunnel: \varnothing 7m +/- 140m</p>	<p>ring outside to inside</p> <p>tunnel and assembly hall are smaller</p> <p>Tunnel: \varnothing 6.3m to 60m then 5.3m</p>
Crossing Angle:	25 mrad	35 mrad secondary focus
		
	<p>different blind spots</p> <p>different forward detectors and acceptances</p> <p>different acceptance of central detector</p>	
Luminosity:	<p>more luminosity at lower E_{CM}</p> <p>optimize Doublet focusing FDD vs. FDF</p> <p>→ impact of far forward p_T acceptance</p>	
Experiment:	<p>1.5 Tesla or 3 Tesla</p> <p>different subdetector technologies</p>	

Potential Accelerator Contributions

- Italy, INFN
 - HSR vacuum chamber inserts
- Canada, TRIUMF
 - SC Crab Cavity system
 - Pulsed systems
- UK, ASTEC & Cockcroft Inst.
 - ERL components
- France, IJCLab
 - SHC ERL diagnostics
- France, CEA Saclay
 - IR SC magnets
 - SC spin rotators
- CERN, Switzerland
 - ESR SC cryomodule joint design
 - ESR high current elements joint design
- Japan, KEK
 - ESR collimation system



High level readiness of technical status
Possibly, first case for use of seed funds



High level readiness of technical status

Project is developing possibility of “Seed” funds for EIC international collaboration that can enable early start of EIC accelerator design efforts in partner countries

- Recent & tentative:
 - Israel, SARAF
 - RF power amplifiers
 - Collimators, controls
 - Sweden, Uppsala Uni.
 - SSPA

EIC Science from the perspective of High Energy Physicists

arXiv:2203.13199v1 [hep-ph] 24 March 2022

Snowmass 2021 White Paper: Electron Ion Collider for High Energy Physics

R. Abdul Khalek,¹ U. D'Alesio,^{2,3} Miguel Arratia,^{4,5,*} A. Bacchetta,⁶ M. Battaglieri,^{7,1} M. Begel,⁸ M. Boglione,⁹ R. Boughezal,¹⁰ Renaud Boussarie,^{11,*} G. Bozzi,^{12,3} S. V. Chekanov,¹⁰ F. G. Celiberto,^{13,14,15} G. Chirilli,¹⁶ T. Cridge,¹⁷ R. Cruz-Torres,¹⁸ R. Corliss,^{19,20} C. Cotton,²¹ H. Davoudiasl,⁸ A. Deshpande,^{8,19} Xin Dong,^{18,*} A. Emmert,²¹ S. Fazio,⁸ S. Forte,²² Yulia Furletova,^{1,*} Ciprian Gal,^{23,20,*} Claire Gwenlan,^{24,*} V. Guzey,²⁵ L. A. Harland-Lang,²⁶ I. Helenius,^{27,28} M. Hentschinski,²⁹ Timothy J. Hobbs,^{30,31,*} S. Höche,³² T.-J. Hou,³³ Y. Ji,¹⁸ X. Jing,³⁴ M. Kelsey,^{35,18} M. Klasen,³⁶ Zhong-Bo Kang,^{37,38,20,*} Y. V. Kovchegov,³⁹ K.S. Kumar,⁴⁰ Tuomas Lappi,^{27,28,*} K. Lee,^{41,42} Yen-Jie Lee,^{43,44,*} H.-T. Li,^{45,46,47} X. Li,⁴⁸ H.-W. Lin,⁴⁹ H. Liu,⁴⁰ Z. L. Liu,⁵⁰ S. Liuti,²¹ C. Lorcé,⁵¹ E. Lunghi,⁵² R. Marcarelli,⁵³ S. Magill,⁵⁴ Y. Makris,⁵⁵ S. Mantry,⁵⁶ W. Melnitchouk,¹ C. Mezzag,⁵⁷ S. Moch,⁵⁸ H. Moutarde,⁵⁷ Swagato Mukherjee,^{8,†} F. Murgia,³ B. Nachman,^{59,60} P. M. Nadolsky,⁶¹ J.D. Nam,⁶² D. Neill,⁶³ E.T. Neill,⁵³ E. Nocera,⁶⁴ M. Nycz,²¹ F. Olness,⁶¹ F. Petriello,^{46,47} D. Pitonyak,⁶⁵ S. Plätzer,⁶⁶ Stefan Prestel,^{67,*} Alexei Prokudin,^{68,1,*} J. Qiu,¹ M. Radici,⁶ S. Radhakrishnan,^{69,18} A. Sadofyev,⁷⁰ J. Rojo,^{71,72} F. Ringer,^{73,19} Farid Salazar,^{37,38,74,75,*} N. Sato,¹ Björn Schenke,^{8,*} Sören Schlichting,^{76,*} P. Schweitzer,⁷⁷ S. J. Sekula,^{78,*} D. Y. Shao,⁷⁹ N. Sherrill,⁸⁰ E. Sichtermann,¹⁸ A. Signori,⁶ K. Şimşek,⁸¹ A. Simonelli,⁹ P. Sznajder,⁸² K. Tezgin,⁸³ R. S. Thorne,¹⁷ A. Tricoli,⁸ R. Venugopalan,⁸ A. Vladimirov,⁸⁴ Alessandro Vicini,^{22,*} Ivan Vitev,^{85,*} D. Wiegand,⁸⁶ C.-P. Wong,⁴⁸ K. Xie,⁸⁷ M. Zaccheddu,^{2,3} Y. Zhao,⁸⁸ J. Zhang,⁸⁹ X. Zheng,²¹ and P. Zurita⁸⁴