

The MARTA project in AugerPrime: RPCs to detect muons in the Pampa

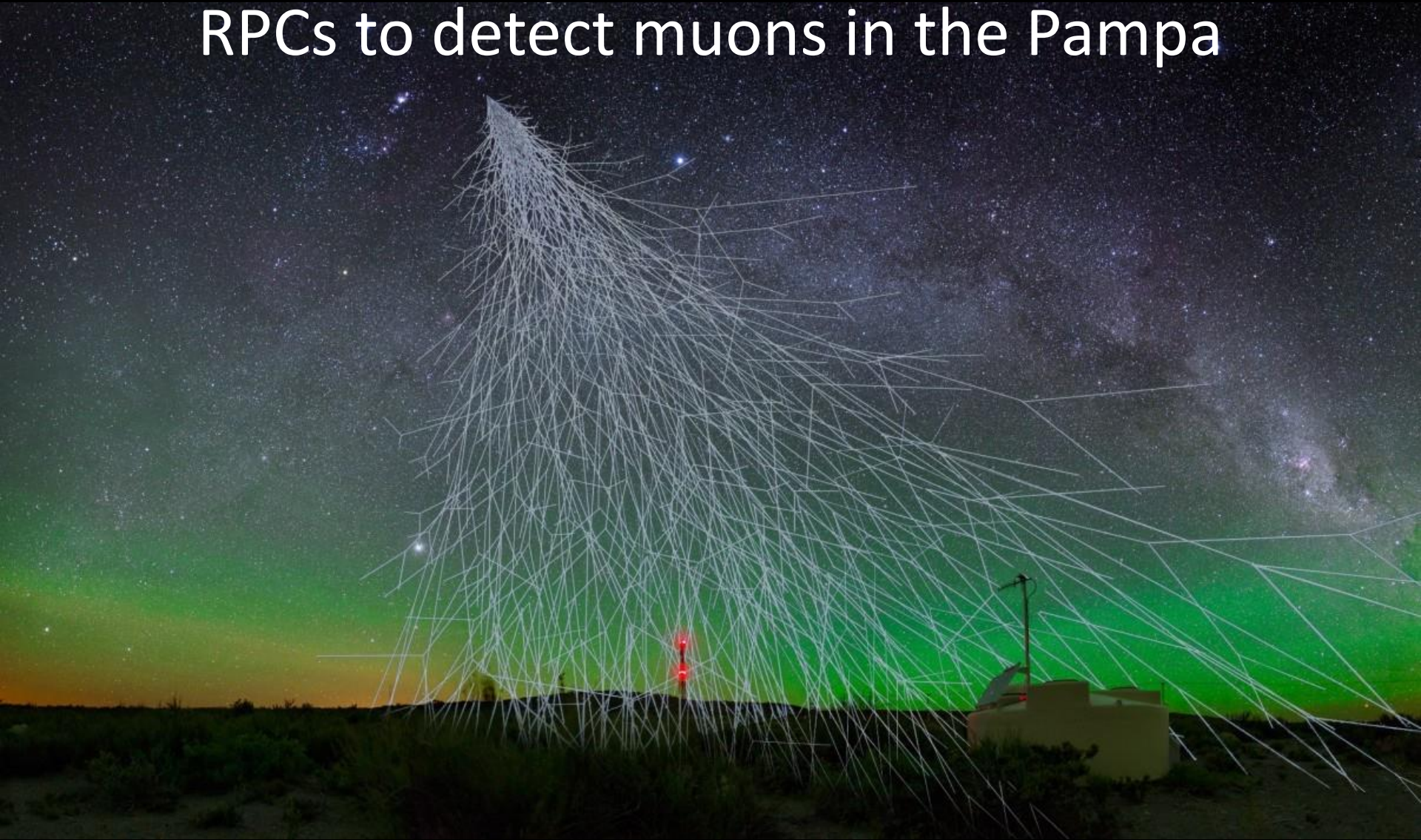

Extended Air Showers

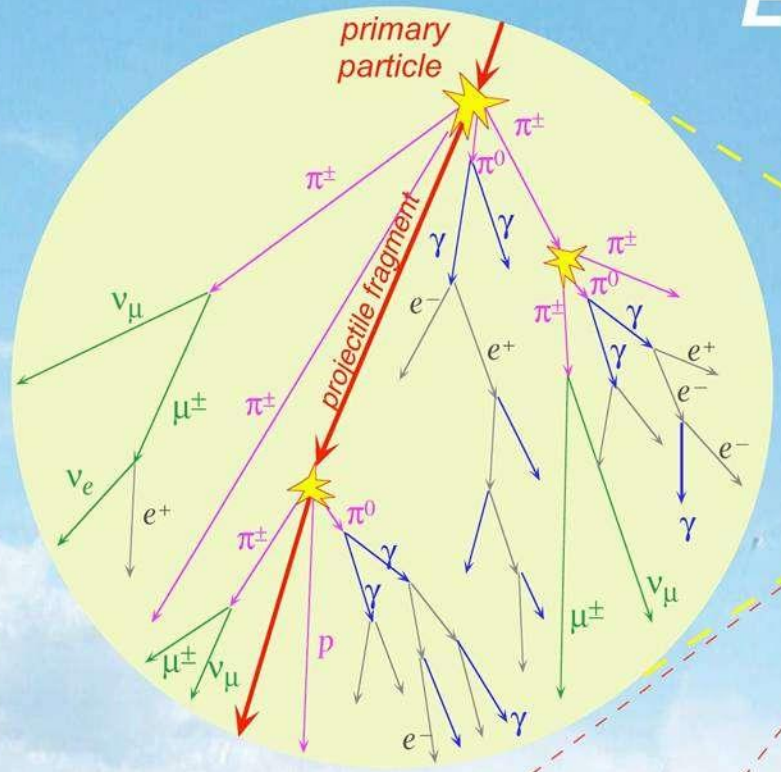

primary particle

Pierre Auger Observatory:
 $10^{19} \text{ eV} < E < 10^{21++} \text{ eV}$

Trajektorie

Cherenkov light

Fluorescence light - isotropic

1 m thickness

$\gamma \approx c$

Electronic
Schmidt telescope

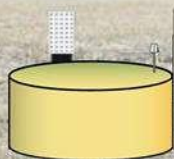
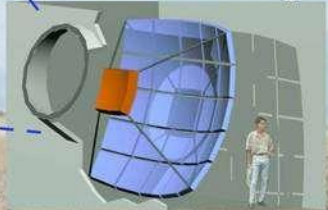

Water-Cherenkov detectors

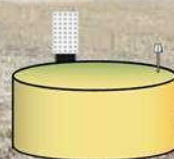
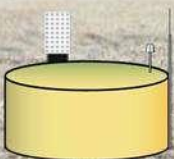

1,5 km

Fluorescence
Detector
↓

Water
Cherenkov
Detector
↓

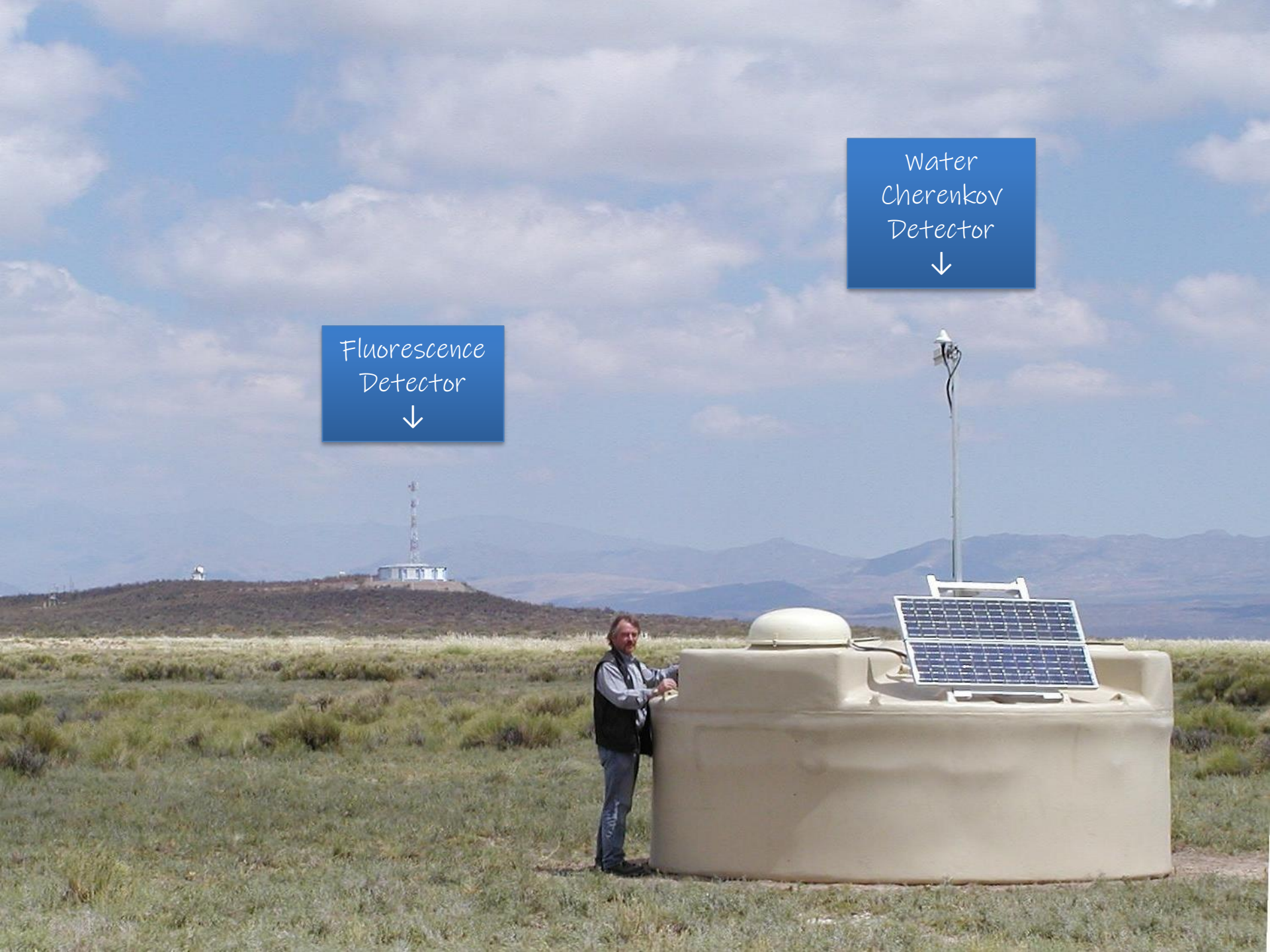

Making precision measurements to shed light on what's the muon content

The muons “problem”

“number” of muons
Measured by tanks

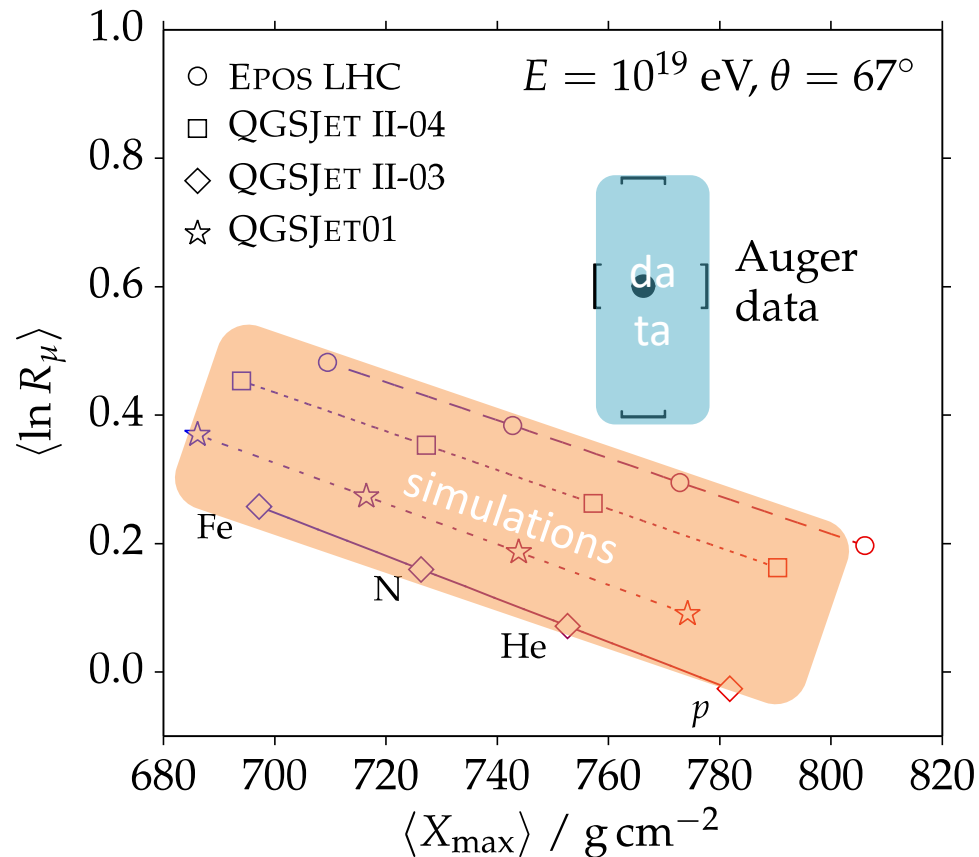

Depth of shower – Measured by FD



GAP2013-020

MARTA
Muon Auger RPC for the Tank Array
Design Report

V1.0

GAP2013-XXX

MARTA
Muon Auger RPC for the Tank Array
1st Progress Report

CBPF - Centro Brasileiro de Pesquisas Físicas, Brazil

FZU - Institute of Physics, Czech Academy of Sciences, Czech Republic

IFSC/USP - Instituto de Física de S. Carlos, Universidade de S. Paulo, Brazil

LIP - Laboratório de Instrumentação e Partículas, Portugal

UNICAMP - Universidade Estadual de Campinas, Brazil

UFRJ - Universidade Federal do Rio de Janeiro, Brazil

Università di Roma II, "Tor Vergata", Italy

Università di Napoli, "Federico II" and INFN, Napoli

USC - Universidade de Santiago de Compostela, Spain

with the collaboration of
Peter Mazur and Alan Watson

27 May 2013

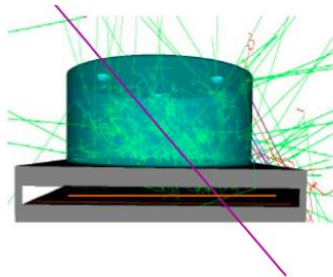

Baseline configuration

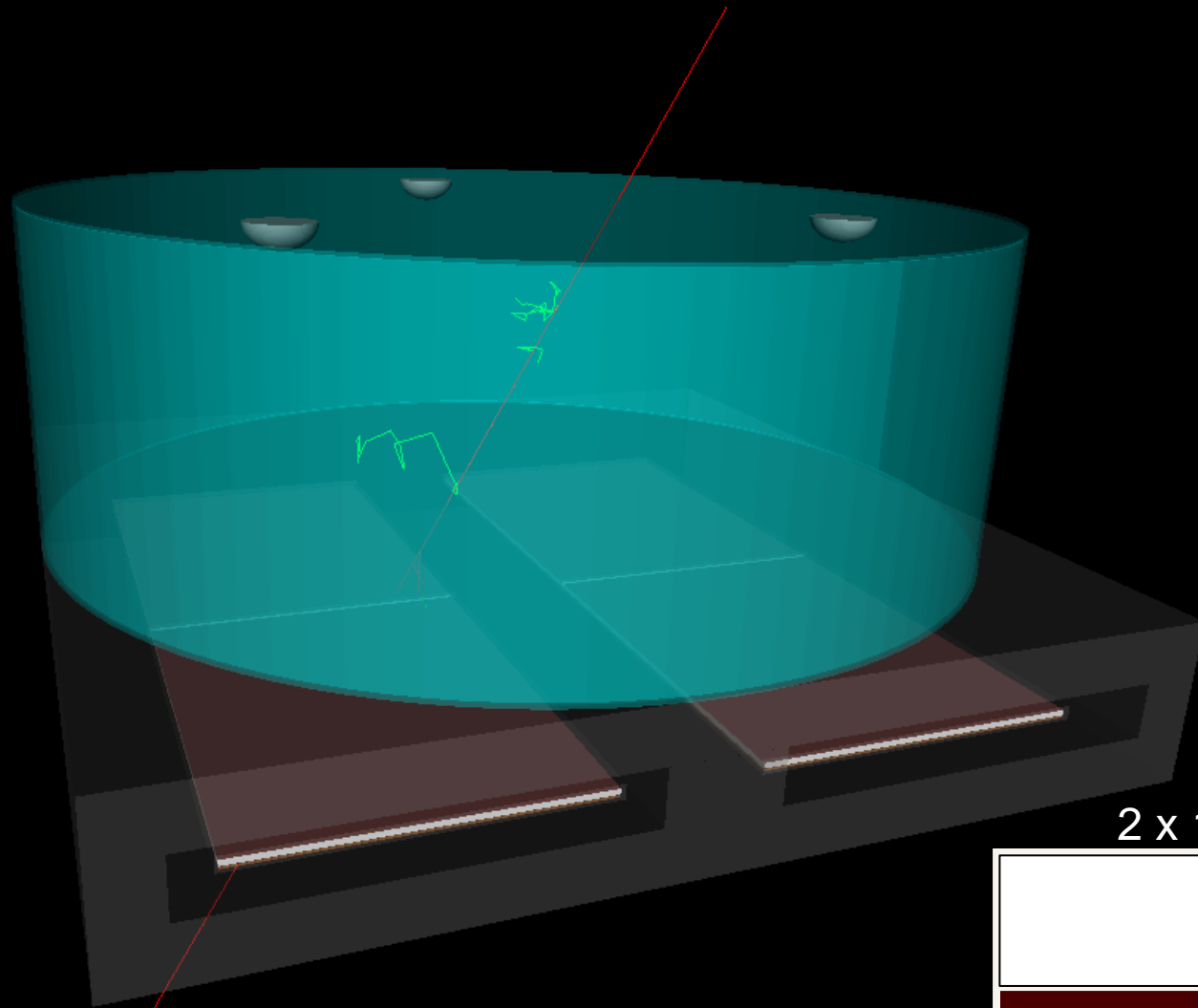

4 x (1.5 m x 1.2 m) RPC

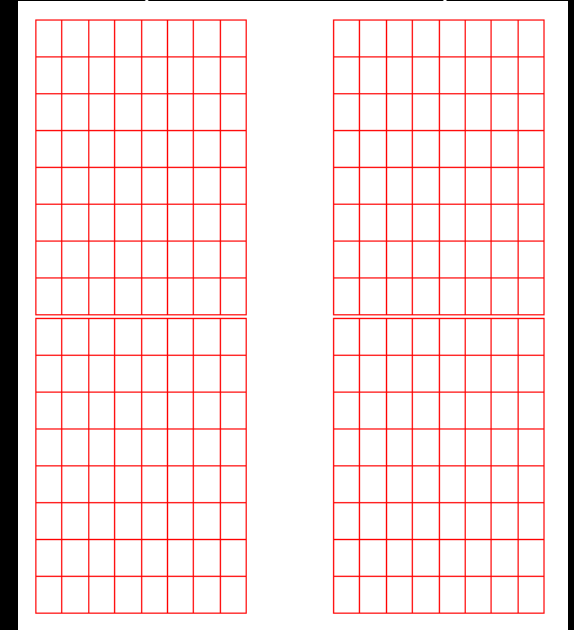

8x8 pads each RPC

Concrete precast : 20 cm thick ($\sim 50 \text{ g/cm}^2$)

2 x 1 mm gas gap RPC inside Al ca



Punch-through

- “only muons reach the RPCs”
- Some parts of the RPC are more “exposed”
 - Segmented readout allows to create e.m. contamination maps
 - Dynamically define a fiducial area (shower to shower, dependent on station-shower distance)
 - Only pads with e.m. contamination below predefined threshold are used
 - Allows for muon measurement with small bias from e.m. component

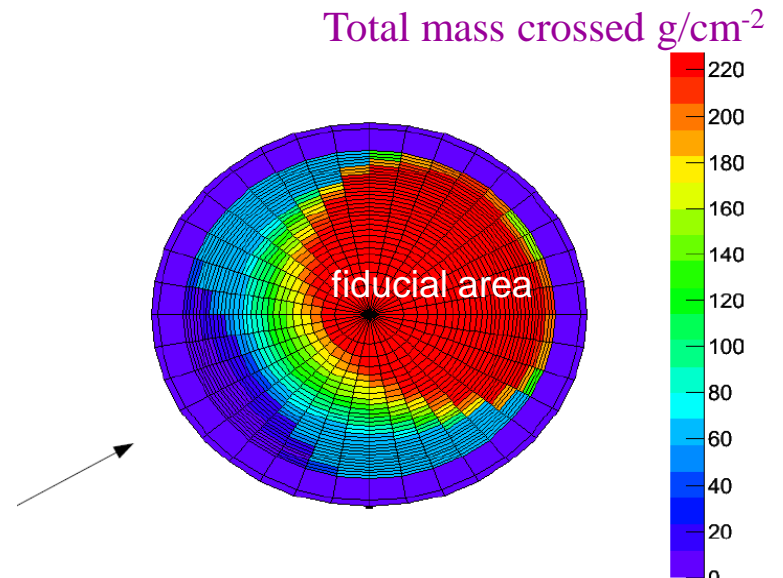
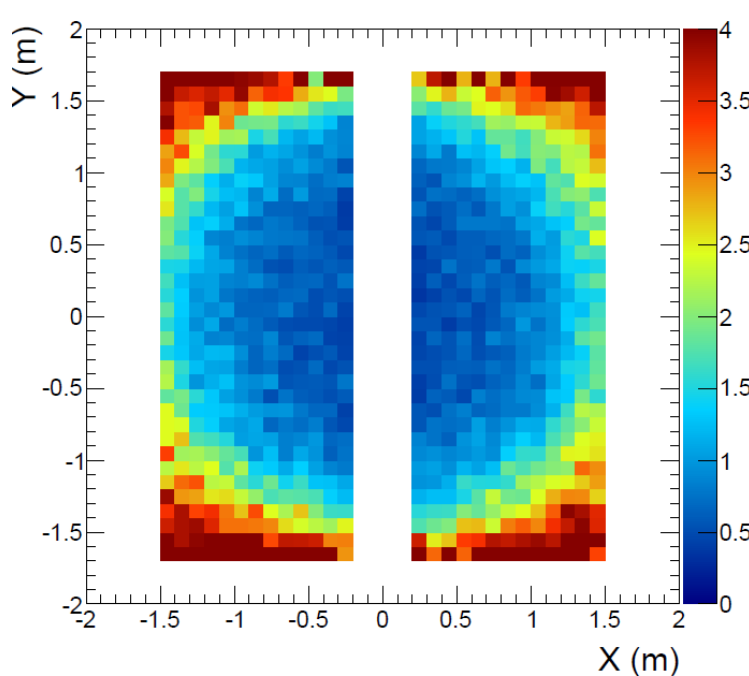



MARTA EA

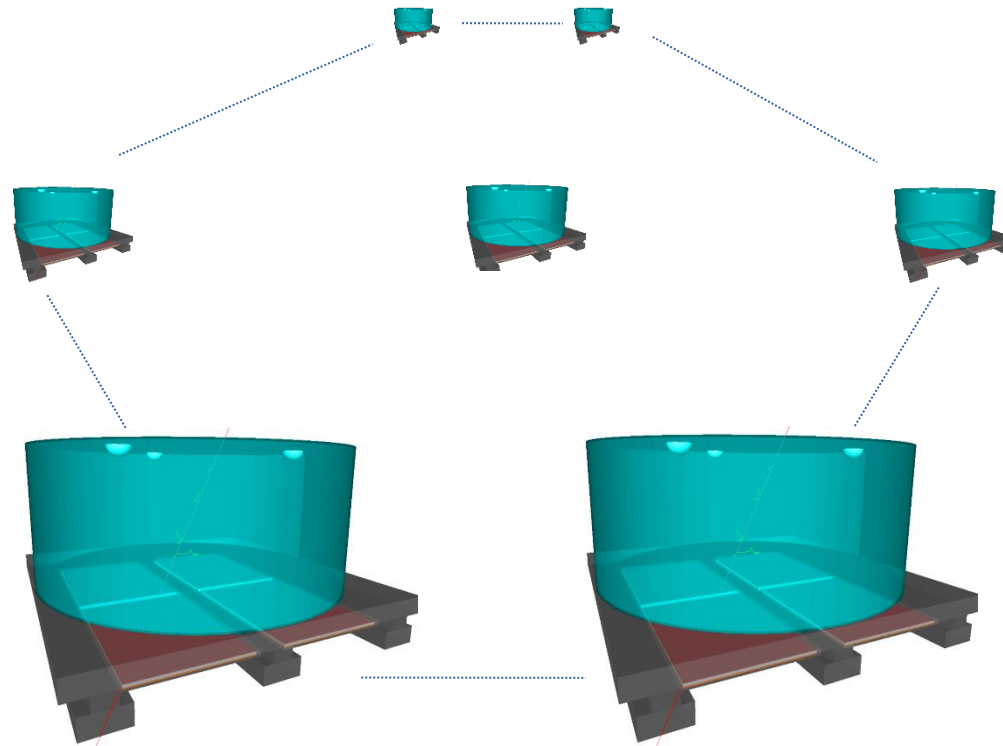

The MARTA Engineering Array

FCT – FAPESP project
(Portugal – Brasil)

Results from a specific call FAPESP-FCT

- RPC R&D
- RPC technology @ Brasil
- Build RPC detectors
- Install EA (hexagon) in Auger

Synergies with AugerPrime

- RPC hodoscopes for testing SSD
- Cross-calibration
- Physics at $E=10^{17}$ eV

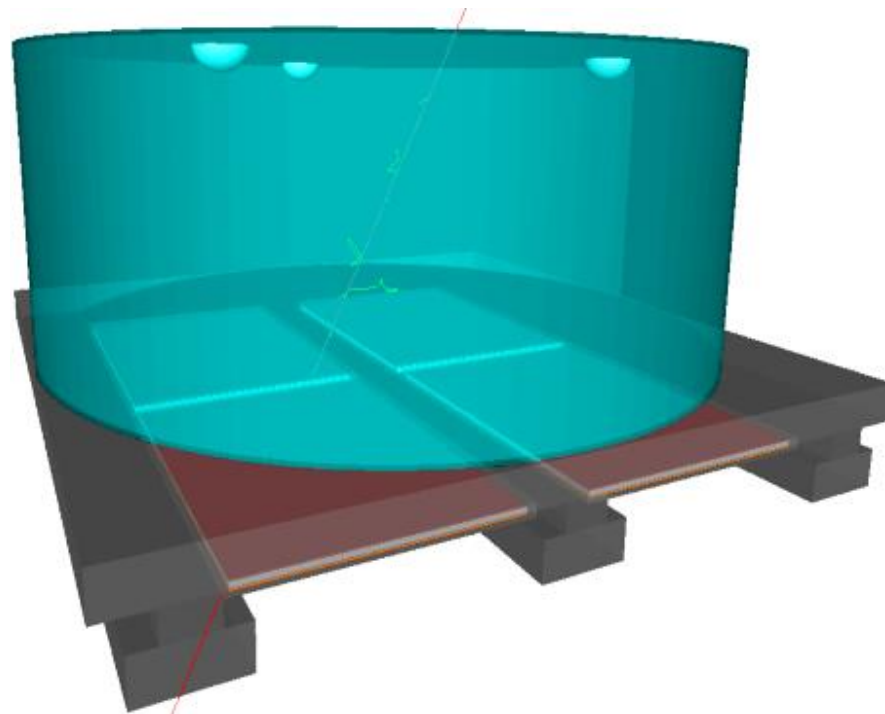
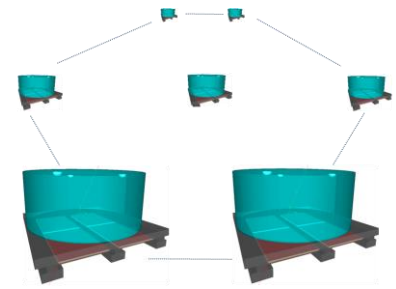

Install a unitary cell (hexagon)
In the infill area, in AMIGA tanks

The support structure

Precast structure built at the observatory
Transported to the field
Installed in a couple of hours
(Emptying/Filling the tank
is more time consuming)

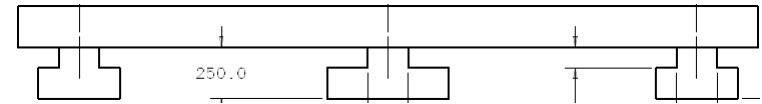
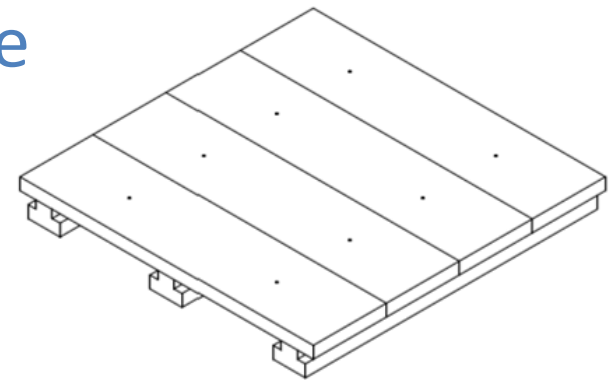

The modules

4 modules of RPC to be installed in each station
Triggered by the WCD

The active medium

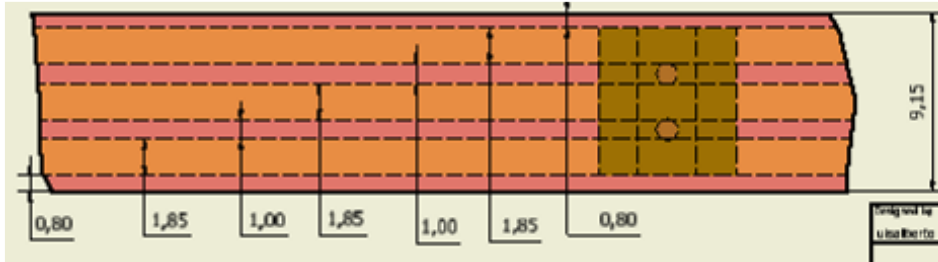

Pads & Housing

(first design)

Pads are defined in PCB boards. Routed with 2mm leaving ground between them

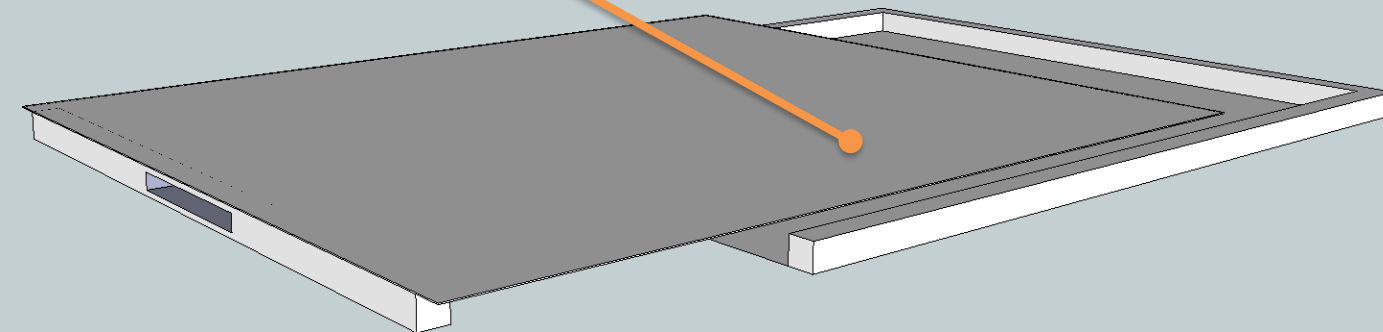
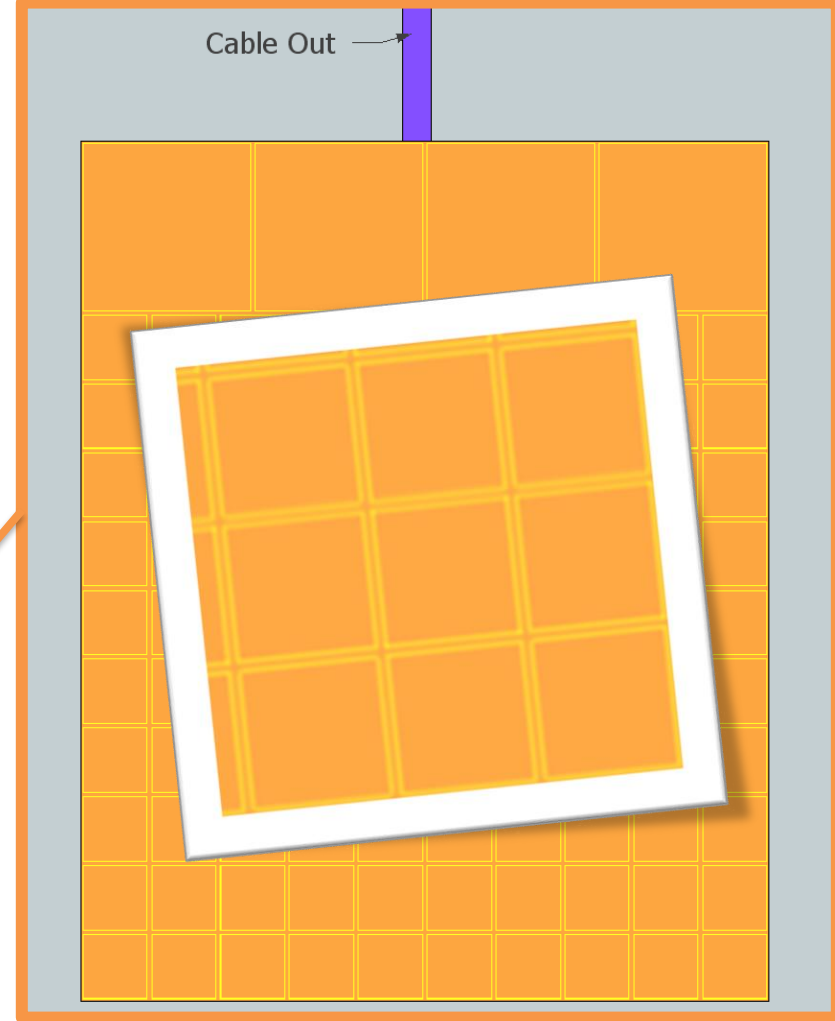
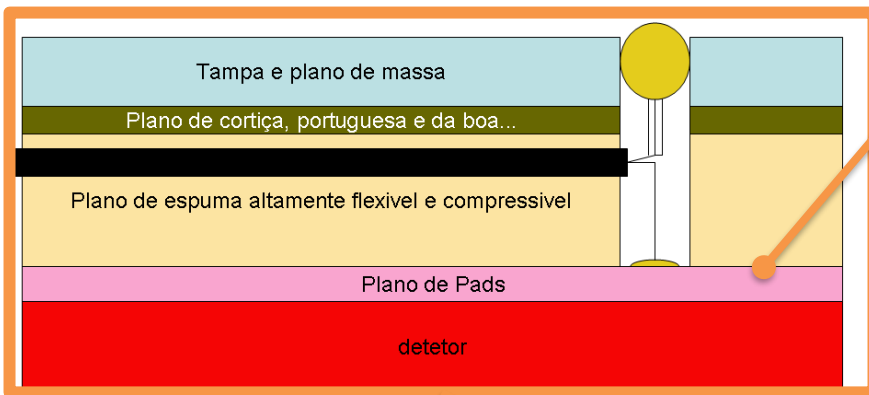

RPC Module

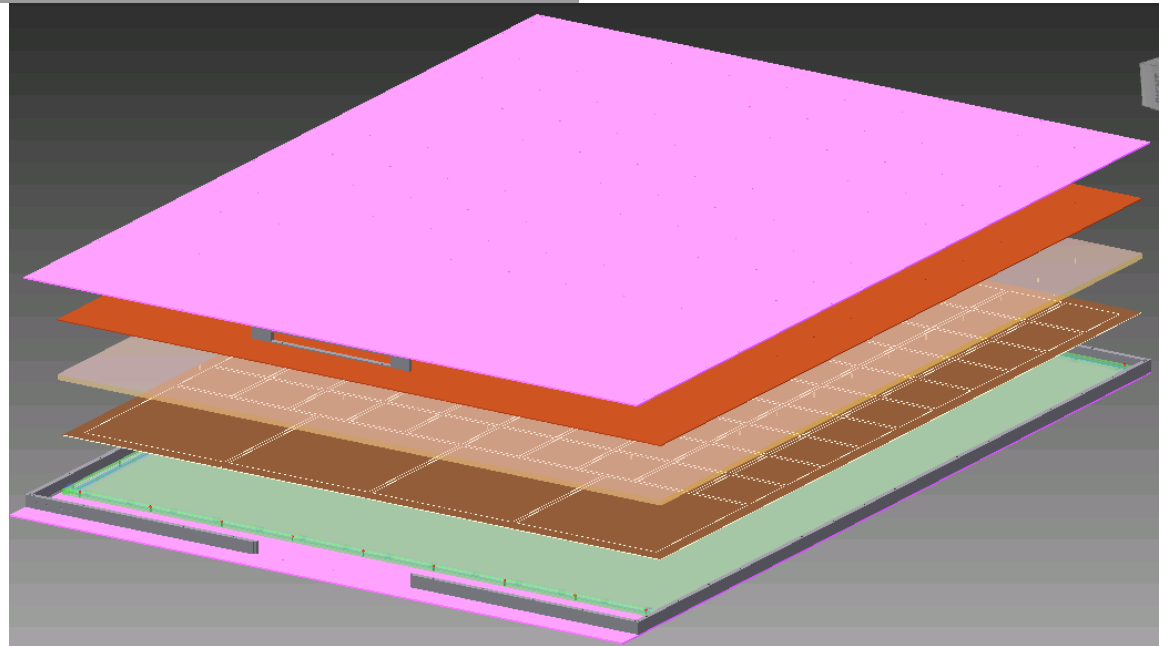
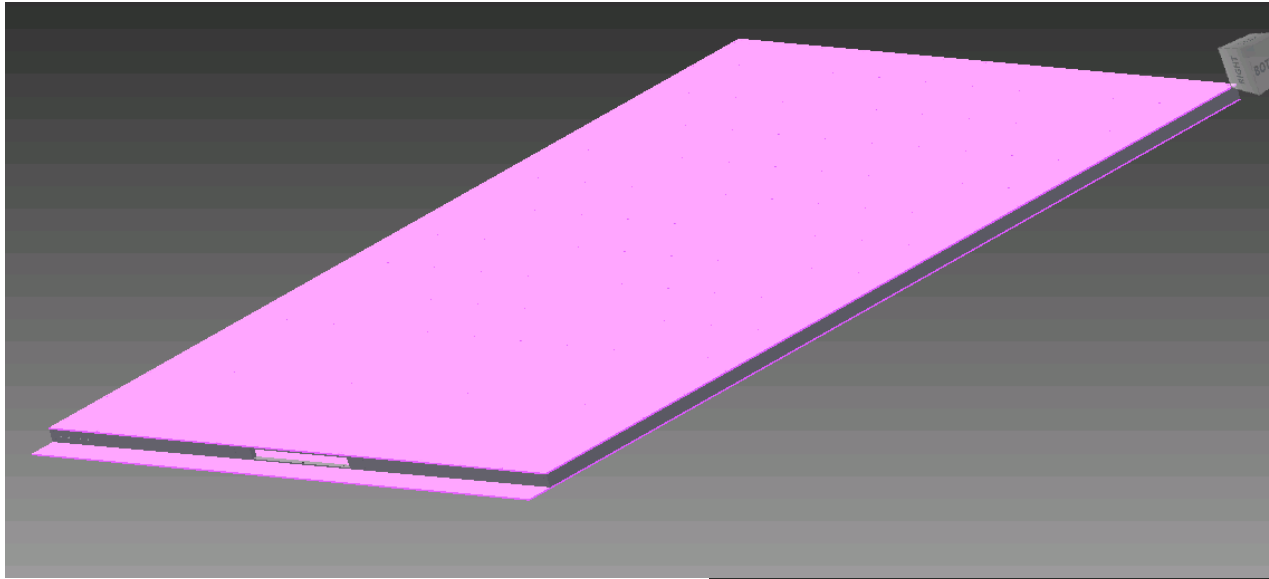

Read-out: Segmentation

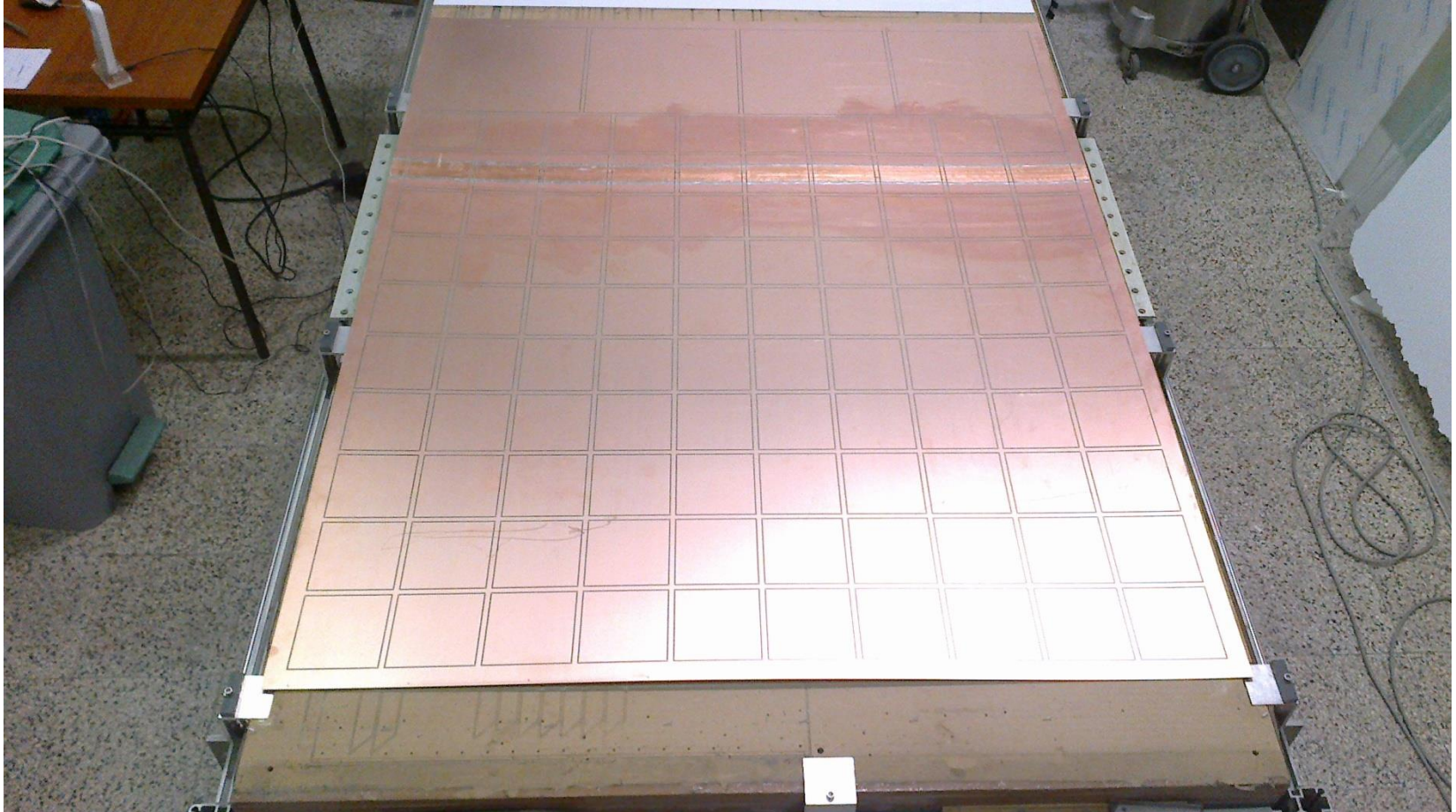

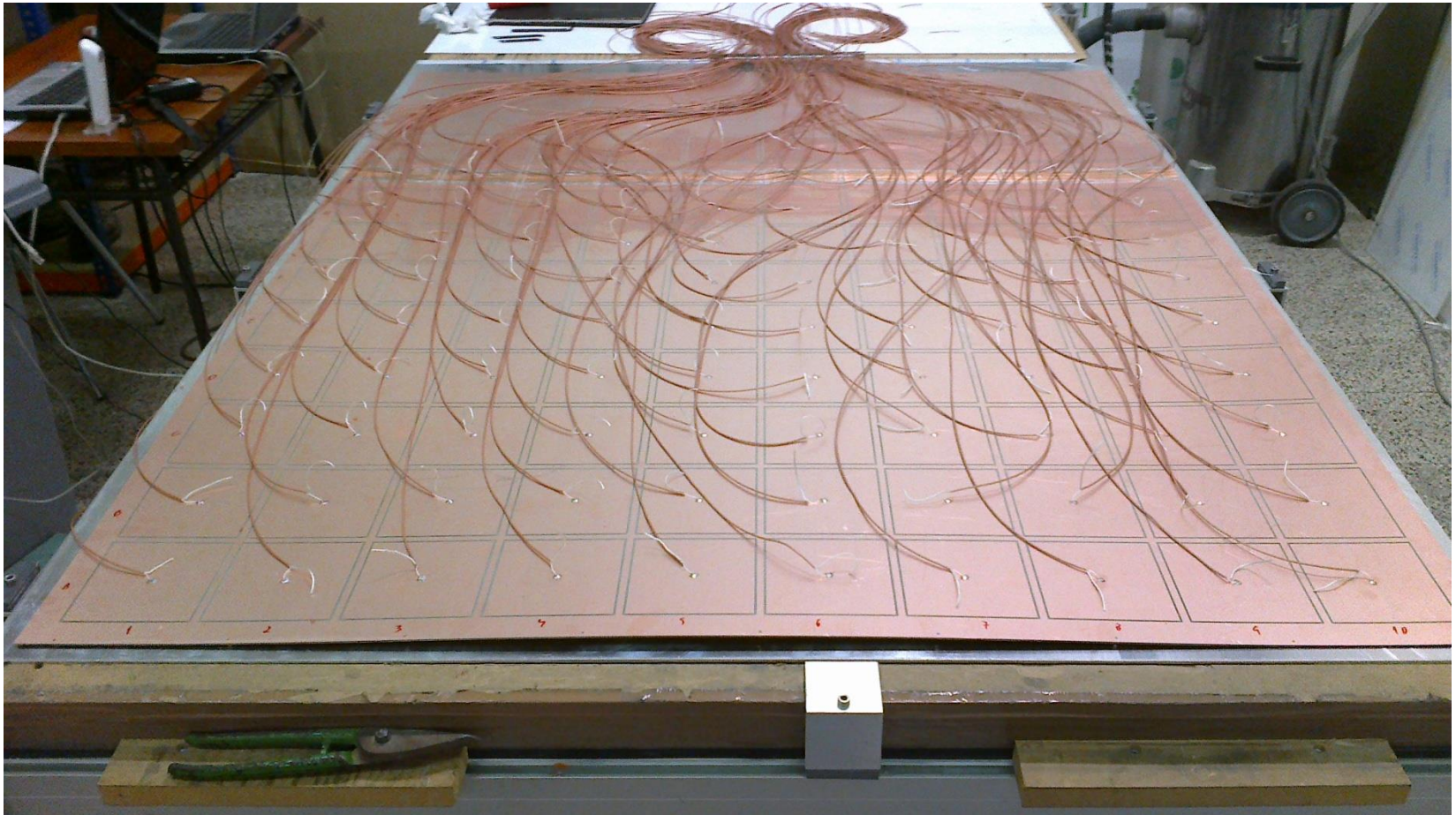

The MARTA module

Each module contains:

- Sensitive volume
- Pickup system
- sensors
- Enclosure
- Annex:
 - DAQ
 - HV
 - PSU
 - Control Board
 - Bubbler

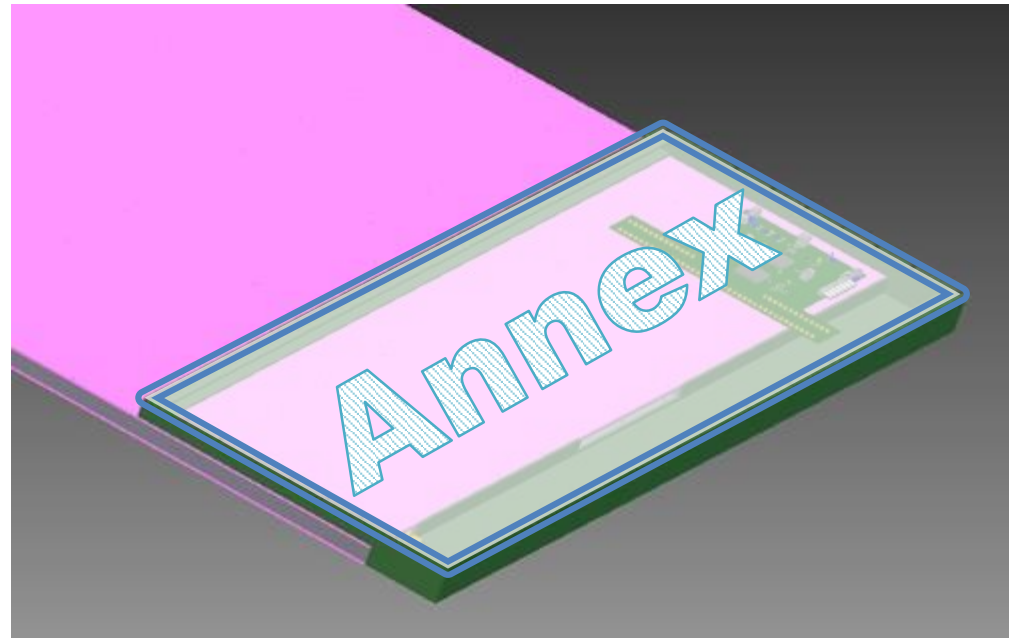

Gas Volume: Coimbra

Gas control: Coimbra

HV: Coimbra

Electronics: Lisboa

Housing: São Carlos

Integration: São Carlos, Rio

The MARTA module

Integration at São Carlos, Brazil



The MARTA module

RPC gaseous volume
(inside aluminum enclosure)

HV
Controllable by SW

Gas
subsystem

64 coax cables from
readout electrodes

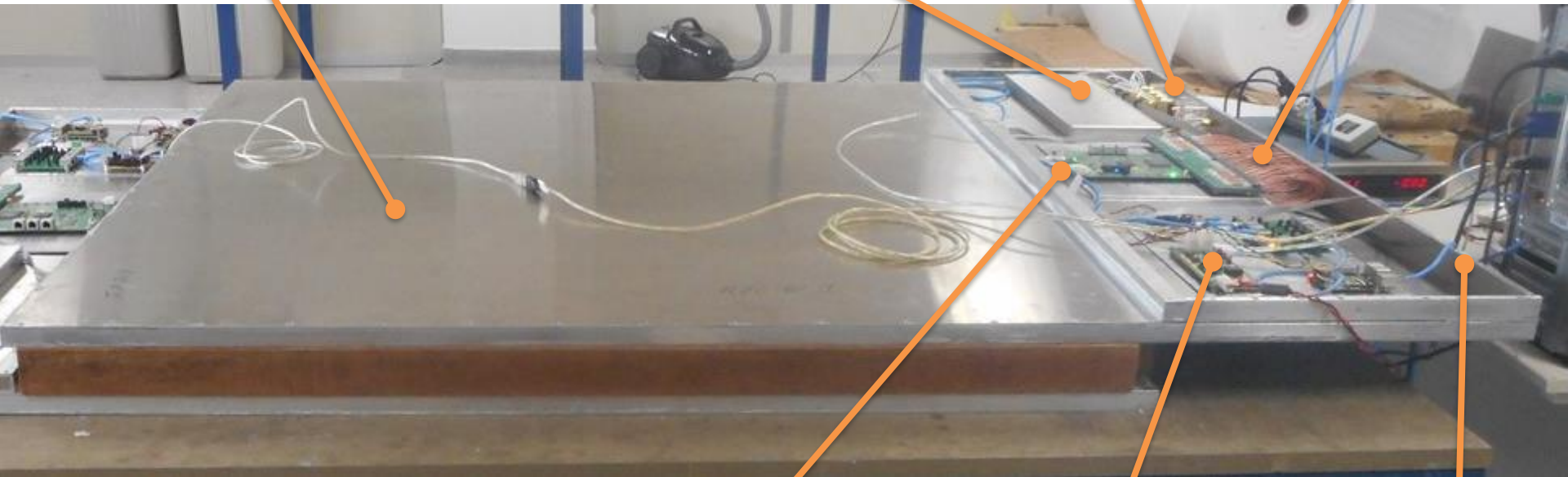

DAQ board

Power and control

DATA
interface

MARTA Readout System

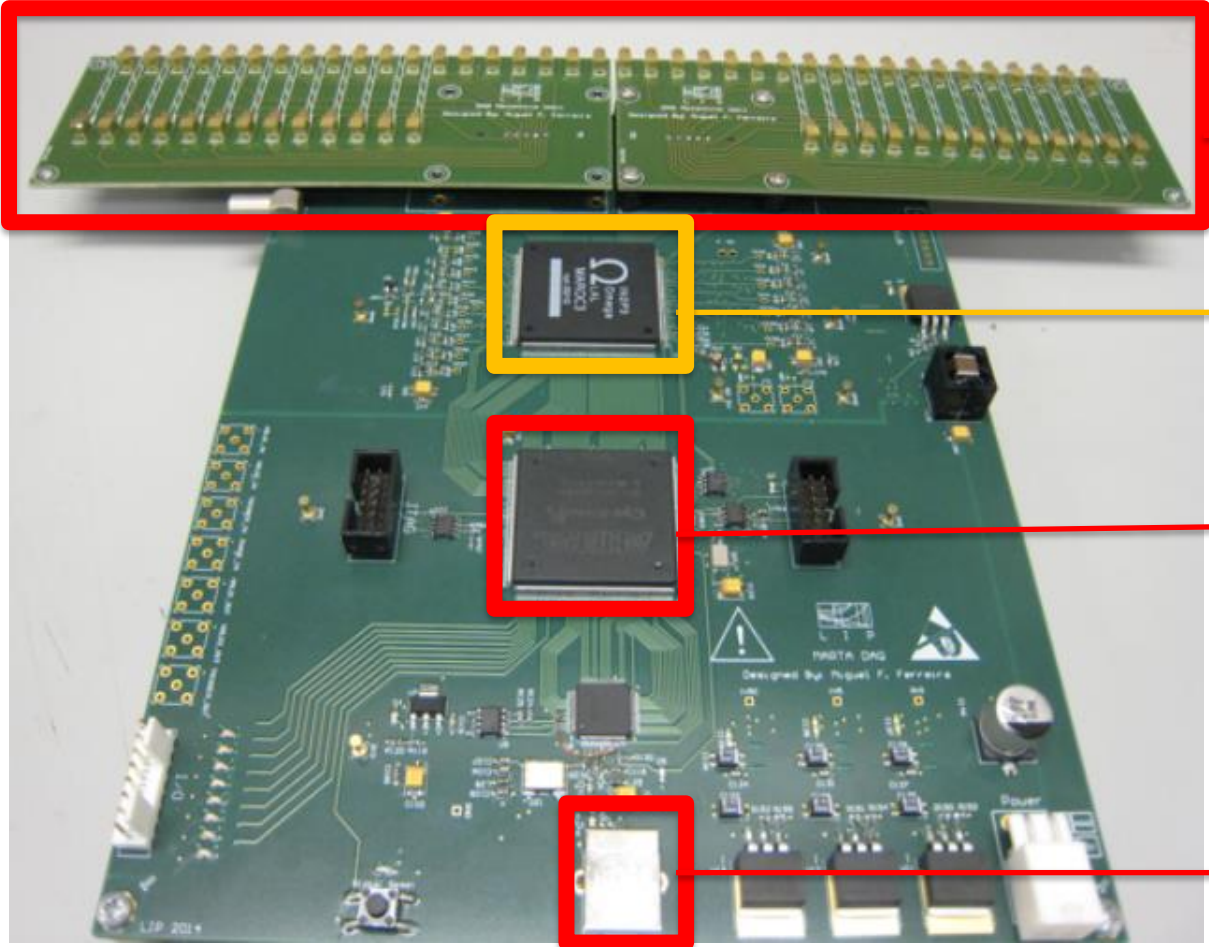

Inputs

MAROC

FPGA

USB port

RPC channel

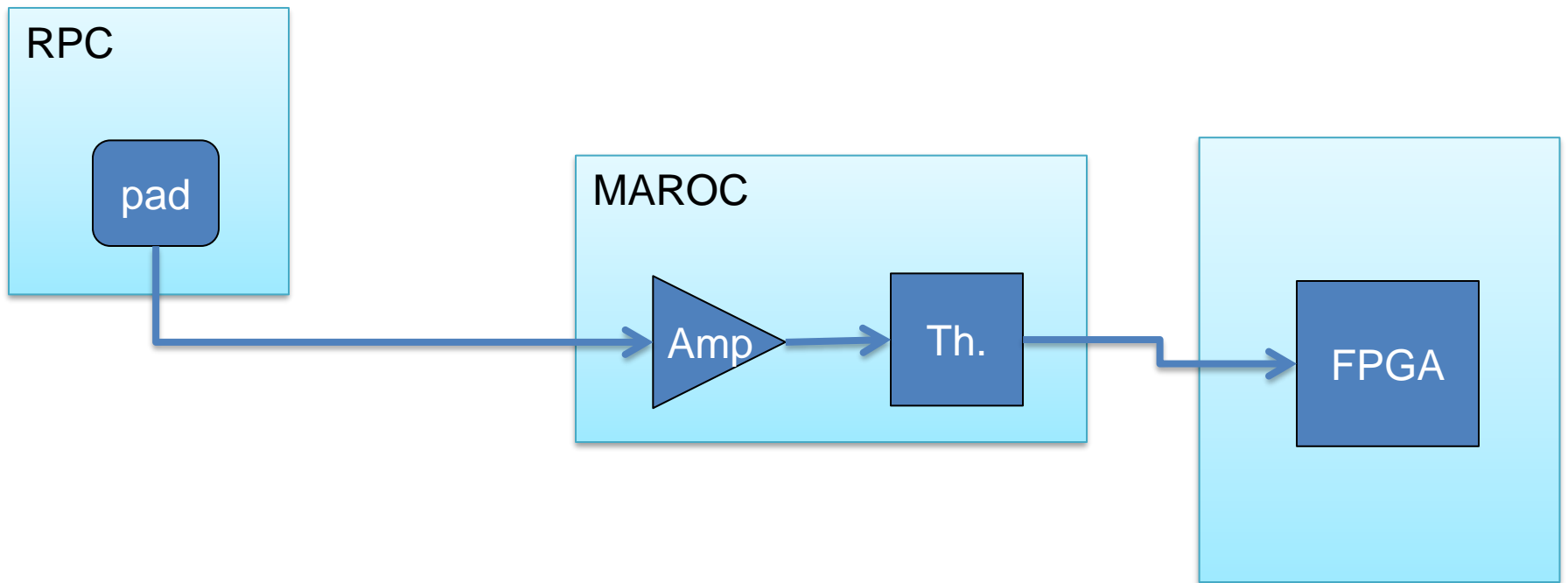

The prototypes

Voldemort

Tierra del Fuego



First field station

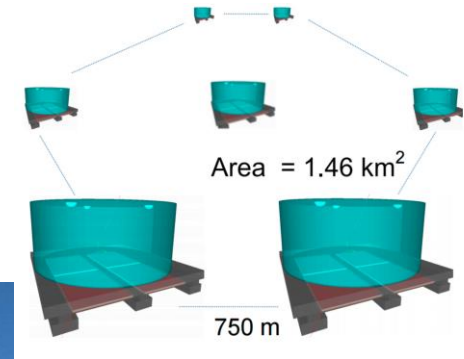

Spin-offs

Hodoscopes to test other detectors



Gianni Navarra setup

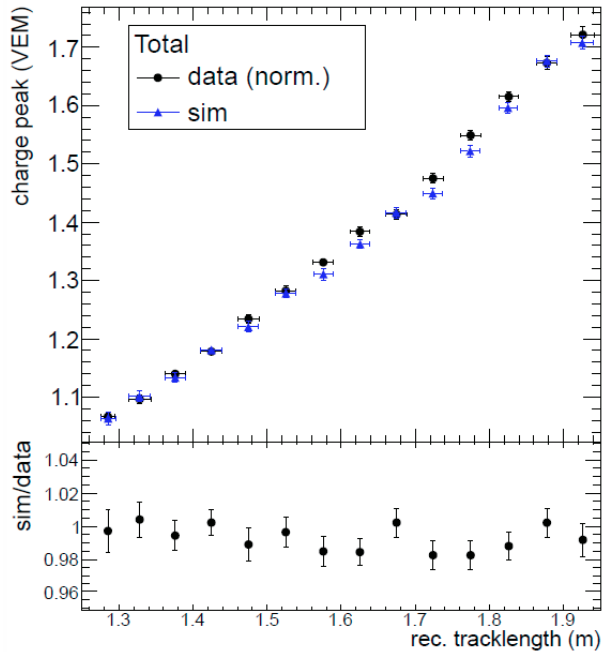

Telescopes
for
muon-graphy





www.lip.pt

pages.lip.pt/auger/

Thank you

Acknowledgements

