

Collision bump amplitudes for the 450 GeV run

Y. Papaphilippou

Thanks to R. Assmann, O. Brüning, D. Duarte Ramos, S. Fartoukh, M. Ferro-Luzzi, M. Giovannozzi, W. Herr, B. Jeanneret, V. Kain, D. Macina, G. Robert-Demolaize, G. Schneider, M. Zerlauth, ABP/LOC team and LHCC working group

December 1st, 2006

Background and outline

■ LTC Actions (August 06)

- Can the experimental spectrometer magnets of IR2 and IR8 operate with their maximum field (corresponding to 7TeV) during the **450 GeV collisions run**?
- Can the VELO detector on IR8 be closed to its minimum aperture?

■ Results presented on LHCCWG (September 06) and LTC (October 06) triggering questions on machine protection

■ Outline

- Motivation from experiments
- IR2/8 nominal injection optics, crossing schemes, spectrometer magnets and internal crossing angles
- Aperture loss for maximum spectrometer strengths at 450 GeV.
- Available aperture for the VELO detector in IR8
- Compensator magnets failure considerations
- Operational and machine protection issues

M. Ferro-Luzzi, et al. PH/LBD

... closing the VELO:

Trigger:

- ❑ Strong constraints on CPU processing time implies 1st processing stage uses 2D tracking (R-Z, no Φ info): essential part of B-physics trigger!
 - ⇒ LHCb wants to commission it as early as possible
- ❑ 2D tracking needs beams to be centered within the circular silicon strip geometry
 - ⇒ close the two halves

Physics:

- ❑ Measure $\sigma_{pp, \text{inelastic}}(900\text{GeV})$: LHCb will attempt an absolute lumi measurement (using novel beam-gas method) with the VELO
- ❑ VELO (acceptance coverage) is essential for this novel method and expected beam-gas rates are rather low
 - ⇒ close the two halves

... operating at (full) $B_{\text{spectrometer}}$:

Calibration/alignment:

- ❑ First check of E(calor) / p(bent track)
- ❑ Could be done with partial field, but
 - Parts of LHCb detector are sensitive to magn. field (such as RICH HPDs)
 - Precise field map done for full field
- ⇒ calibration effort more meaningful at full field.

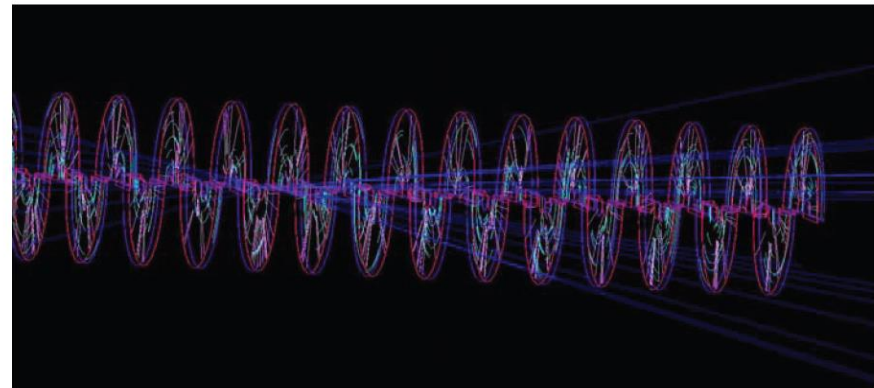

NB:

- ❑ $B \cong 0$ at VELO
- ❑ “open VELO” gives enough tracks to be extrapolated to rest of detector
- ⇒ the 2 jobs could be done independently.

IR2 Injection optics

(O. Brüning et al. LHC Project rep 367 – LHC design report 2004)

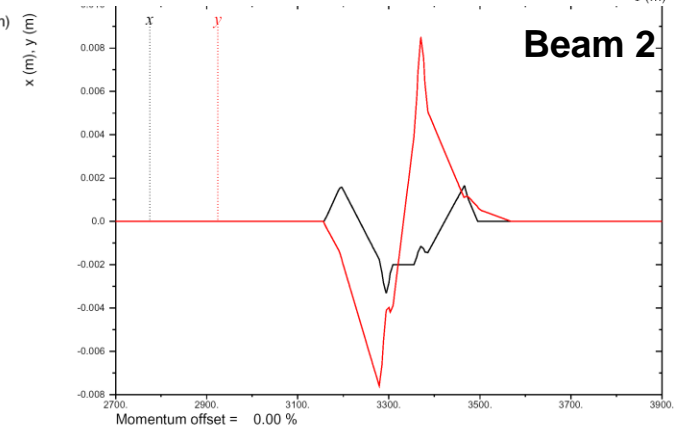
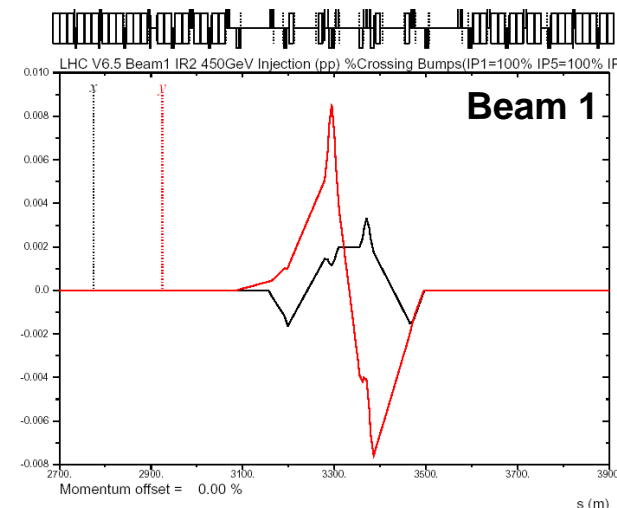
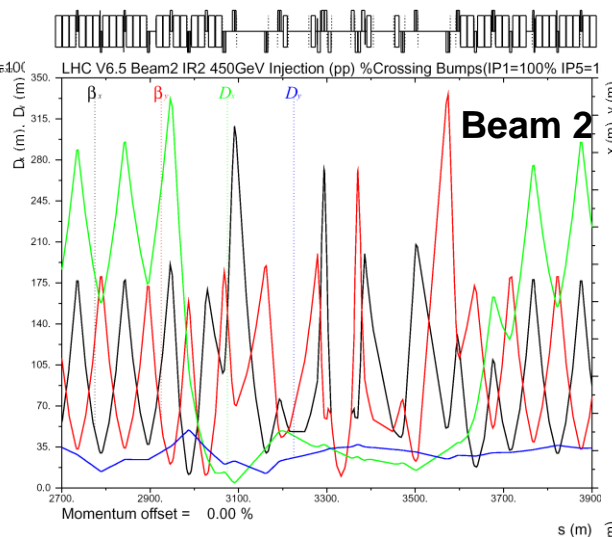
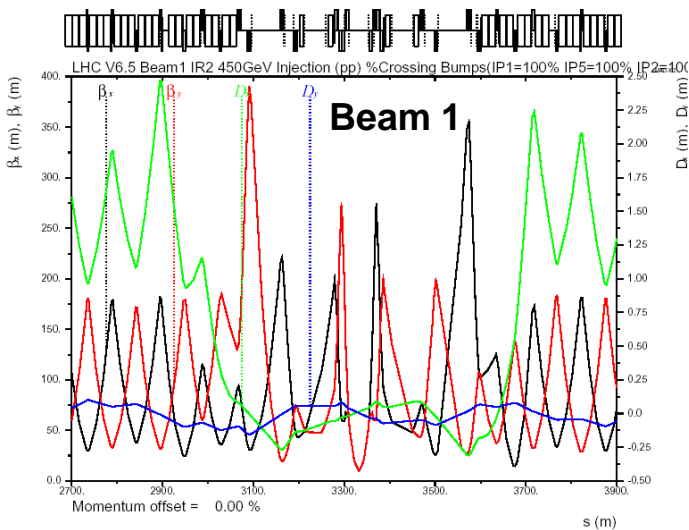

■ $\beta^*=10\text{m}$, vertical crossing angle of $\pm 240\mu\text{rad}$ and horizontal parallel separation of $\pm 2\text{mm}$

- External angle of $\pm 170\mu\text{rad}$ for reducing the long range beam-beam effect
- Internal angle of $\pm 70\mu\text{rad}$ for compensating spectrometer orbit distortion

□ Horizontal separation positive for Beam 1 and negative for Beam 2, due to the ring geometry

□ Angle sign can be chosen arbitrarily (following spectrometer polarity)

ALICE dipole magnet and its compensators

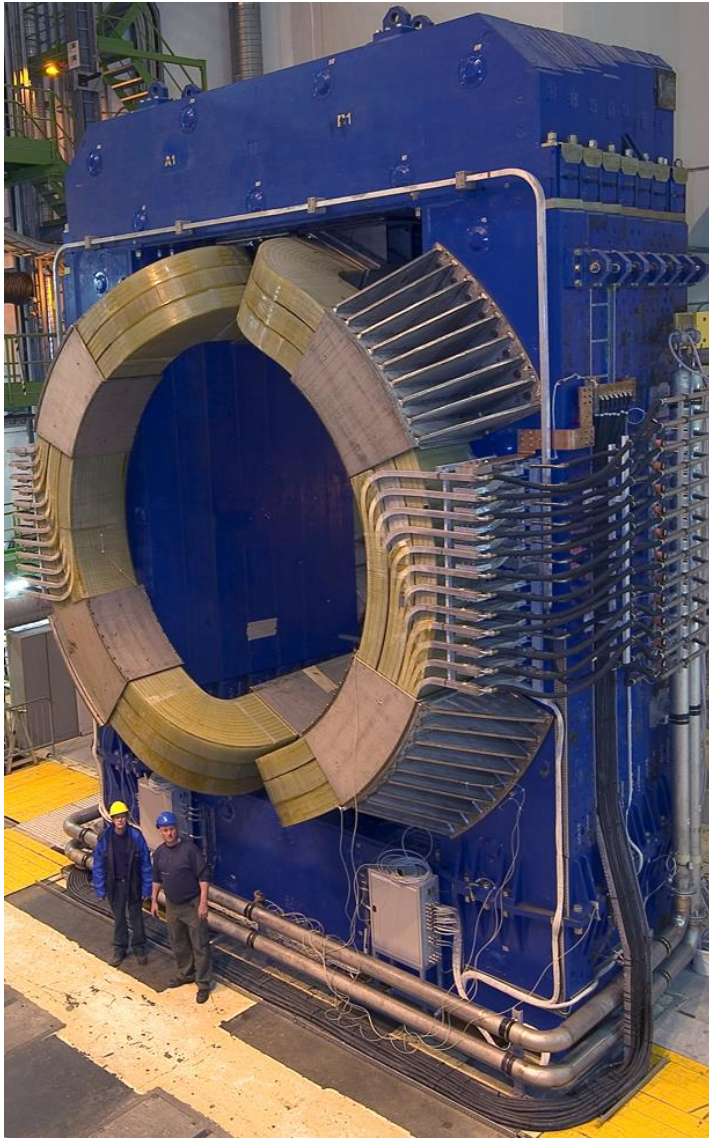

- 3m-long spectrometer dipole (**MBAW**) @ 10m to the right of the IP
- Vertical deflection with nominal integrated field of 3Tm (deflection of $130\mu\text{rad}$ @ 7TeV)
- The resulting orbit deflection is compensated by three dipole magnets
 - Two 1.5m-long magnets of type **MBXWT** @ 20m left and right of the IP
 - One 2.6m-long magnet of type **MBWMD** @ 10m to the left of the IP
- Two Beam Position Monitors (**BPMWS**) are located upstream and downstream of the two MBXWT to monitor the internal bump closure

Injection optics around IR2

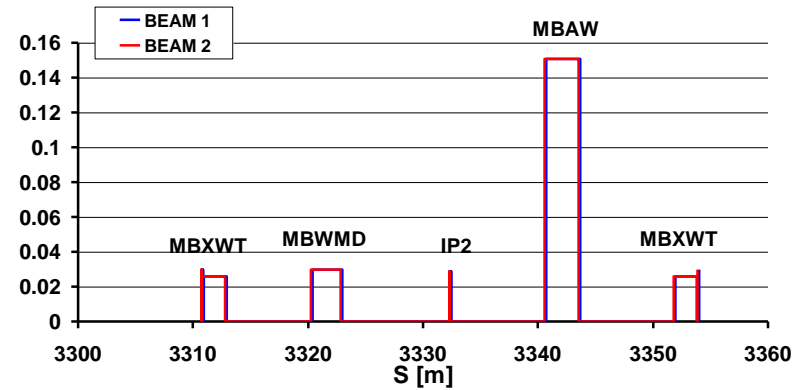
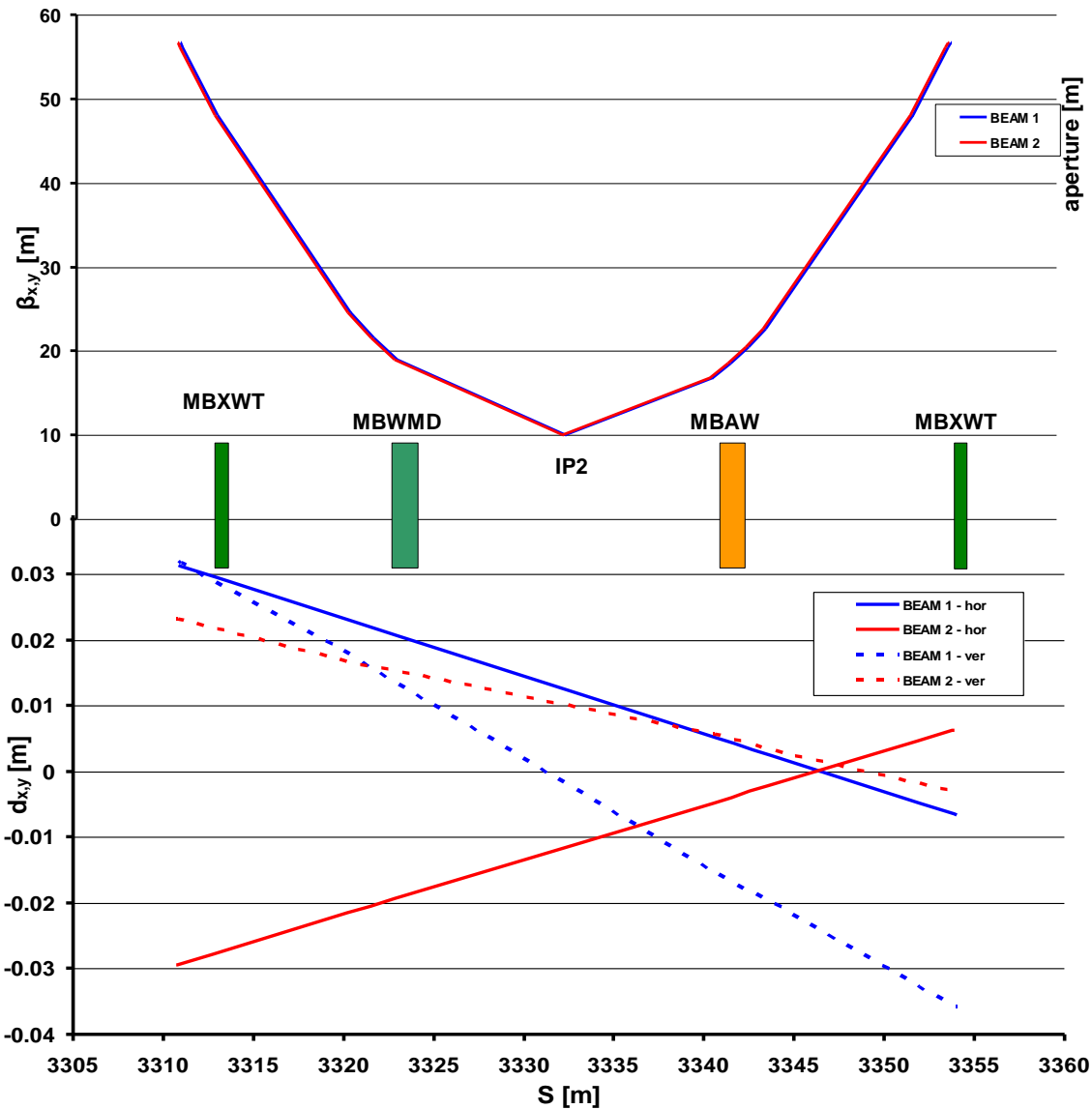

Equipment	Aperture [mm]	β [m]
BPMSW.1L2	30	57
MBXWT.1L2	26	56 - 48
MBWMD.1L2	30	24 - 19
IP2	29	10
MPAW.1R2	151	17 - 23
MBXWT.1R2	26	48 - 56
BPMSW.1R2	30	57

■ Beam size varies between 0.8 and 0.3mm

■ The dispersion is smaller than a few cm

Internal crossing bump of IR2

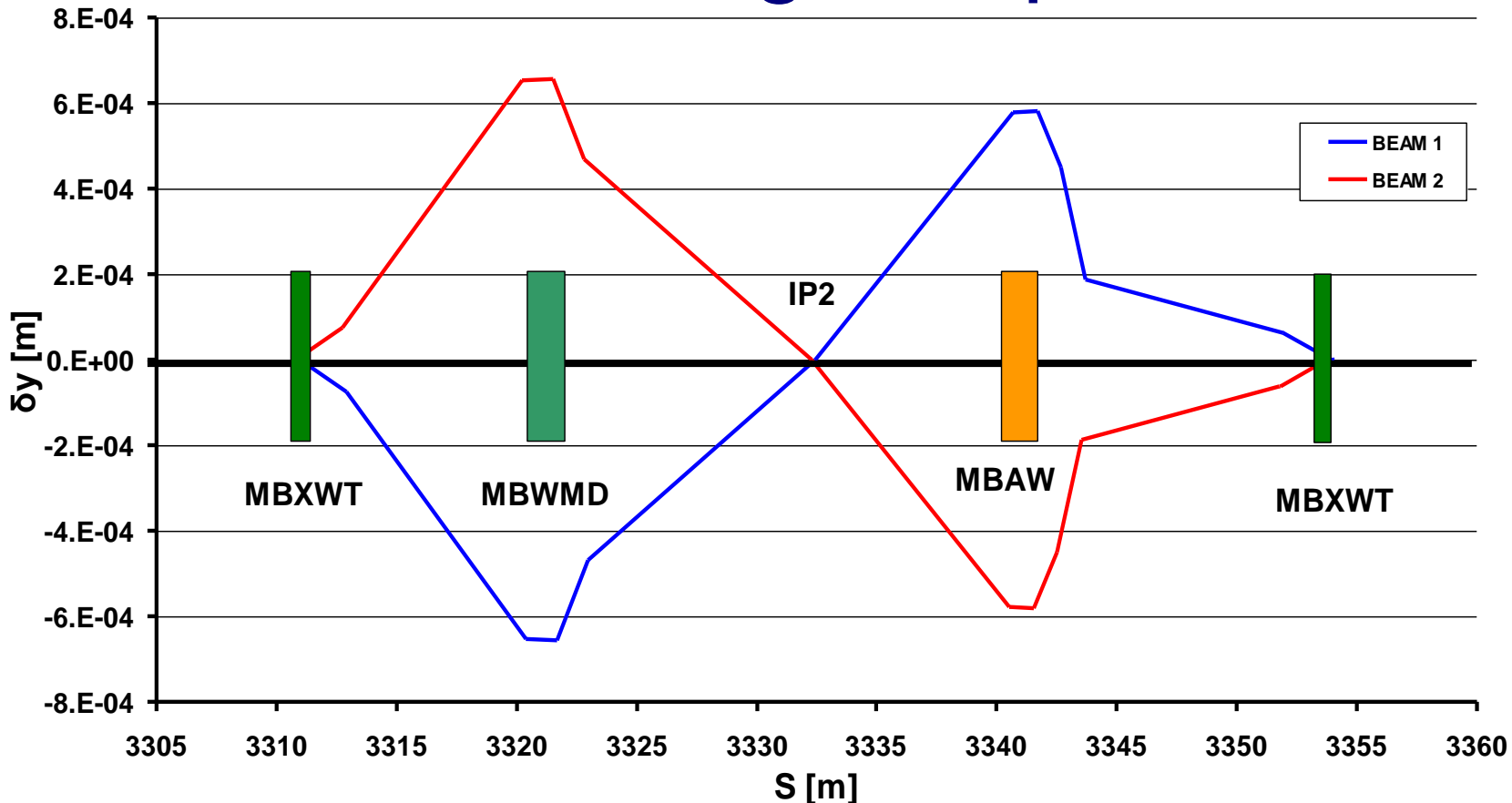

- Internal crossing angle of $\pm 70 \mu\text{rad}$ in the vertical plane (maximum deflection of ± 0.7 mm at **MBWMD**)
- External crossing angle follows spectrometer dipole polarity

Nominal injection aperture in IR2

Equipment	n_1 [σ]	n_1 [mm]	n_1 [%]
BPMSW.1L2	20	14	47
MBXWT.1L2	17	11	42
MBWMD.1L2	33	14	47
IP2	53	15	52
MBAW.1R2	221	93	58
MBXWT.1R2	17	11	42
BPMSW.1R2	20	14	47

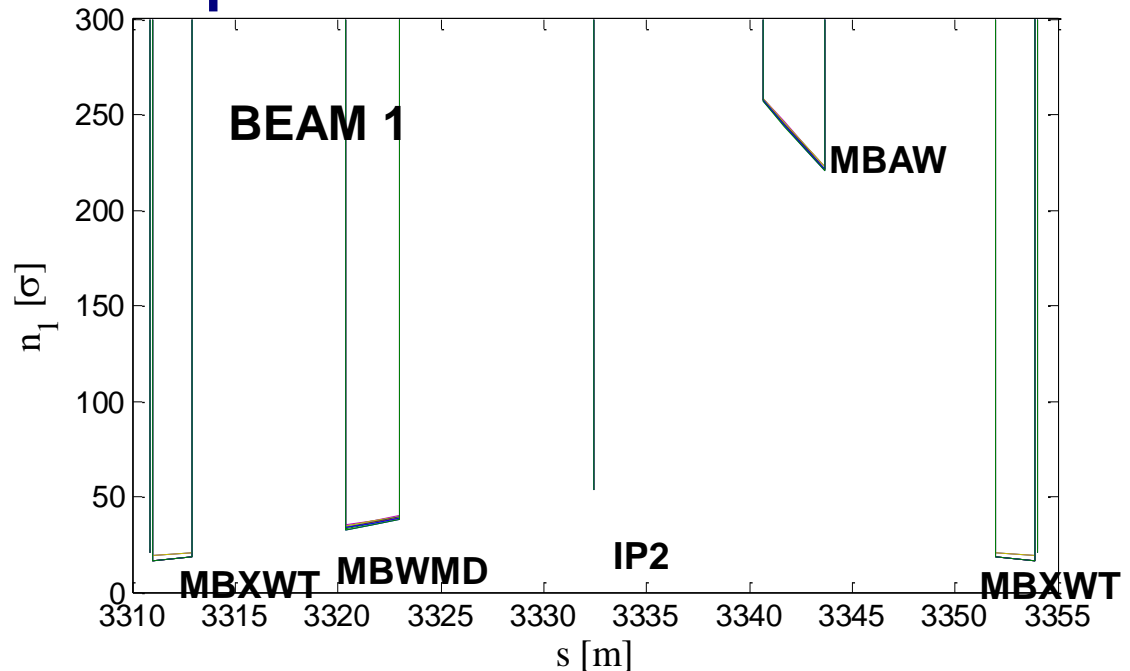

- Aperture is computed taking into account nominal tolerances (see [LHC Design report 2004](#))
 - β -beating of 20%, spurious dispersion of 0.27, momentum offset of 0.15%, peak closed orbit of 4mm and mechanical tolerances for each magnet
- Different scenarios are considered
 - \pm or no external crossing angle, \pm internal crossing angle, with/without separation bump
 - Aperture varies for less than 3σ among the different cases and for both beams
- Around 50% of the available aperture is lost in all compensators and 40% in the spectrometer (but a lot of margin in that area)

Internal crossing bump of IR2 with collision strength for the spectrometer dipole

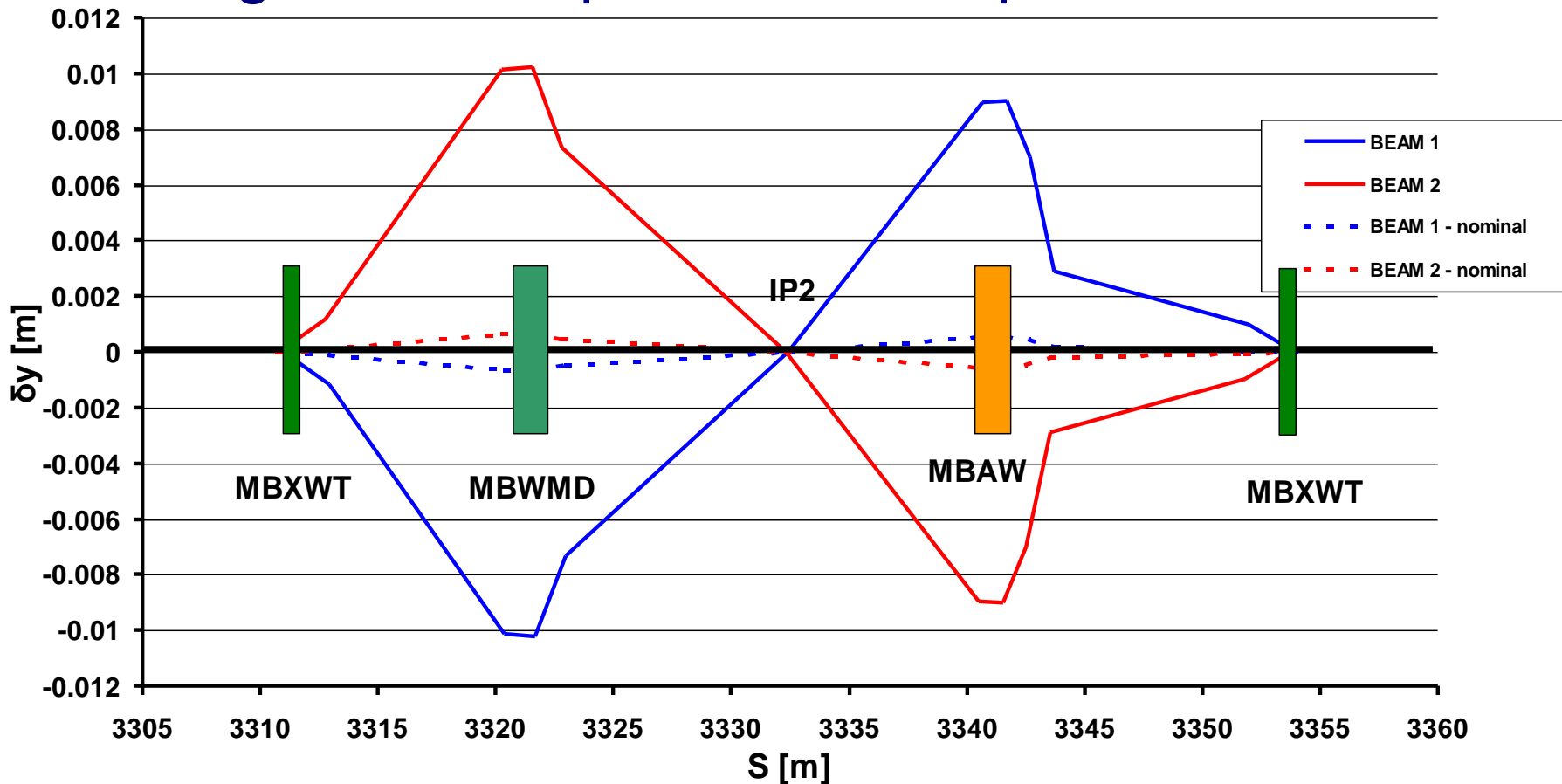

- Internal crossing angle of $\pm 1.1 \text{ mrad}$ in the vertical plane
- Maximum deflection of $\pm 11 \text{ mm}$ at **MBWMD**, corresponding to 25σ , as compared to $\pm 0.65 \text{ mm}$ (1.6σ) of the nominal injection bump

Aperture in IR2 with full spectrometer dipole strength

Not important impact in any element apart **MBWMD**

- Available aperture of 9mm (with respect to 14mm), corresponding to 13σ of aperture loss
- Remaining aperture is 30% of the available

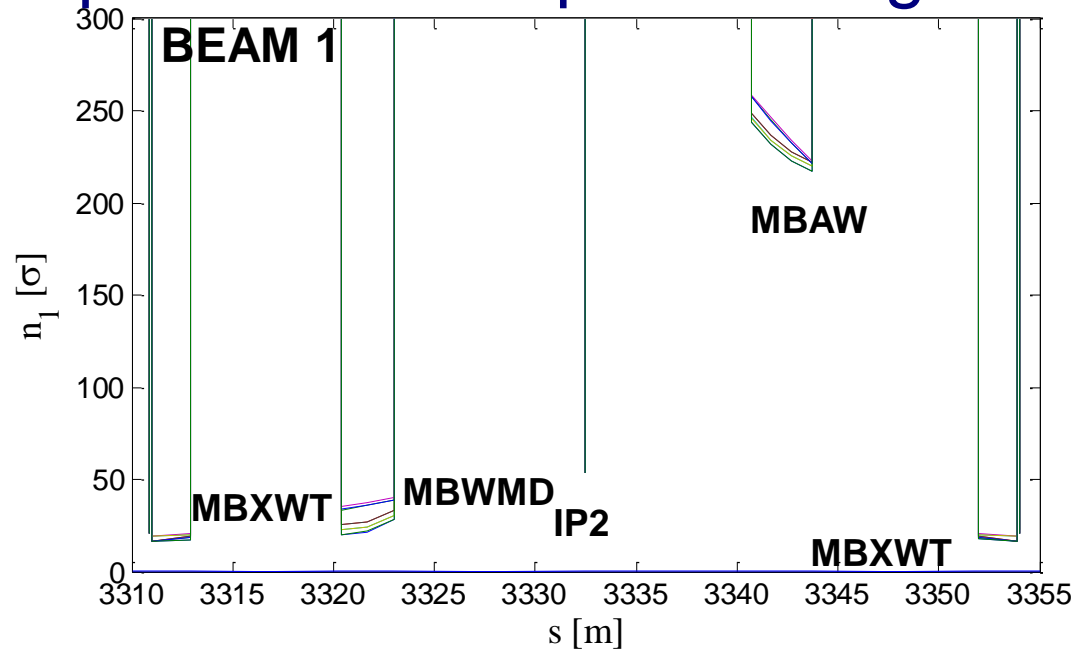

Equipment	n_1 nominal [σ]	n_1 full [σ]	n_1 nominal [mm]	n_1 full [mm]	n_1 nominal [%]	n_1 full [%]
BPMSW.1L2	20	20	14	14	47	47
MBXWT.1L2	17	17	11	11	42	42
MBWMD.1L2	33	20	14	9	47	30
IP2	53	53	15	15	52	52
MBAW.1R2	221	217	93	88	62	58
MBXWT.1R2	17	17	11	11	42	42
BPMSW.1R2	20	20	14	14	47	47

IR8 Injection optics

(O. Brüning et al. LHC Project rep 367 – LHC design report 2004)

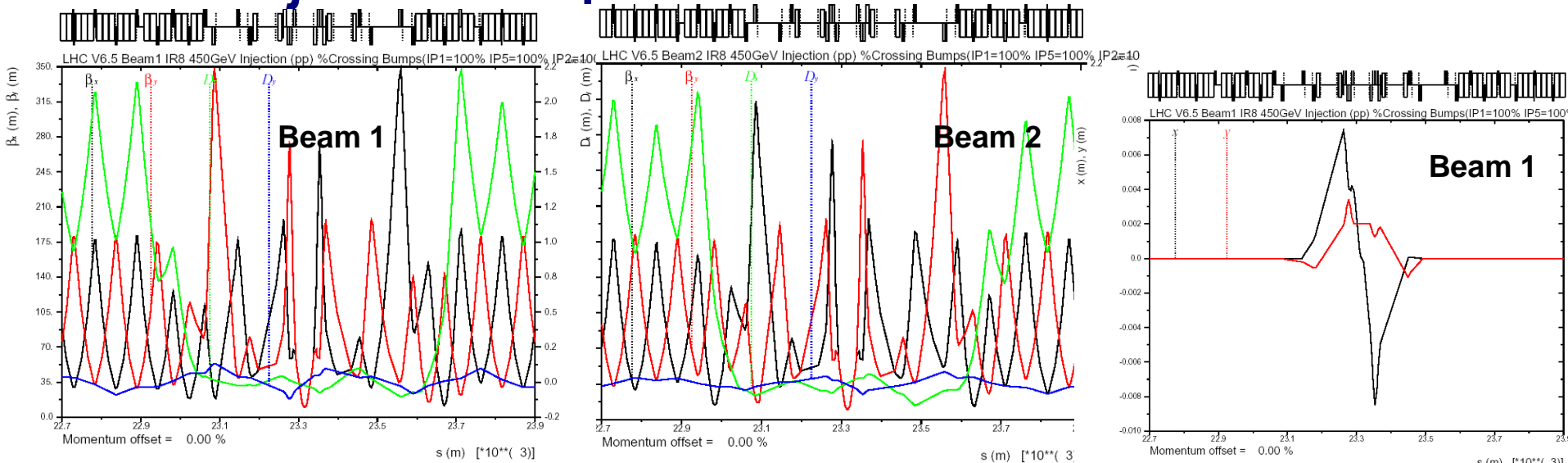

■ $\beta^*=10\text{m}$, horizontal crossing angle of $-/+35$ or $-/+300\mu\text{rad}$ depending on spectrometer polarity and vertical parallel separation of $\pm 2\text{mm}$

- External angle of $-/+170$ (+ polarity) or $-/+165\mu\text{rad}$ (+ polarity)
- Internal angle of $\pm 135\mu\text{rad}$ for compensating spectrometer orbit distortion
- Horizontal crossing angle always negative for Beam 1 and positive for Beam 2
- Vertical separation sign can be chosen arbitrarily

LHCb dipole magnet

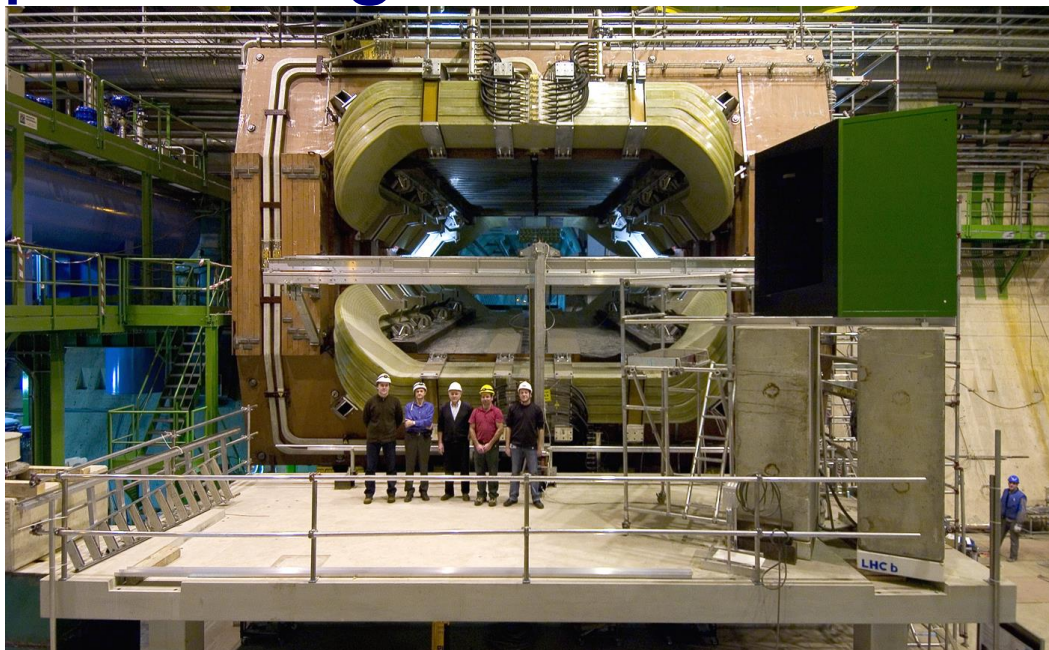

- 1.9m-long spectrometer dipole (**MBLW**) @ 4.9m to the right of the IP
- Horizontal deflection with nominal integrated field of 4.2Tm (deflection of $180\mu\text{rad}$ @ 7TeV)
- The resulting orbit deflection is compensated by three dipole magnets
 - Two 0.8m-long magnets of type **MBXWS** @ 20m left and right of the IP
 - One 3.4m-long magnet of type **MBXWH** @ 5m to the left of the IP
- Two Beam Position Monitors (**BPMWS**) are located upstream and downstream of the two MBXWS to monitor the internal bump closure

Injection optics around the IR8

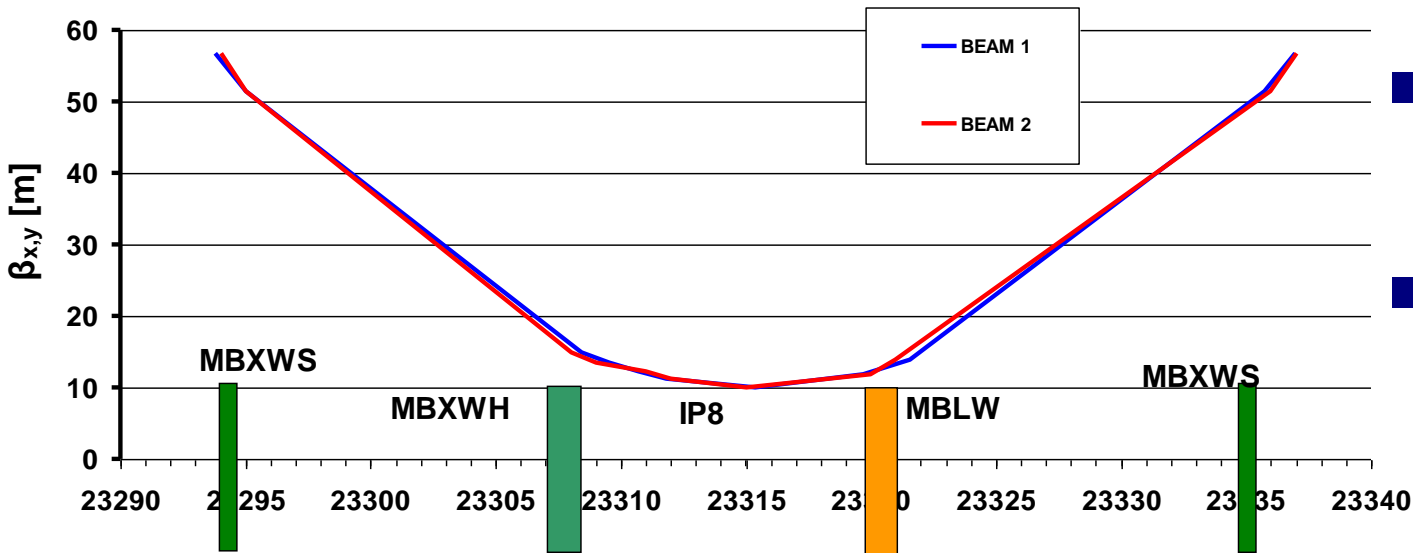

- Beam size varies between 0.7 and 0.3mm
- The dispersion is smaller than a few cm, as in IR2

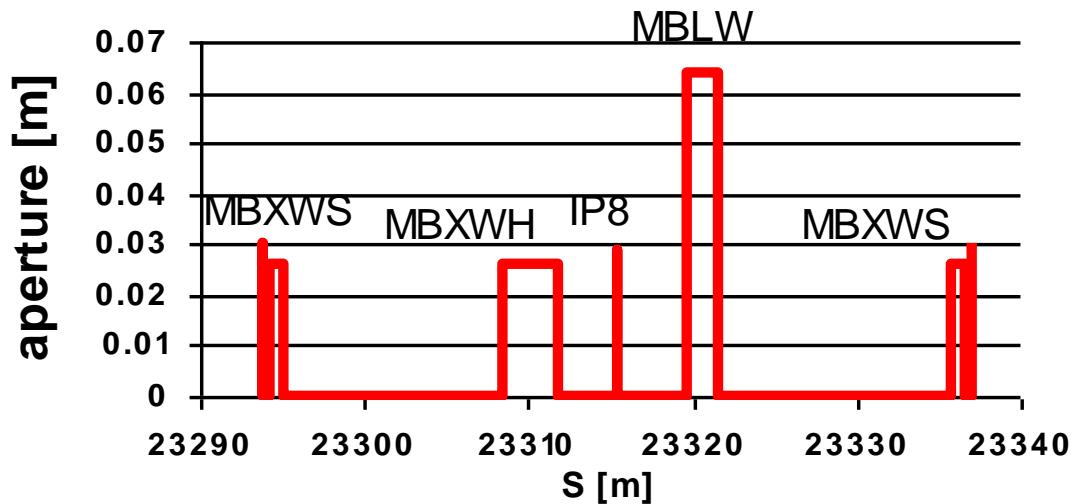

Equipment	Aperture [mm]	β [m]
BPMSW.1L8	30	57
MBXWS.1L8	26	55 - 52
MBXWH.1L8	26	15 - 12
IP8	30	10
MBLW.1R8	64	12 - 14
MBXWS.1R8	26	52 - 55
BPMSW.1R8	30	57

Internal crossing bump of IR8

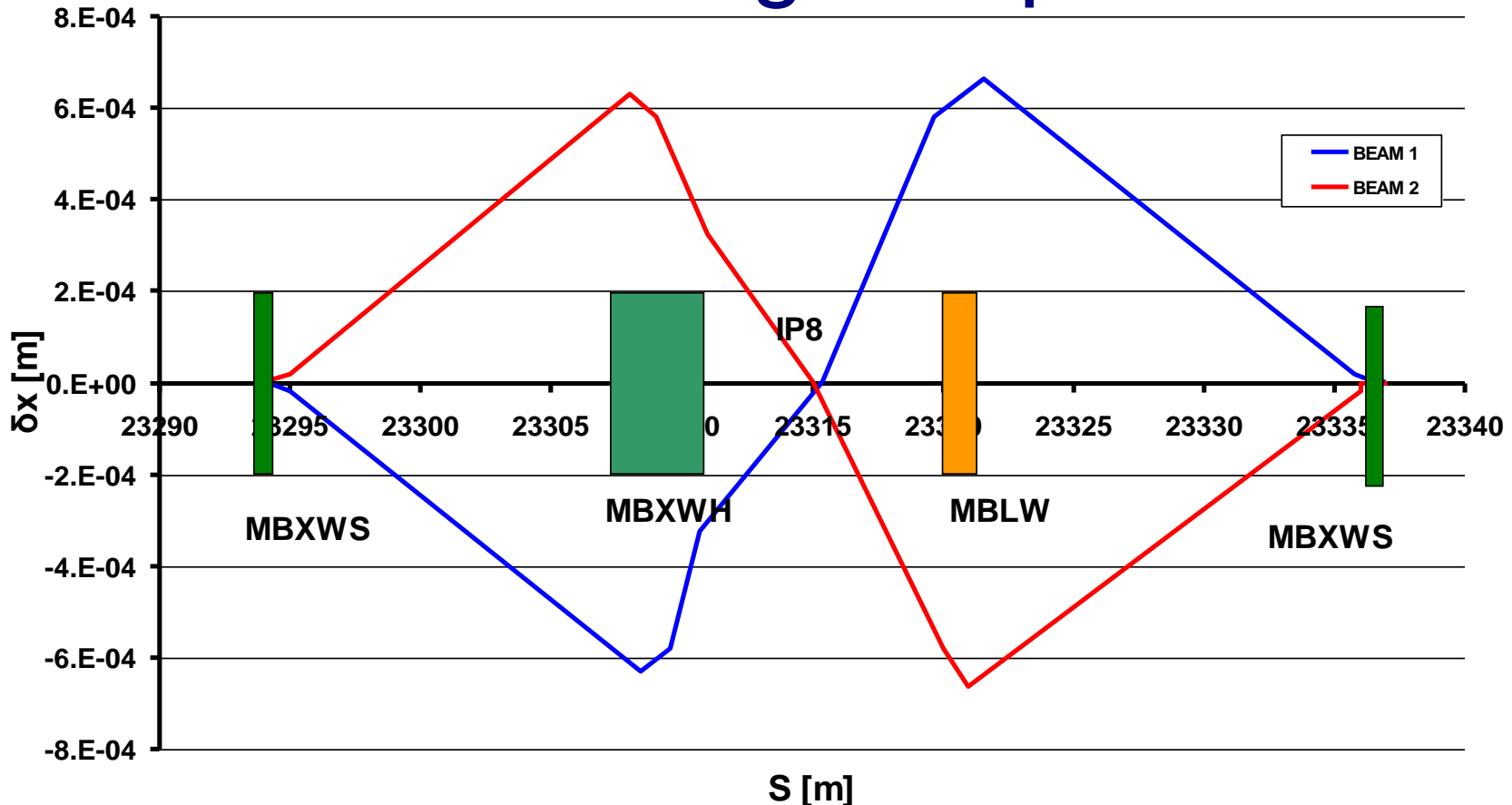

- Internal crossing angle of $\pm 135 \mu\text{rad}$ in the horizontal plane (maximum deflection of $\pm 0.6 \text{ mm}$ at MBXWH)

- External crossing angle does not follow spectrometer dipole polarity

Nominal injection aperture in IR8

Equipment	n_1 [σ]	n_1 [mm]	n_1 [%]
BPMSW.1L8	20	14	45
MBXWS.1L8	16	10	40
MBXWH.1L8	34	12	45
IP8	56	16	52
MBLW.1R8	111	37	58
MBXWS.1R8	16	10	40
BPMSW.1R8	20	14	45

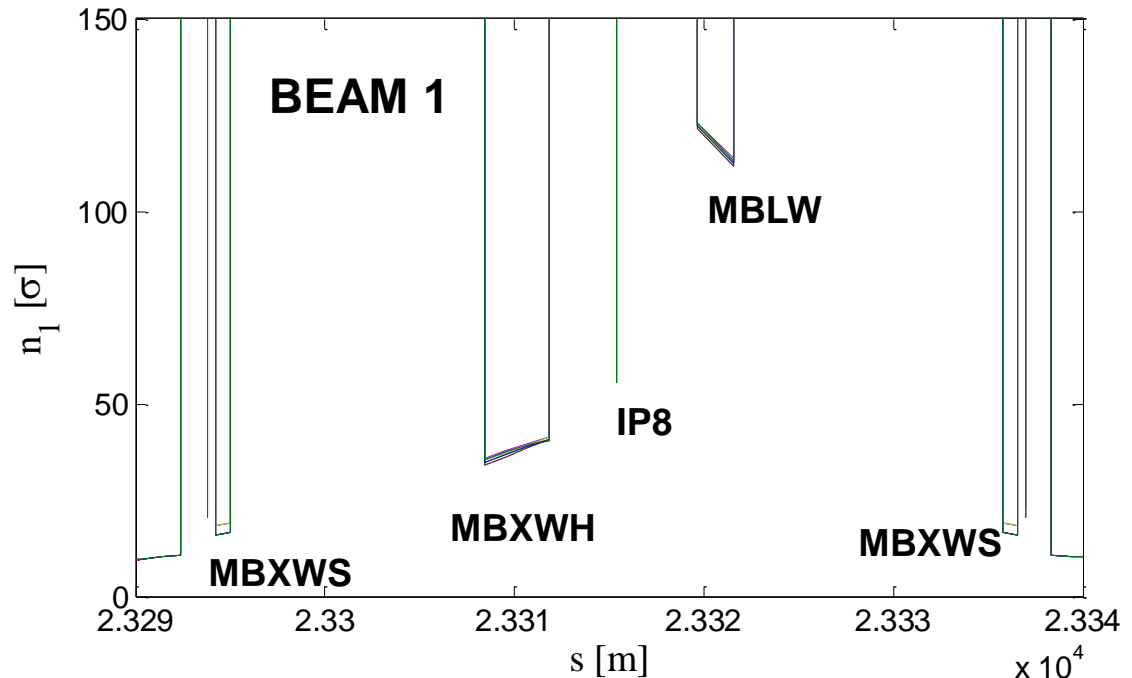

- Aperture is computed taking into account the nominal tolerances and the scenarios studied for IR2
- Differences with respect to IR2 on the 2nd compensator (smaller β) and spectrometer (smaller β and aperture)
- Aperture varies for less than 3σ between the scheme with only internal and complete crossing scheme and for both beams and separation polarities
- Around 50-60% of the available aperture is lost for all compensators and 40% for the spectrometer

Internal crossing bump of IR8 with collision strength for the spectrometer dipole

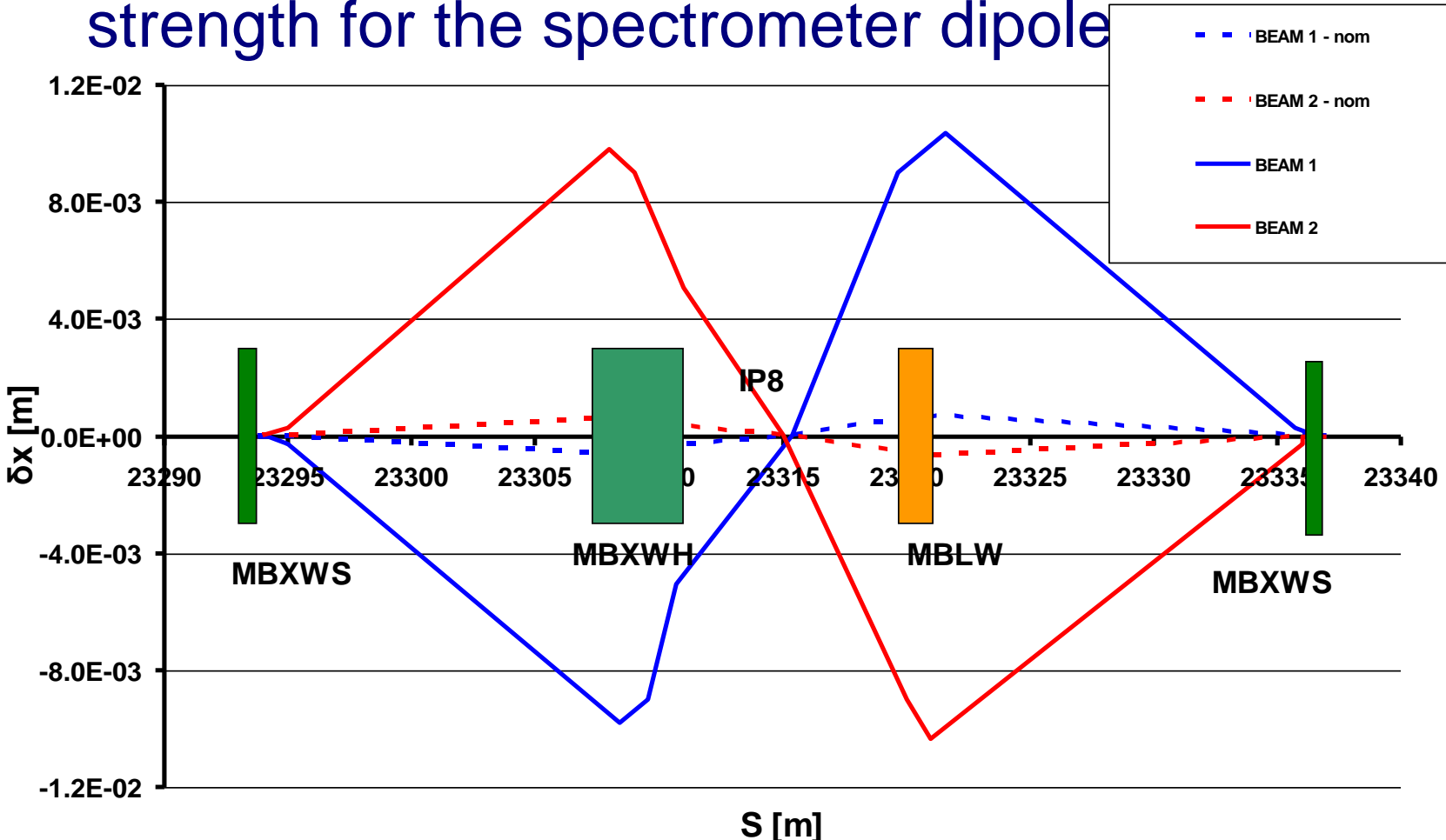

- Internal crossing angle of $\pm 2.1 \text{ mrad}$ in the horizontal plane
- Deflection of **10mm** at MBXWH, corresponding to **29 σ** , as compared to **0.6mm (2 σ)** of the nominal bump

Aperture in IR8 with full spectrometer dipole strength

Not important impact in any element apart **MBXWH**

- Available aperture of 6mm (with respect to 12mm), corresponding to 15σ of aperture loss
- Remaining aperture corresponds 24% of the available

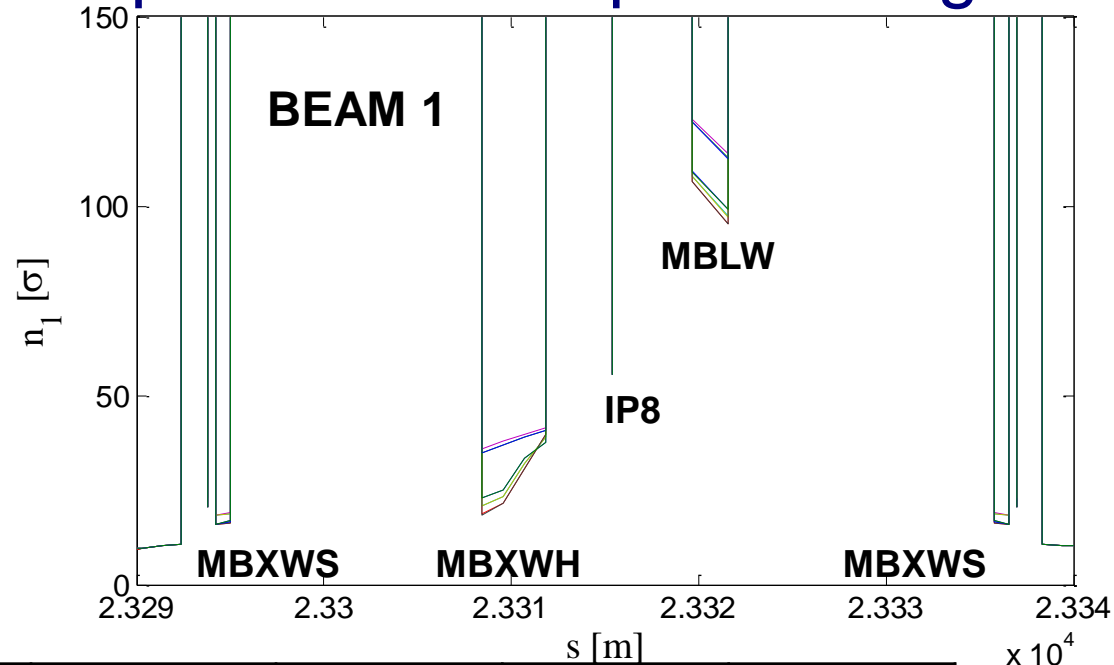

Equipment	n_1 nominal [σ]	n_1 full [σ]	n_1 nominal [mm]	n_1 full [mm]	n_1 nominal [%]	n_1 full [%]
BPMSW.1L8	20	20	14	14	45	45
MBXWS.1L8	16	16	10	10	40	40
MBXWH.1L8	34	19	12	6	45	24
IP8	56	56	16	15	52	52
MBLW.1R8	111	95	37	31	58	50
MBXWS.1R8	16	16	10	10	40	40
BPMSW.1R8	20	20	14	14	45	45

VErtex LOcator in LHCb

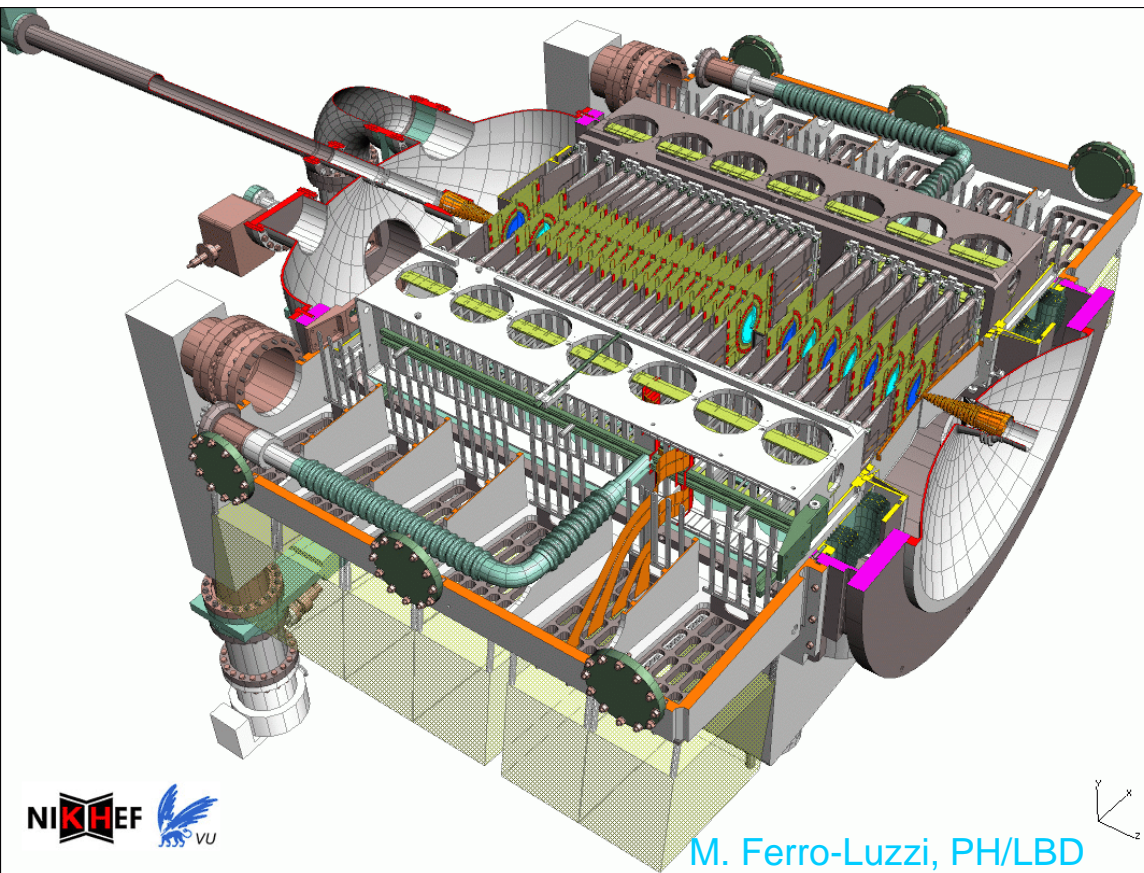

- Used for precise localization of track coordinates close to the interaction region in order to reconstruct production and decay vertices of b-hadrons
 - Surrounding IP8 (from $\sim 0.35\text{m}$ left to 0.75m right)
 - Series of retractable silicon sensors closing down to an aperture of 5mm radius
- Sensor boxes can be centered around the beam by moving laterally (by 30mm) and up or down (by 5mm)
 - Ability to locate precisely the beam position from beam gas events

Simple considerations regarding aperture

J. Van den Brand, PH/ULB

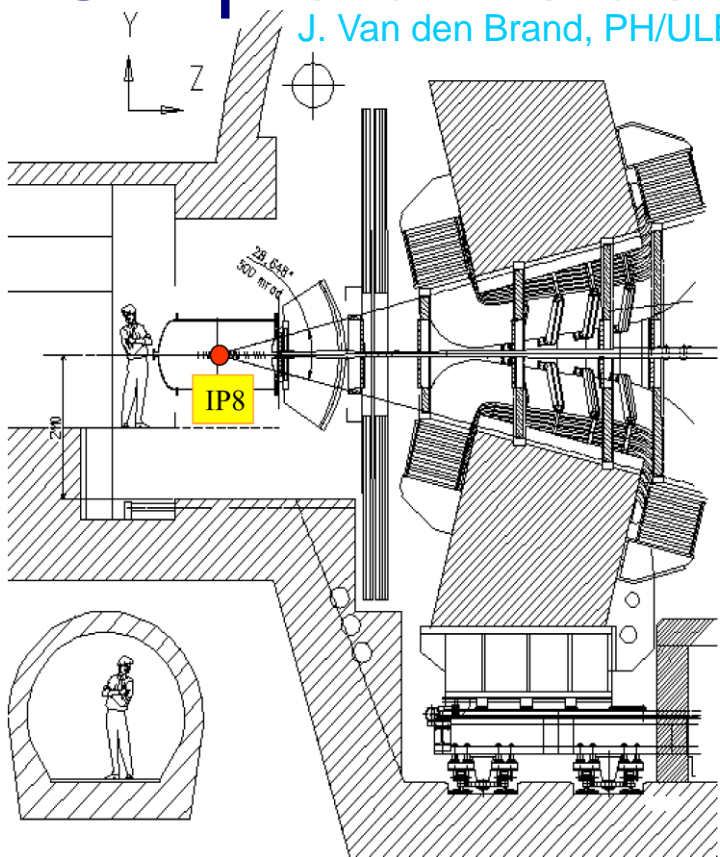

- β -function of 10.07m at right side of VELO
- Beam size of **0.28mm** at injection (**0.07mm** at collision)
- VELO minimum aperture of **5mm** corresponds to **18σ** (as compared to **72σ** at collision)
- **7σ** tolerance corresponds to **2mm** (**0.49mm @ 7TeV**)
- For nominal crossing angle of **$\pm 135\mu\text{rad}$** , horizontal displacement of **0.1mm** at VELO's right edge (**0.4σ**)
- For nominal crossing angle of **$\pm 135\mu\text{rad}$** , horizontal displacement of **0.1mm** at VELO's right edge (**0.4σ**)
- Peak orbit tolerance of **4mm** corresponds to **14.3σ**
- “Magnet”-type mechanical tolerance of **2.2mm** corresponds to **7.7σ** (realistic tolerance of **0.2mm**)

Closure of the VELO for different scenarios

Internal crossing angle [mrad]	VELO aperture at collision	VELO aperture with loose mechanical tolerances [mm]		VELO aperture with tight mechanical tolerances [mm]	
	With CO tol. of 3mm	With CO tol. of 4mm	Without CO tol.	With CO tol. of 4mm	Without CO tol.
2.1	-	11.1	7.1	9.1	5.1
0.135	4.0	9.6	5.6	7.6	3.6
-2.1	-	11.2	7.2	9.2	5.2
-0.135	4.1	9.7	5.7	7.7	3.7
0	4.0	9.6	5.6	7.6	3.6

* Minimum VELO closure at 5mm radius

- The VELO apertures quoted allow $n_1 = 7\sigma$
- They are computed for no separation and external crossing angle
 - Influence of the separation important mostly for small internal crossing angles
 - Influence of the external crossing angle is minimal
 - Different spectrometer polarity has a minor influence in the available aperture
 - Between the nominal and extreme crossing angle the difference is around 1.5mm

■ For the **loose** mechanical tolerance of **2.2mm**

- For nominal internal crossing angle, the VELO cannot be closed to less than **9.6mm**
- After centring it around the CO, it can be closed down to **5.6mm** (for no internal crossing angle) or to **7.1-7.2mm** for extreme crossing angle

■ For a **tight** mechanical tolerance of **0.2mm**, 2mm can be gained for all quoted values

- The VELO can be closed down to **5.0mm** for an internal crossing angle of **~2mrad**

■ The precision with which the detector can be centred around the beam is determinant

Compensator failure considerations

■ Time needed for compensator magnet failure, with simple exponential current decay, to create maximum orbit distortion of 1σ (2σ for dashed lines) as a function of the internal crossing angle (from nominal $N=1$ to extreme for $N=16$)

■ **Hundreds of ms** for nominal crossing angle

■ **Tens of ms** for extreme crossing angle

■ **Extreme** power converter failures may further reduce the time (need of Fast Current Change Monitors – only in MBXWT up to now)

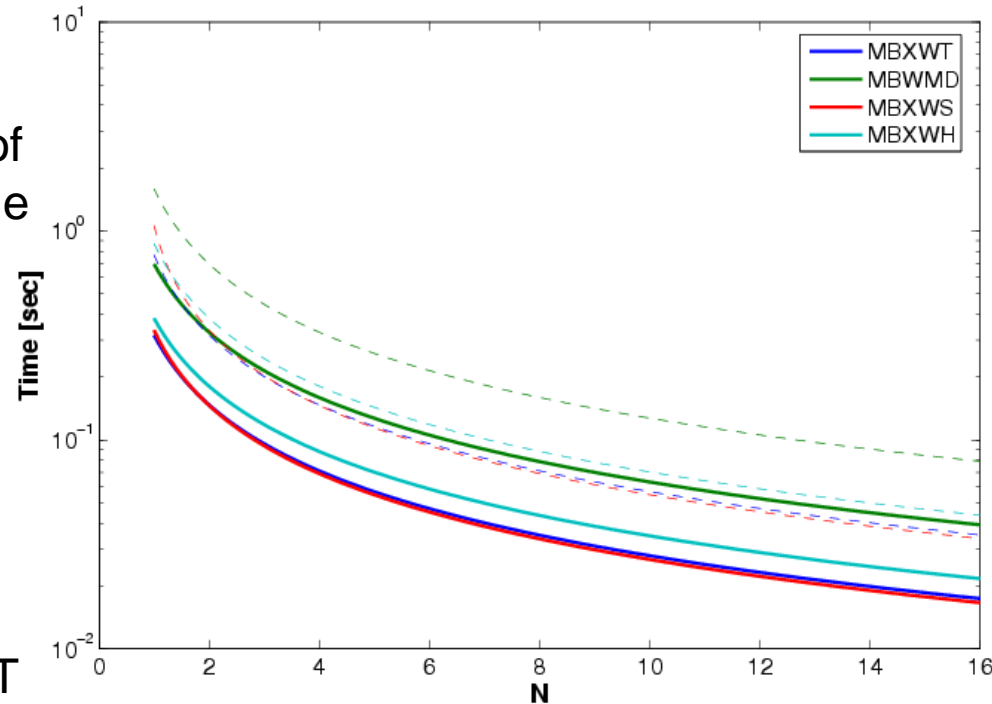

A. Gomez-Alonso,
AB/CO

	Injection (450 GeV)							
	β_{col} [m]	β_{magnet} [m]	Short circuit		Constant dl/dt		Max ΔV	
			t for 6σ [ms]	t_{loss} [ms]	t for 6σ [ms]	t_{loss} [ms]	t for 6σ [ms]	t_{loss} [ms]
MBAW	392	23	Not reached	17845.71	44204.57	19326.21	687.26	294.62
MBWMD	392	19	Not reached	2409.44	26632.68	11643.79	157.38	67.82
MBXWT	392	55	10117.97	625.40	7119.79	3112.77	17.39	7.57
MBLW	342	14	28026.42	5446.31	21765.68	9515.94	426.07	184.13
MBXWH	342	11	Not reached	1572.32	32303.82	14123.21	47.34	20.54
MBXWS	342	55	Not reached	Not reached	64241.49	28086.34	30.71	13.25

Operational and machine protection issues

- Main limitations in the aperture of 2nd compensator for both IR2 and 8. Although $n_1 > 7\sigma$, available aperture quite small, especially in IR8
 - **MBWMD** (IR2) with n_1 of **9mm** (with respect to **14mm**)
 - **MBXWH** (IR8) with n_1 of **6mm** (with respect to **12mm**)
- It is advisable not to inject with extreme bump in place, for ensuring protection of experimental areas in case of failures
 - During early commissioning stages, machine optics may be far from nominal values considered in aperture estimations
 - LTC recommendation for performing the corresponding beam optics measurements may not be feasible due to limited amount of commissioning time
- With extreme bump amplitude, VELO can be closed to around **5.1-5.2mm**, depending on precision with which beam can be located and mechanical detector tolerances
 - With VELO open, a precise estimation of the beam position not straightforward
 - 5mm mechanical half-aperture is extremely small, if not the smallest around the machine (depending on the closure of collimators)
 - VELO protection against equipment failures or beam distortions has to be discussed
- Fast Current Change Monitors needed for failure protection of all spectrometer compensator magnets