

Beam Presence Flag Changes

Technical Stop 3

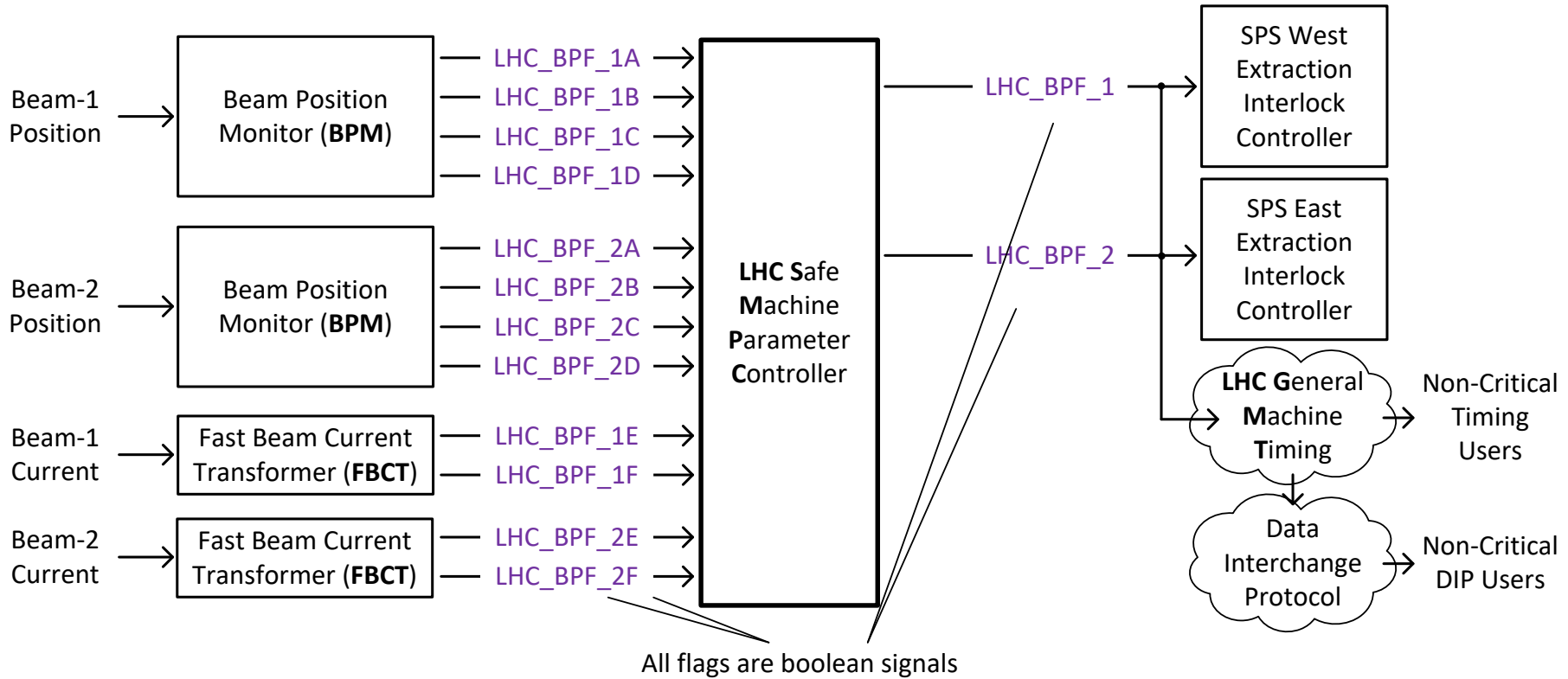

Implementation

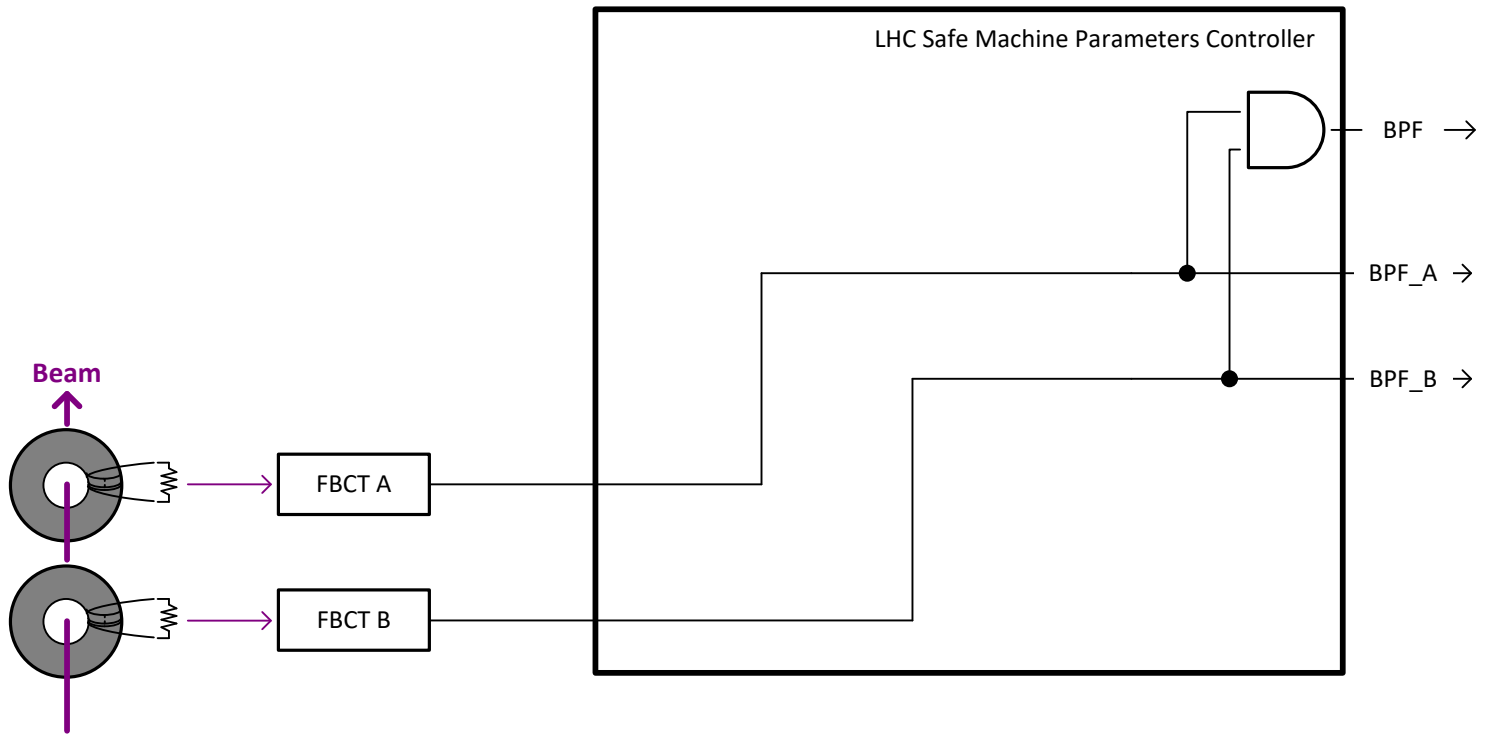

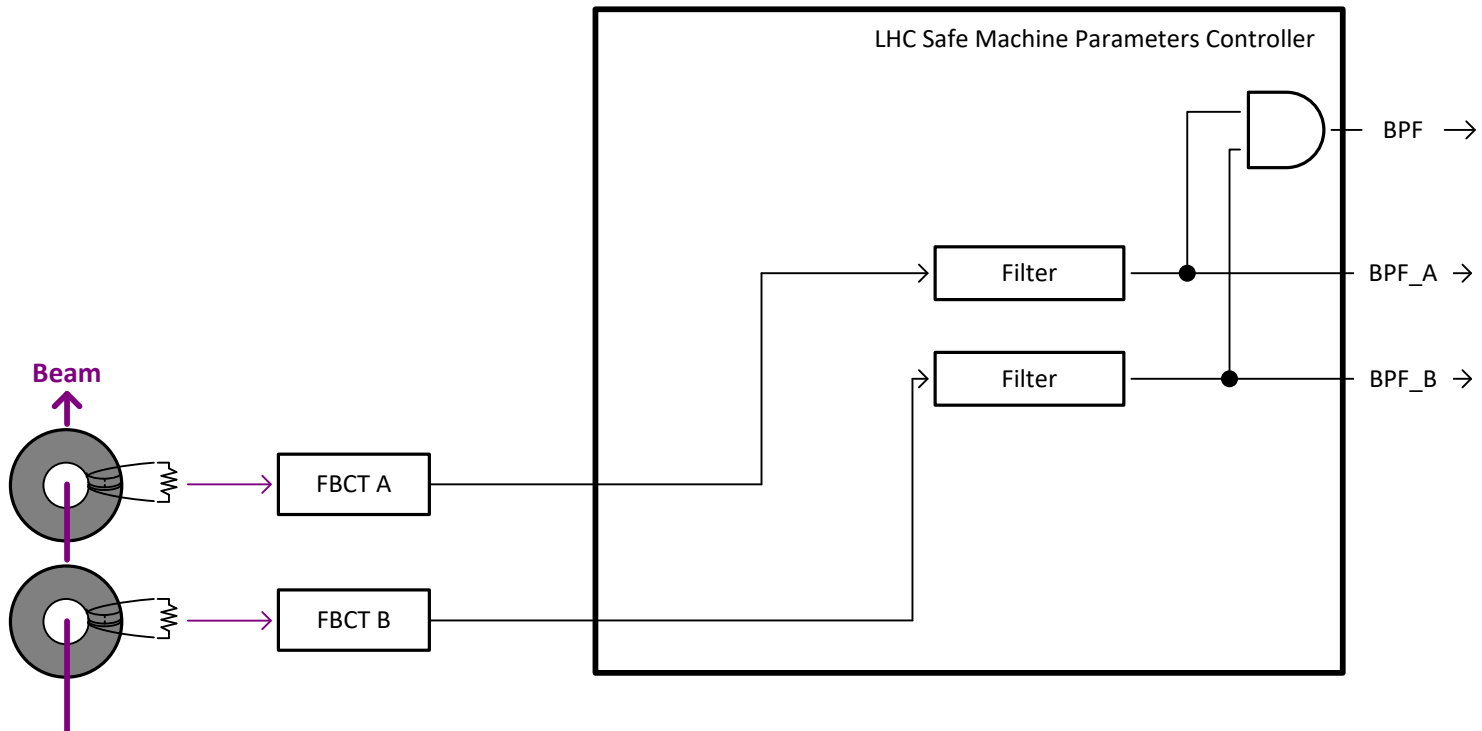

EDMS# 1070143

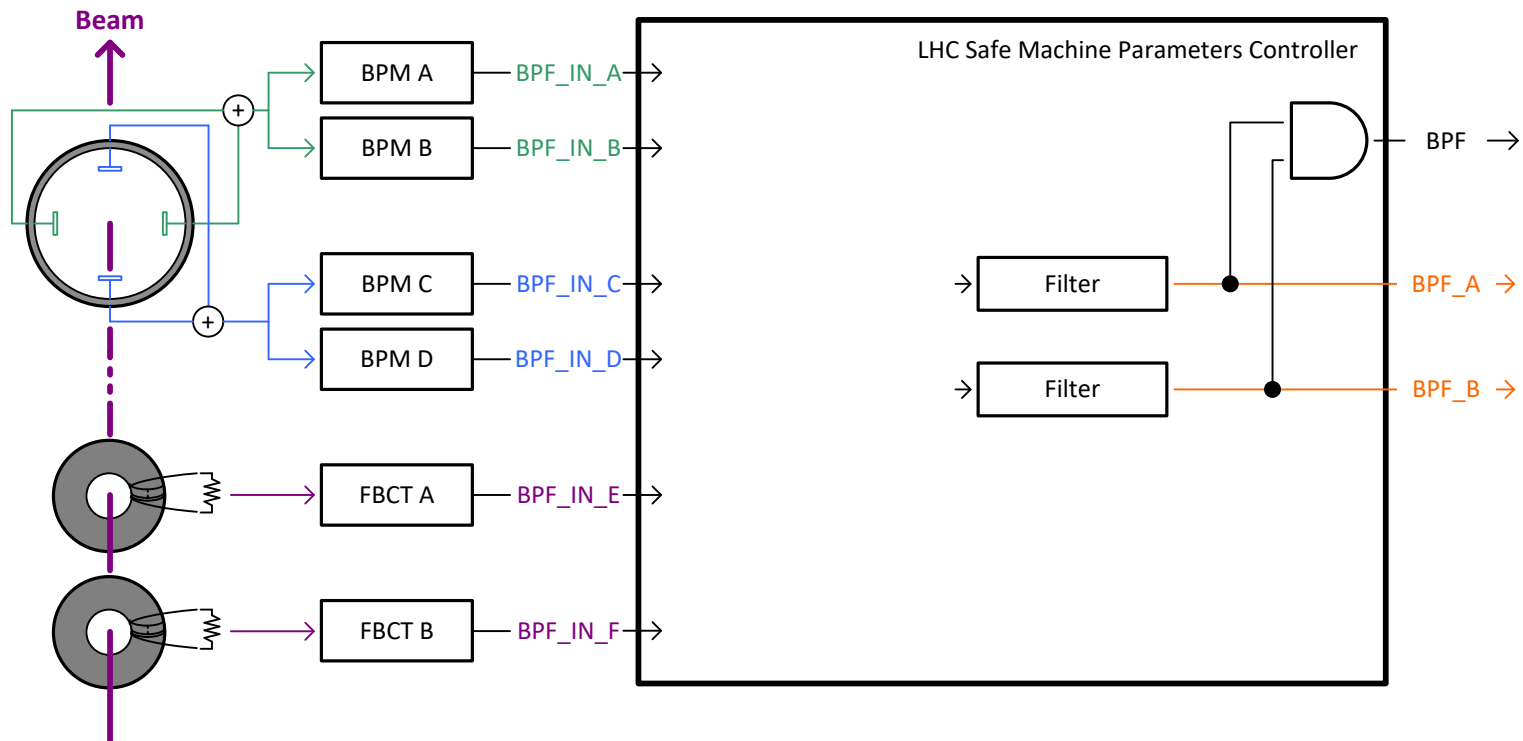

EDMS# 1096447

< 1e9 = PRESENT

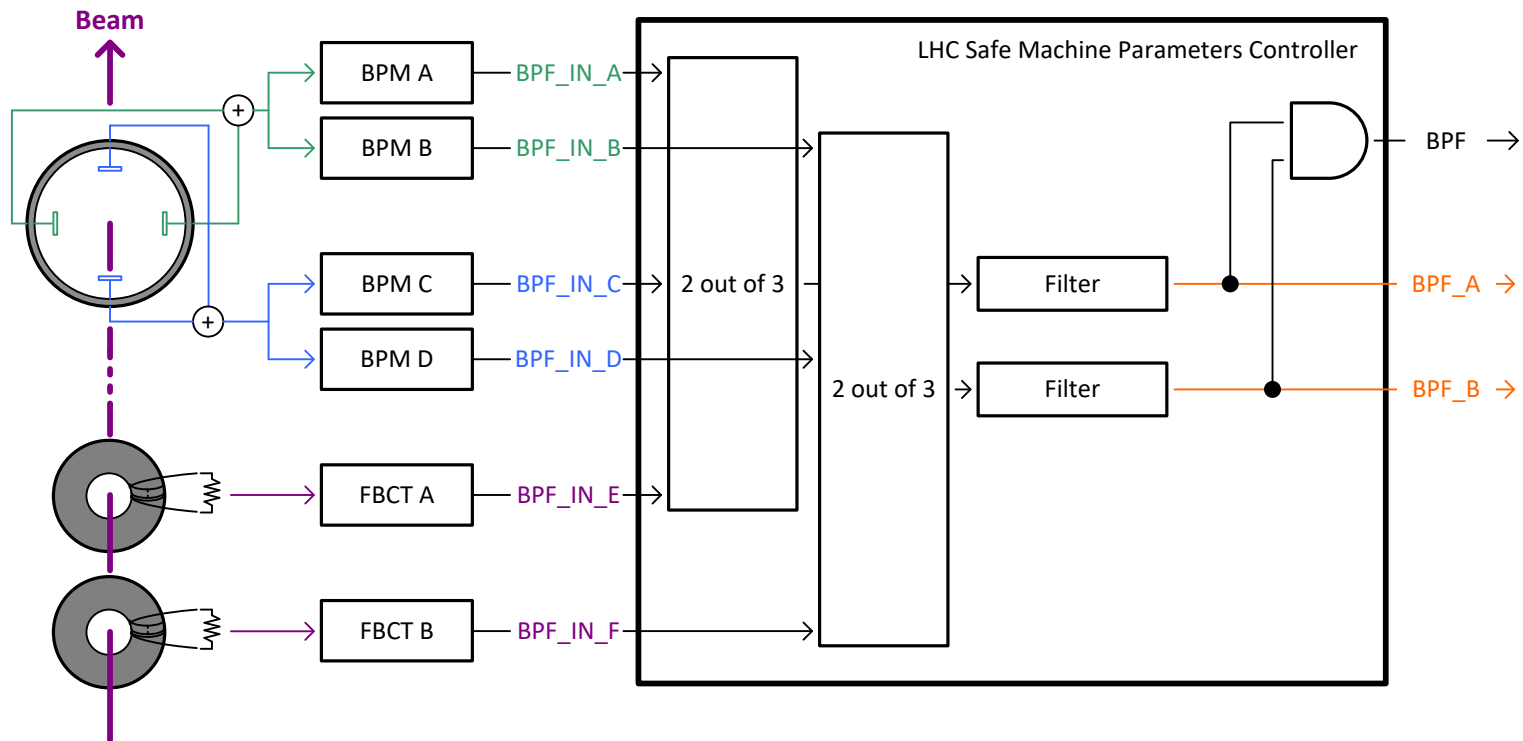

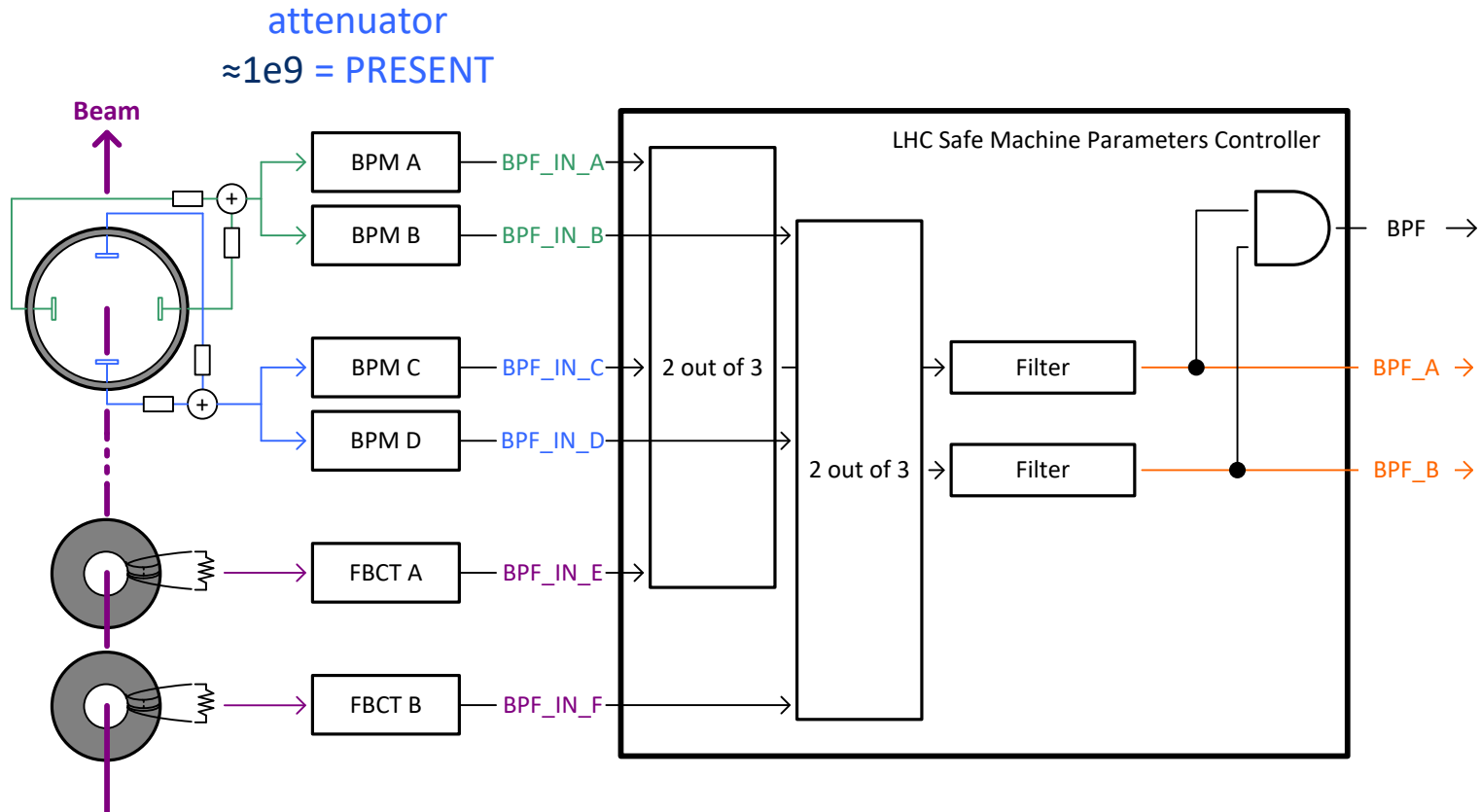

Characteristics

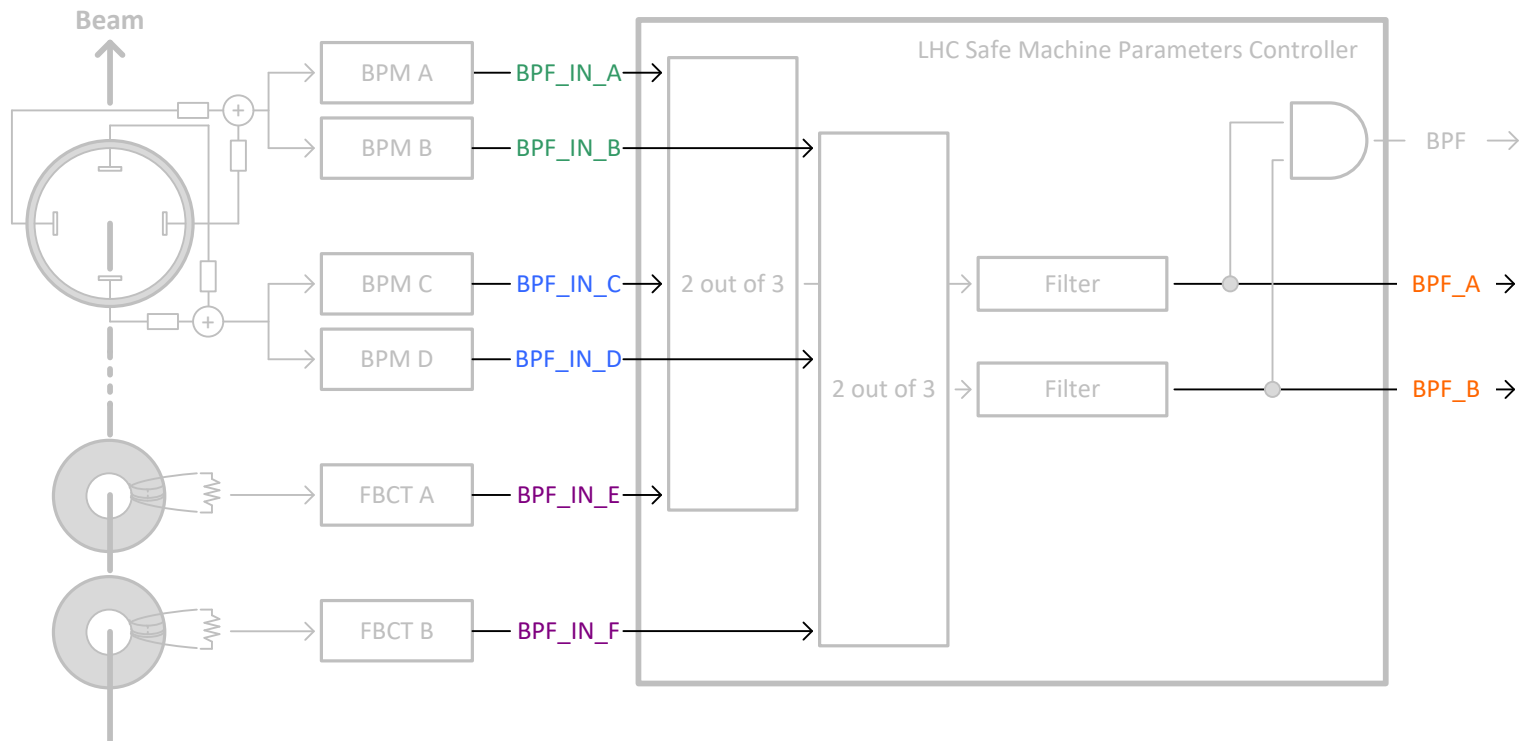

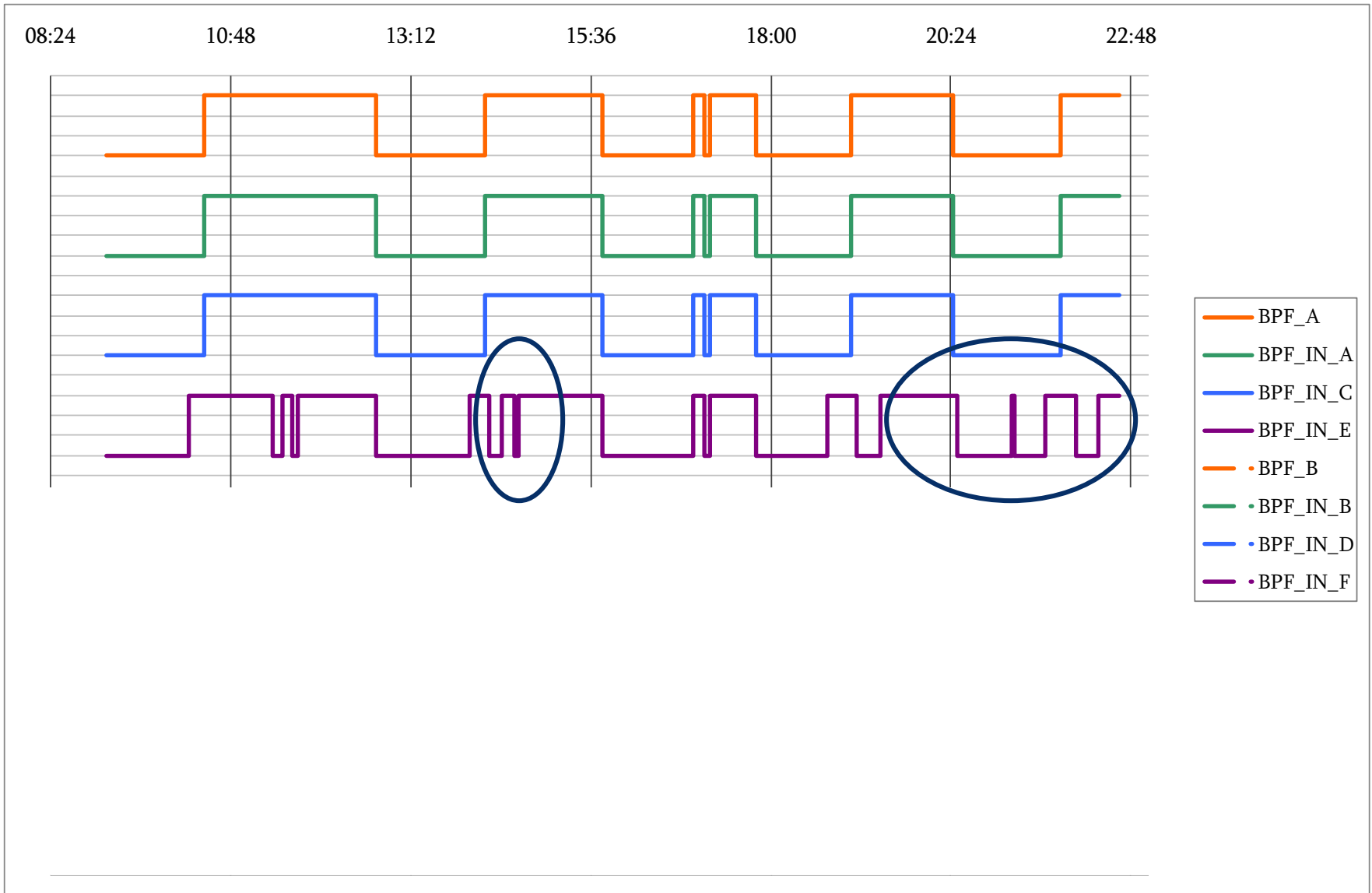

FALSE → TRUE (not critical)

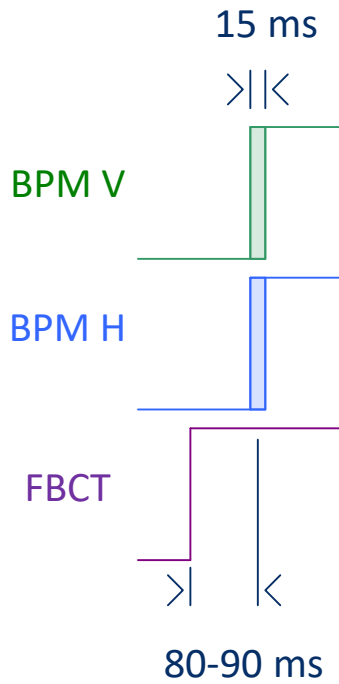

TRUE → FALSE (critical)

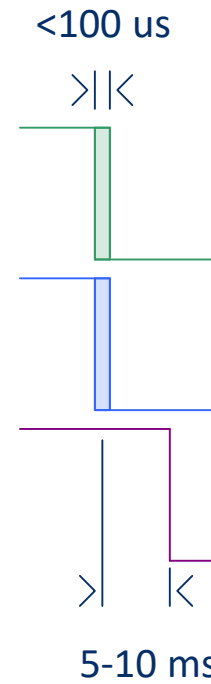

Changes

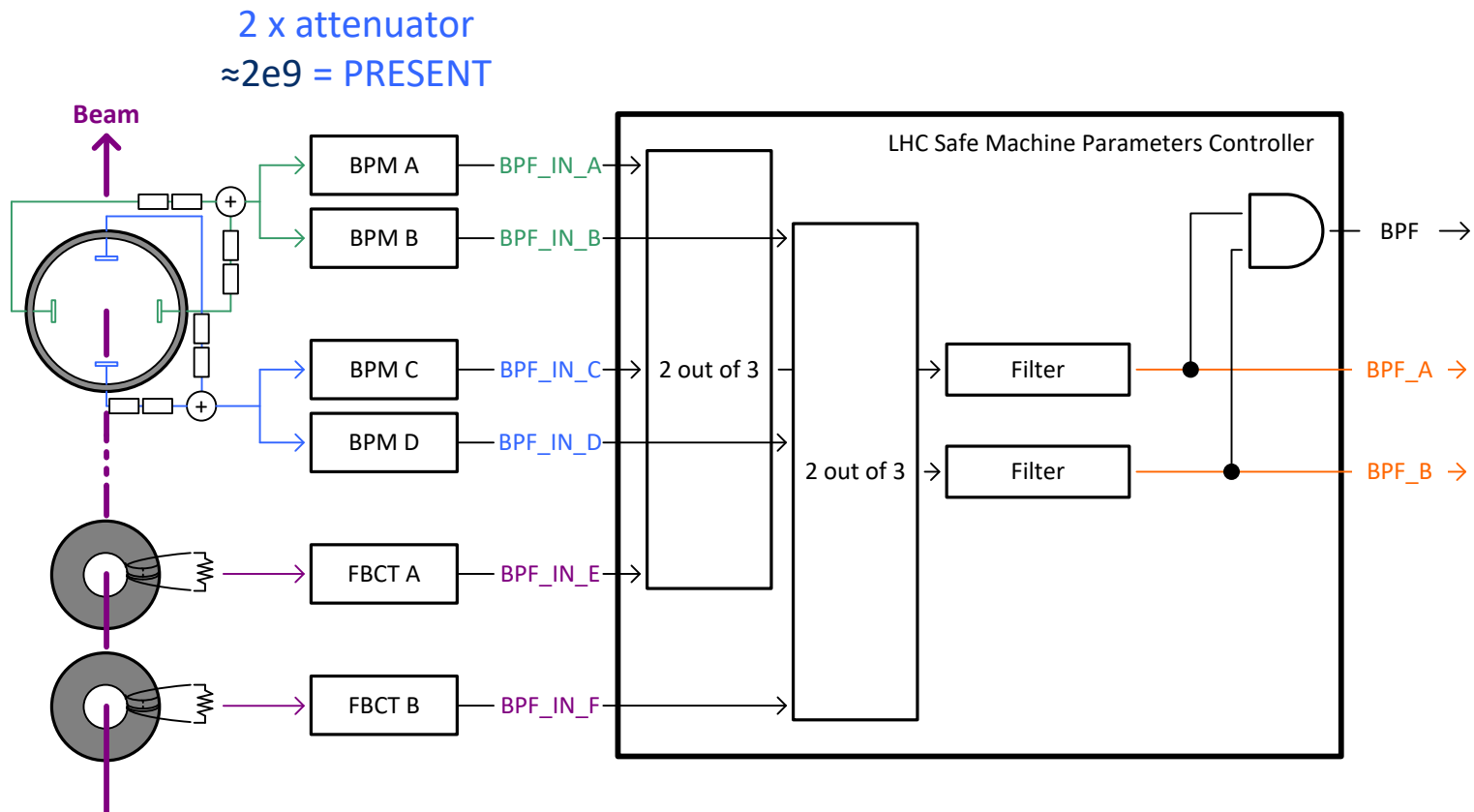

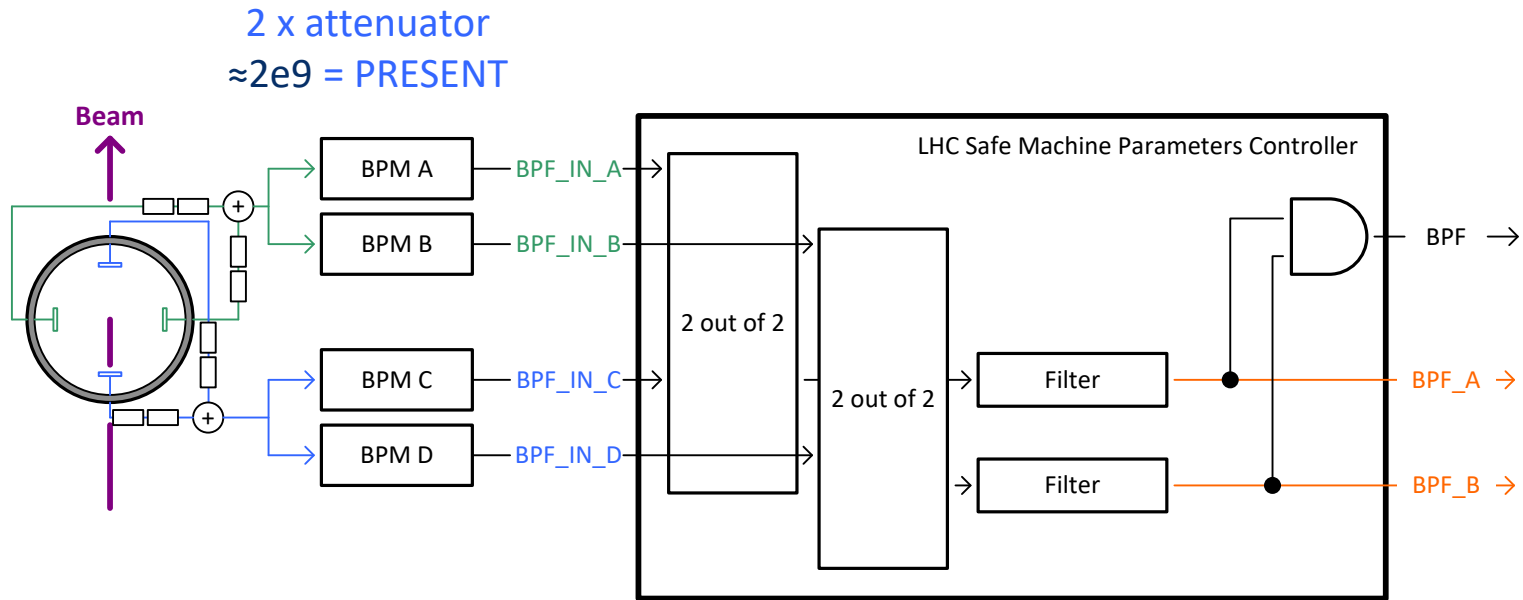

Disconnect FBCT

Increase BEAM_PRESENCE_LIMIT in dedicated BPM

>2e9 = PRESENT

remove FBCT input

+ disconnect in CCC (easy access)

+ BE/BI can develop

+ recover spares

+ only dedicated hardware

- only dedicated hardware

MPP view?