

Safe Machine Parameters
General Machine Timing
Cross-Check

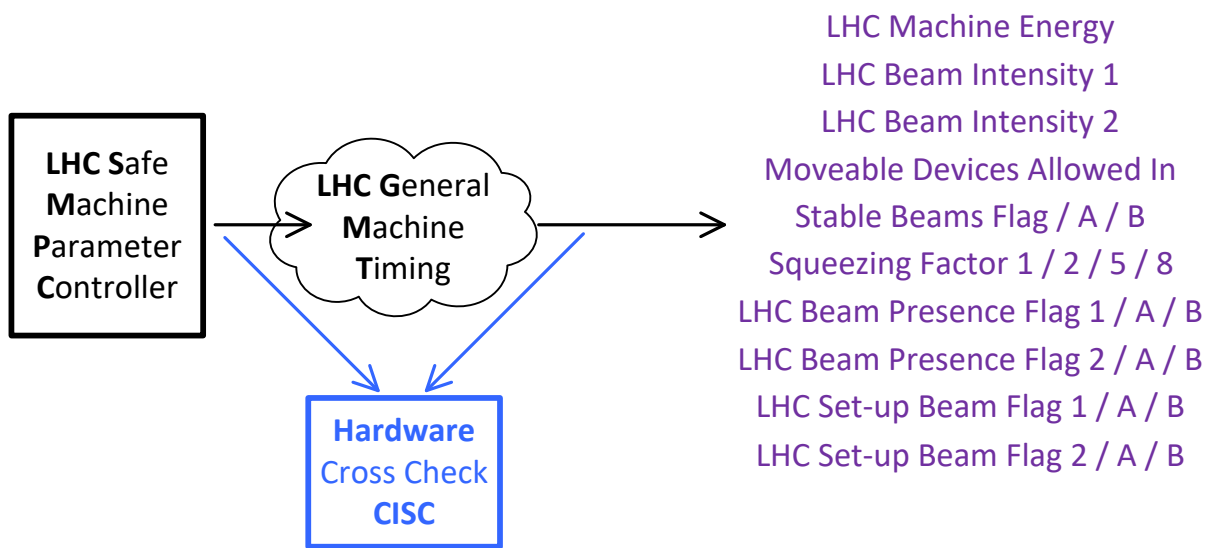
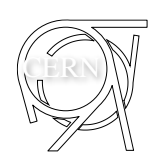

Safe Machine Parameters
Transmission

≠

General Machine Timing
Broadcast

Set-up Beam Flag stuck TRUE

Energy stuck at 450 GeV

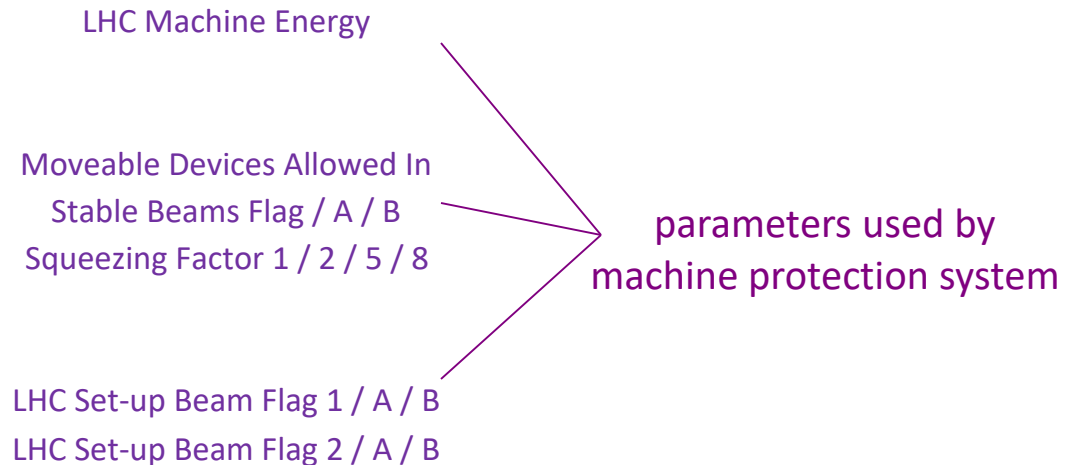

Cross-Checker Proposal

For each parameter \longrightarrow Record last 10 SMP transmissions
Compare with current GMT transmission \longrightarrow discrepancy = beam abort

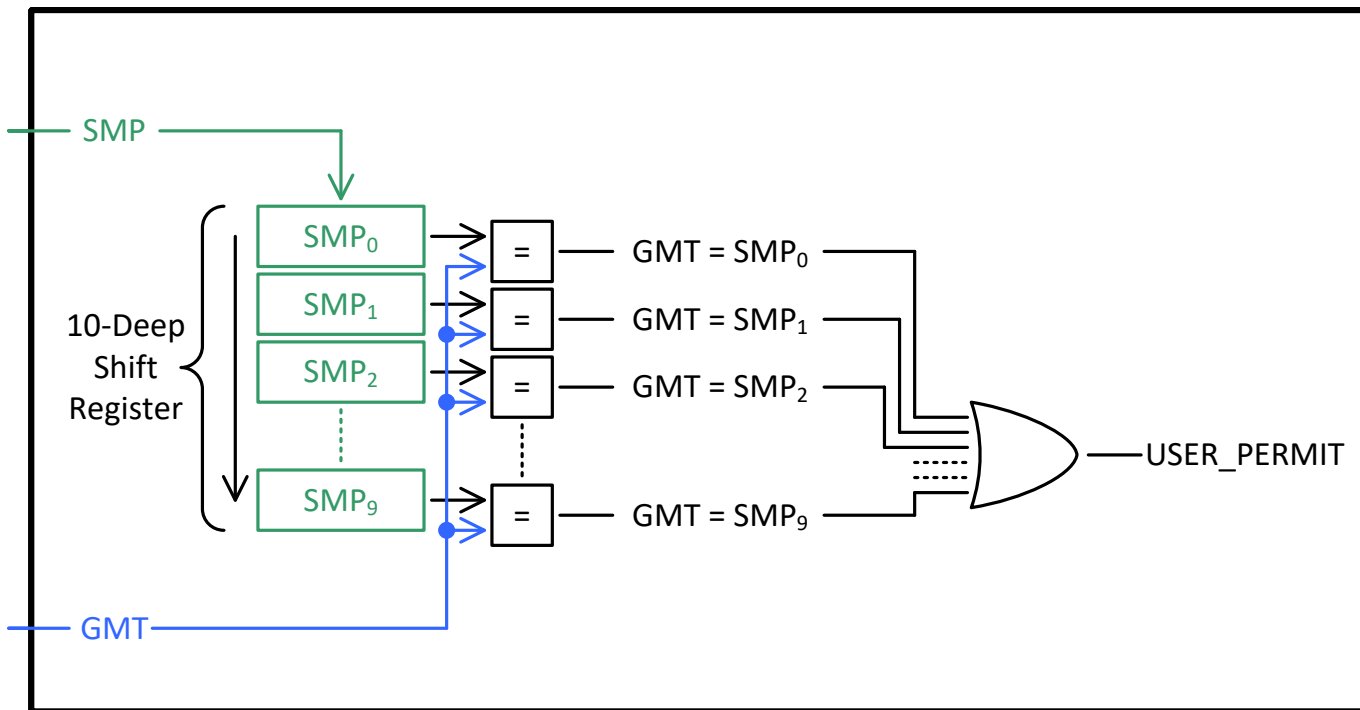

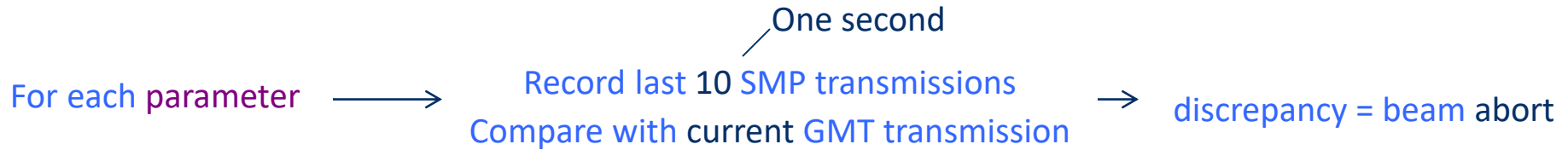

Solution will also check cable presence & parameter reception rate

- GMT can drop a parameter
- GMT can rearrange parameter transmission order
- GMT cannot change payload of parameter

Prototype February / March 2012 – Connect to BIS (disabled)
March / April 2012 – enable

Satisfactory for MPP?

fin – thank you!