

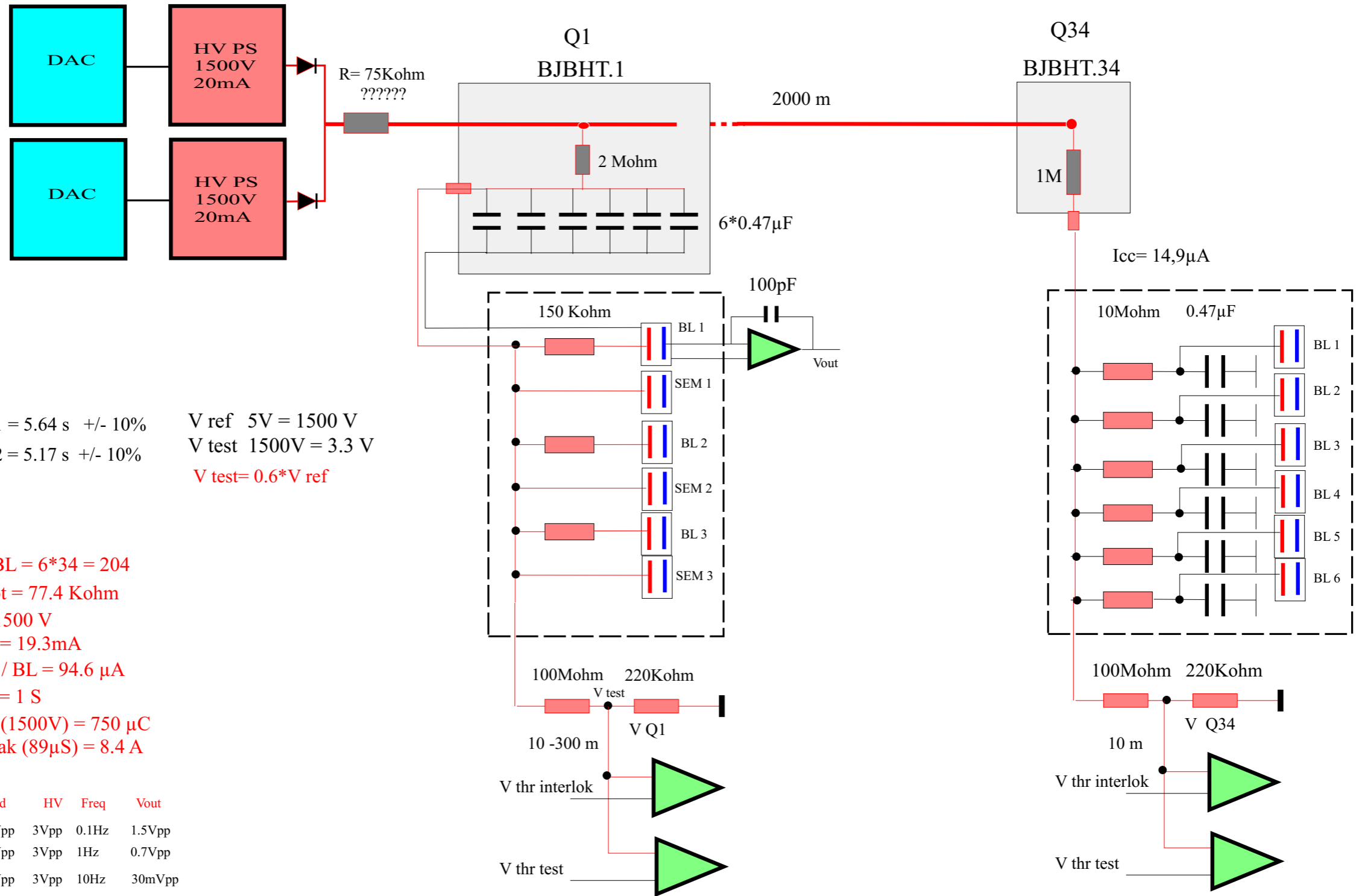

BLM – HV

E. Nebot del Busto for the BLM team

HV Set up.



Outlook

- Five cards have been found to be affected (BJBHT.A5R7, BJBHT.A6R7, BJBHT.C6R7 , BJBHT.D6R7, BJBHT.E6R7)
- Five cards in L7 symmetrically modified (BJBHT.A5L7, BJBHT.A6L7, BJBHT.C6R7 , BJBHT.D6L7, BJBHT.E6L7)
- Replacement of a resistor in the backplane of the CFC card reduce the threshold voltage to $\sim 950\text{ V}$ (from ~ 1440).
- Cards have been installed and tested in the tunnel.