

BIS channel to the LBDS re-triggering system

Stéphane Gabourin
TE/MPE-EP

MPP - 06 Dec 2012



Outline

LHC Beam Permit Loops

LBDS

- Synchronous Triggers
- Asynchronous Triggers

New BIS Asynchronous Trigger

Installation

BIS Generator (CIBG) upgrade

Questions



LHC Beam permits loops

Example for Beam 2
(Duplicated for Beam 1)

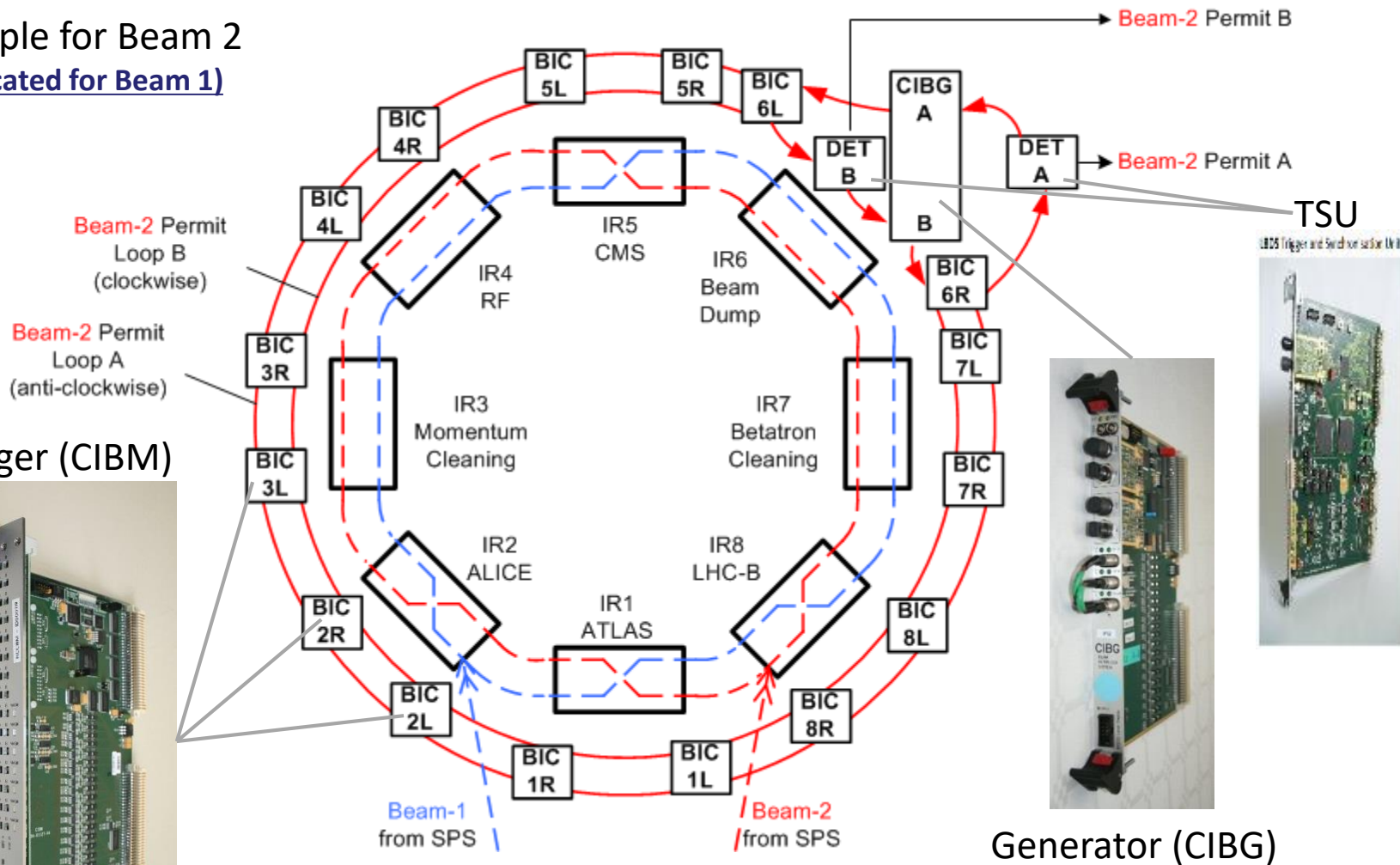

Manager (CIBM)



Generator (CIBG)



LBDS Synchronous Triggers 1/2

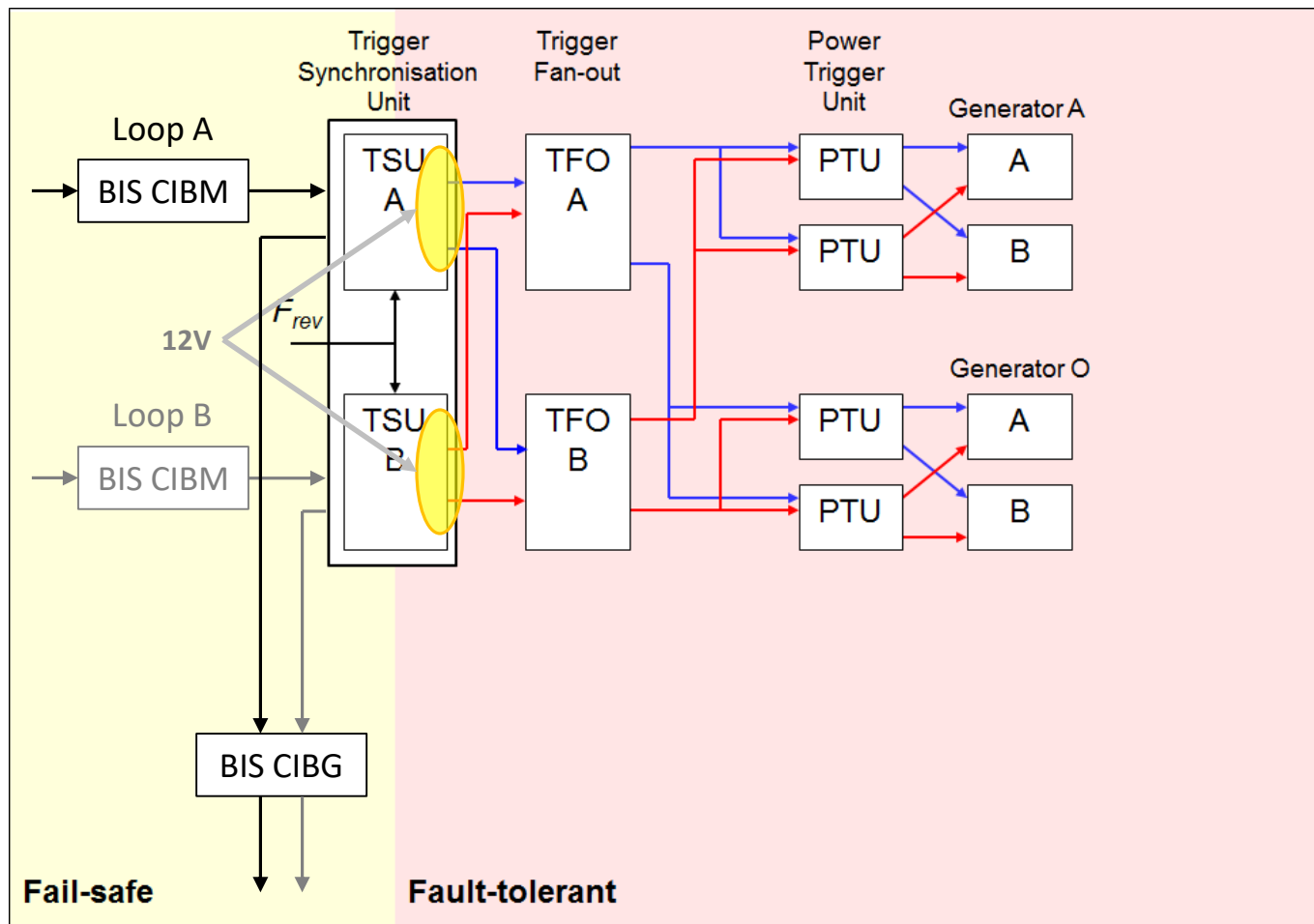

Courtesy E. Carlier

- Fully redundant Synchronous Beam Dump Triggers (SBDT)
- Except a common 12V line on VME bus of the TSU crate (will be solved during LS1)



LBDS Synchronous Triggers 2/2

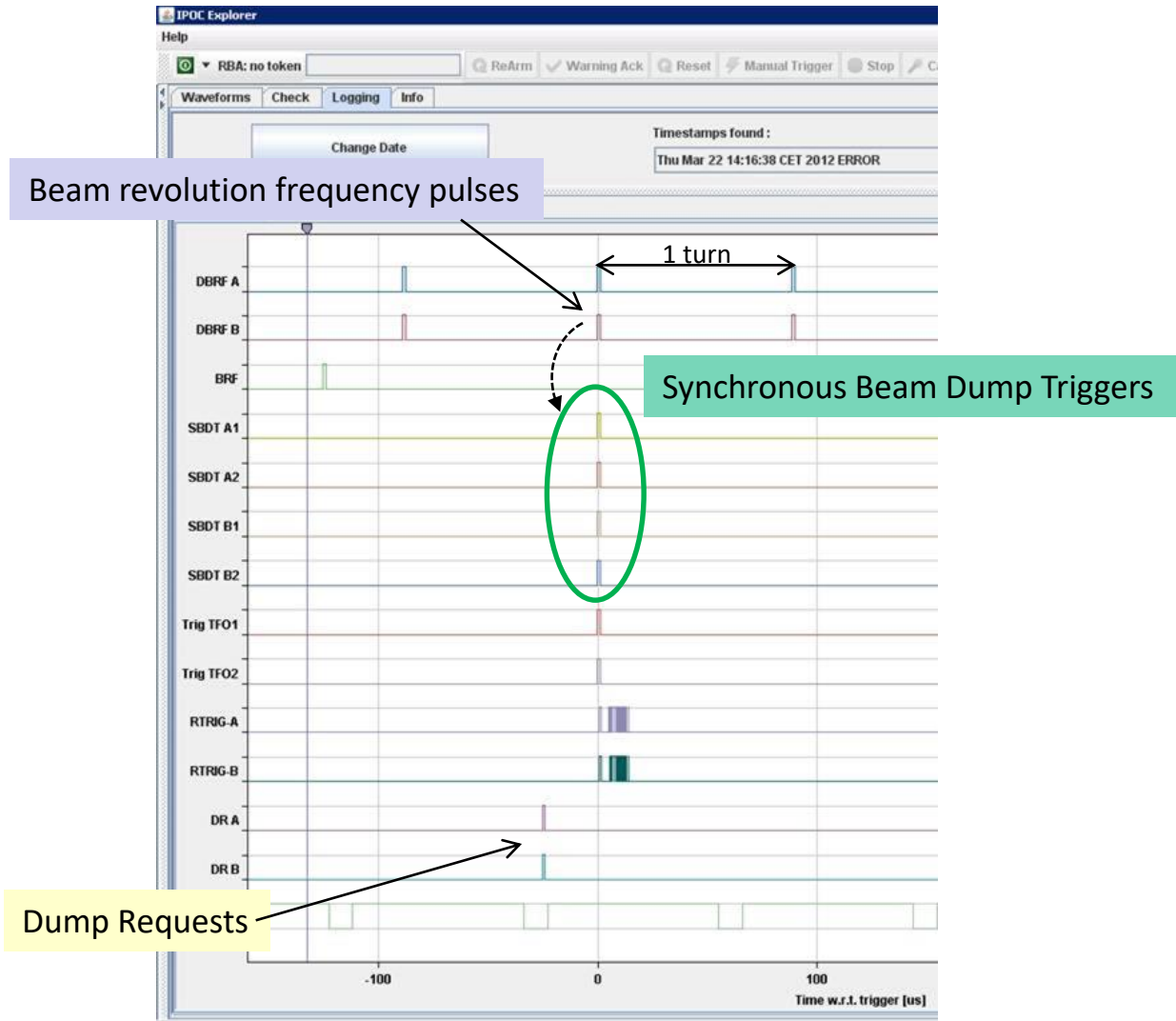

Courtesy E. Carrier

LBDS Asynchronous Triggers 1/2

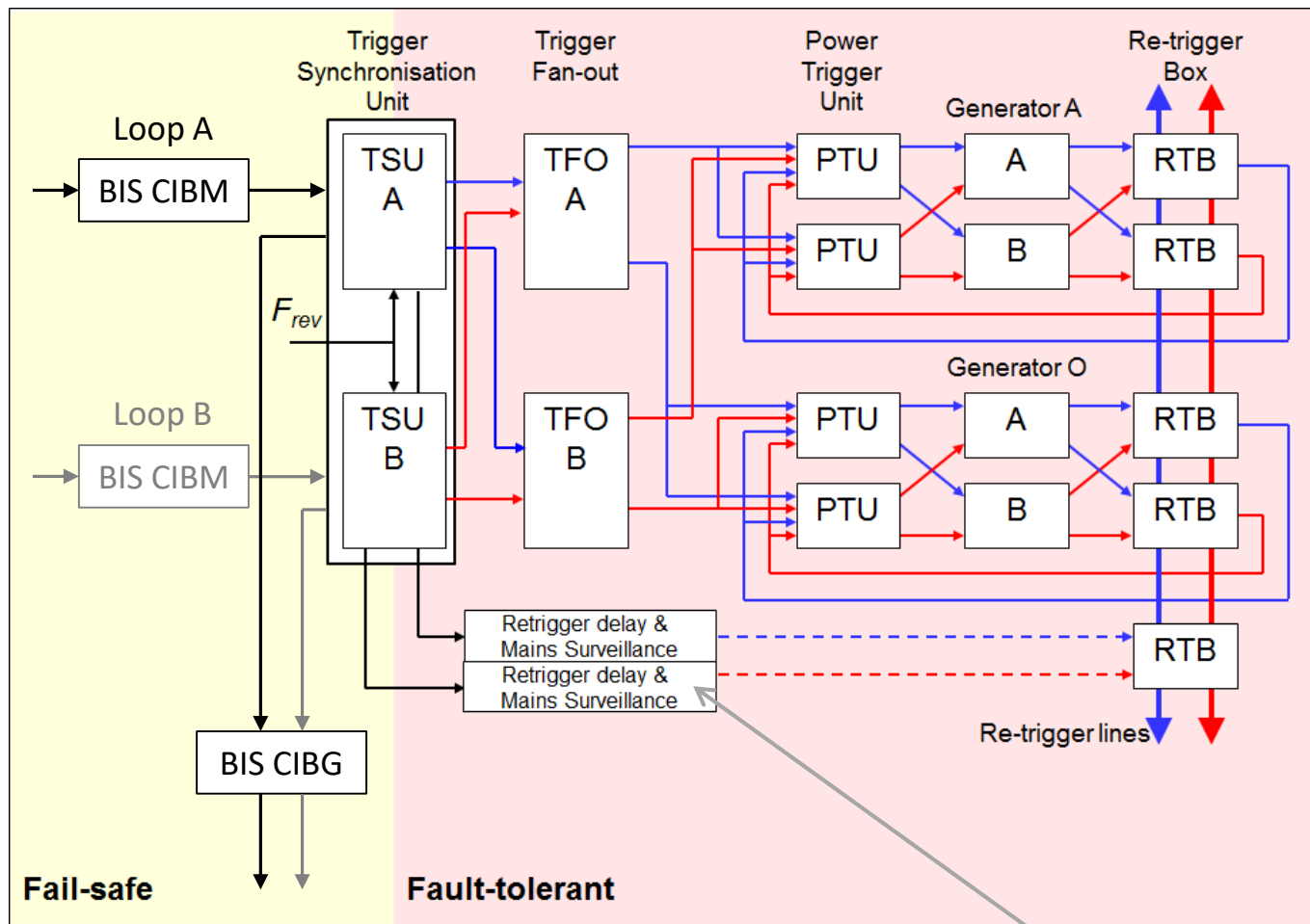

Courtesy E. Carrier

- Asynchronous Beam Dump Triggers (ABDT) **Trigger Delay (TD): 200us**



LBDS Asynchronous Triggers 2/2

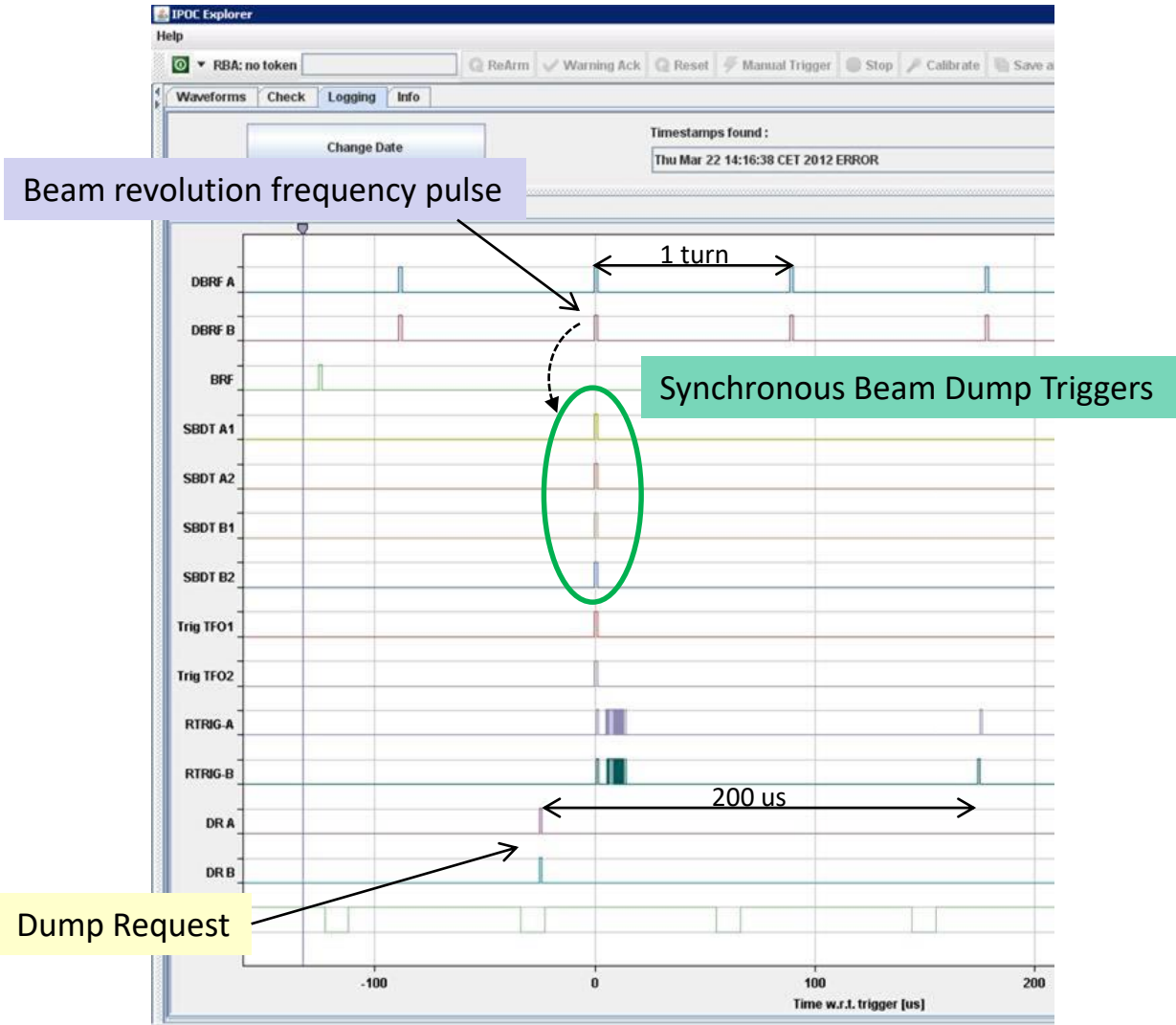

Courtesy E. Carrier



BIS 3rd channel: Asynchronous Trigger 1/2

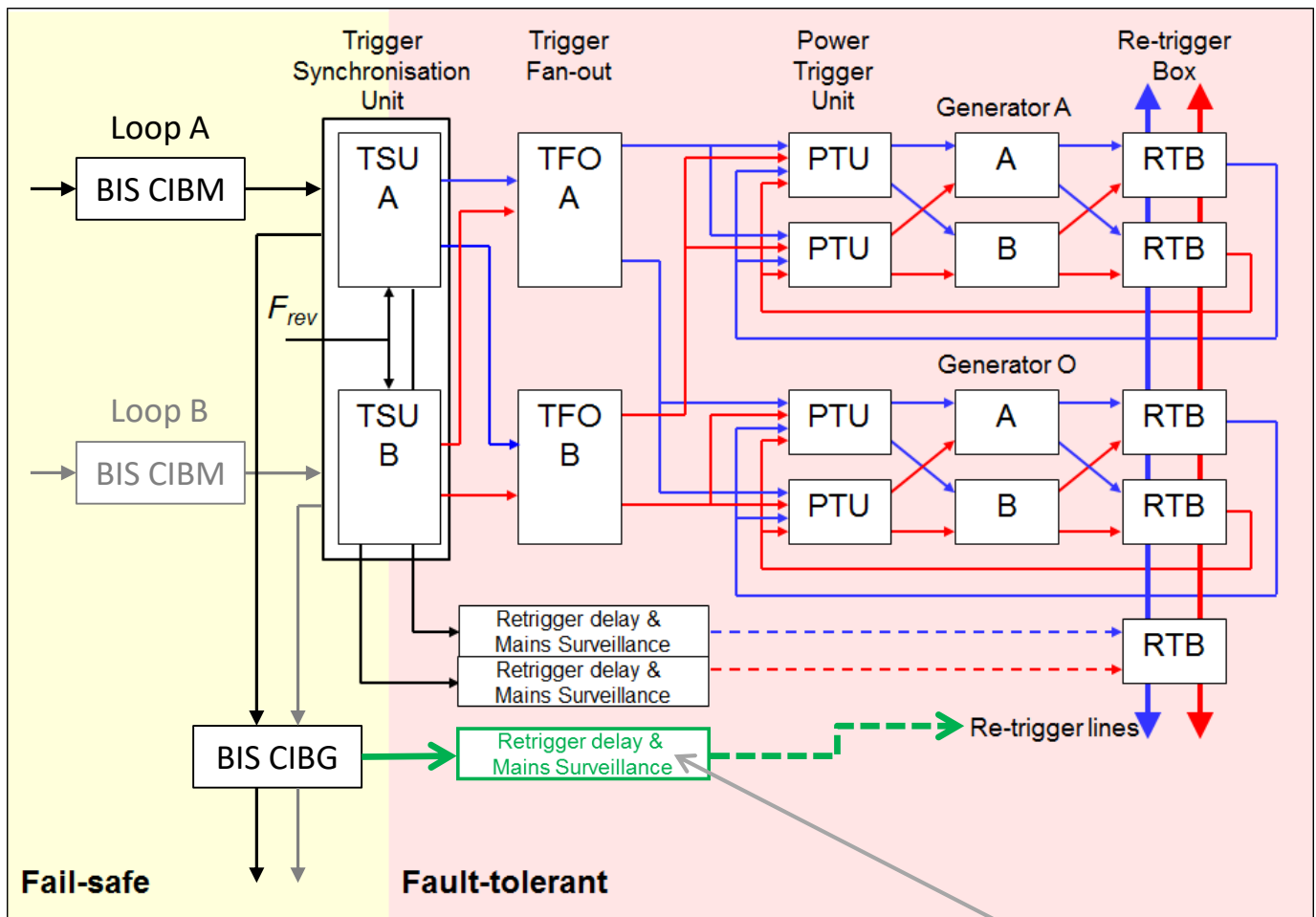



BIS 3rd channel: Asynchronous Trigger 2/2

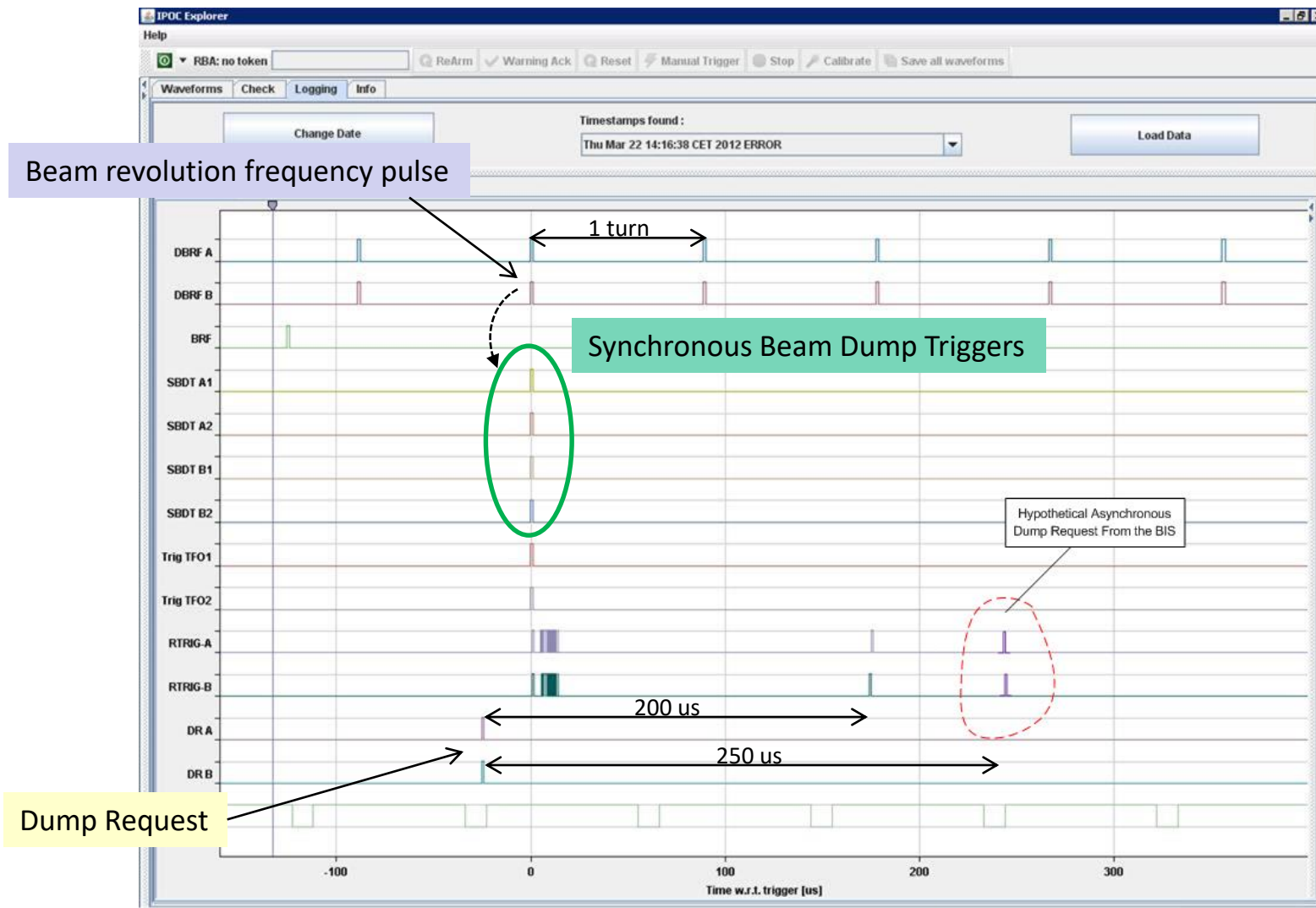

Courtesy E. Carrier

Installation

- TD to be installed in the BIC rack:
 - in **UA63** for Beam 1
 - in **UA67** for Beam 2
- Connection of the TD to the re-trigger line managed by TE/ADT group
- This trigger has to be delivered with **high availability and reliability**
- CIBG to be modified to provide the Asynchronous Beam Dump Trigger

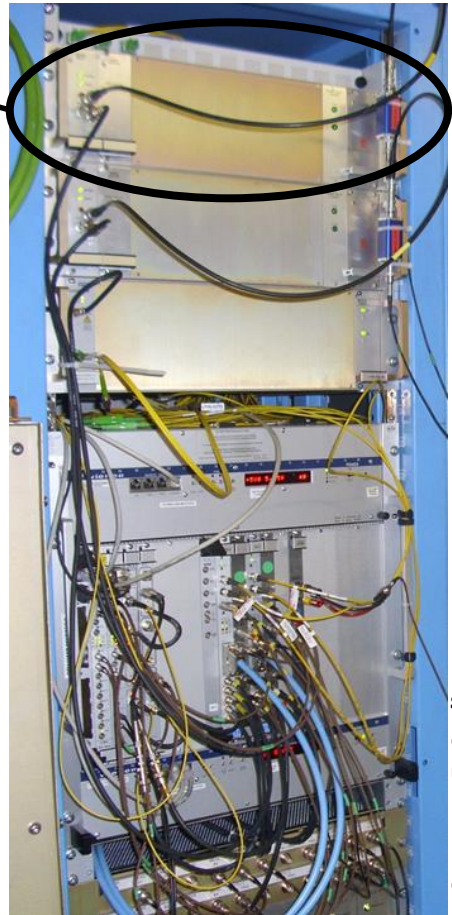
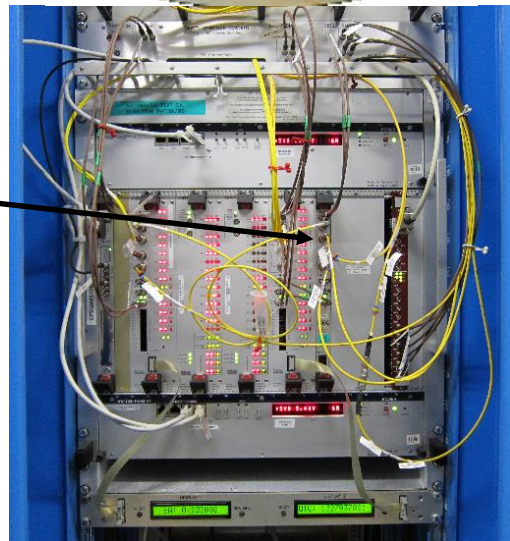
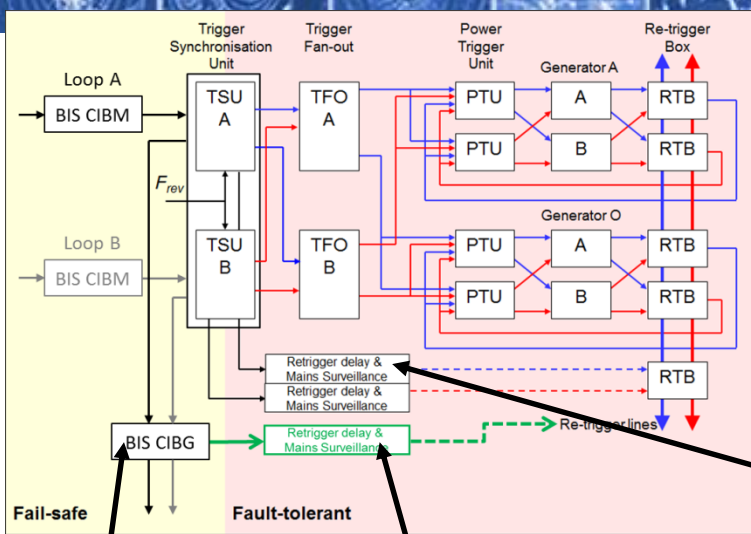

3rd Channel to add

=> Board to be redesigned

=> Replace digital components (obsolescence)

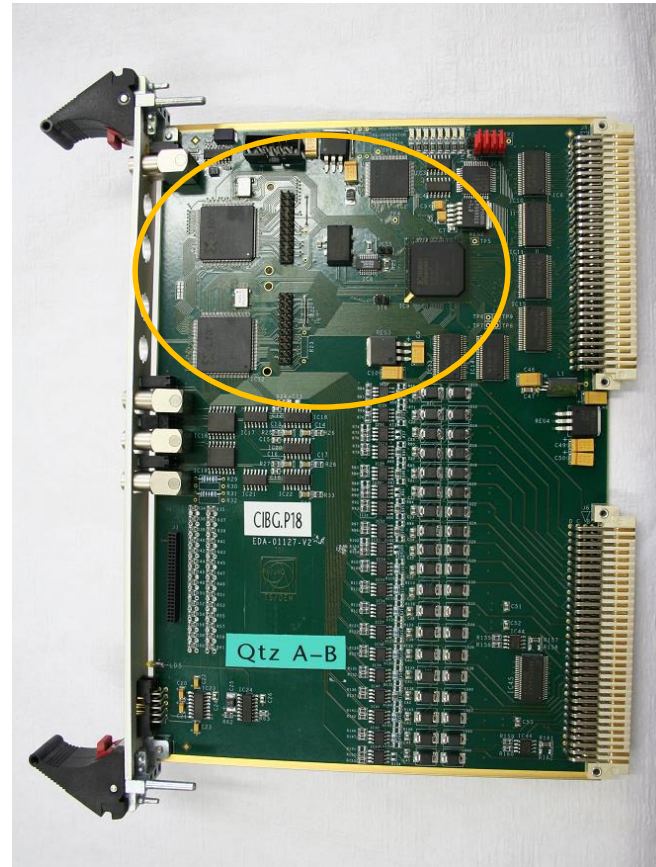



Questions

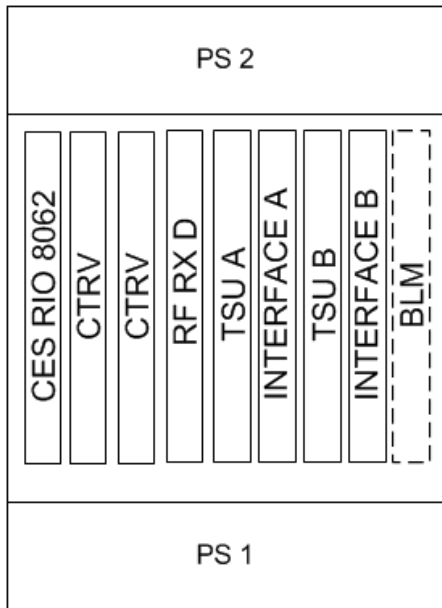
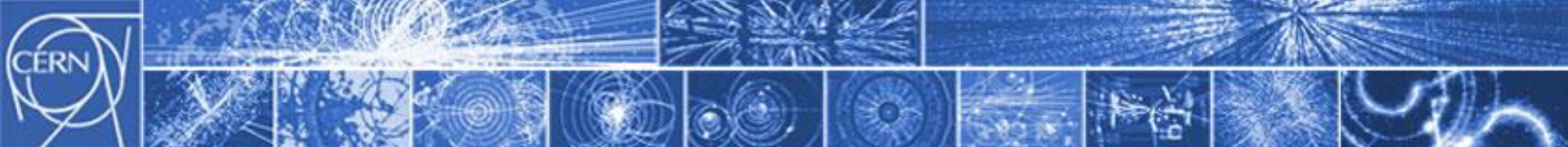

OLD



Fail-Safe system:
Prepulse
BRF B = 9.375 MHz
BLM

UPS B

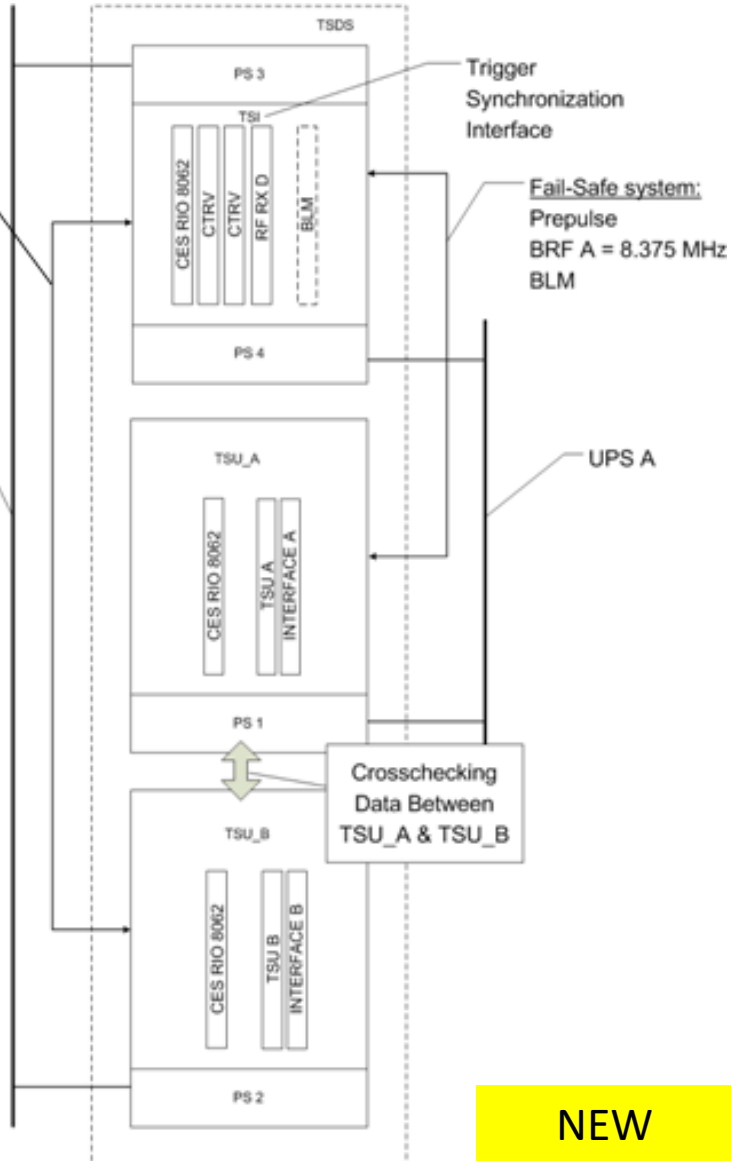

Fail-Safe system:
Prepulse
BRF A = 8.375 MHz
BLM

NEW

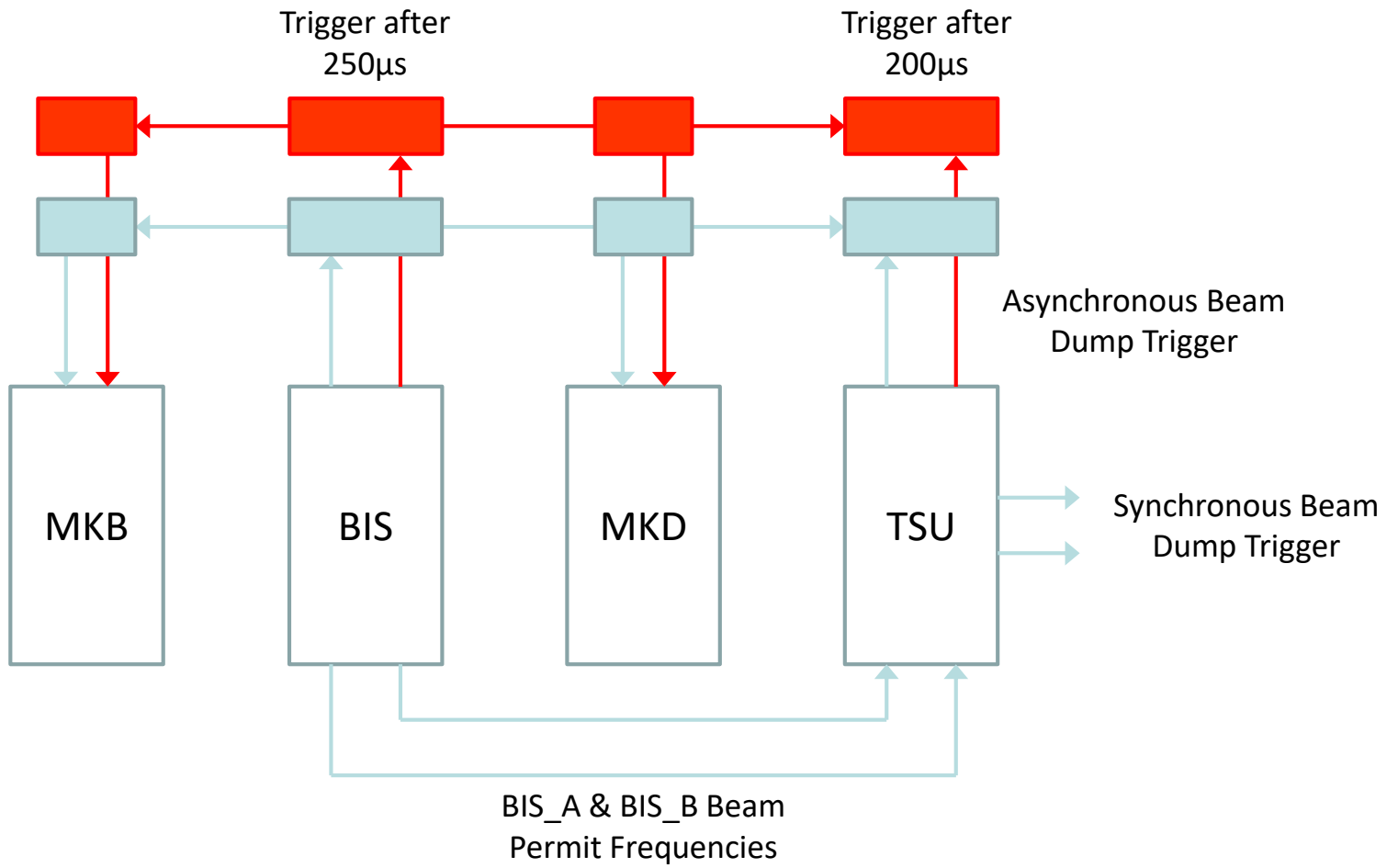

BEAM1
BEAM2

UA67
UA63

UA63
UA67

UA63
UA67

UA63
UA67