

TWEPP 2022 Abstract Submission: LHCb Scintillating Fiber detector front end electronics Test System

Figures and plots uploaded in addition to the summary

Figure 1: Overall diagram of the Test System

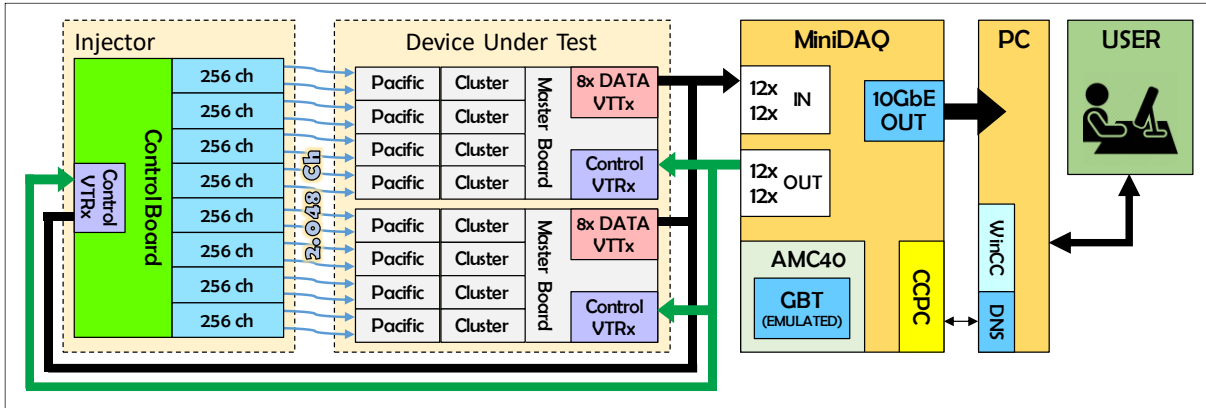

Figure 2: Illustration of the assembled modules in association with the overall diagram

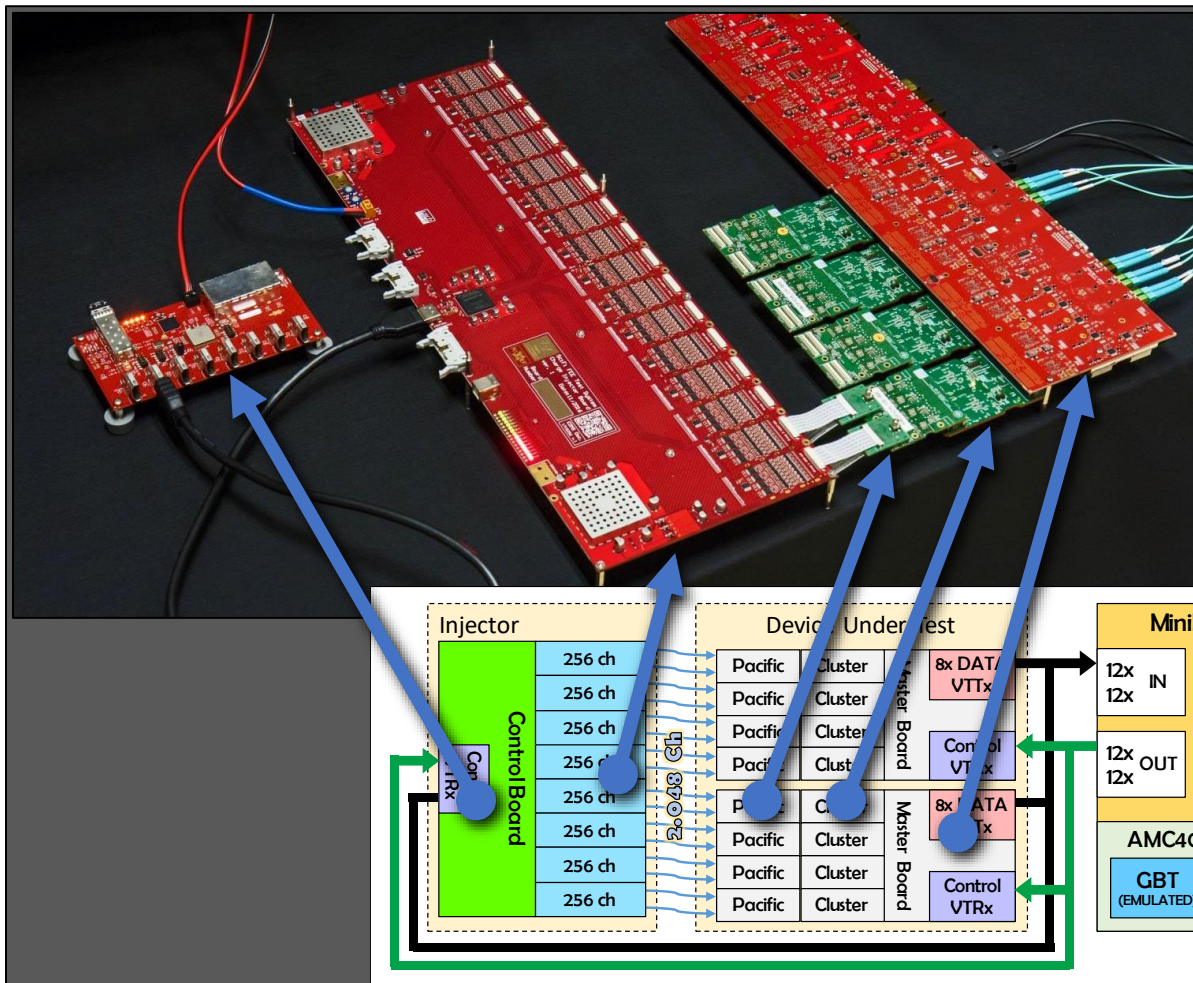

Figure 3: Conceptual diagram of the eight Injector Modules

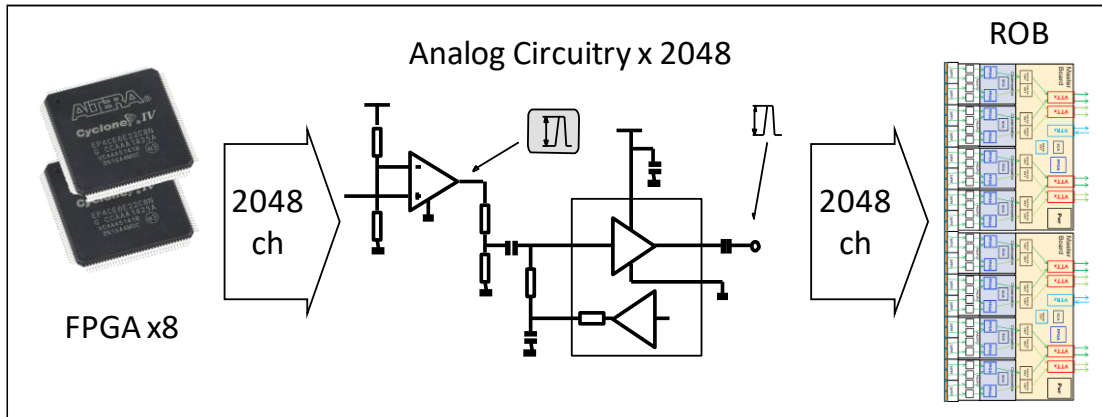

Figure 4: Photo of one of the Injector Modules

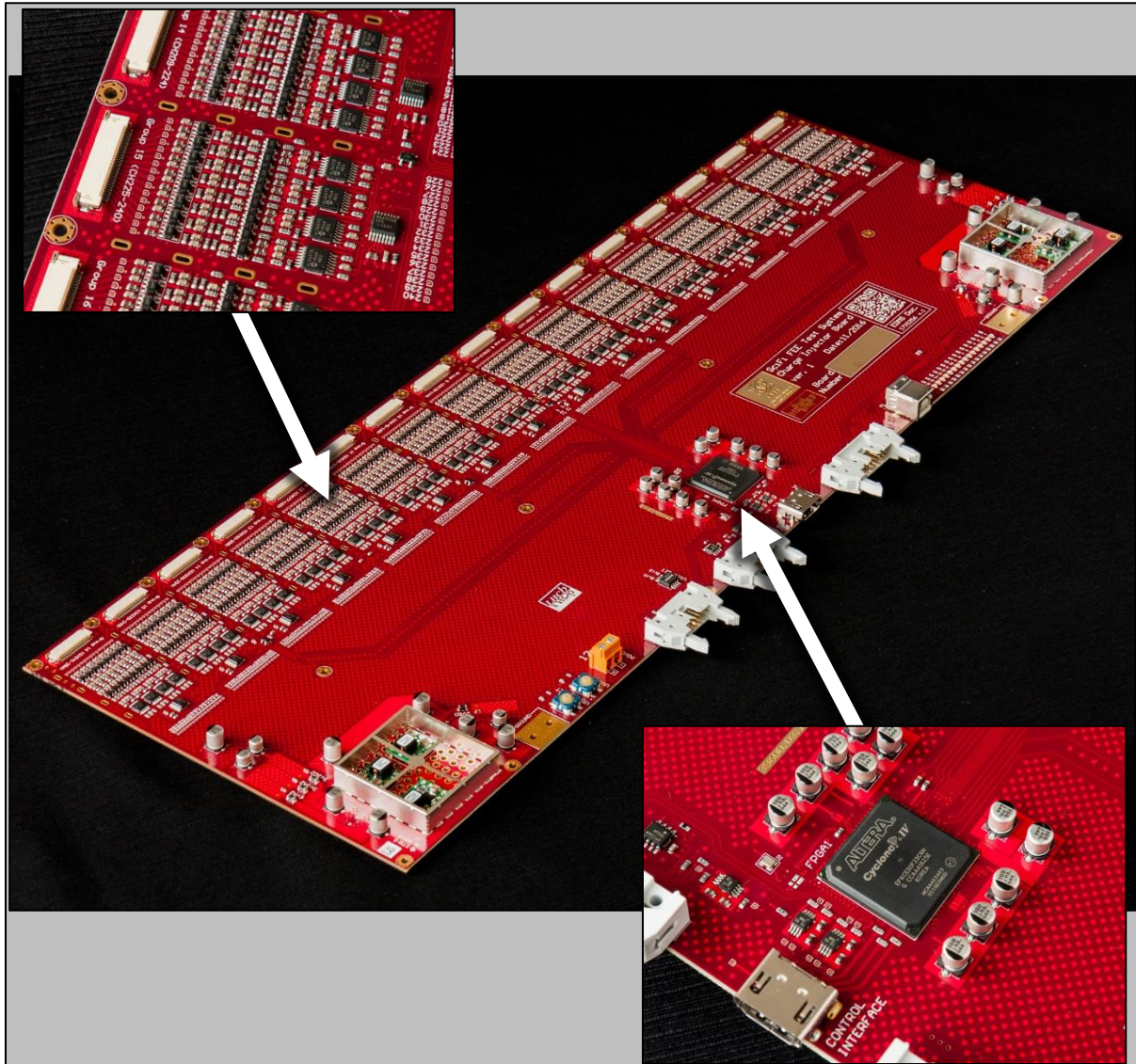



Figure 5: Photo of the Control Module



Figure 6: Photo of the fully assembled Test System in operation at LHCb/CERN

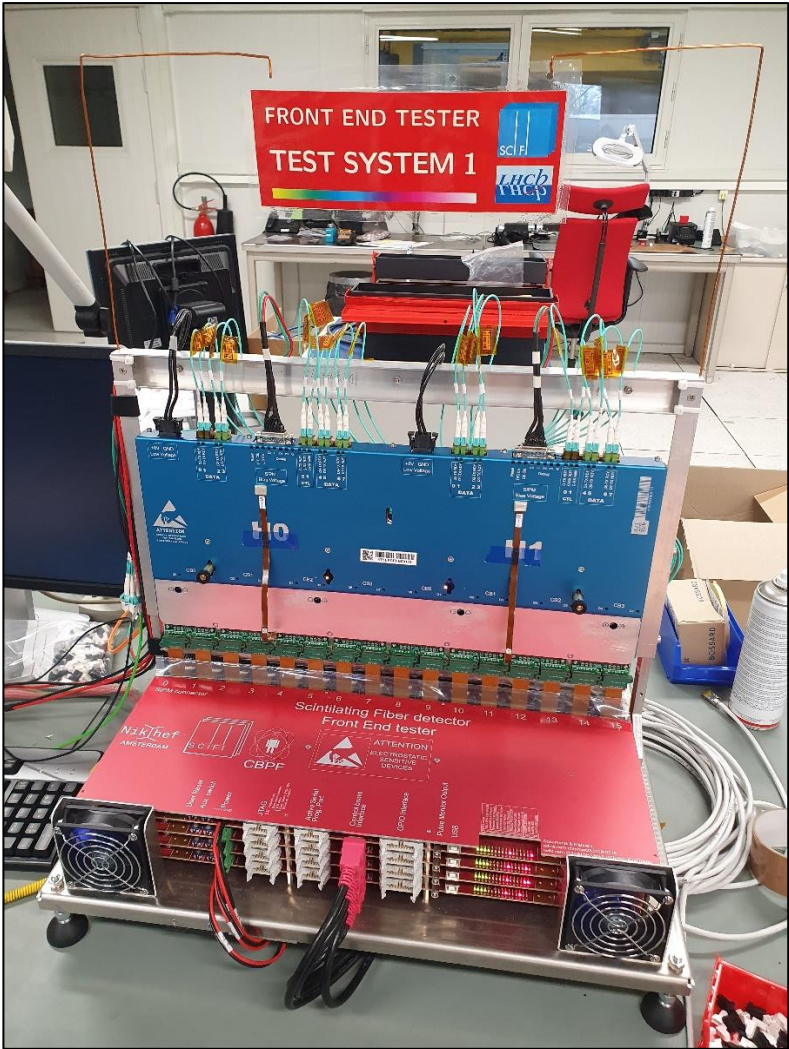

Figure 7: Output Charge calibration curves for multiple pulse width settings.

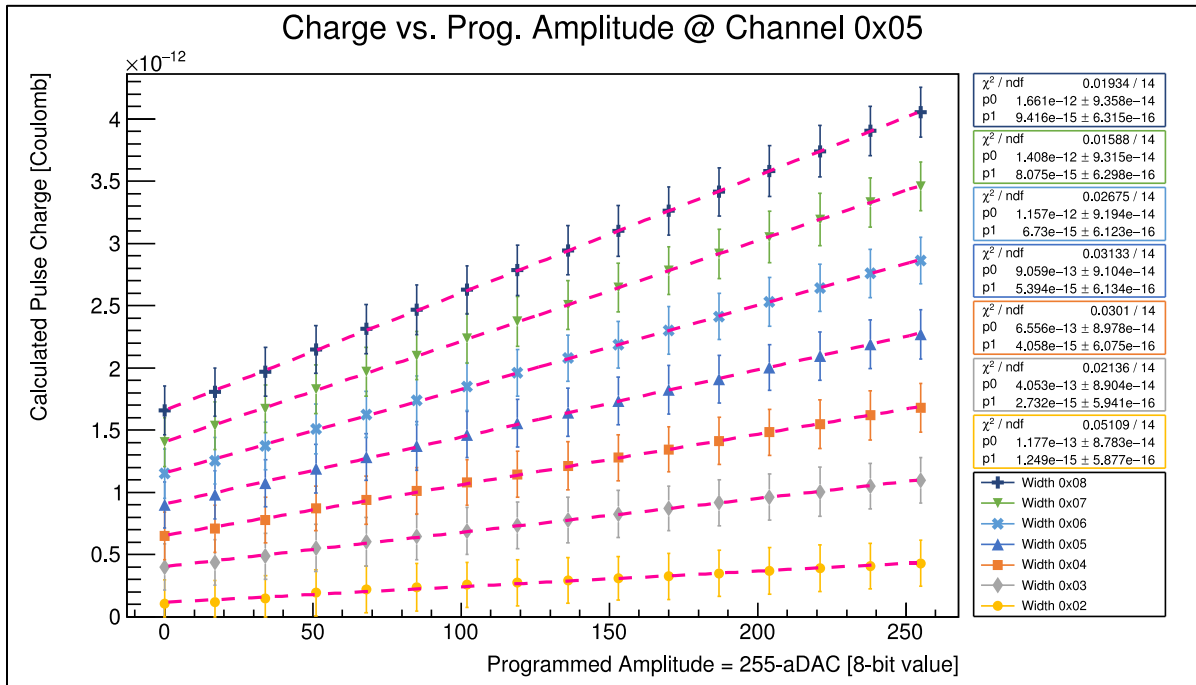

Figure 8: Output pulse timing distribution for multiple pulse amplitude settings.

