

Status and plans of the MilliQan experiment

11th workshop of the Long-Lived Particle Community

David Vannerom on behalf of the MilliQan collaboration
June 2, 2022

The search for particles with exotic charge

Long-lived free propagating



$$Q = \pm e$$



$$Q = \pm e$$



$$Q = 0$$

Confined



$$Q = \pm 2e/3$$



$$Q = \pm e/3$$

The search for particles with exotic charge

Long-lived free propagating



$$Q = \pm e$$



$$Q = \pm e$$



$$Q = 0$$

?



$$Q = \pm \epsilon \times e$$

In particular: $\epsilon \sim 1e-03$

Confined



$$Q = \pm 2e/3$$



$$Q = \pm e/3$$

Low charge particles: a generic model

Many BSM models predict the existence of a simple hidden sector as:

1. A new $U'(1)$
2. A new fermion field ψ charged under $U'(1)$

Through kinetic mixing of the $U'(1)$ with the SM Hypercharge $U(1)$:

ψ acquires an effective, arbitrary charge with respect to the SM photon/Z

Effectively: “**Drell-Yan production of low charge particles**”

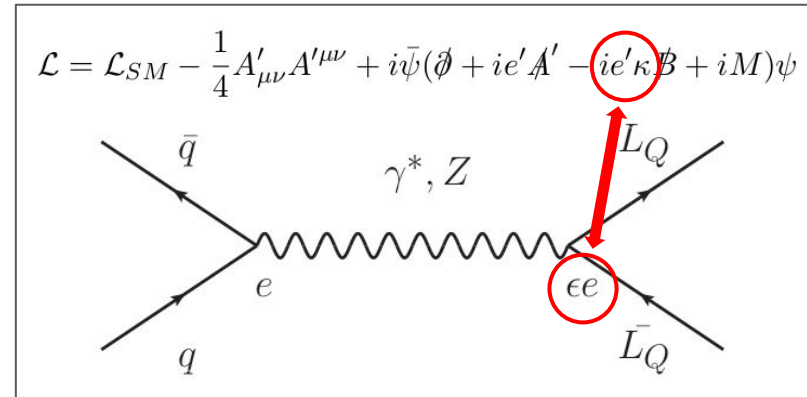

Proof of concept: the MilliQan demonstrator

Large scintillation volume to catch low ionization signals:

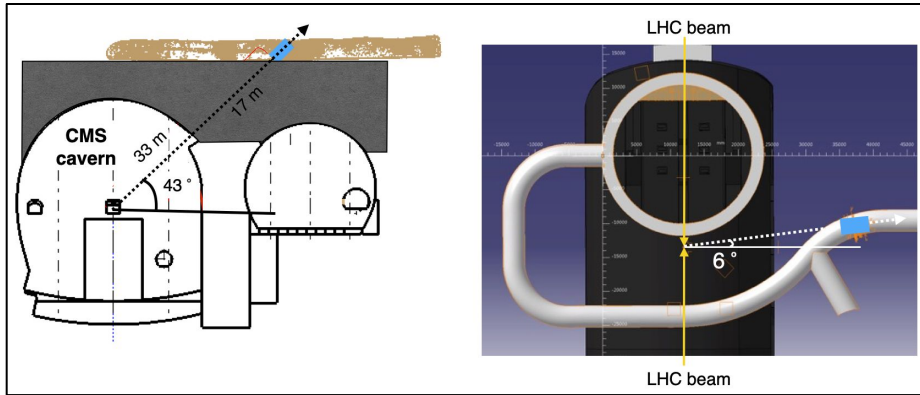

10.1103/PhysRevD.102.032002

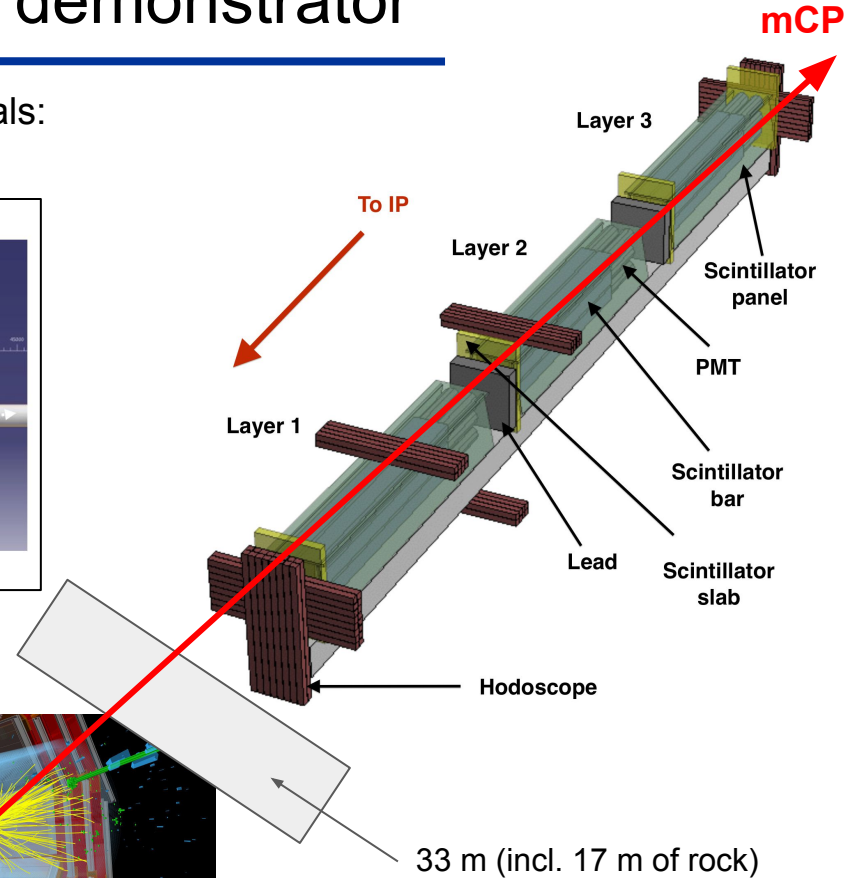

CMS

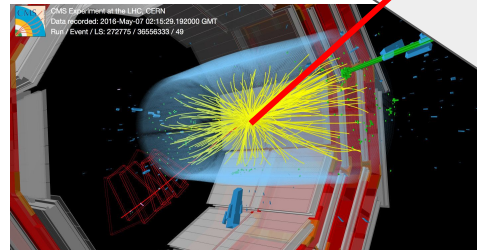

CMS Experiment @ LHC, CERN
Data recorded: 2016-May-07 02:15:29.192000 GMT
Puff / Event / LS: 272775 / 36568333 / 49

Results from LHC Run-2 (2018)

The demonstrator already hit the edge of the excluded region!

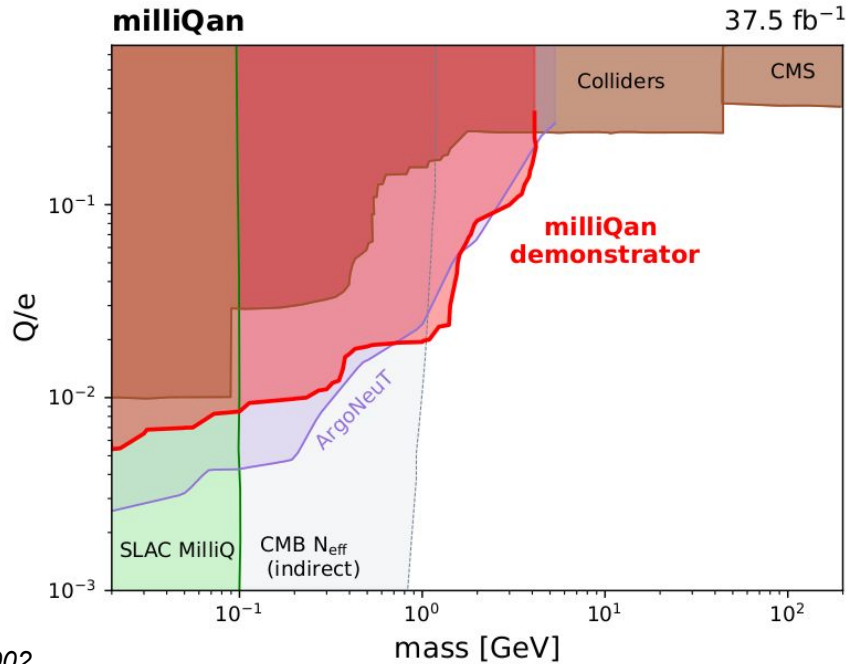

10.1103/PhysRevD.102.032002

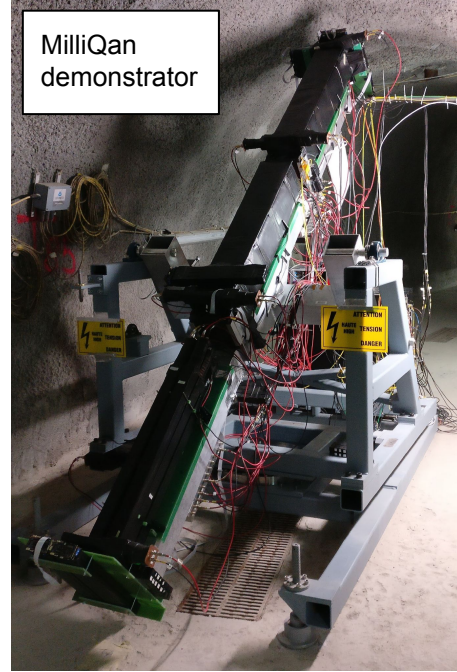

MilliQan gallery

Up-scaling: the Run-3 MilliQan detectors

We are currently testing and assembling two distinct detectors at CERN:

A larger and improved “bar” detector

10.1103/PhysRevD.104.032002

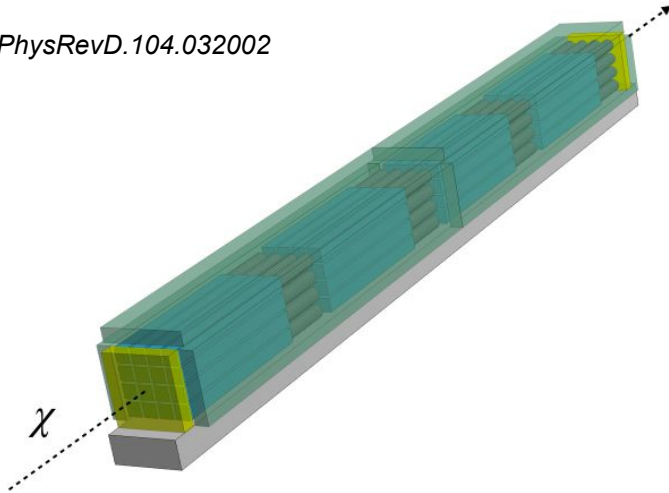

4 x 4 x 4 = 64 60 cm scintillator bars,
each coupled to a pre-amplifying PMT

Not to scale!

A **complementary** “slab” detector

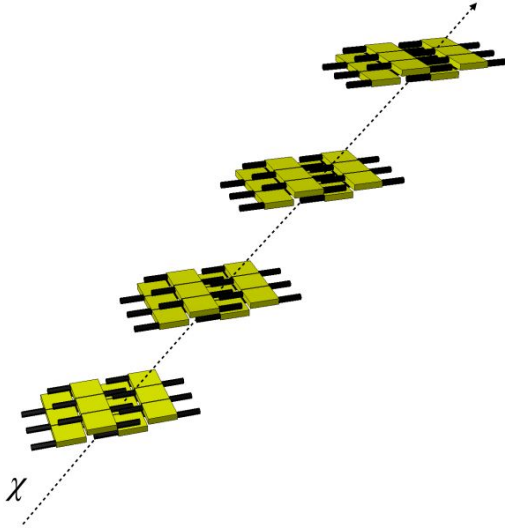

4 x 3 x 4 = 48 scintillator slabs, each
coupled to 4 pre-amplifying PMTs

Up-scaling: the Run-3 MilliQan detectors

We are currently testing and assembling two distinct detectors at CERN:

Bar detector:

- Lower geometrical acceptance (400 cm²)
- Larger seen length per scintillator unit (cm long bars)

⇒ Targets lowest ionizing mCP

(6)

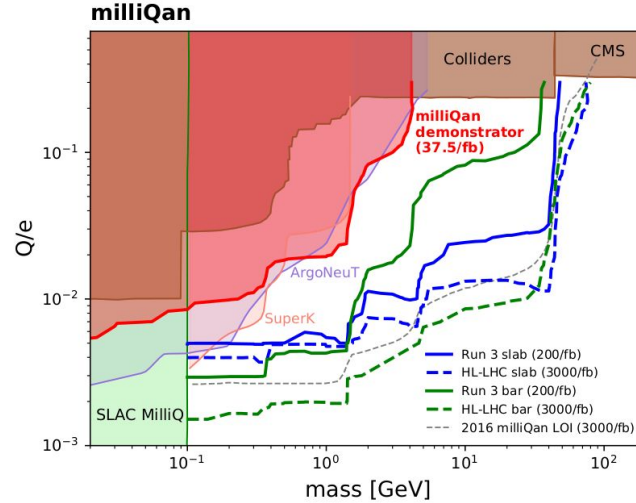
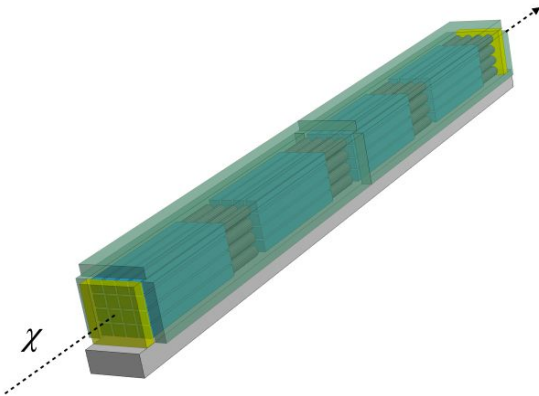

Slab detector:

- Larger geometrical acceptance (28,800 cm²)
- Smaller seen length per scintillator unit (cm deep slabs)

⇒ Targets highest ionizing mCP

(5)

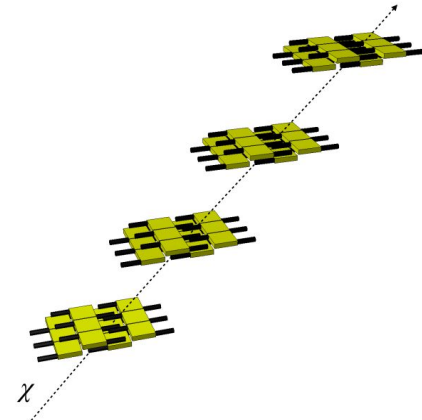

The MilliQan bar detector

Scintillator bars are connected to their PMT and made light-tight:



UCSB PMT mounting setup

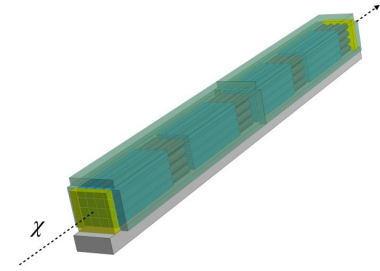

The MilliQan bar detector

Bars are grouped in modules and supermodules and assembled in a metal cage:

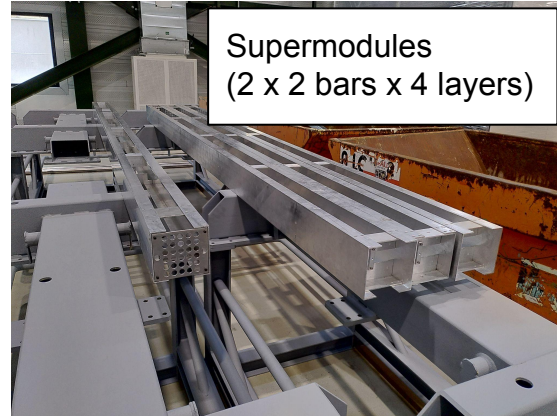
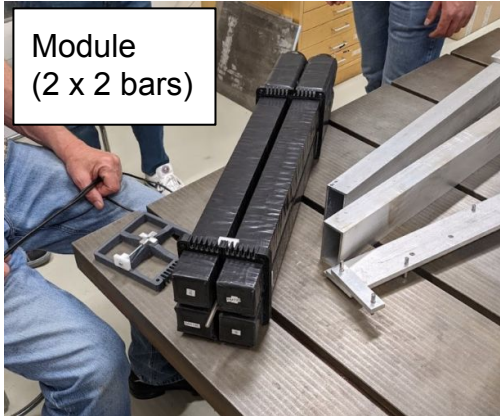
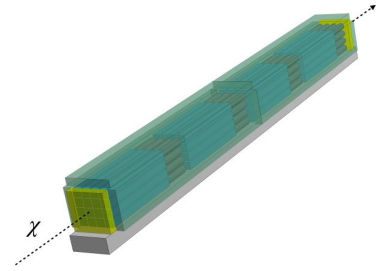

CERN/CMS experimental areas

The MilliQan bar detector

The DAQ for the bar detector is set up in the gallery, waiting for the detector itself:



MilliQan gallery

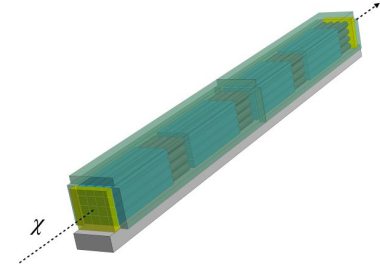

The MilliQan bar detector

Status:

1. All bars have arrived to CERN, mounted and tested
2. The mechanical structure is ready

Next steps:

3. Check again for light-tightness and potential travel damages
4. Assemble bars in the supermodules and into the cage
5. Bring the detector into the gallery
6. Test the DAQ, start running

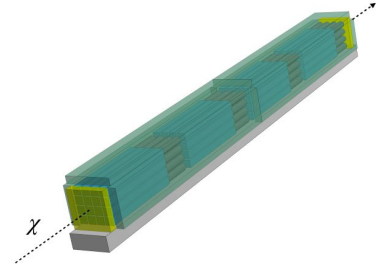

The MilliQan slab detector

PMTs are mounted onto the scintillator slabs and made light-tight:

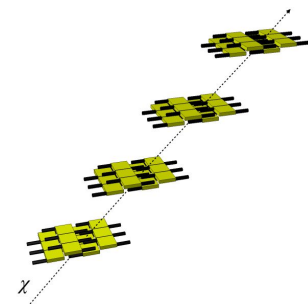

MilliQan lab at CERN LHC P5



The MilliQan slab detector

Slabs will be assembled into the following structure (soon to be machined):

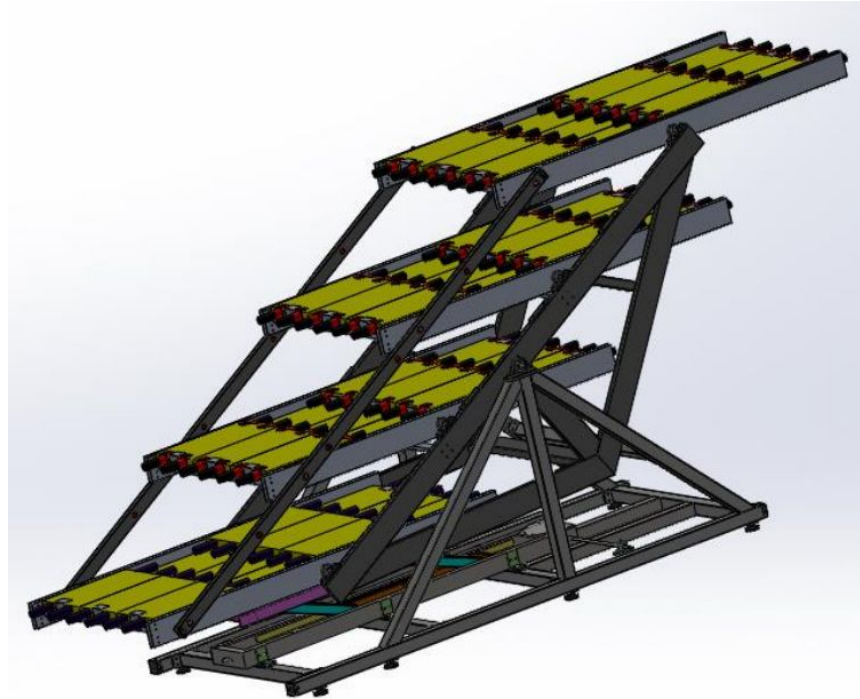

M. Kamra (Lebanese University) and R. Loos (CERN) for MilliQan

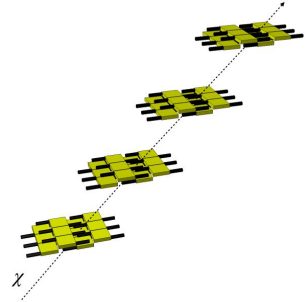

The MilliQan slab detector

Status:

1. Slabs and PMTs have all arrived at CERN
2. All PMT's have been tested individually

Next steps:

3. Mount the PMTs onto the slabs
4. Test the slabs
5. Assemble the slabs into the mechanical structure
6. Lower the detector into the gallery
7. Test the DAQ, start running

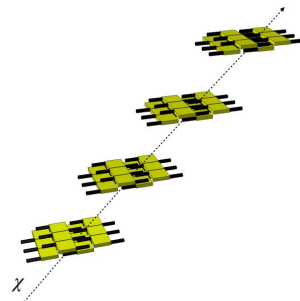

Timeline

Construction is well on its way!

1. All the pieces are at CERN, it's just a matter of time (and effort)
2. We need a couple of months to finish assembly and commissioning.
3. We expect to be able to take data around the end of Summer.
4. The MilliQan Run-3 will significantly tackle yet unexplored regions in the search for millicharge particles

STAY TUNED !

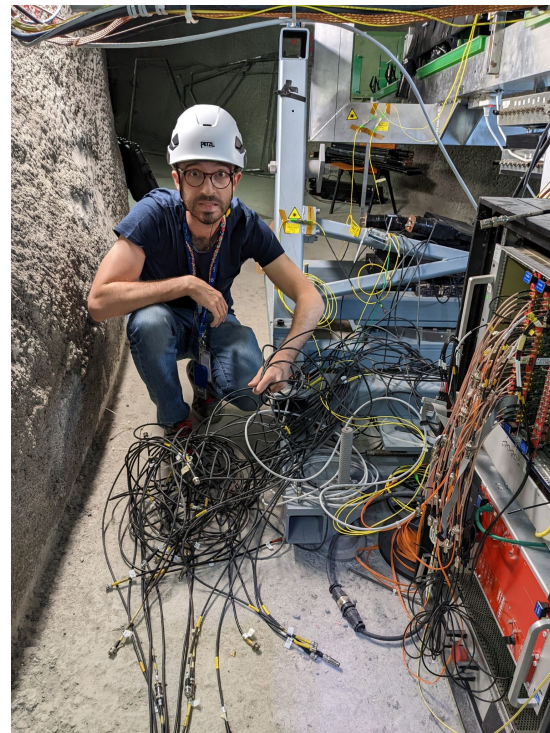

Me struggling with the decabling of the demonstrator...

Backup

The MilliQan collaboration



C. Hill, B. Francis,
M. Carrigan,
A. Lesauvage, L.
Lavezzo, B. Manley



D. Stuart, C. Campagnari,
M. Citron, S. Alcott, K.
Larina, R. Schmitz, K.
Downham, H. Mei, J.
Crowley



A. Haas, M.
Ghimire, Z. Bhatti



D. Miller, S.
Seddon-Stettler



Yu-Dai Tsai



S. Lowette,
D. Vannerom

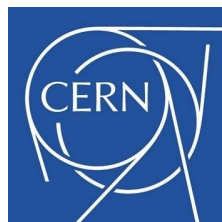

A. Ball, A. De Roeck,
M. Gastal, R. Loos,
H. Shakeshaft



M. Ezzeldine,
H. Zaraket,
M. Kamra



F. Golf, I. Reed



University of
BRISTOL

J. Brooke,
J. Goldstein