



Efficient Energy Management for Particle Accelerators

virtual ARIES Review Meeting, July 15 / 2022

Mike Seidel for WP4, EPFL/PSI

PSI, CERN, CEA/Saclay, Univ.Uppsala, GSI, ESS

Context – Climate Change and Energy Problem



As a science community we should aim at developing solutions and not to be a part of the problem with our research infrastructures.

- increasing energy efficiency
- energy management, adapt to use future fluctuating energy supply

ARIES WP4 addresses 5 topics with networking and individual R&D projects:

- 1) Networking (Sustainable Research Infrastructures Workshop, PSI '19)
- 2) efficient klystron (RF source as part of accelerator power conversion)
- 3) efficient moderator of a neutron source (conversion to neutron flux)
- 4) high Q superconducting cavities (low losses @2K)
- 5) pulsed magnets (low power beam transport)

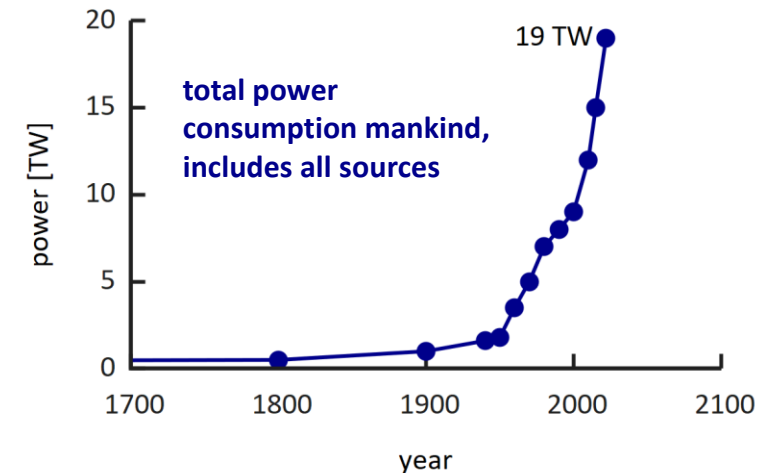

Accelerator driven Research Infrastructures (RI)

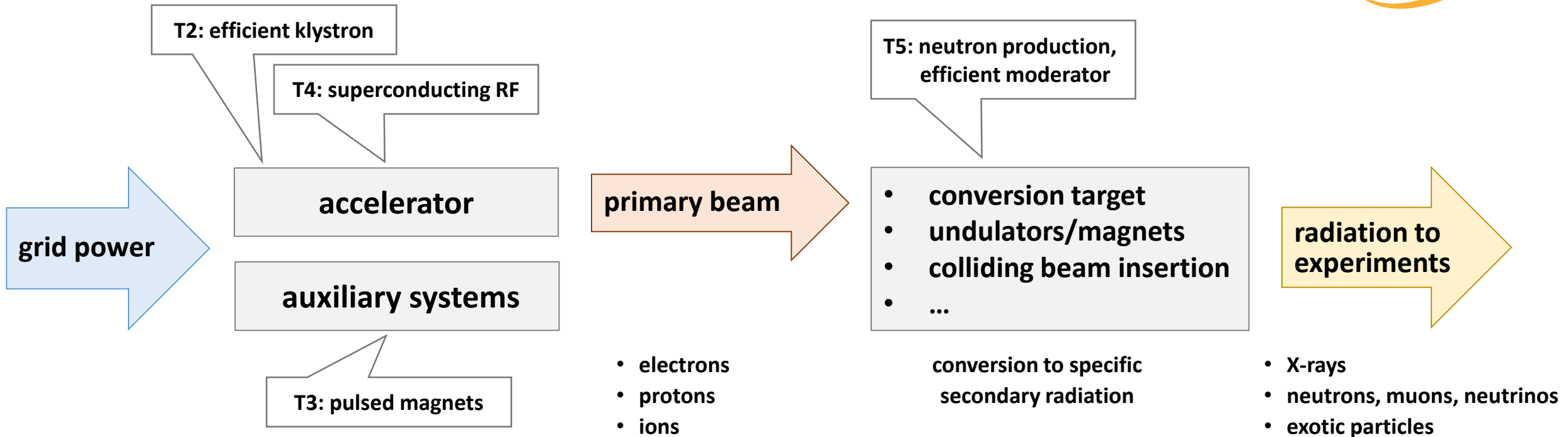

high level goal:

Science output per grid power, per operating/investment cost.

Task2: Efficient Klystron Deliverable

core team: P. Hamel, S. Arsenyev, C. Marchand, J. Plouin, CEA Paris-Saclay

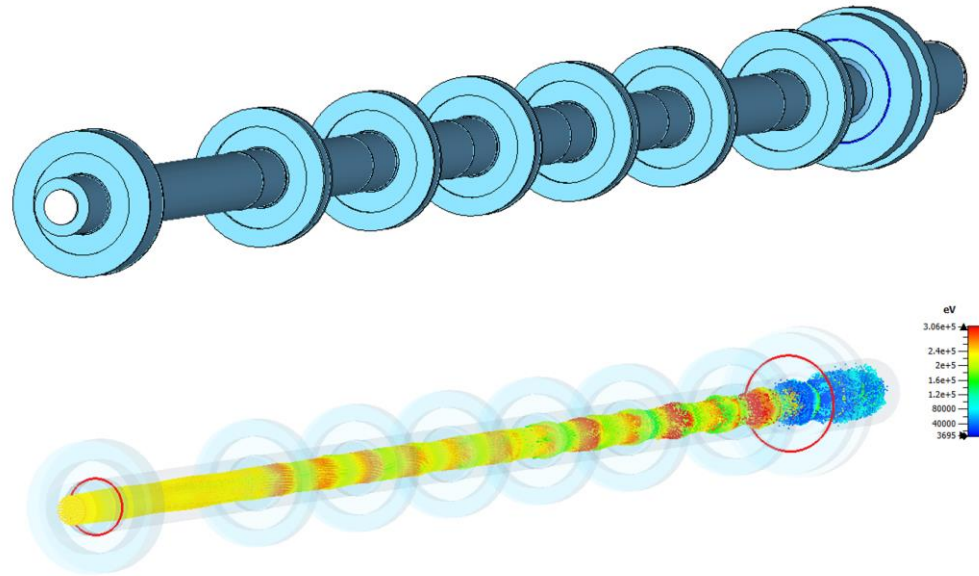

Frequency	11.994 GHz
Perveance	$1.02 \times 10^{-6} A/V^{3/2}$
Cathode voltage	240 kV
Beam current	120 A
Focusing B-field	0.39 T
Output RF power	18.85 MW
RF efficiency	65.5%
3 dB bandwidth	96 MHz
Surface E-field	< 100 MV/m
Klystron interaction length (between gun and collector)	300 mm

Table 9: Key parameters of the designed klystron.

Outcome of study:

- optimized design for 12GHz klystron → could be part of a compact light source
- interaction line for optimized bunching, double gap output cavity for maximized power coupling
- design respects surface field limit of 100MV/m
- efficiency: 65.5% with realistic simulations and boundary conditions

Task 3: Efficient Neutron Production, Lead PSI + ESS

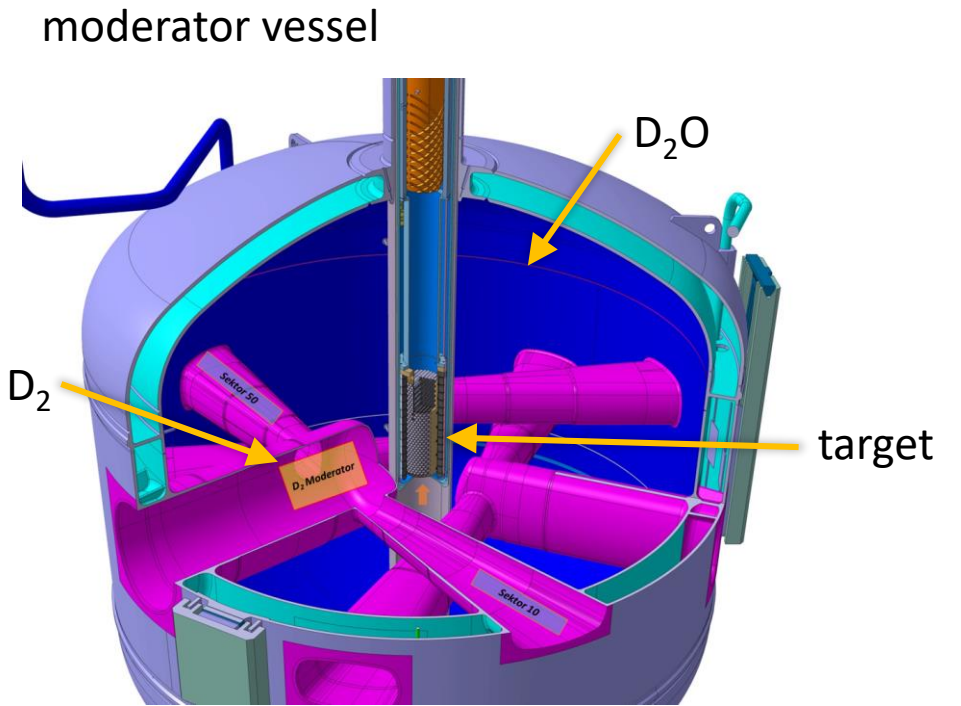
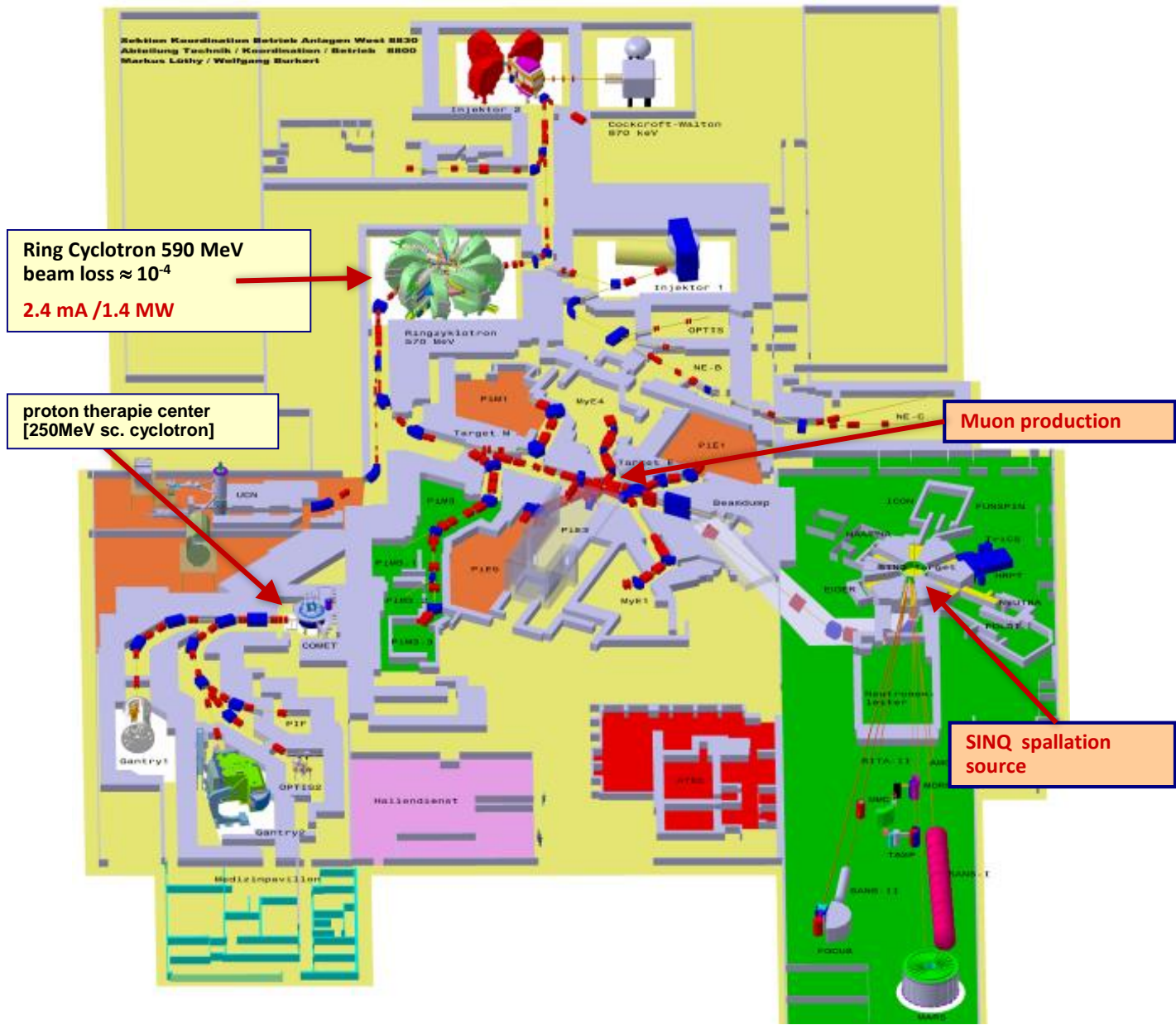

- 20 l of liquid D₂
- T = 25 K, P = 1.5 bars
- Heat load ≈ 1 kW

goal: study cold moderation in D₂ & geometry, to improve the rate of neutrons scattered into neutron guide

- neutron transport simulations
- fluid dynamics of D₂ under power deposition by p-beam

concept: re-entrant hole, emptied during operation, to maximize neutron flux

Efficient Moderator

core team: S.Jollet, Y. Charles (fluid dynamics), R.M. Bergmann, D.Kiselev, M.Wohlmuther (neutronics)



neutron yield w/o re-entrant cavity in moderator
predicted gain: 1.25 to 1.31 at medium wavelength

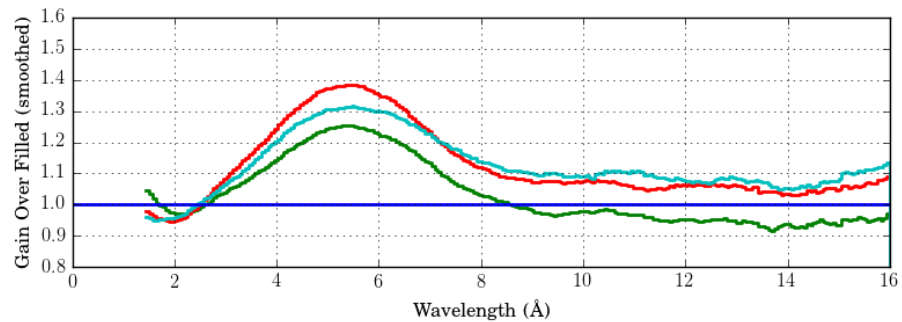
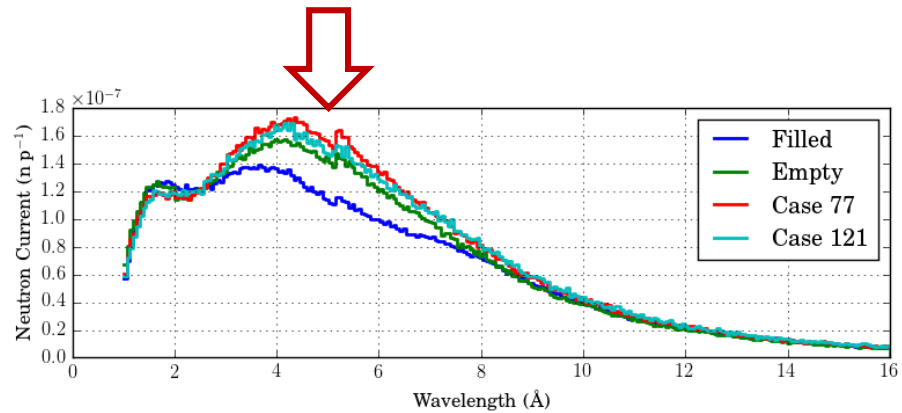

neutrons: $\lambda = h/p$, $2\text{Å} = 2 \times 10^{-10}\text{m} = 25\text{meV}$

figure: pairs of top and side view
left: current geometry (re-entrant hole in red)
center: result of parametric scan optimization
right: geometry by “genetic optimization”

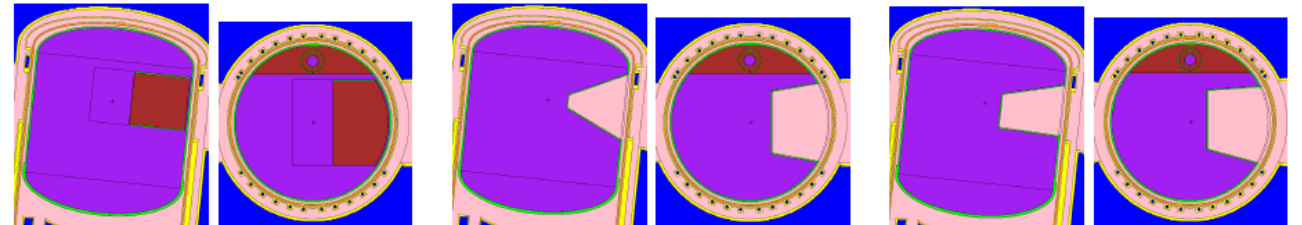

Outcome of study:

- understanding of fluid dynamics and neutron yield of present geometry
- proposal of improved geometry

Task 4: High Efficiency SRF Beam acceleration

lead: CERN, A. Ivanov, F. Gerigk, S. Papadopoulos, S. Ramberger, A. Macpherson

to further improve the quality factor of s.c. resonators, systematic limitations are studied in detail:

- reduce external magnetic field by shielding to avoid trapping of flux
- study the mechanism of flux trapping with the aim to avoid it

Outcome of study:

- design & verification of magnetic shielding for a test setup
- developed instrument “**flux lens**” for quick and reproducible measurements of the flux expulsion efficiency of Niobium sheet material

Simulation of flux expulsion on multicell bulk Nb cavity

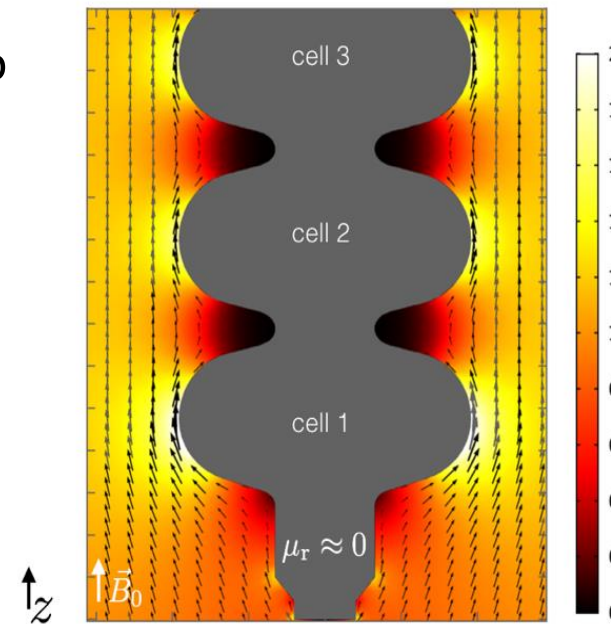

Experimental set-up to measure flux expulsion during cool-down.

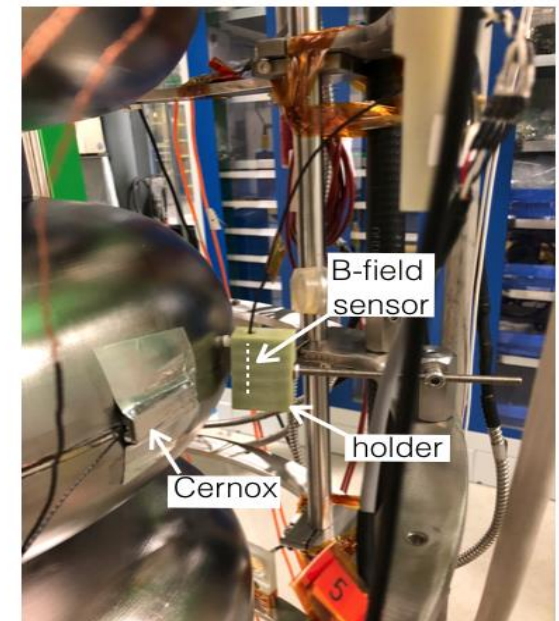

Task 5: Pulsed Magnets for beam Transfer Channels

in lead: GSI, S. Heberer, P. Gehrke, P.Spiller et al



- low average power; high field; compact; energy recovery in capacitive storage
- complexity added by pulsing circuit; field precision potentially challenging

	Prototype Quadrupole
Gradient	80 T/m
Length	0.65 m
Pulse length	90 ms (beam 1 ms)
Peak current	400 kA
Peak voltage	17 kV
Energy @17 kV	65 kJ
Inductivity	535 nH
Capacitor	450 mF
Forces	200 kN

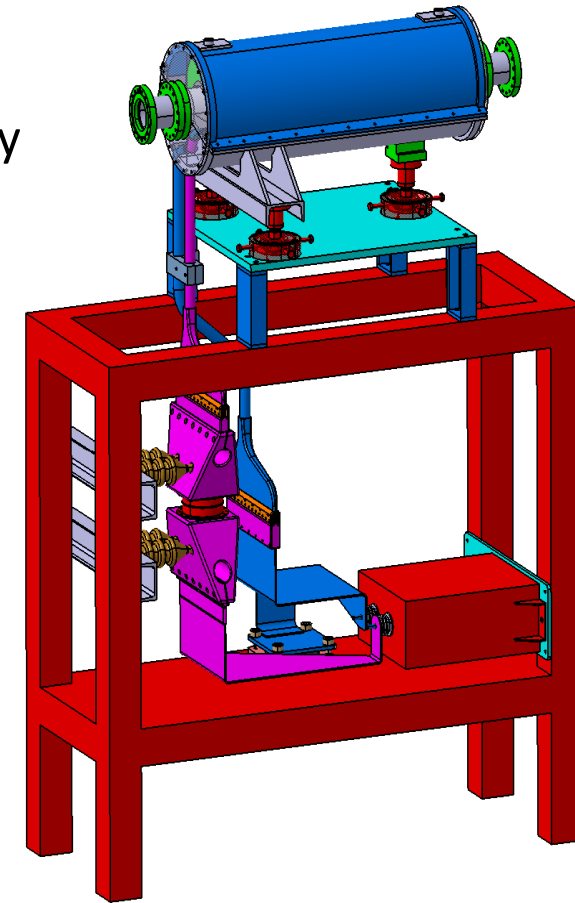

Engineering model of the prototype quadrupole magnet incl. support

Pulsed Magnets for beam Transfer Channels

in lead: GSI, S. Heberer, P. Gehrke, P.Spiller et al



Assembly of HV-Diode, damping resistor, main switch and trigger unit, safety discharge circuit



Quadrupole

Pulsed power unit

Main Switch



Safety discharge circuit

Diode with clamping unit

Capacitor

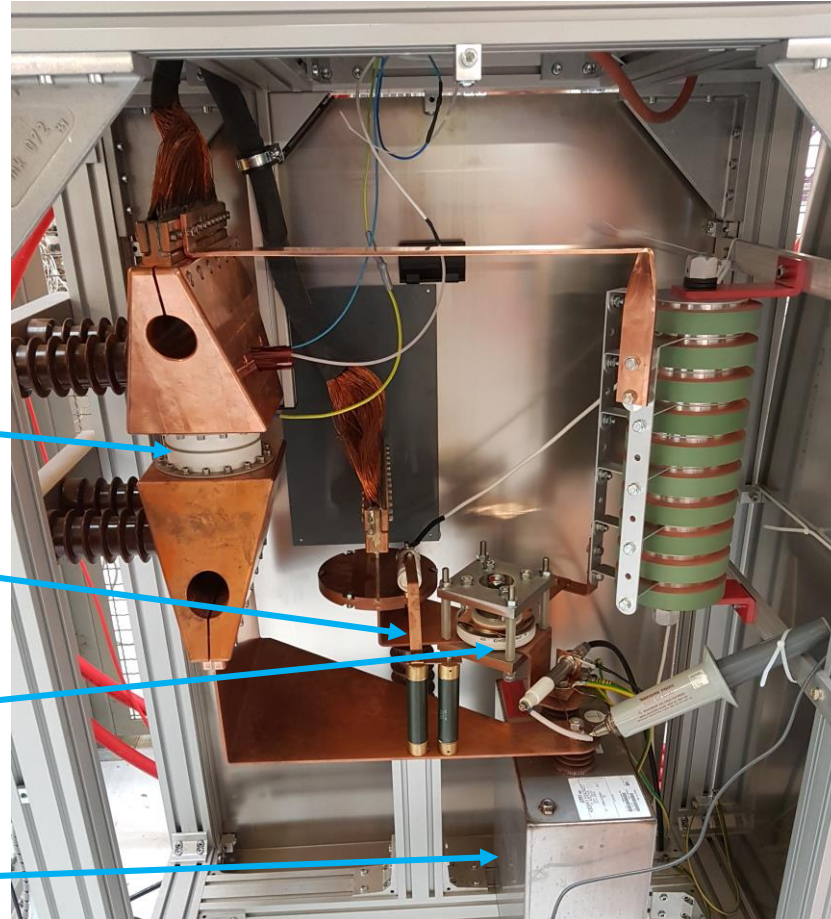

Outcome of study:

- simulation and optimization of pulse forming network to minimize ohmic losses and maximize energy recovery for next pulse
- 28% energy recovery achieved, energy efficiency improved by 80%
- prototype circuit build and tested

Summary

Efficient Energy Management for Particle Accelerators

Task 4.1: General [M.Seidel, PSI/EPFL]

Workshop on sustainable research infrastructures November 2019 at PSI; **very broad program, good visibility**

Task 4.2: Efficient RF Generation [C.Marchand, CEA Saclay]

Design of a 12 GHz high efficiency kladistron, ARIES co-financed postdoc; **65% efficiency obtained**

Task 4.3: Efficient Neutron Production [M.Wohlmuther, S.Jollet, PSI]

Monte Carlo simulations on an efficient neutron source - target and moderator geometry; **new type of 2-phase simulations established with concept proposals for SINQ, 25% gain feasible**

Task 4.4: High Efficiency SRF Beam acceleration [F.Gerigk, CERN]

experimental and theoretical work on flux trapping and magnetic shielding; ARIES co-financed Post-Doc; **understanding of magnetic shielding & Nb sample test device**

Task 4.5: Pulsed Magnets with Energy Recovery [P.Spiller, GSI]

a prototype pulsed power supply has been set up; with **circuit recovering 28% of energy from pulse to pulse**

→ 5 milestones (topical workshops) were achieved and 4 deliverables (reports of tasks 2-5) produced.



Spare Slides

Task 1 (Networking): Workshop on Sustainable Infrastructures

Paul Scherrer Institut, November 28-29, 2019

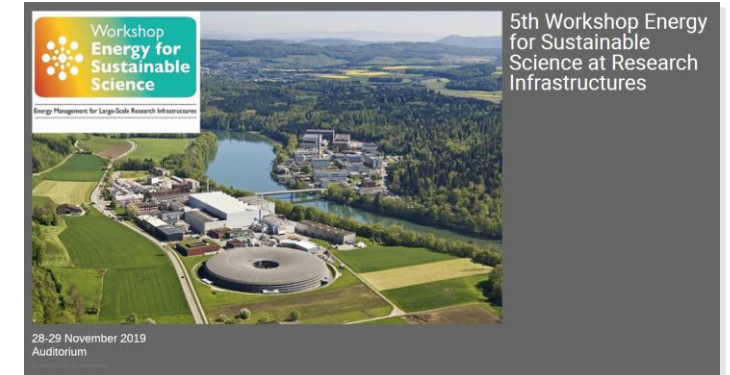

Overview CERN/ERF/ESS Workshop

Agenda

- Booklet
- Timetable

Contribution List

Registration

Participant List

Accommodation

Workshop Dinner

PSI Facility Tour

Visa

How to get to PSI

Scarcity of resources, along with rising energy costs and climate change are ever growing concerns that need to be considered for the next generation of large-scale research infrastructures. Indeed, the much increased performance of proposed new facilities often comes together with anticipated increased power consumption. Mid- and long-term strategies have to be devised for sustainable developments at research infrastructures, including the aim for reliable, affordable and carbon-neutral energy supplies.

This workshop will bring together international sustainability experts, stakeholders and representatives from research facilities and future research infrastructure projects all over the world in order to identify the challenges, best practices and policies to develop and implement sustainable solutions at research infrastructures. This includes the increase of energy efficiencies, energy system optimizations, storage and savings, implementation and management issues as well as the review of challenges represented by potential future technological solutions and the tools for effective collaboration.

The **Paul Scherrer Institut**, in collaboration with **CERN** (The European Organization for Nuclear Research), **ERF** (The European Association of National Research Facilities), **ESS** (The European Spallation Source), and **ARIES** (The Accelerator Research and Innovation for European Science and Society), will host on 28-29 November 2019, the fifth Workshop on Energy for Sustainable Science at Research Infrastructures Facilities.

This workshop is the fifth event in the series "Energy for Sustainable Science at Research Infrastructures" that is organized by ERF, CERN and ESS holding biennial workshops at various places. The first workshop was held at **ESS, Sweden** on 13-14 October 2011, the second workshop at **CERN, Switzerland** on 23-25 October 2013, the third workshop at **DESY, Germany** on 29-30 October 2015, and the fourth one at **ELI-NR, Romania** on 23-24 November 2017. PSI will host the fifth workshop in this series in cooperation with ARIES.

Organizing Committee
Carlo Bocchetta, ESS
Frederick Bordry, CERN
Florian Gliksohn, ERF
Joachim Grillenberger, PSI
Frank Lehner, DESY
Thomas Schmidt, PSI
Carlo Rizzuto, ELI
Mike Seidel, chair, PSI

<https://indico.psi.ch/event/6754/>

88 registered participants

spare slide: Topics @ SSRI Workshop 2019

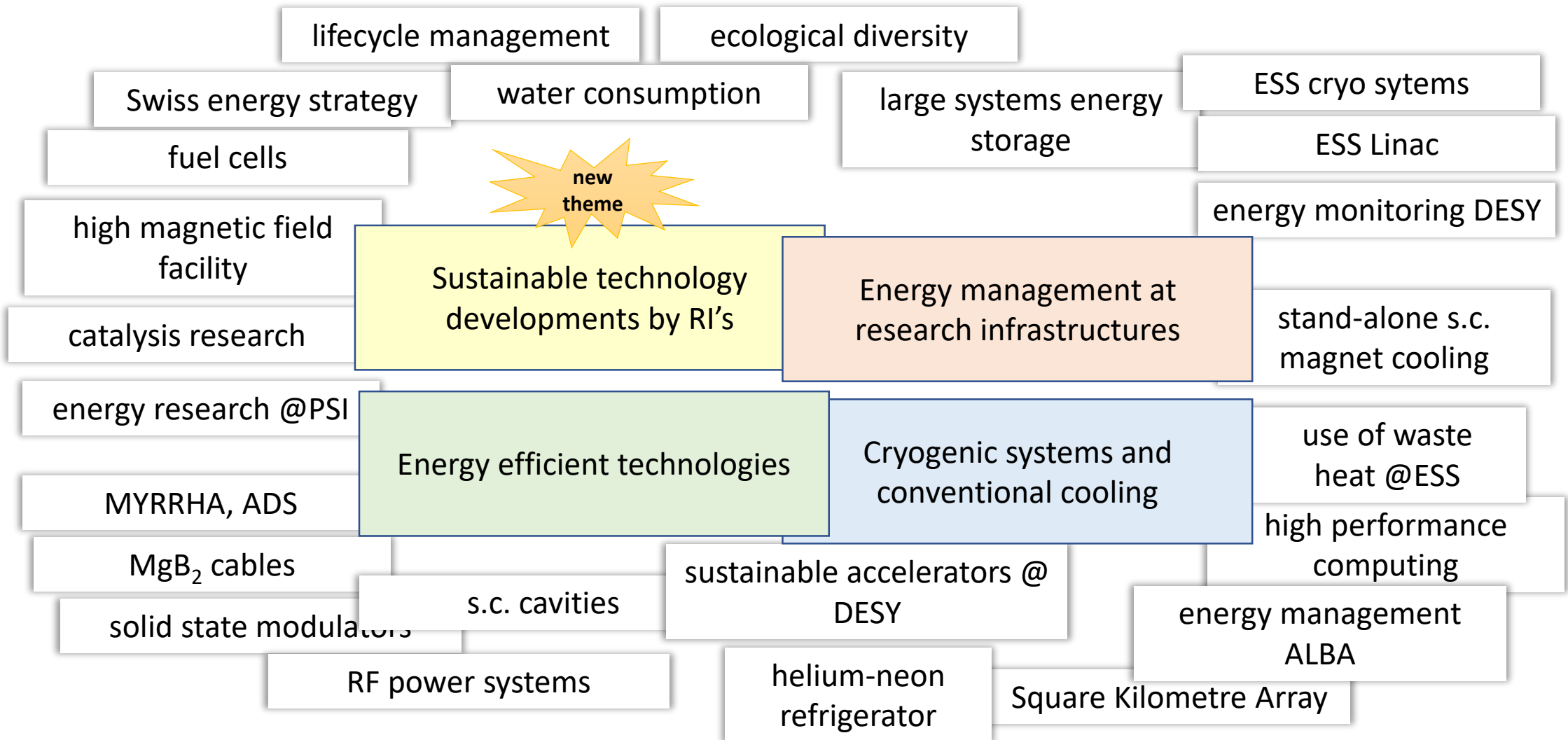

Thank you !

Overview

- Scientific Programme
- Call for Abstracts
- Proceedings
- Timetable
- Contribution List
- Registration
- Participant List
- WLAN at PSI
- Committees
- Key Dates
- PSI Area Plan
- Direction to PSI
- Accommodation
- Workshop Dinner
- ARIES

Contact

- ✉ ENS2019@psi.ch
- ☎ +41 56 310 55 83



Since its discovery by James Chadwick in 1932, both fundamental and applied science made an extensive use of the neutron as a probe for physical phenomena, material properties, and imaging. Up to the 1970s, reactor-based neutron sources had been designed to reach high neutron fluxes for research, followed by the development of powerful spallation sources. Nowadays, reactor- and spallation-based neutron sources coexist, the former providing continuous neutron fluxes while the latter delivers intense pulses – with the notable exception of the continuous spallation target **SINQ** at **PSI**, Switzerland. The ongoing plans for construction and upgrades of neutron sources all over the world raise the question of increasing the source efficiency at a time where policymakers orient towards more sustainability and reduced energy consumption.

The Workshop on Efficient Neutron Sources – ENS2019 – will bring together nuclear physicists, chemists, material scientists and mechanical engineers to discuss the efficiency of neutron sources, and determine the most promising perspectives for improvement. With the aim of reaching more efficient reactor and accelerator-based neutron sources, ENS2019 will include sessions dedicated to the following topics:

- Neutron Production
- Moderators & Reflectors
- Neutron Guides
- Instruments & Detectors



Workshop Efficient Neutron Sources

PSI, Sep 2-5, 2019
co-organised by ESS & PSI
63 participants (even Argentina)
rich documentation on website

John Carpenter
engineered first spallation
neutron source (Argonne, 1980)



Magnetic flux lens: a novel stand-alone instrument to measure efficiency of flux expulsion



Concept

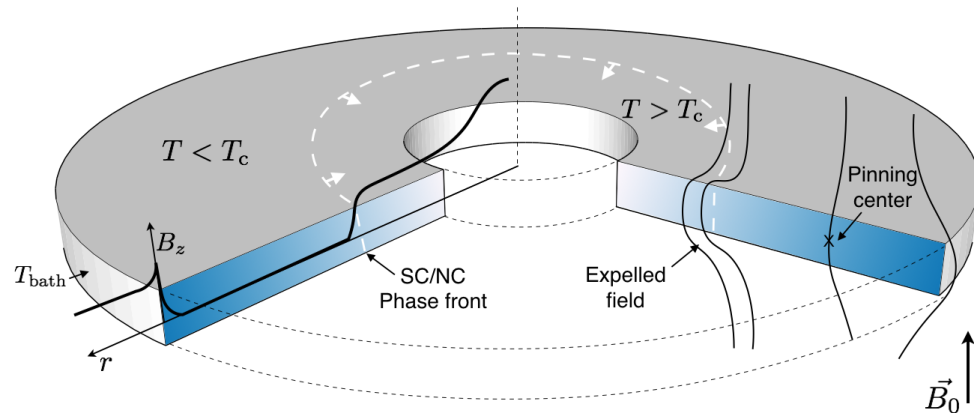

Nb sample is shaped like a disc and symmetrically cooled towards the center → expelled flux will be “collected” at the aperture

Acts as lens → the stronger the field is enhanced in the center the better the material quality (higher flux expulsion efficiency)

Design

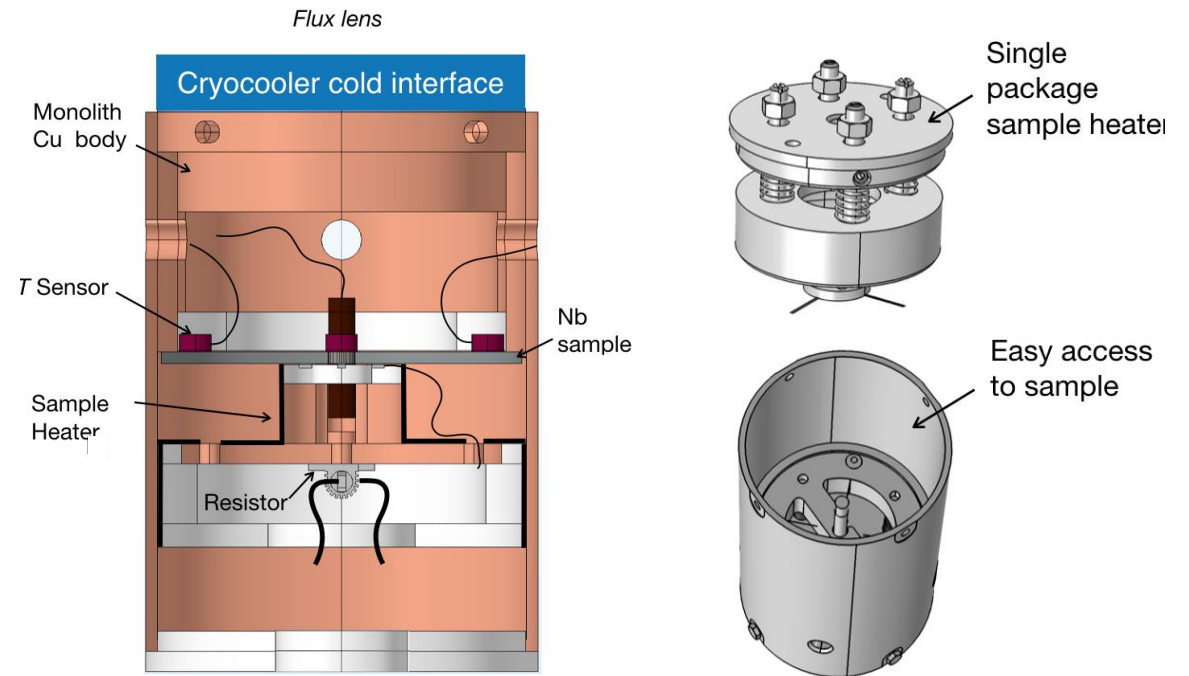

Device allows to test flux expulsion vs T-gradient (gradient at cool down allows depinning of trapped flux)

Flux trapping workshop @ CERN, 8-9 Nov 2018



64 participants from the North America, Asia & Europe.

Supported by ARIES. Milestone: MS18, [report](#)

<https://indico.cern.ch/event/741615/overview>



Workshop "Energy Efficient Beam Transport Technologies"

26 April 2021
ZOOM
Europe/Berlin timezone

Overview

Timetable

Registration

Participant List

Vera Wyderka

v.wyderka@gsi.de

The Energy Efficient Beam Transport Workshop in the scope of the EU-ARIES workpackage "Energy Efficiency of Particle Accelerators", aims to cover several aspects related to this topic.

The goal is to discuss opportunities and concepts for an efficient beam transport, aiming for reduced energy consumption and consequently operation costs.

The workshop comprises suitable technological solutions, e.g. pulsed or superconducting systems, as well as the influence of operation modes.

Specific aspects driven by the view of the facility as a whole, e.g. energy management may be covered as well.

Starts 26 Apr 2021, 09:00
Ends 26 Apr 2021, 17:00
Europe/Berlin

ZOOM
<https://gsi-fair.zoom.us/j/94799749443>
Passcode will be sent after registration.

EU-Aries Workpackage "Energy Efficiency of Particle Accelerators"

<https://www.psi.ch/en/enefficient>

We are kindly asking all presenters to upload a short abstract (0.25-0.5 page) beforehand. We will be combining them into a **Book of Abstracts** for everyone at the end of the workshop.

Thank you.



Anmeldung / Registration

Die Anmeldung für diese Veranstaltung ist offen. / Registration for this event is currently open.

8

Jetzt anmelden / Register now



The call for abstracts is open

You can submit an abstract for reviewing.

Submit new abstract



last virtual Workshop organised by GSI April 26, 2021, Efficient Beam Transport

