



# 12<sup>th</sup> HL-LHC Collaboration Meeting

## Closeout

Uppsala – September 19<sup>th</sup> to 22<sup>nd</sup> 2022

H I G H L U M I N O S I T Y L H C

# 12<sup>th</sup> HL-LHC Collaboration Meeting

## UPPSALA - Sweden

### 19 - 22 September 2022



The 12<sup>th</sup> HL-LHC Collaboration Meeting will take place in Uppsala, Sweden, from 19<sup>th</sup> to 22<sup>nd</sup> September 2022, as an in-person meeting.

Based on the traditional programme with plenary and work package parallel sessions, this meeting will serve as a technical update forum for the 6<sup>th</sup> Cost and Schedule Review, planned at CERN in November 2022, and provides the framework for additional collaborative meetings between the project partners.

This year, the main objectives will be to update all HiLumi collaborators on the results of key HL-LHC prototypes tests, to highlight the progress made in the transition from prototype validation to series production, and to update all collaborators on the latest schedule changes.

**CERN - Organizing Committee**

Oliver Brüning *Project Leader*  
 Markus Zerlauth *Deputy Project Leader*  
 Cécile Noels *Project Office*  
 Irene García Obiero *Project Office*

**Uppsala - Organizing Committee**

Tord Ekefjell *Chairperson*  
 Richard Benner *Head of Physics Department*  
 Maja Olvegård *Head of FREIA Department*  
 Rocío Santiago Kern *Technical Leader (DHF project)*

**For more details and registration**

[cecile.noels@cern.ch](mailto:cecile.noels@cern.ch)  
[www.hilumihc.web.cern.ch](http://www.hilumihc.web.cern.ch)



# Post-Covid Workshop Organization

**Many thanks to Tord for his patience!**

**-> 3 years after the first planning!**

**Many thanks to ALL of YOU for making the trip!**

**Many thanks to Cecile and Irene for all the preparation work and organization!**



# It Felt Great to have again an In-Person Conference!





**Thanks to Uppsala for welcoming us with fabulous weather and facilities!!**

# Thanks to Tord for a spectacular Conference Dinner!



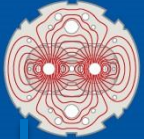

# LHC / HL-LHC Plan

EU funded HiLumi Design Study

Approval of HL-LHC Project

We are here



HL-LHC Operation

HL-LHC

Run 4 - 5...

13.6 - 14 TeV energy

5 to 7.5 x nominal Lumi

integrated luminosity  
3000 fb<sup>-1</sup>  
4000 fb<sup>-1</sup>

OMM.

PHYSICS

Run 1

LS1

splice consolidation  
button collimator  
R2E project

7 TeV

8 TeV

2011

2012

2013

2014

experiment  
beam pipes

75% nominal Lumi

30 fb<sup>-1</sup>

HL-LHC TECHNICAL EQUIPMENT

DESIGN STUDY

HL-LHC

DEFINITION

6 years since project approval  
6 years until end LS3

development to  
Series production is well  
underway!

PV PV Trend (Baseline 5.5.0) EV AC

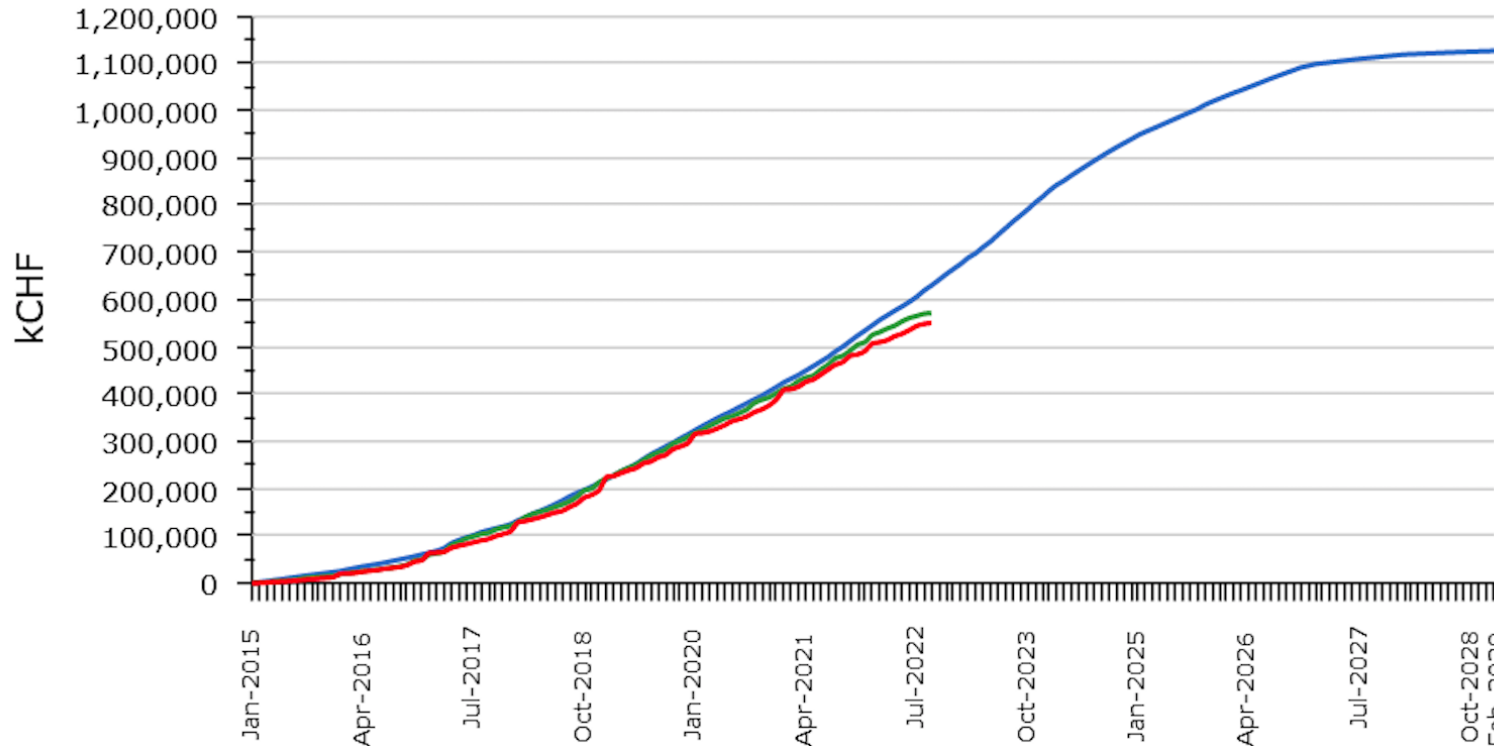

# Main civil engineering work at Point 1 (ATLAS)

## Underground

(Fully completed on 25 Oct'21)

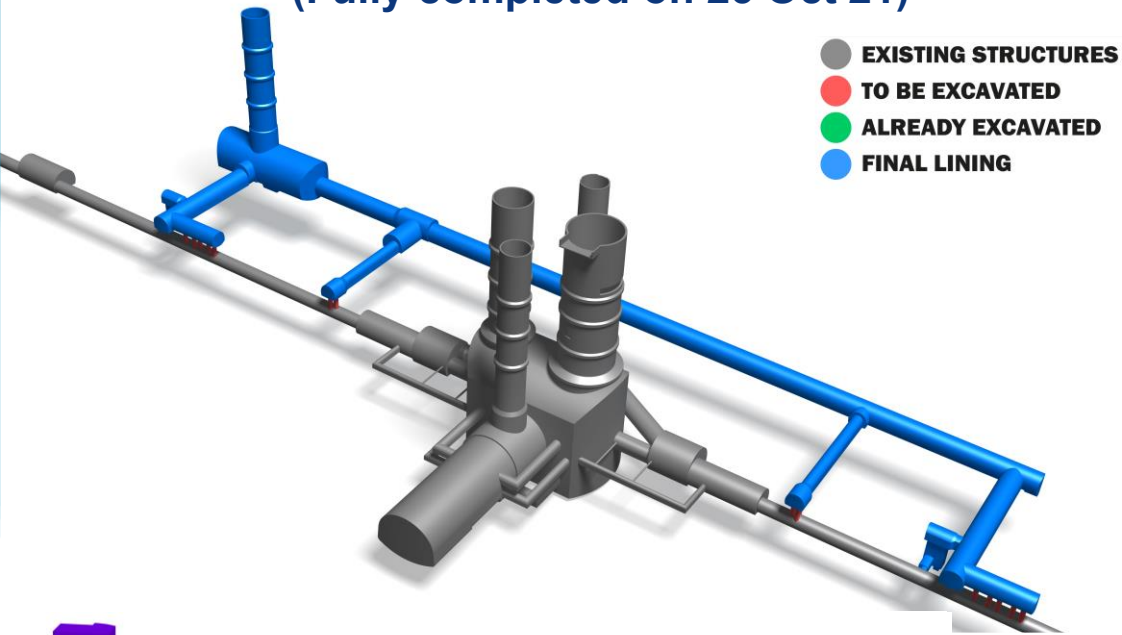

## Surface

STATUS: 2022.09.09

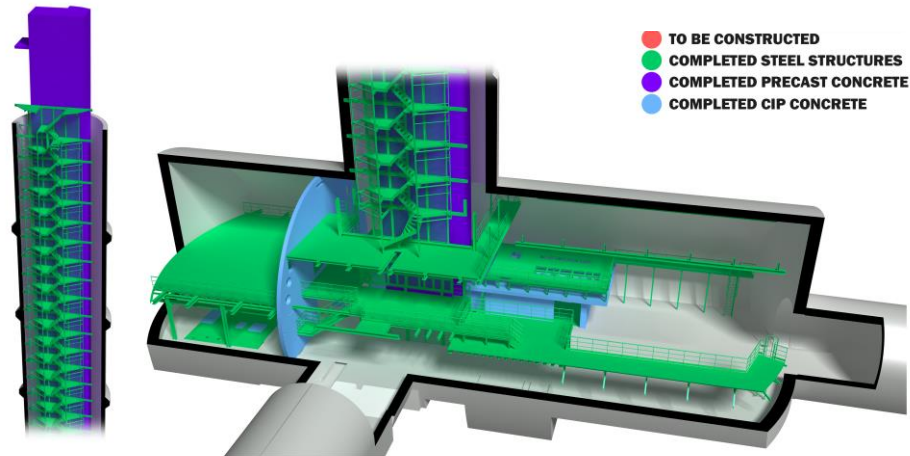
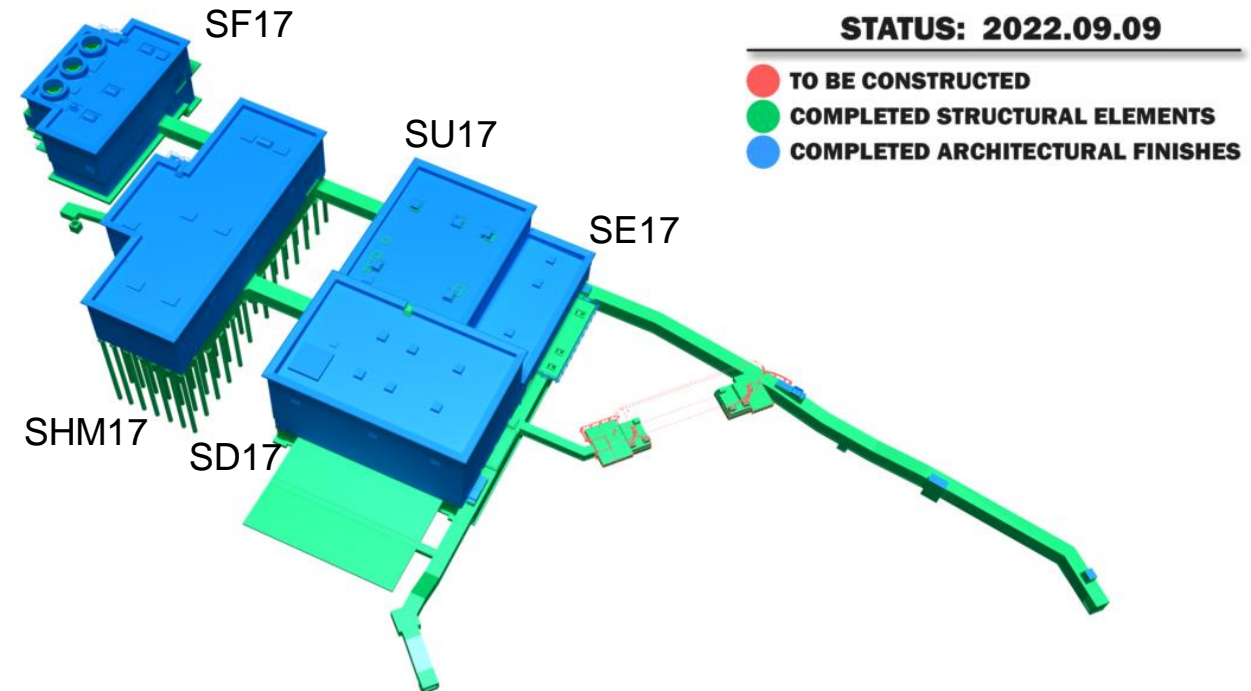

Buildings	Progress [%] / delivery
SF17	100% / delivered
SHM17	100% / delivered
SU17	100% / delivered
SE17	95 % / 26 Sep'22
SD17	95 % / 26 Sep'22
Underground	100% / 26 Sep'22

**Fully completed and delivered by Sep'22 (+ ~1 months w/r to the initial contractual date)**

Pieter Mattelaer and Laurent Tavian

# Main civil engineering work at Point 1 (ATLAS)

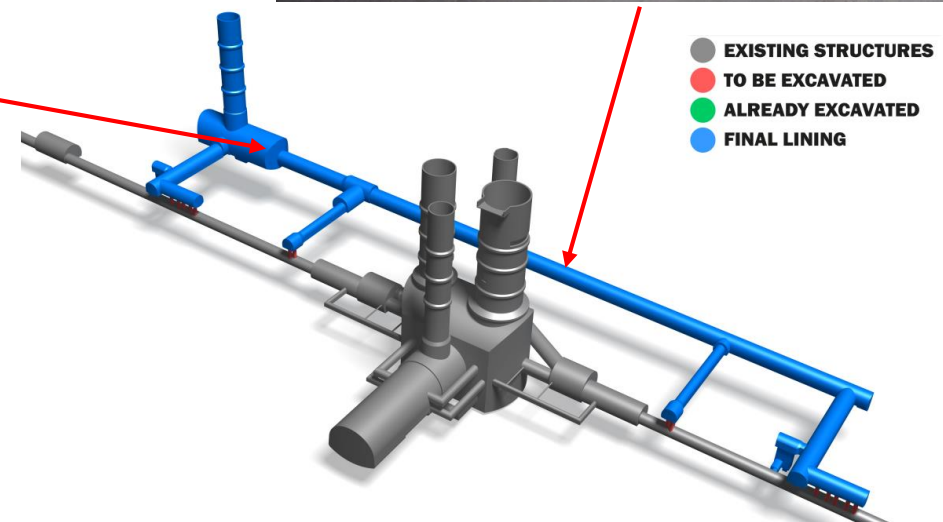



# Main civil engineering work at Point 1 (ATLAS)



Pieter Mattelaer and  
Laurent Tavian

# IT String Preparation Entering Main Stage

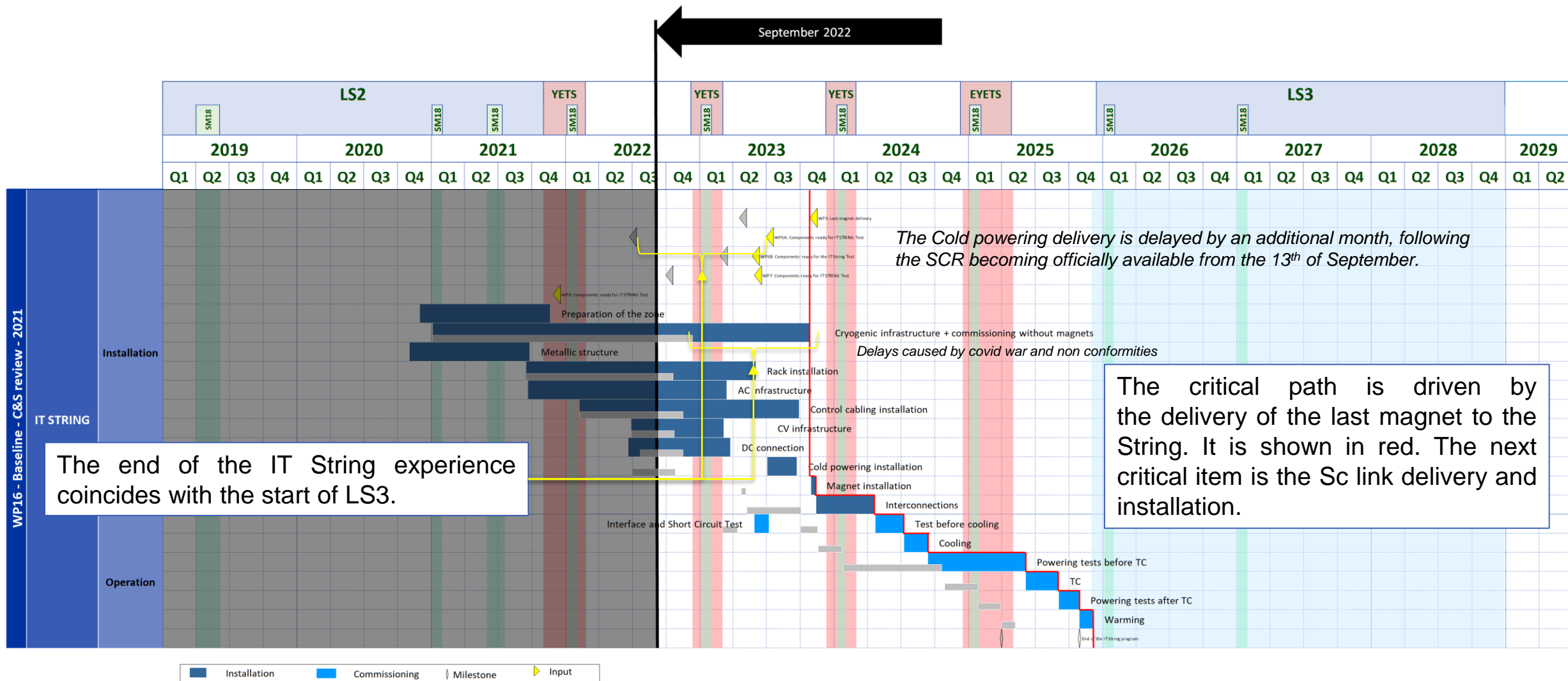

# HL-LHC Collaboration Board

12<sup>th</sup> HL-LHC  
Collaboration  
Board meeting

Plus participants  
connected  
via Zoom



# HL-LHC Collaboration Board

## HL-LHC CB Chairs

2011 to 2015 (FP7-HiLumi)

2015 to 2018

2018 to 2022

Elected 2022



Andy Wolski (UNILIV)



Rob Appleby (UNIMAN)

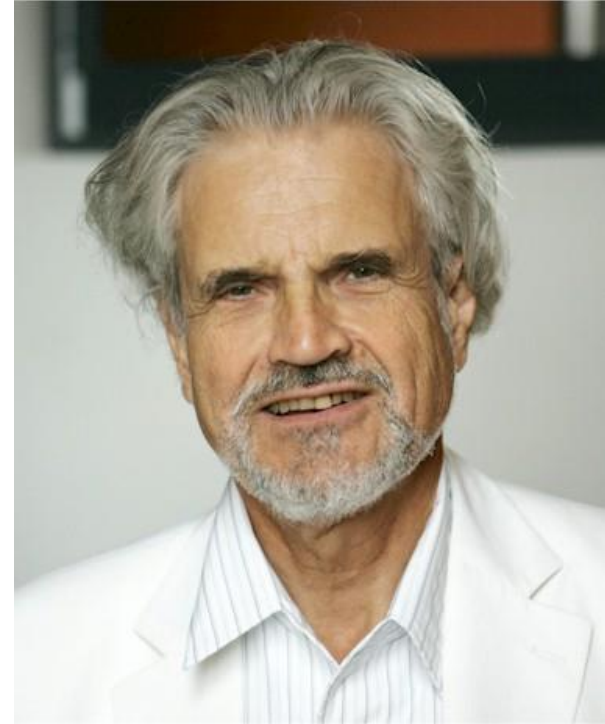

Tord Ekeloff (Uppsala U.)



Philip Borrows (Oxford U.)

# HL-LHC Collaboration Board

## 12<sup>th</sup> HL-LHC Collaboration CB Dinner

Linnaeus Garden and Museum



# Proposal for the 13<sup>th</sup> HL- LHC collaboration meeting 2023 in Vancouver, BC, Canada

O. Kester  
Director, Accelerator Division

2022-09-22

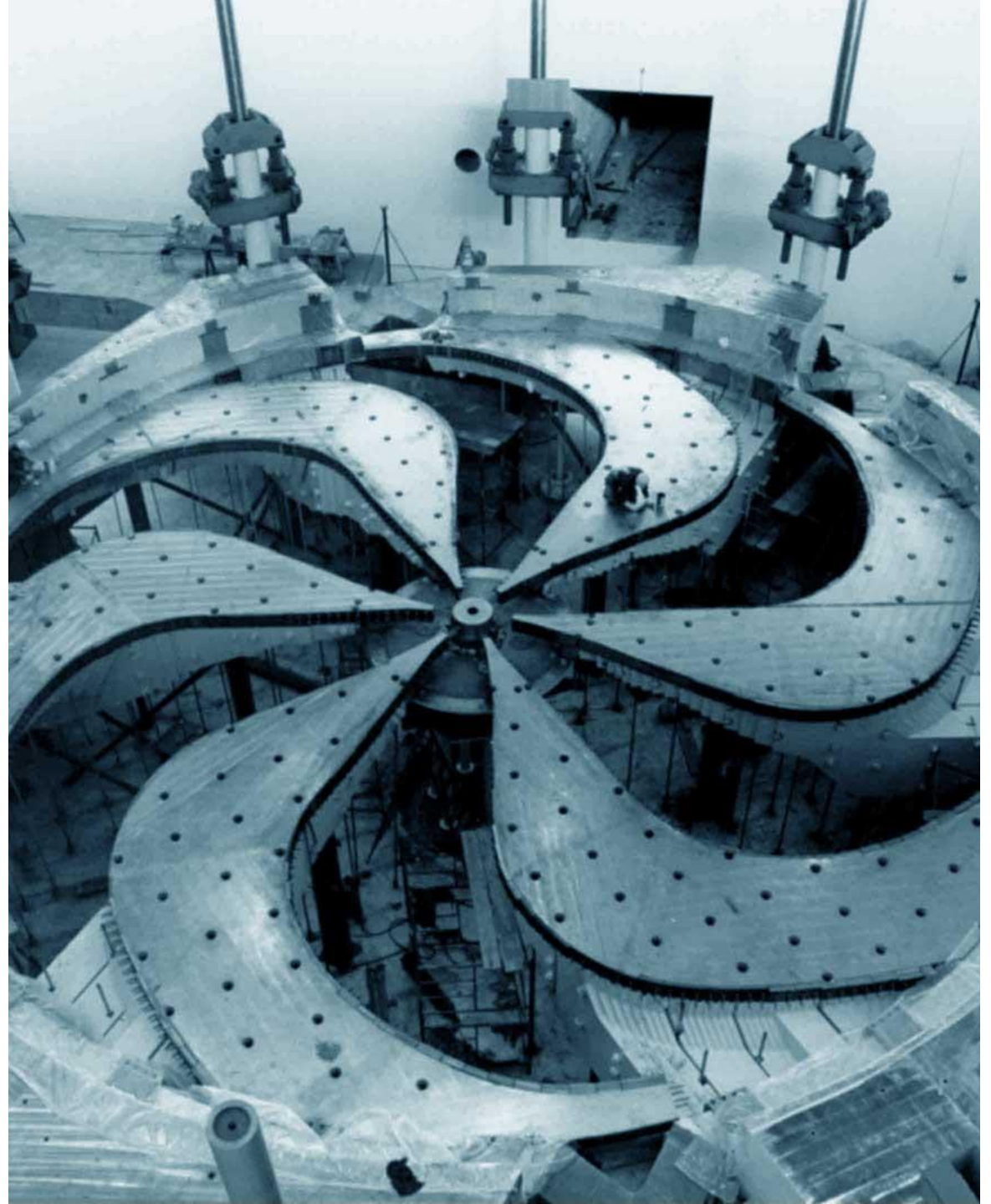

UBC campus



# Time to Close the Meeting



Wishing you all a safe trip home!