



# **X-Band BOC Cavity**

## ***Design review***

## ***Fabrication sequence***

E.Berthomé – EN/MME

2022-05-20

# General overview of fabrication sequence

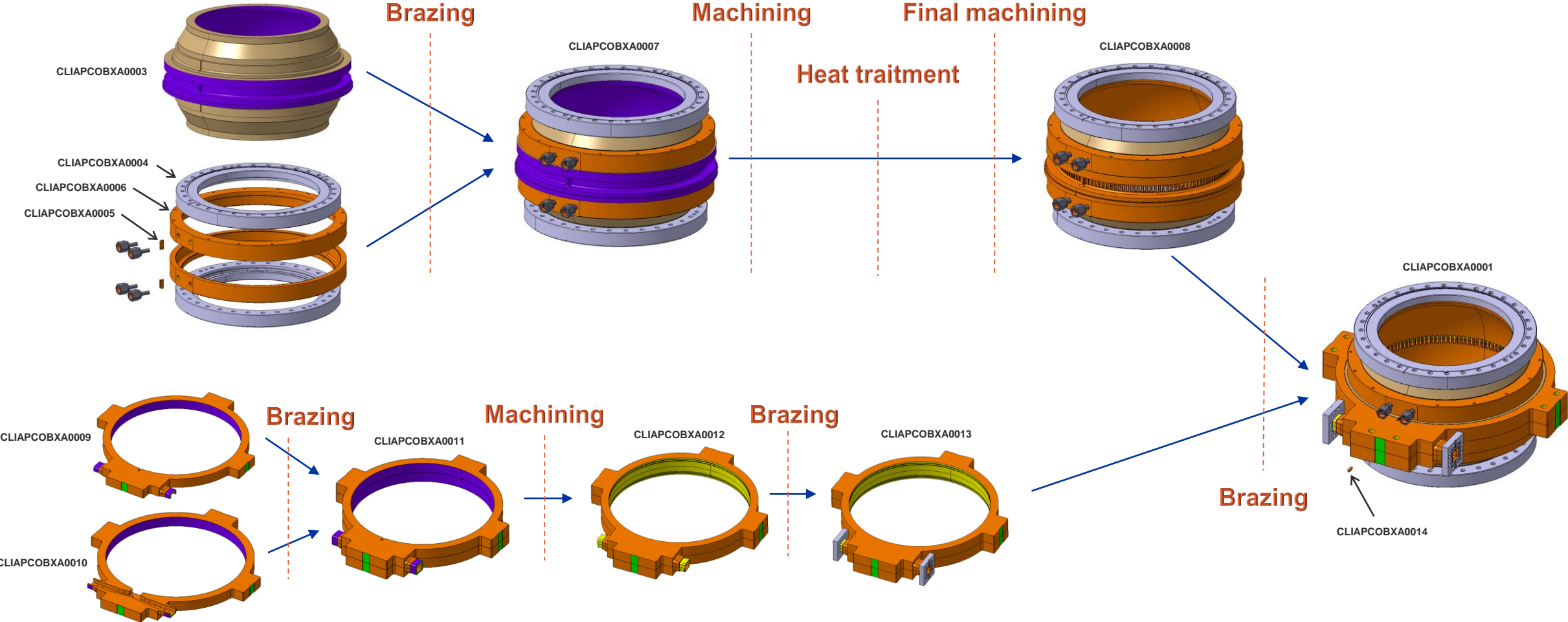

# Design of cavity support

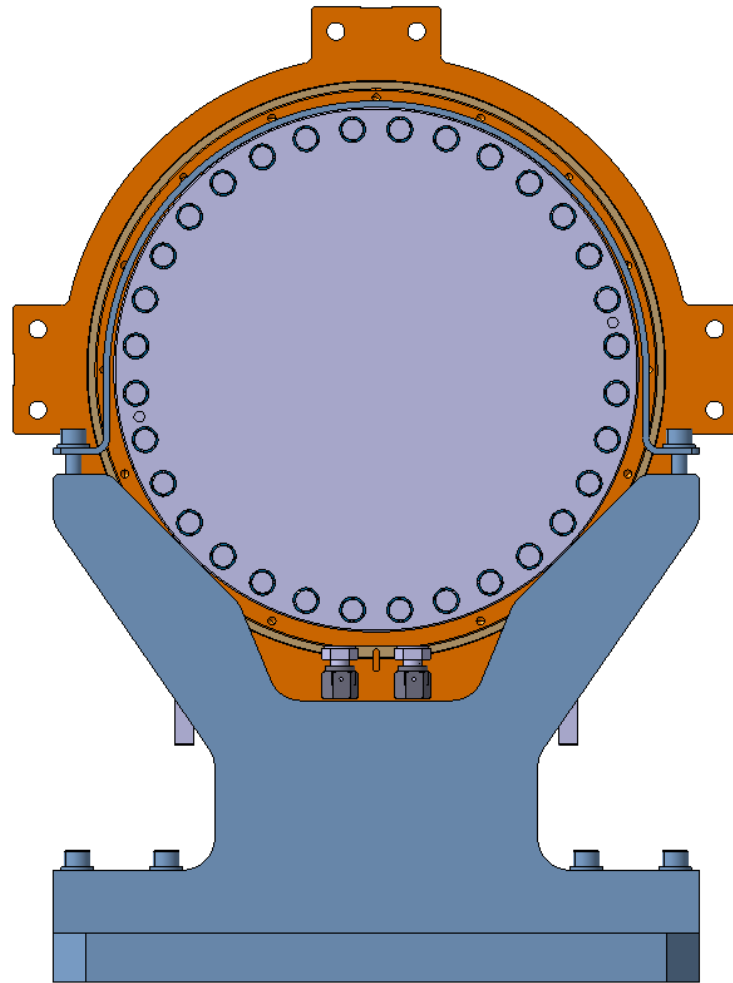
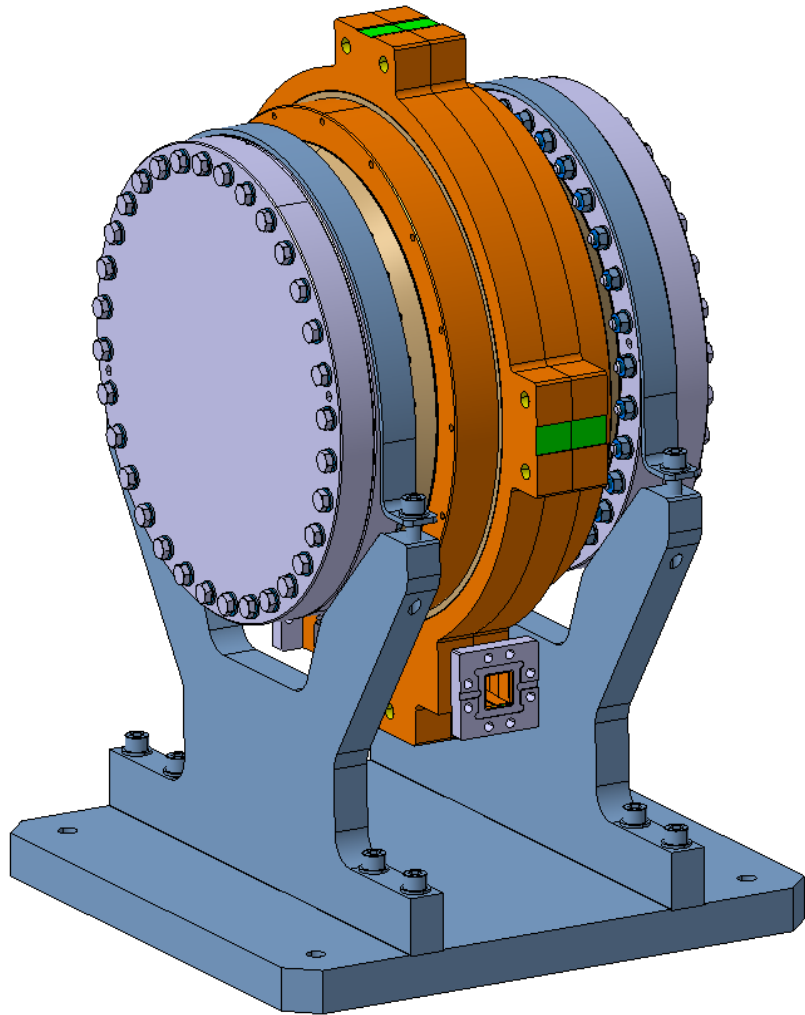

CLIAPCOBXA0002

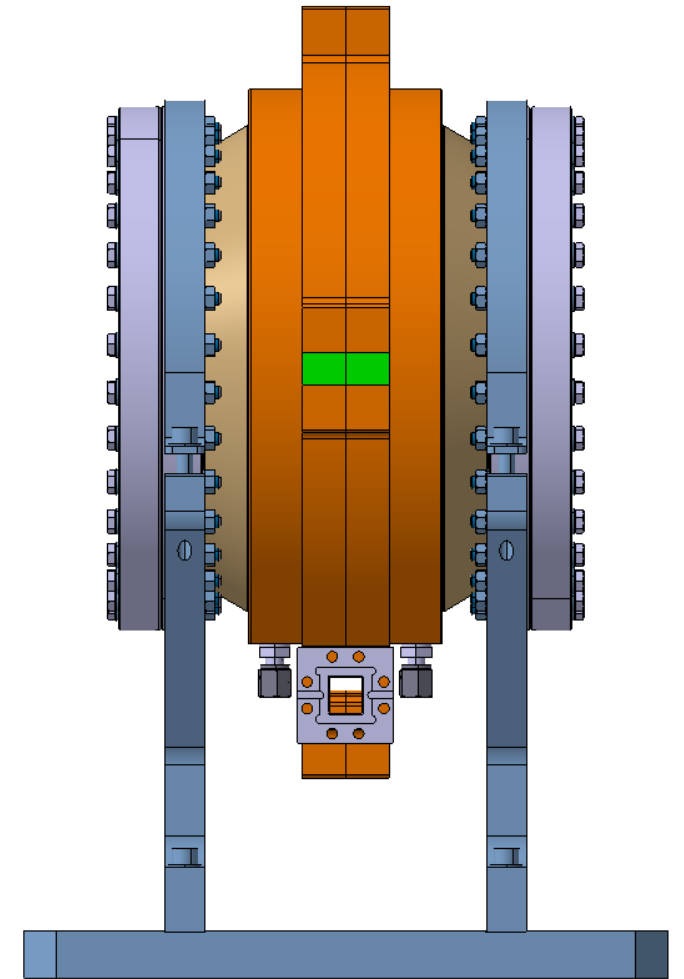

If the end-fitting nut is silver plated,  
it should be unplated before brazing.

Swagelock  
VCR end-fitting

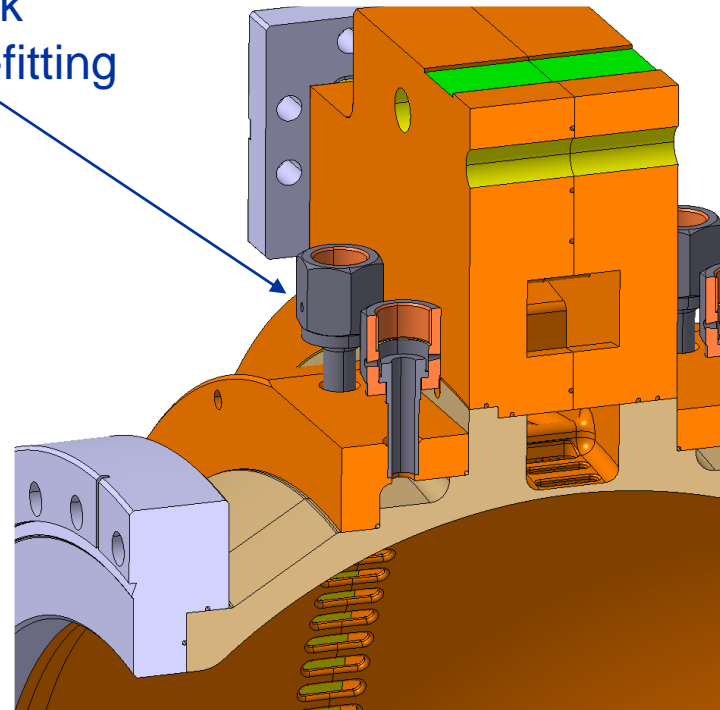

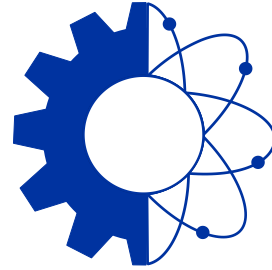

**ENGINEERING  
DEPARTMENT**

[home.cern](http://home.cern)