

Meeting Introduction and WCTE Status and Plans

Mark Hartz

WCTE Collaboration Meeting, July 19, 2022

Welcome

- We will hold the collaboration plenary session on July 19 (today), 21 (Thursday) and 22 (Friday)
- We plan to start the sessions at 14:00 CEST and finish by as close to 17:30 CEST as possible
- The meeting page is located at: <https://indico.cern.ch/event/1164299/>
- The meeting is a hybrid meeting with some connecting online. Connection information is at: <https://indico.cern.ch/event/1164299/videoconference/>
- The meeting room is also reserved for the mornings and on Wednesday
- If you need another room for a parallel meeting, we can ask the Neutrino Secretariat

Meeting Location

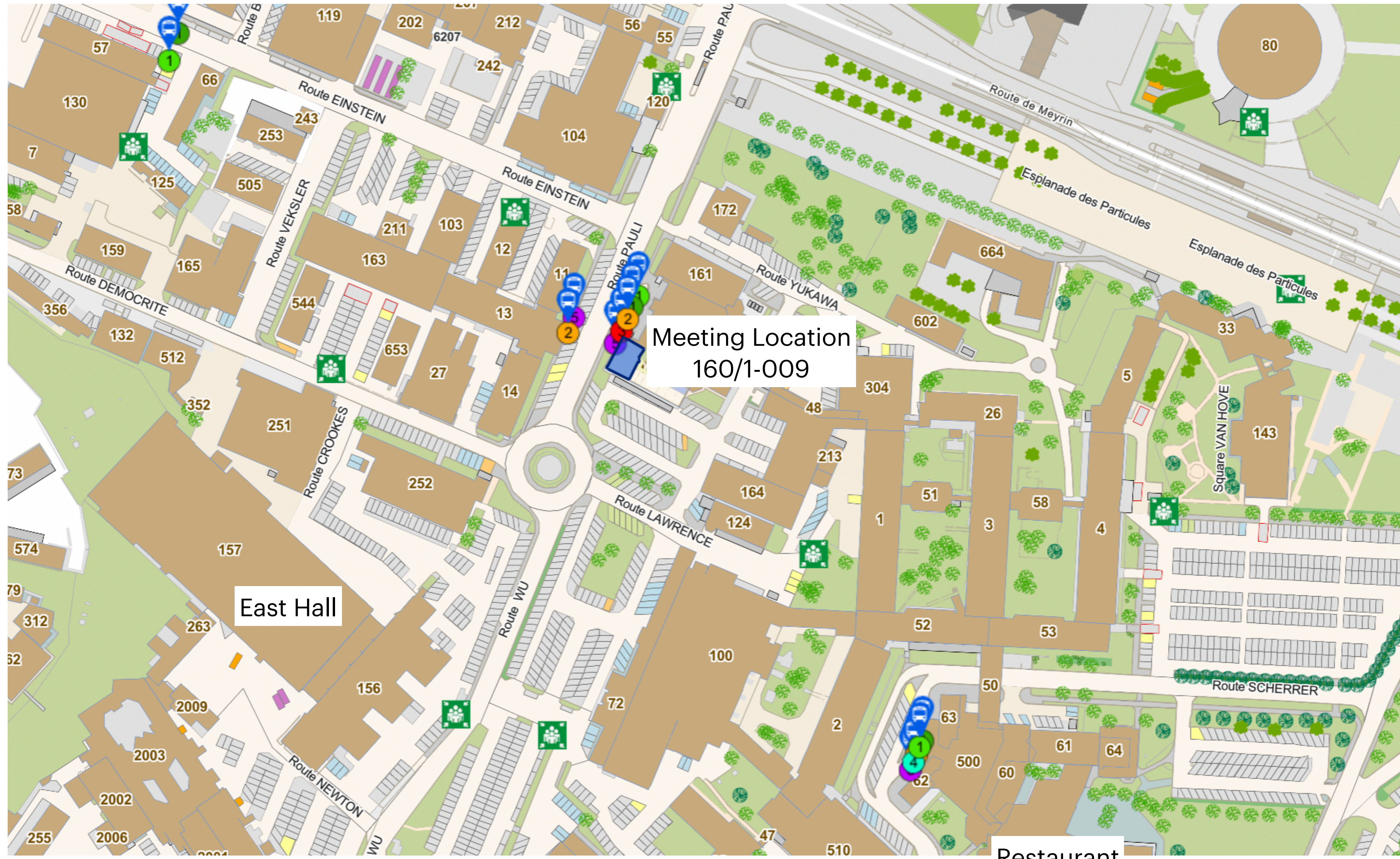

Meeting Agenda - Tuesday

14:00	Introduction <i>160/1-009, CERN</i>	<i>Mark Patrick Hartz</i> 14:00 - 14:30
15:00	Mechanical Systems <i>160/1-009, CERN</i>	14:30 - 15:45
16:00	Health Break <i>160/1-009, CERN</i>	15:45 - 16:05
	Mechanical Systems <i>160/1-009, CERN</i>	16:05 - 16:50
17:00	Water Systems <i>160/1-009, CERN</i>	16:50 - 17:30

Meeting Agenda - Thursday

14:00	multi-PMTs and Electronics <i>160/1-009, CERN</i>	14:00 - 15:35
15:00	Health Break <i>160/1-009, CERN</i>	15:35 - 15:55
16:00	multi-PMTs and Electronics <i>160/1-009, CERN</i>	15:55 - 16:30
	DAQ & Triggering <i>160/1-009, CERN</i>	16:30 - 16:50
17:00	Beam <i>160/1-009, CERN</i>	16:50 - 17:35

Meeting Agenda - Friday

14:00	Mechanical Systems <i>160/1-009, CERN</i>	14:00 - 14:15
15:00	Calibration Systems <i>160/1-009, CERN</i>	14:15 - 15:55
16:00	Health Break <i>160/1-009, CERN</i>	15:55 - 16:15
17:00	Software & Analysis <i>160/1-009, CERN</i>	16:15 - 17:42
18:00	Closeout <i>160/1-009, CERN</i>	17:45 - 18:00

WCTE Status

- WCTE was approved by the CERN Research Board in March 2022 with a CERN budget of ~170 kCHF
- We are now preparing the MoU with CERN
 - Meeting with institutional representatives for planning in May
 - Collecting inputs from each country - will reach out soon if haven't received them already
- Original plan was for operation in 2023, but schedule has moved to 2024 (more later)
 - Move to 2024 is acceptable from CERN perspective
- Meetings with CERN safety and transport groups have started

WCTE Structure

Collaboration Officers

Spokesperson: M. Hartz

CERN Liaison: M. Scott

Safety Officer: S. Bordoni

Technical Coordinator: TBD

Work Package Groups and Leaders

Beamline Systems: M. Pavin

Mechanical Systems: C. Garde, P. Fernandez

Water Systems: P. de Perio

mPMTs & Electronics: T. Lindner, M. Ziembicki

DAQ & Triggering: B. Richards

Calibration Systems: P. de Perio, M. Scott

Analysis and Software: L. Anthony

Please work with the relevant work package leaders on the development of the WCTE systems

Important Discussions - Beam

- In order to collect low momentum pion data, our baseline design includes two configurations
 - Secondary: electrons/positrons and muons directly from T9 secondary beam
 - Tertiary: low momentum pions and protons from a tertiary production target
 - Includes silicon tracker+Halbach array magnet spectrometer to measure particle momenta
- With magnet power supply upgrades, T9 can now operate down to low momenta
- Do we need the tertiary beam configuration
 - Are pion rates sufficient in the secondary beam
 - Can we select particles with sufficient purity?

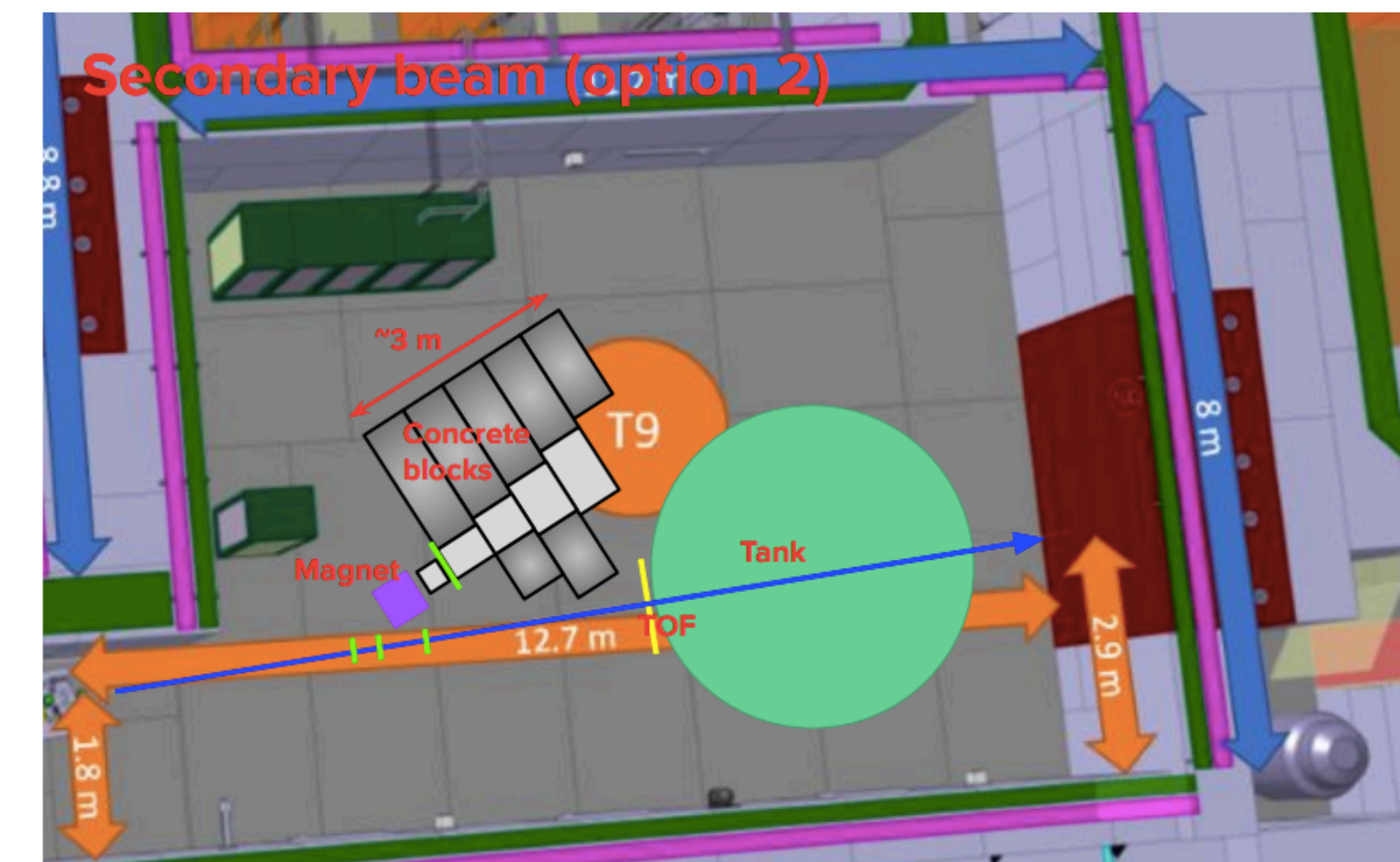
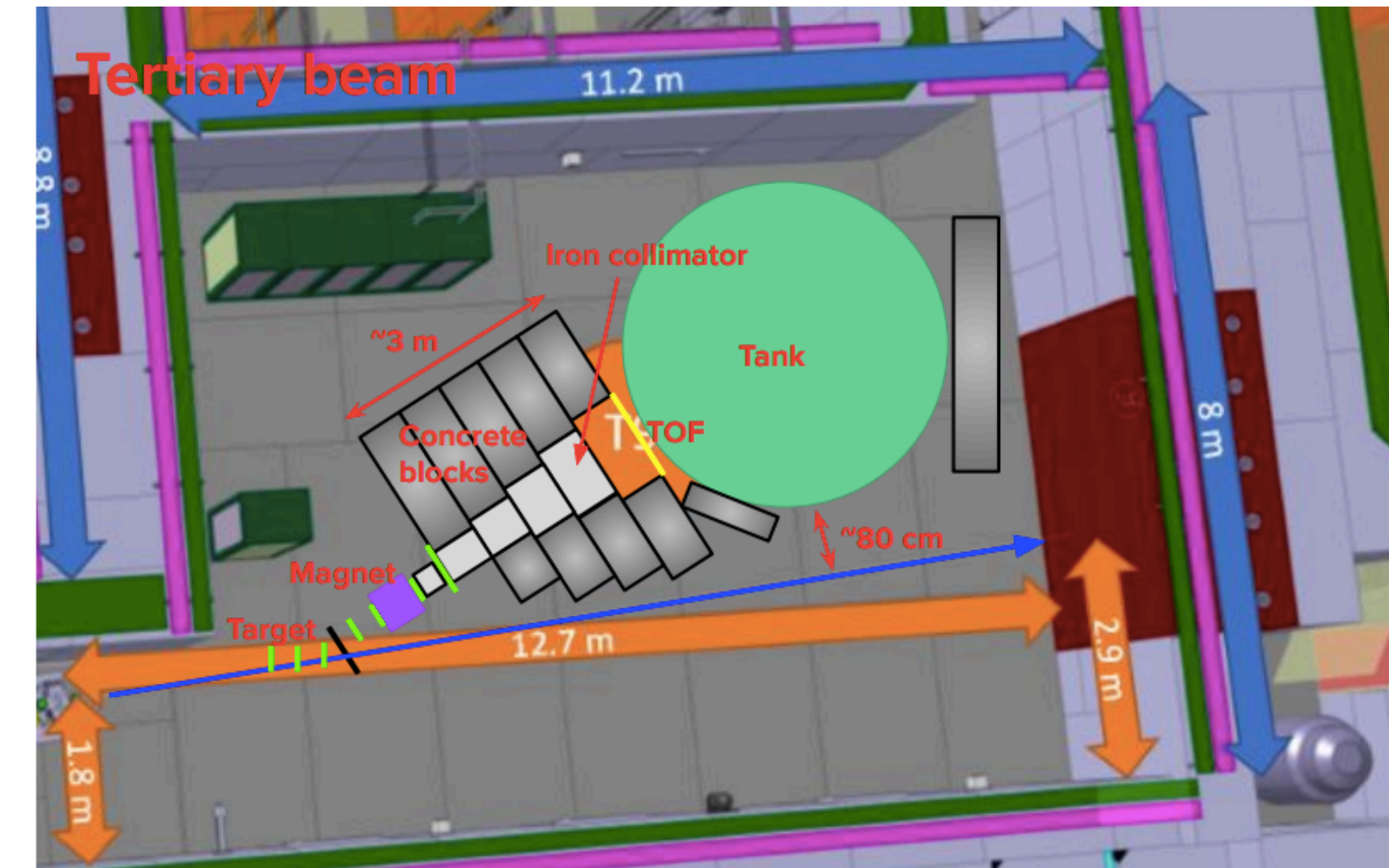

Analysis Questions for Beam Change

- What are the lowest proton and pion momenta at which we need to operate?
 - Protons above ~ 400 MeV/c for secondary neutron production?
 - Pions above ~ 200 MeV/c for $K \rightarrow \pi^+\pi^0$ in proton decay channel?
- What level of purity is needed for each particle type?
 - Muons are rejected by factor of $\sim 10^3$ - 10^4 for electron neutrino measurements
 - Less than 10^{-3} contamination of electrons in muon sample?
 - What pion purity is necessary to study pion misidentification as electrons?

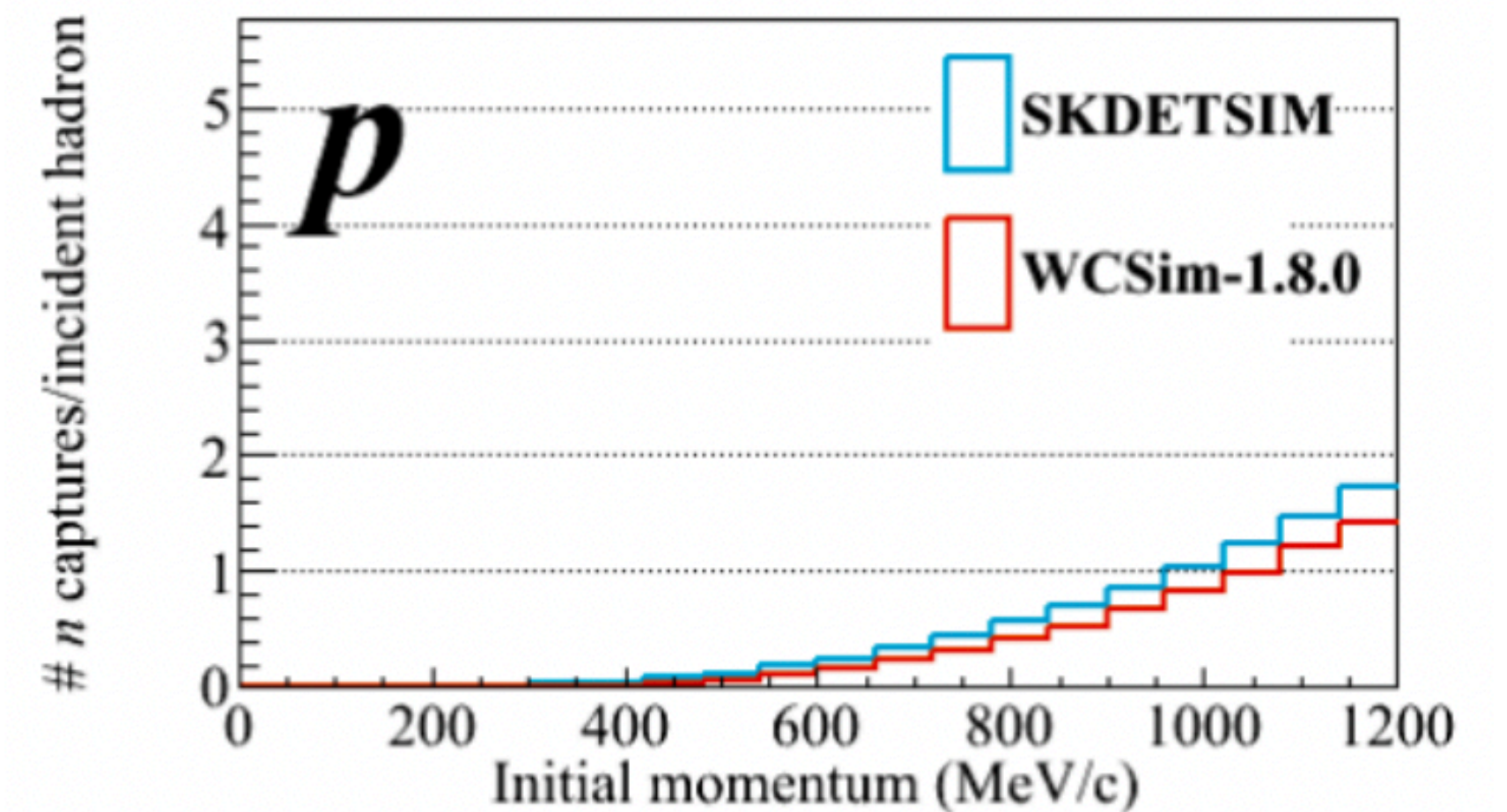

Beam Studies

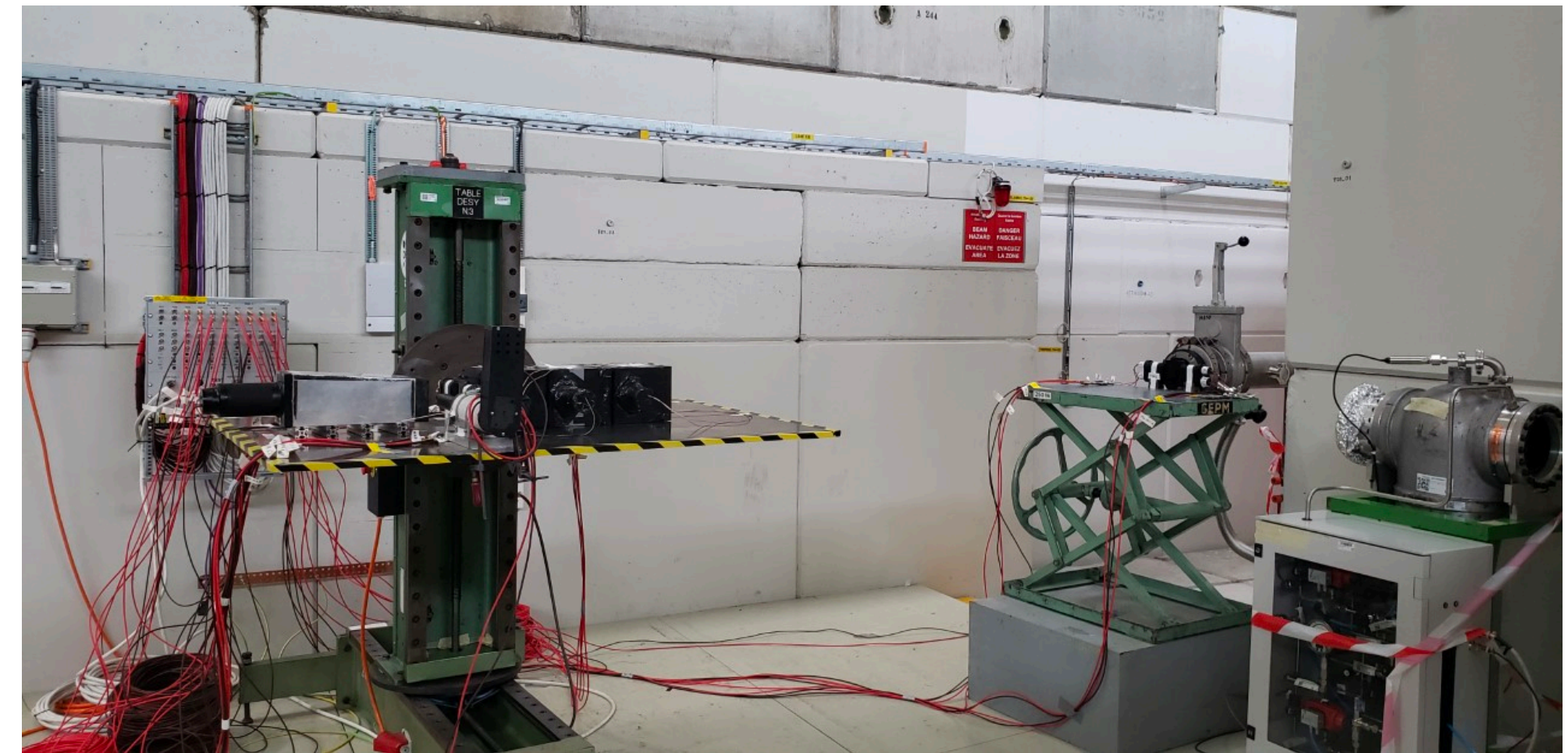

Layout Top View

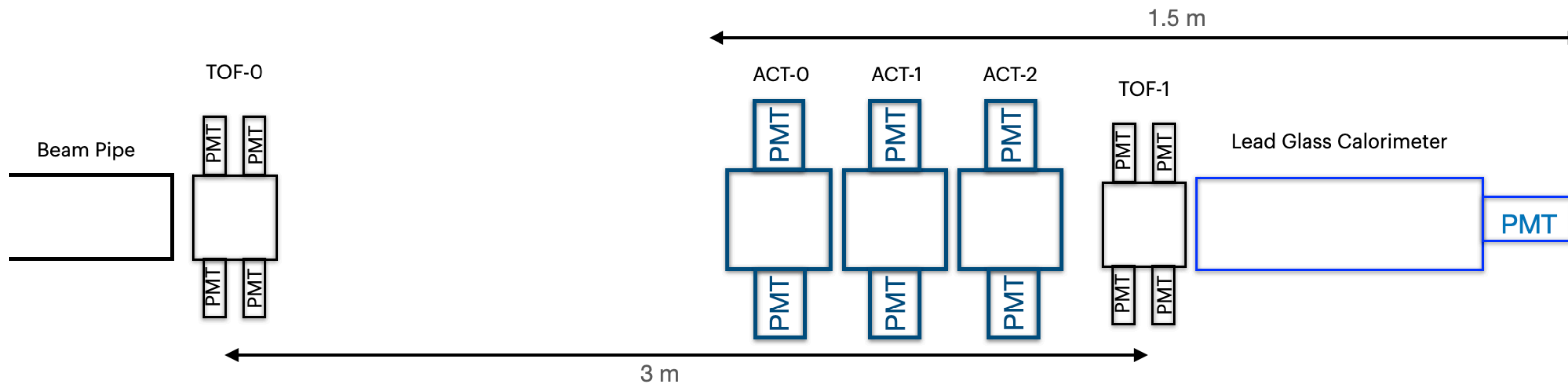

- For the past week, we have collected low momentum data with time-of-flight and aerogel Cherenkov threshold detectors to measure the beam composition
- Preliminary results in Thursday's session

Important Discussions - Mechanical Systems

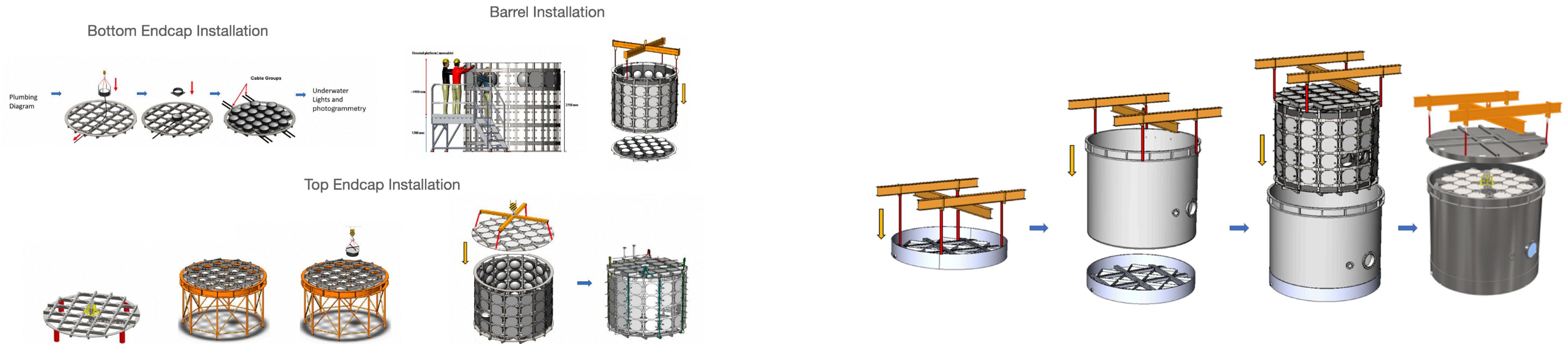

- The assembly procedure is being developed
- Discussion with CERN about:
 - Safety of procedures
 - Requirements and location for assembly and transport
- We also need to determine the personnel necessary for the detector assembly

Important Discussions - mPMT/Mechanical Integration

- Integration of the mPMTs with the mechanical structure should be finalized soon
- Major point of discussion is cabling, feedthrough and clearance for cables
 - Hope we can converge at this meeting
- How many Hyper-K style mPMTs will be installed in WCTE
 - Are these compatible with the mounting mechanism
- How will the black sheet be installed?

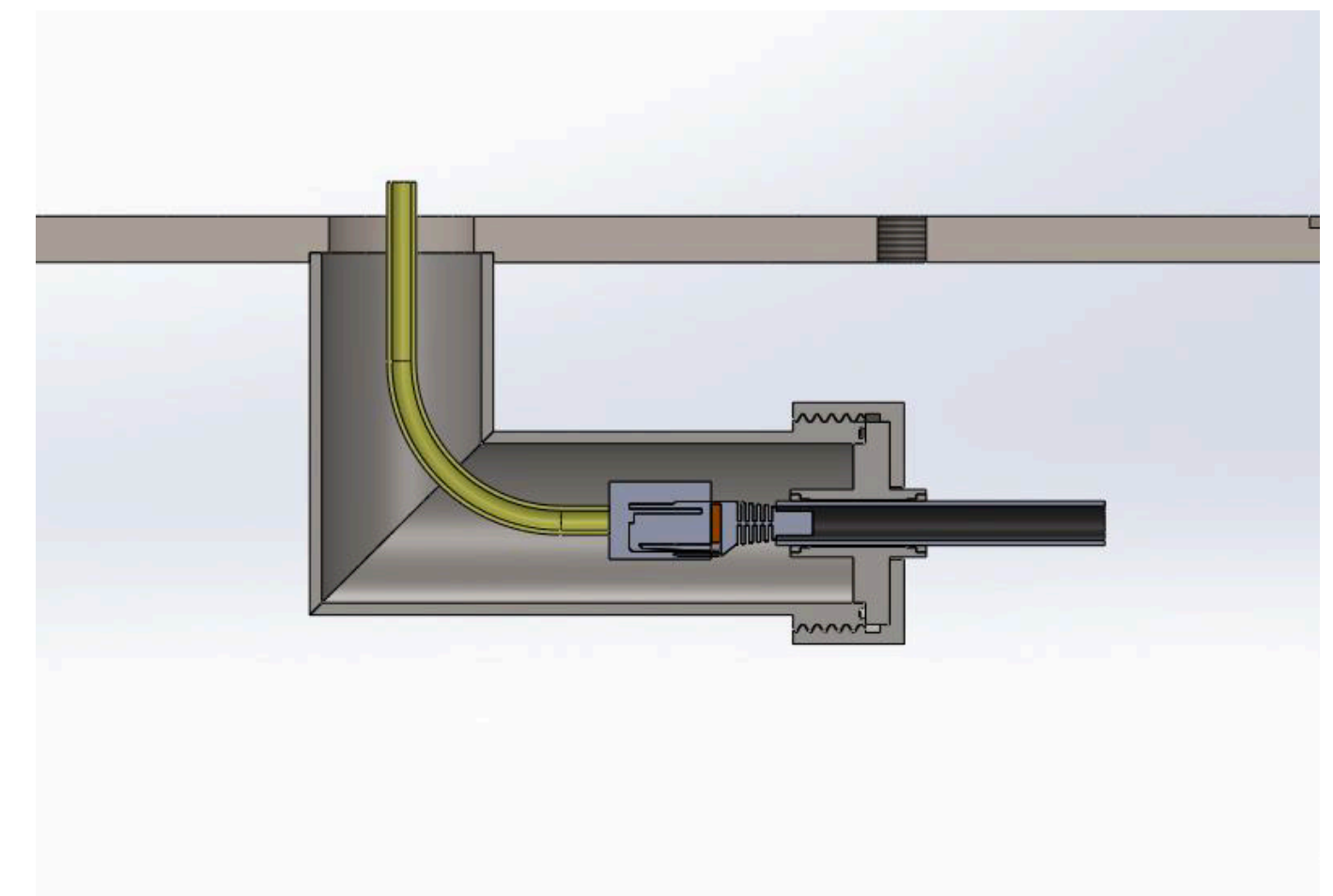
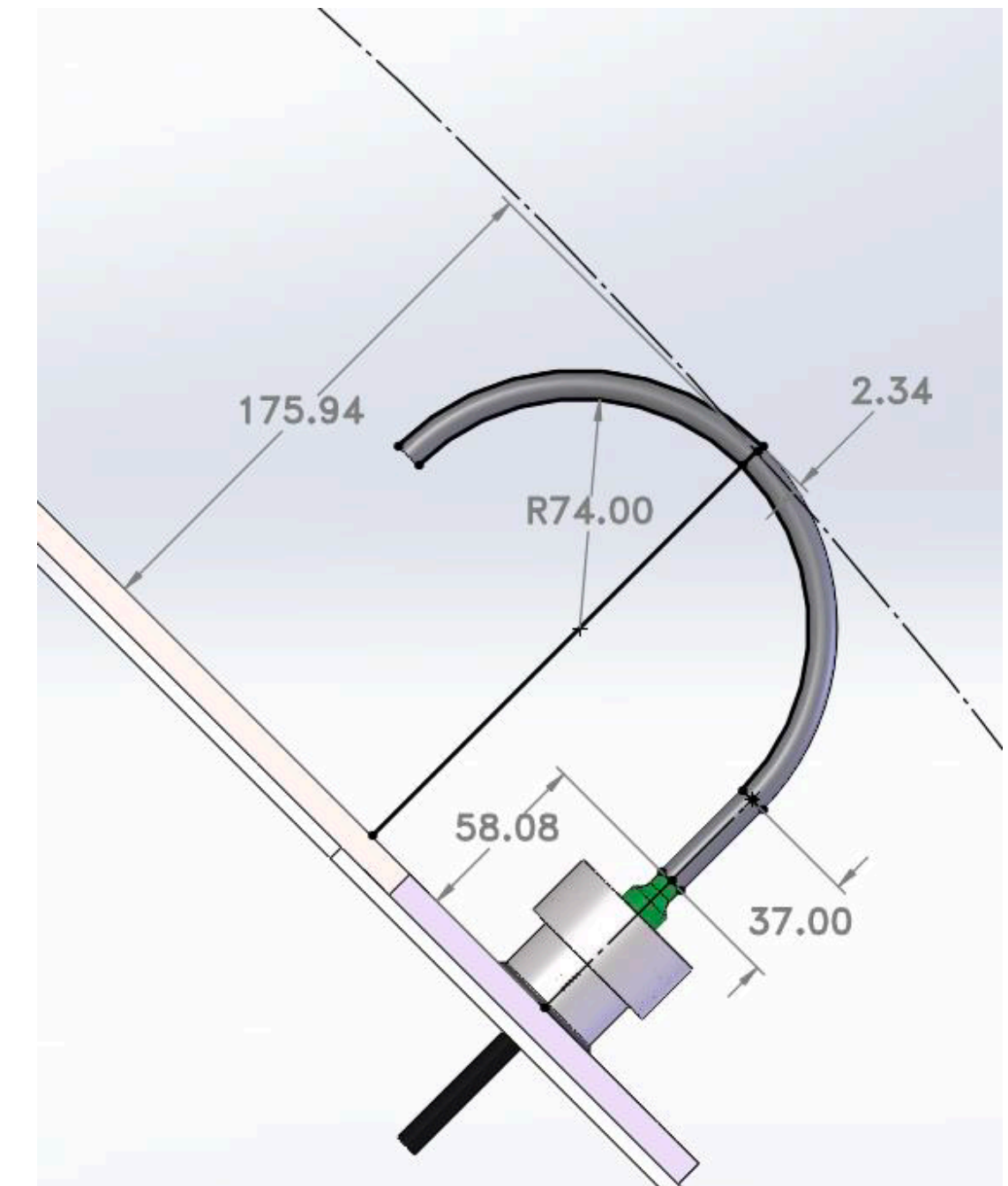

Important Discussions - Water System

- There are still a number of open questions and action items related to the water system
- What sub-systems (UV, ion exchange resins, micro/nano-filters, etc.) are necessary?
 - More in Patrick's talk
- Detailed design of gadolinium addition and removal systems must be developed and discussed with the safety group
- What chilling power is necessary?
- ...
- Funding scheme for water system is still being developed

Important Discussions - Integration

- Integration of systems should be discussed at this meeting with development of plans to converge
- Some important integration discussions:
 - All detectors and calibration with the DAQ and slow control
 - mPMT cabling and mounting with the support structure, tank and lid
 - Water system pipes with the support structure, tank and lid
 - Calibration sources with the CDS
 - ...

Missing Systems

- It is important for each work package group to identify any systems that don't have a responsible group or don't yet have funding
- Make sure that all details like cabling, connectors, consumables are considered
- Information of contributions must be collected for the MoU as well

Schedule Discussion

- The schedule in the WCTE proposal assumed detector assembly starting in late 2022 and operation of the WCTE from the start of beam in 2023
- Based on the impact of COVID-19 on detector development and funding requests, and the impact of global supply chain shortages, we need to delay WCTE by 1 year
- We plan to start the detector assembly in late 2023 with the start of operation in 2024

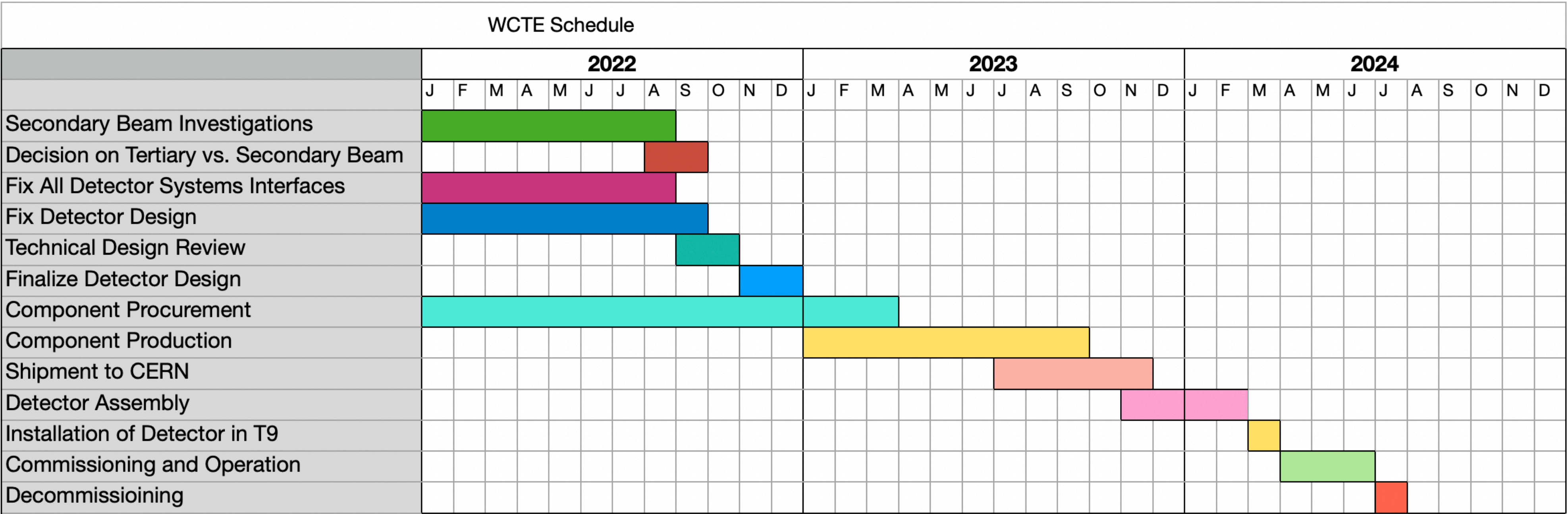

Schedule Discussion (2)

- We want WCTE to be the first experiment to run in 2024 so that we have time to install the detector in the experimental area and commission during the winter shutdown
- We heard that the winter shutdown in 2024 could be shorter and beam could start as early as February
 - Can we be ready?
- We need a more detailed assembly, installation and commissioning plan

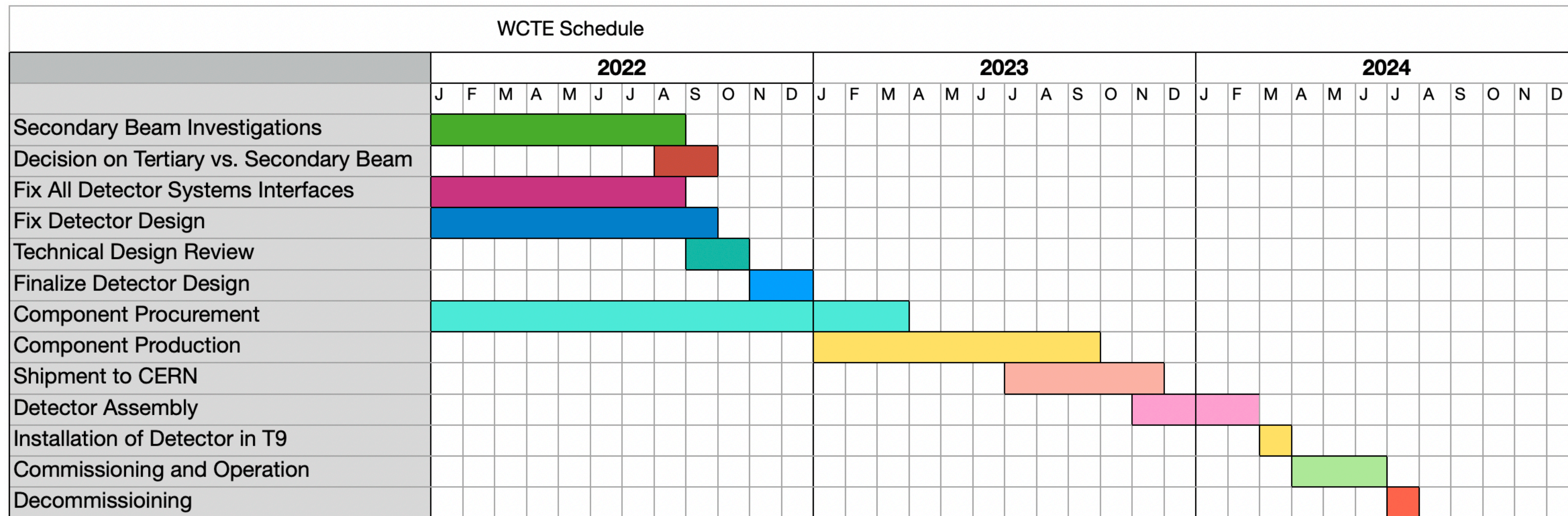

Schedule Discussion (3)

- In order to keep to the schedule, we should make import design decisions this year and fix the detector design
- Decision on secondary vs. secondary+tertiary beam by end of September
- Technical design document by the end of August with review and iteration by the end of October
- Finalize design in consultation with relevant CERN groups by the end of the year

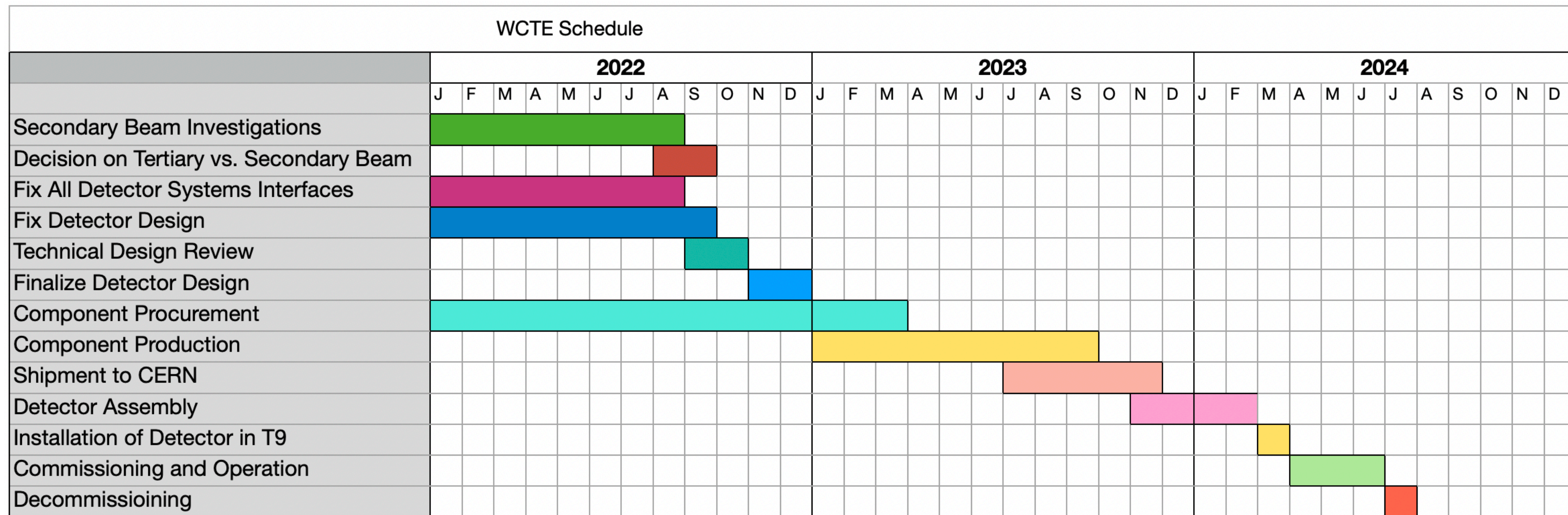

Summary

- WCTE has been approved by the CERN Research Board
- We now move to finalize the design of WCTE and move into the construction phase
- Operation of WCTE from start of beam time in 2024
- Many important aspects of design to finalize
 - Beam configuration
 - DAQ and synchronization of systems
 - Mechanical interface for components installed in the detector
 - ...
- Let's have a fun and productive meeting and work towards our goals

Extra Slides

Detector Dimensions Challenges

- WCTE detector will be lifted by crane into the T9 area
- Original height of 4.3 meters did not have enough clearance over the wall
 - Identified area (lower right) with extra 0.5 m of clearance, but not enough
 - Detector height must be reduced
- Detector diameter also needs to be reduced to <4 meters based on conversations with vendors about their capabilities to produce and transport tanks

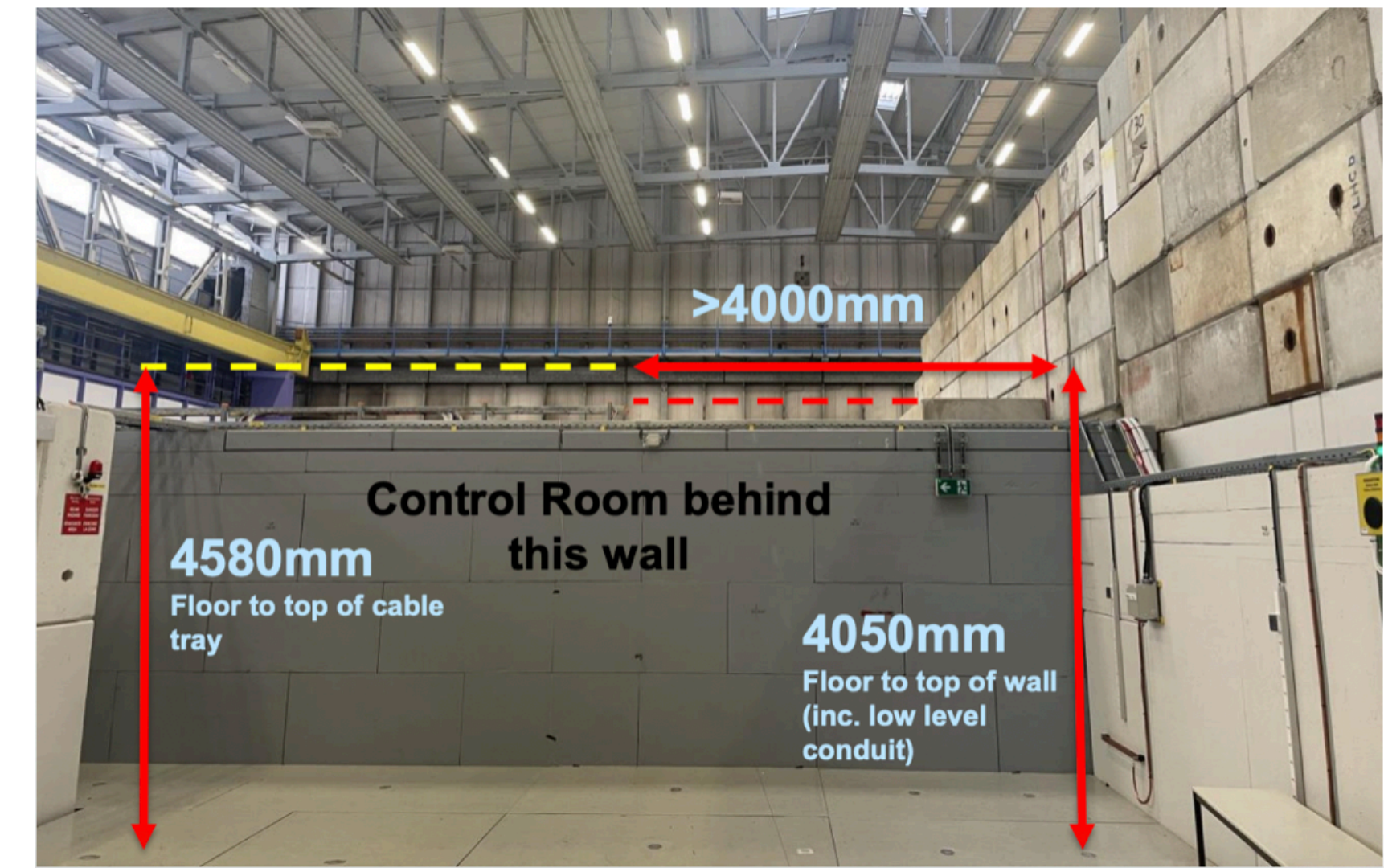
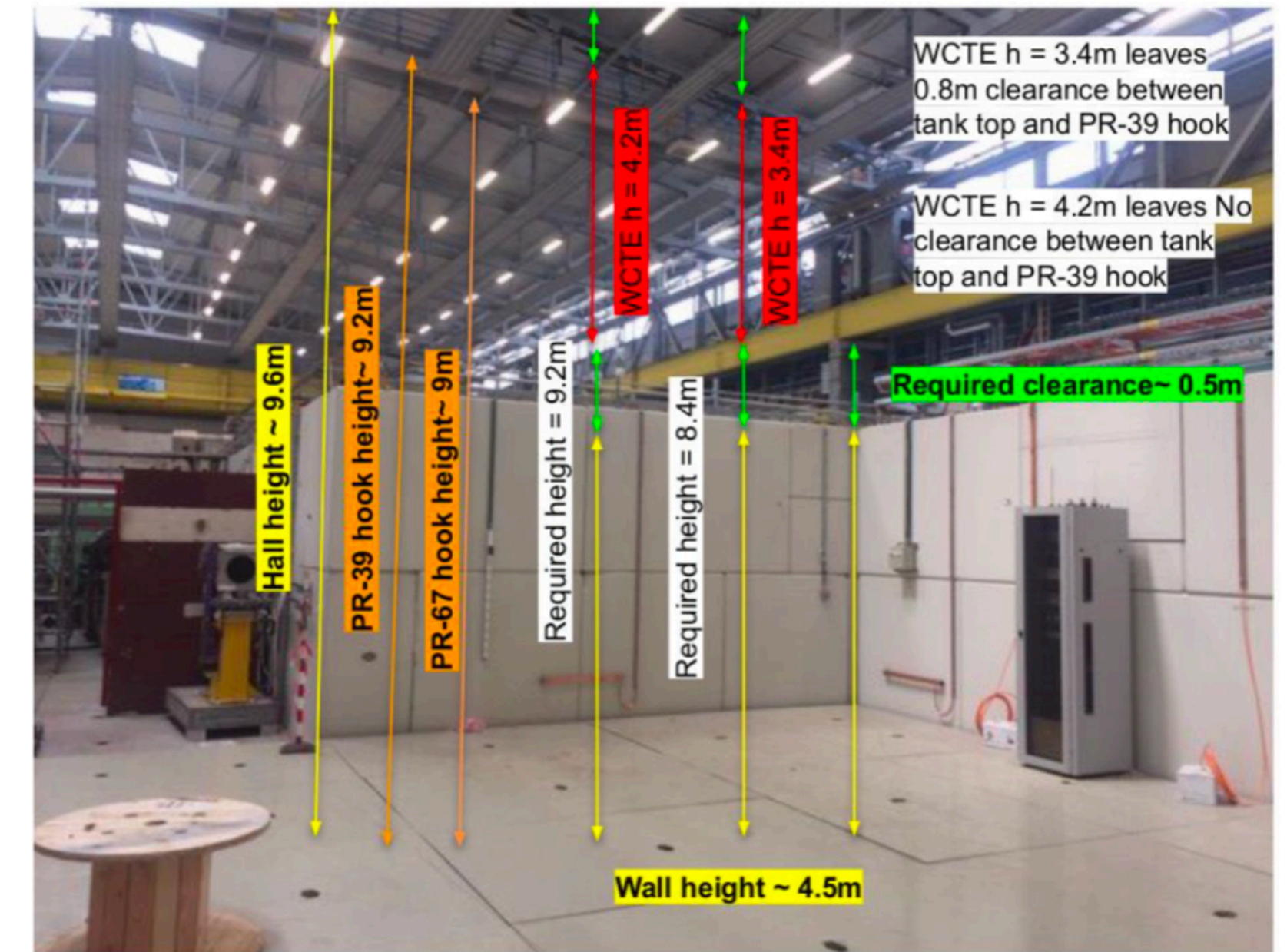

Detector Dimensions Change

Config	Columns	Rows	Height (mm)	Diameter (mm)	ID height (mm)	ID diameter (mm)
Original	18	5	4320	4022	3539	3621
Reduced diam 1	18	5	4200	3800	3539	3439
Reduced diam 2 (16c-5r)	16	5	4200	3800	3539	3427
Reduced height and diam (16c-4r)	16	4	3400	3800	2739	3427

- Studied different detector configurations with reduced rows and columns of mPMTs
- Converged on reducing columns from 18 to 16 and reducing rows from 5 to 4
 - No significant degradation of reconstruction performance observed
- Even with reduction, care must be taken with design of lifting beam
 - In discussion with the Engineering Department Handling Engineering (EN-HE) group

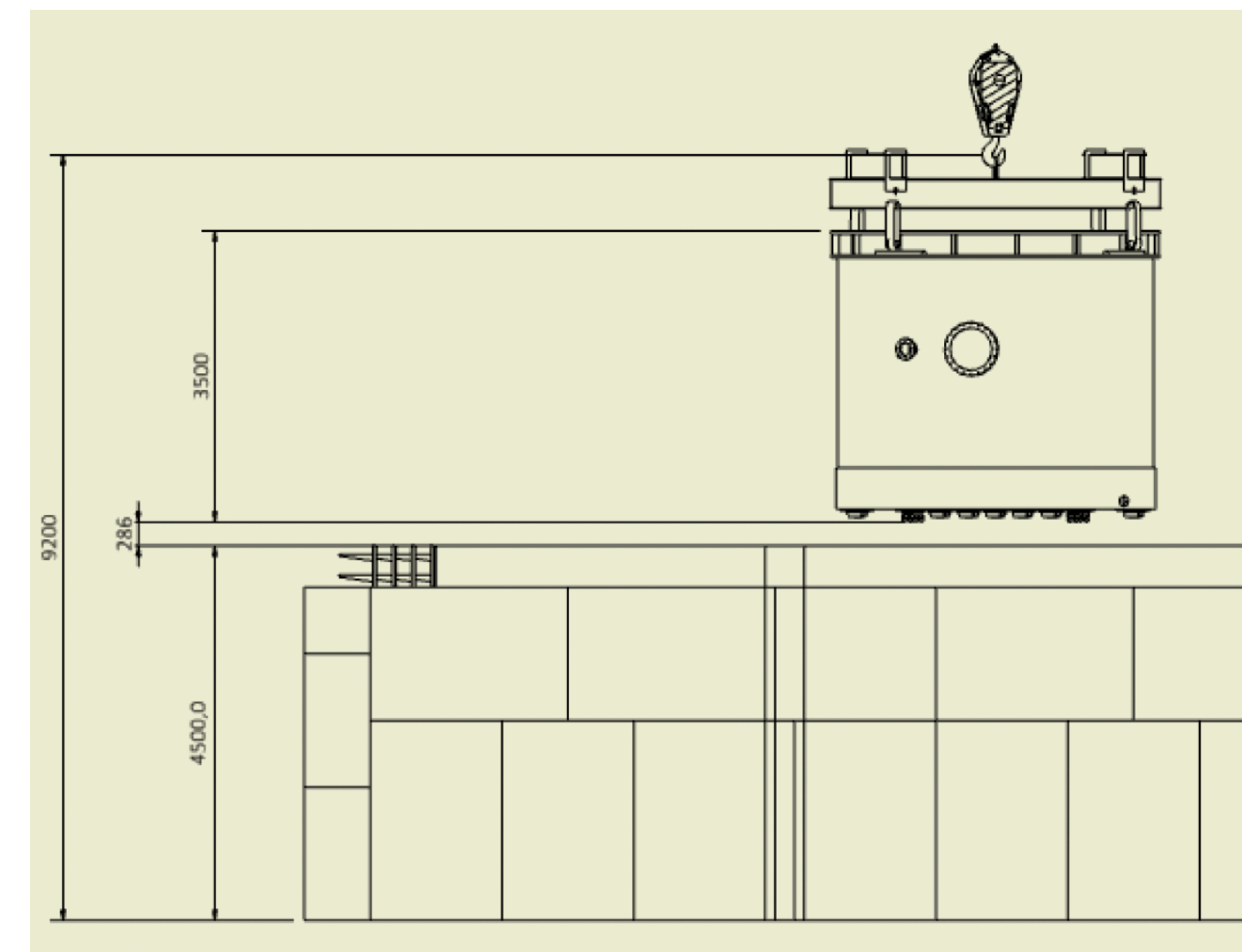

Status of Tank and mPMT Structure

- In progress to finalize tank and mPMT support structure and integration of the rest of detector components:
- Tank design elements being finalized:
 - Integration with railing system
 - Final design of beam windows
 - Final design of the lid to integrate pipes, cables and CDS
- mPMT structure design elements being finalized :
 - Integration of water pipes
 - Cable routing
 - Mounting of photogrammetry cameras and lights
 - Mounting of mPMTs and black sheets
- Quotation from five Spanish companies interested in the project for the latest design of tank and mPMT-support structure
 - Manufacturing time of 3-4 months
 - Transport time of ~1 week

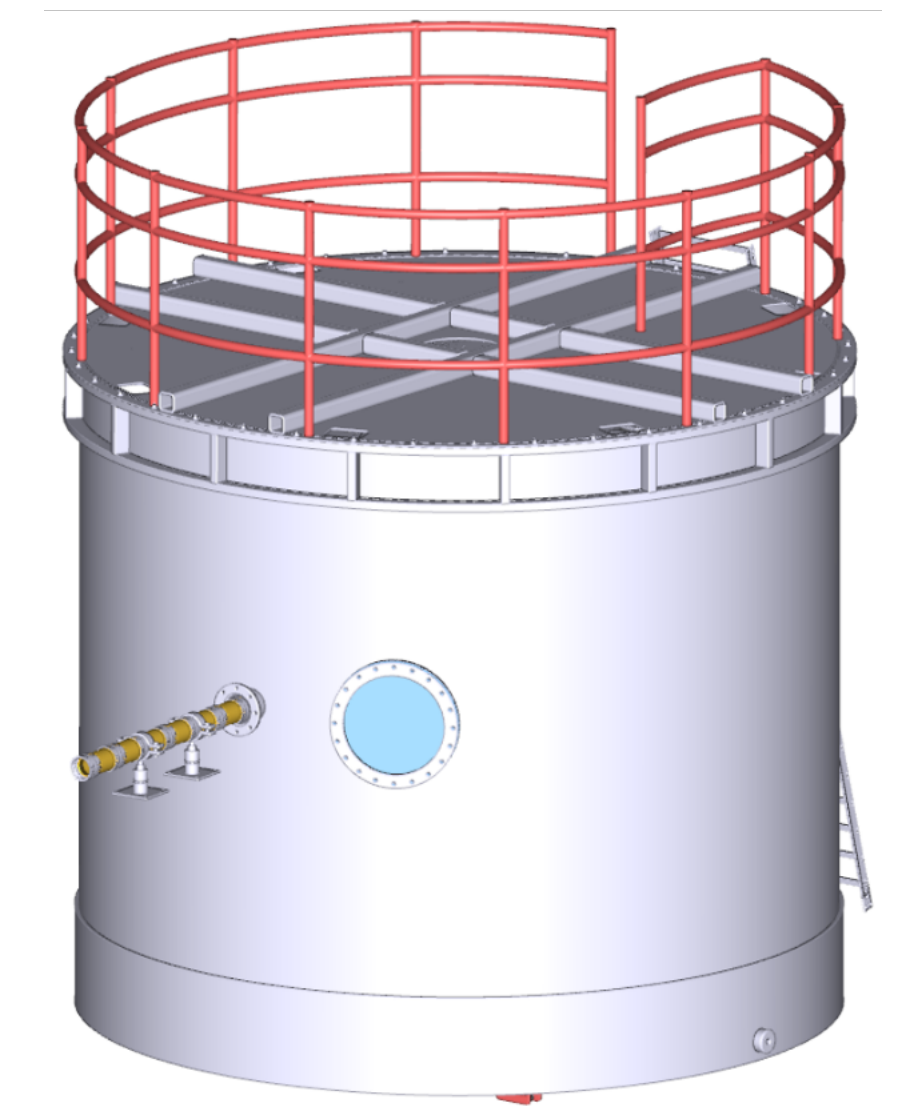
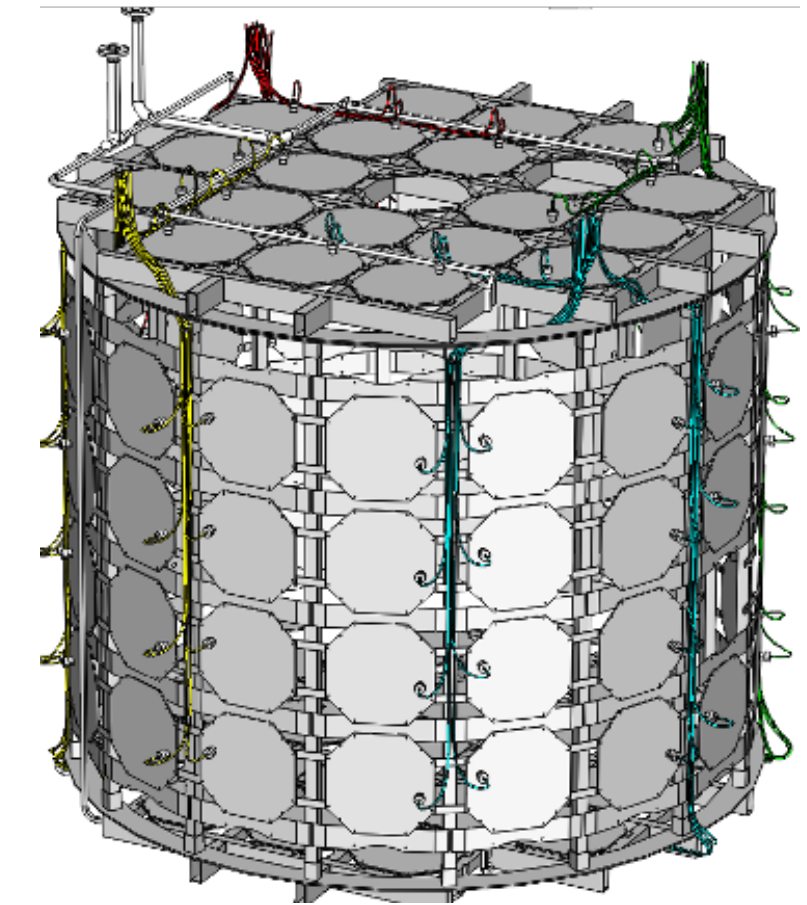

Detector Assembly Procedure

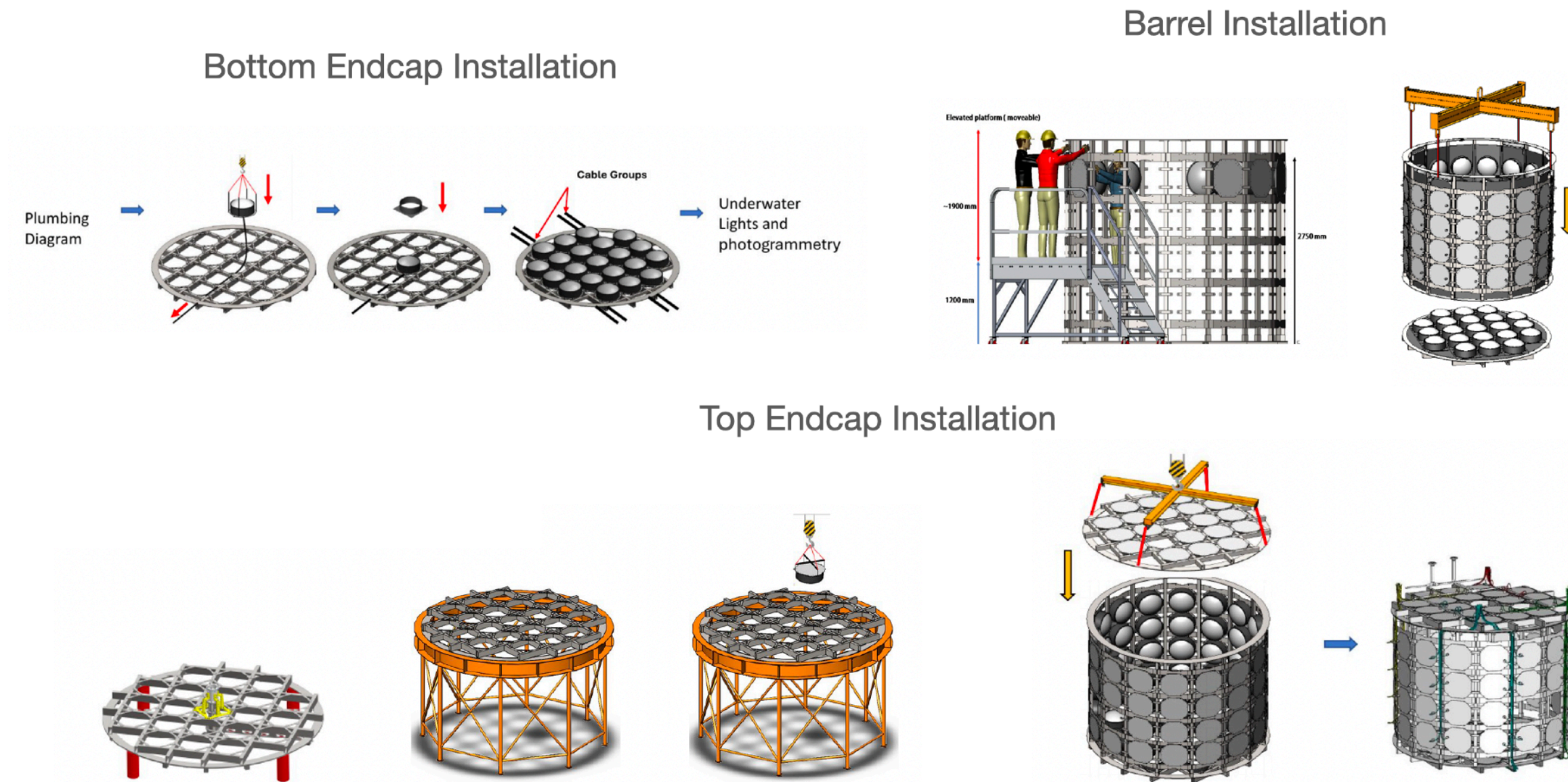

- Development of the detector assembly procedure is priority
- mPMTs will be installed on the bottom and top endcaps and barrel region of support structure separately
- We won't use welding, but rather fasteners and braces to attach the barrel and endcaps
- We will need a raised platform for workers installing the top mPMTs on the barrel
- We will need a structure hold the top endcap during mPMT installation

Detector Lifting

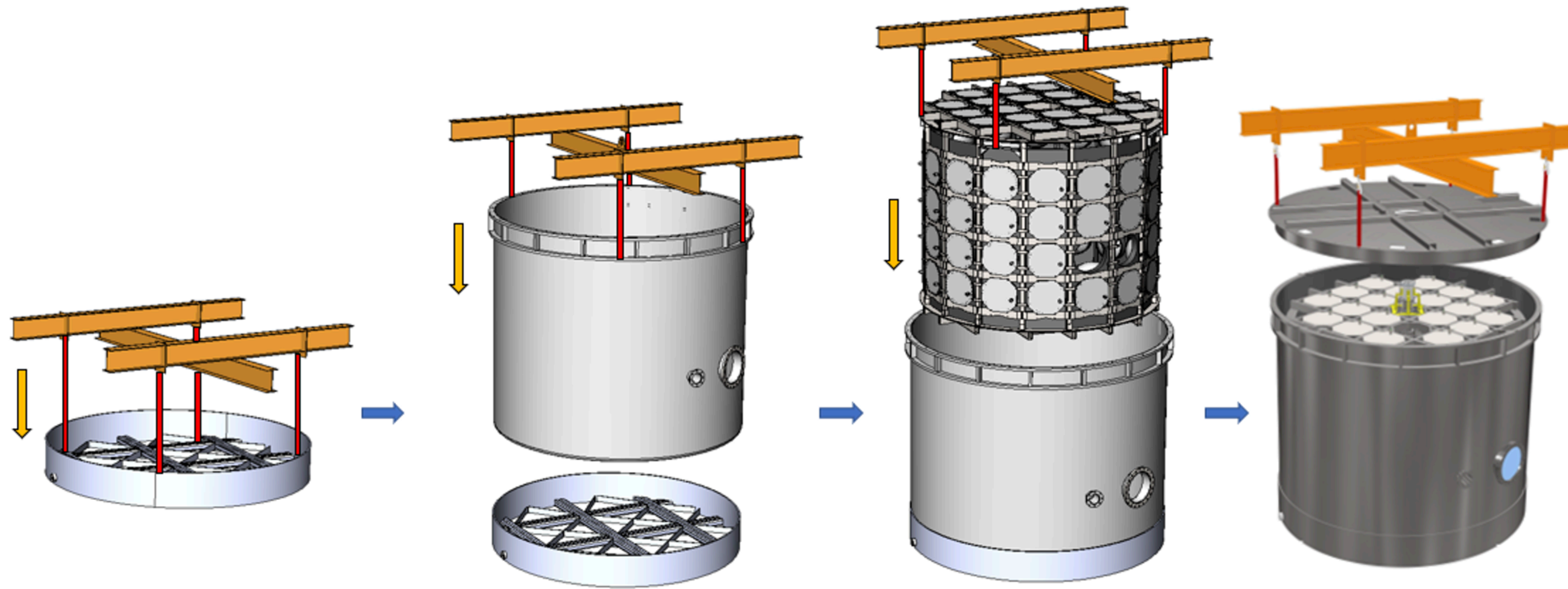

- The base structure, tank, populated support structure and lid will all be lifted into the experimental area separately
- The lifting points are being designed so that the same lifting beam can be used
- This requires transport of the populated support structure from the assembly to the experimental area while not yet installed in the tank

Assembly Area

- We are updating our requirements for the assembly area
- Requirements have not changed too much since the proposal, but we likely need more floor space
 - Original proposal: 15 m × 15 m
 - Updated estimate: 17.5 m × 26 m
 - Accommodates separate storage of the tank, base structure, lid and support structure before transport
- We are preparing an assembly document that we will share with the EP-Space group

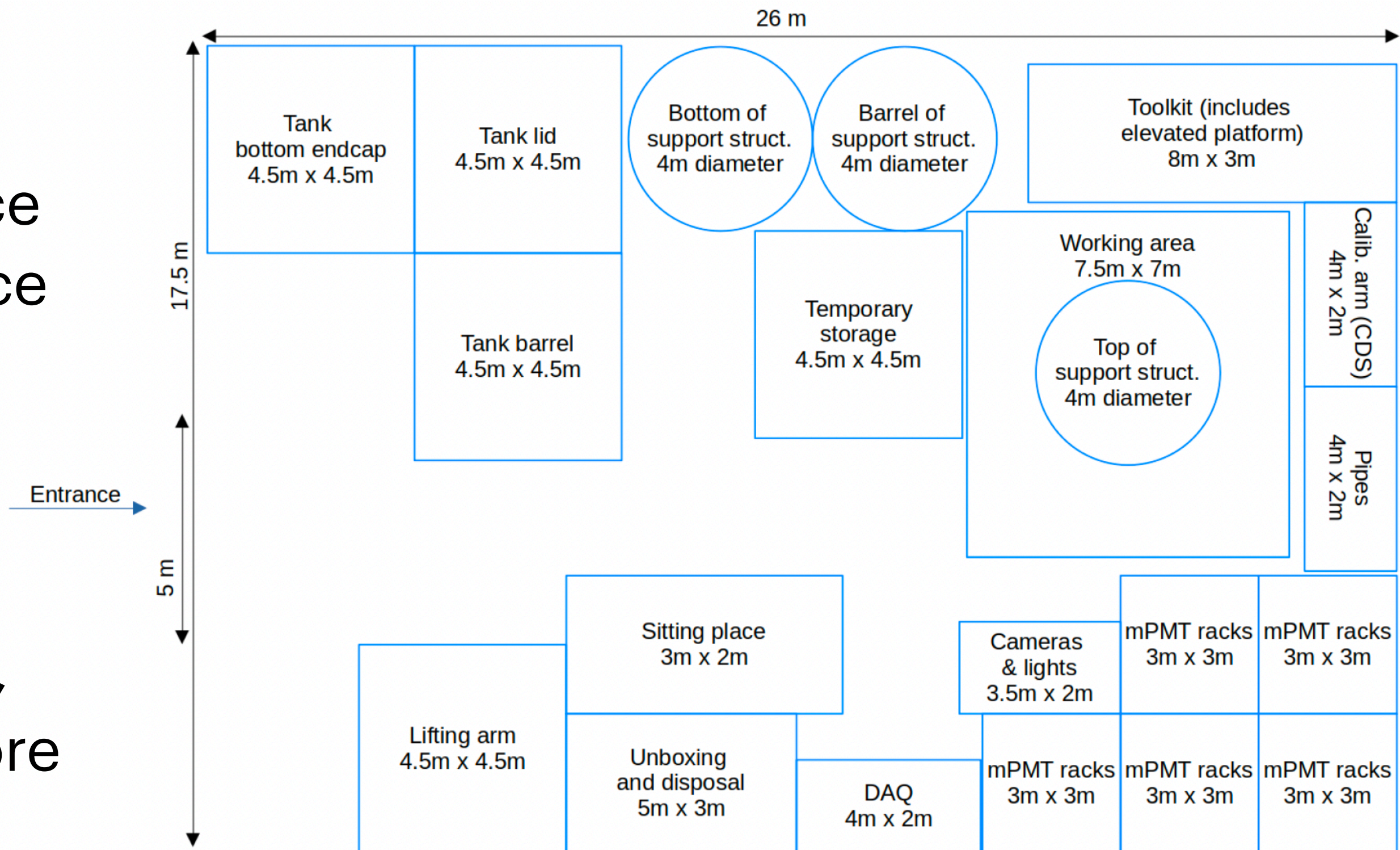

Experimental Beam Configurations

- Based on the capabilities of the pre-upgrade T9 beam, we designed the experiment with two configurations
- **Tertiary** - a tertiary production target ~ 3 m upstream of the detector with a spectrometer and collimator
 - Access particle momenta below 400 MeV/c
- **Secondary** - the detector sits directly in the secondary beam line
 - Best configuration for electron and muon fluxes
- Two configurations add complexity:
 - Two beam windows
 - Rail system to move detector
 - Spectrometer and collimator for tertiary configuration

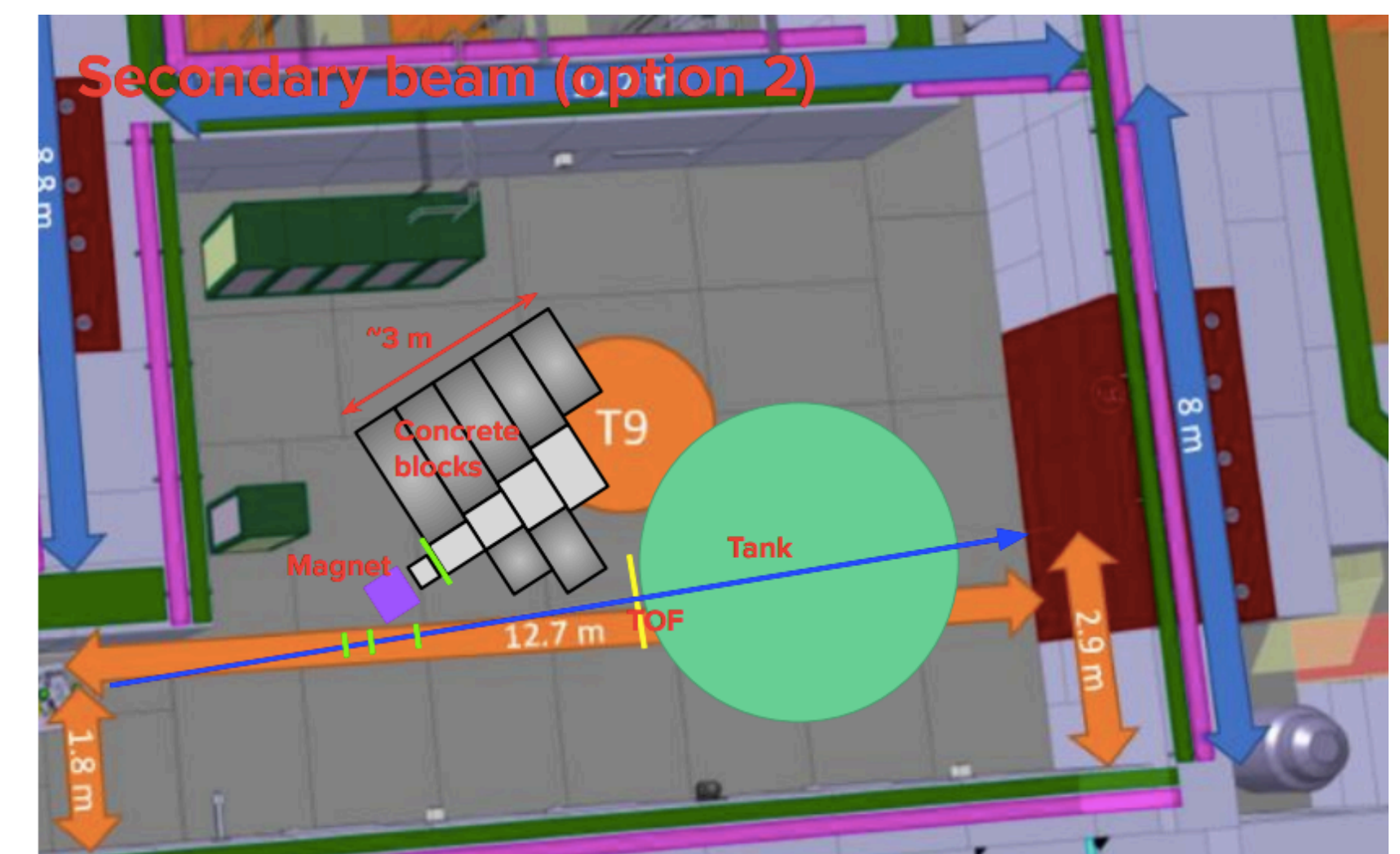
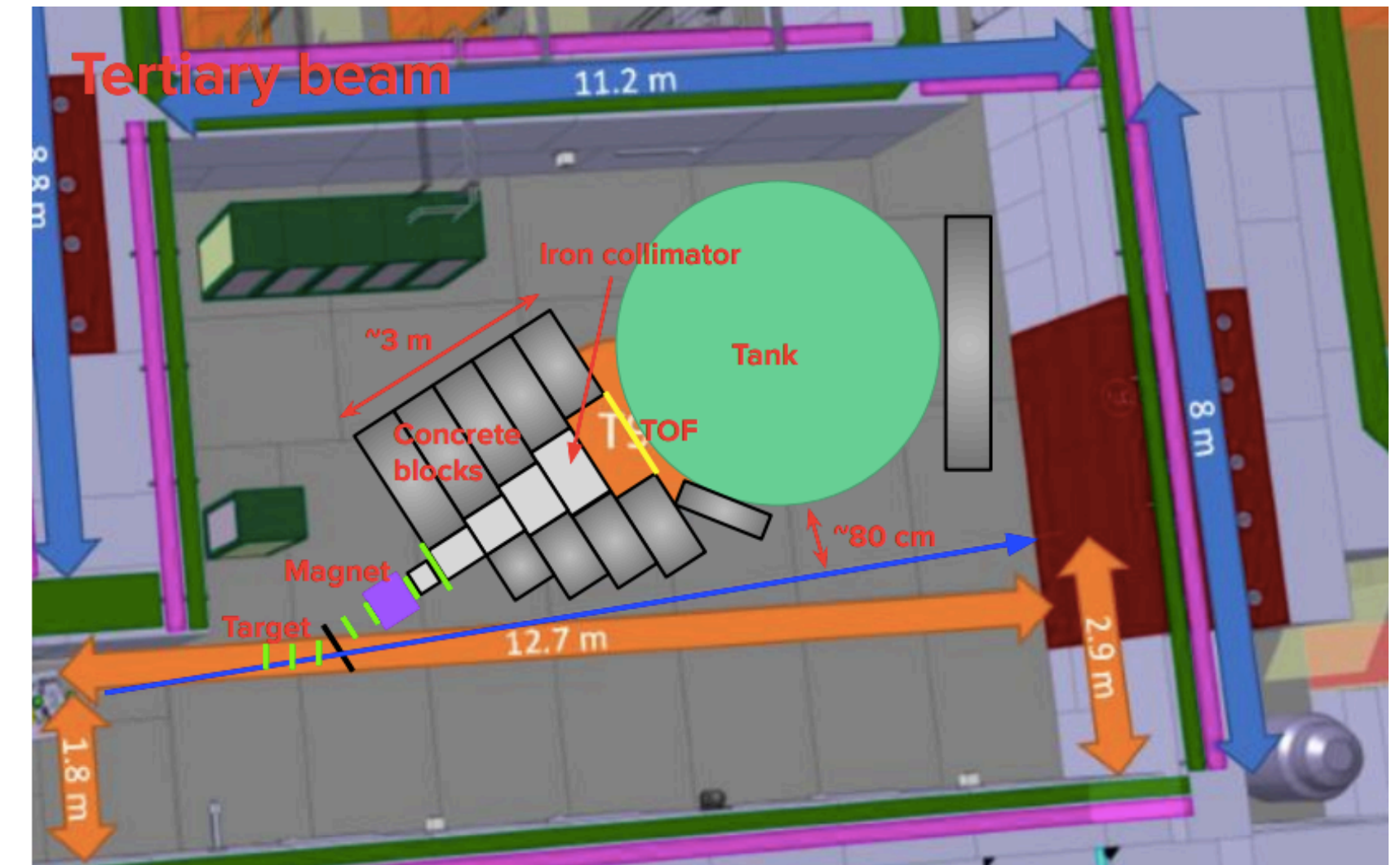

Low Momentum Secondary Beam

- At our December 2021 visit to CERN, we learned that low momentum operation for the T9 magnets below 200 MeV/c is possible
- This raised the question of whether low momentum particle fluxes in the secondary beam would be enough for WCTE
- If so, it would reduce the experimental complexity significantly and remove the need to move the detector
- Major concerns:
 - Are the non-electron components of the beam enough, particularly pions
 - Can we carry out particle identification, particularly between pions and muons well enough
 - Use combination of time-of-flight and aerogel Cherenkov threshold detectors (ACT)

Beam Test in March

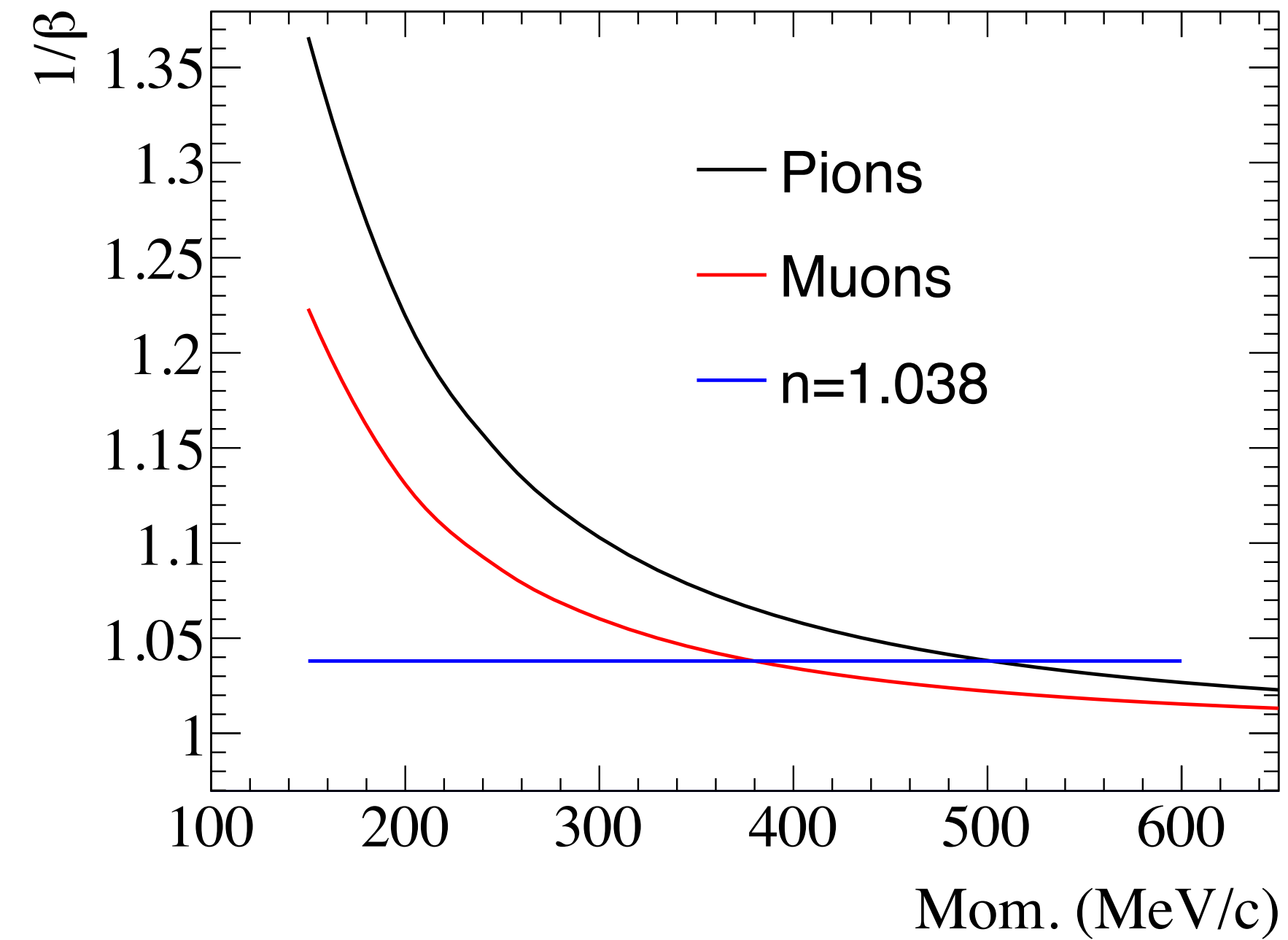

- We took low momentum data in the T9 beam line during the beam commissioning in March
- We used an ACT (above left) with $n=1.038$ to help study pion and muon fractions
 - Separation of pions and muons around 450 MeV/c (above right)
- We used the T9 scintillator detectors to measure TOF

Particle Identification Performance

- We study the ACT monitor signal vs. The TOF measurement
- We see a correlation between the two
 - Below threshold particles have a TOF that is consistent with pions, while above threshold are consistent with muons
- PID performance will need to be improved for WCTE operation
 - Thicker aerogel and multiple PMT readout for ACT
 - Better timing resolution for TOF

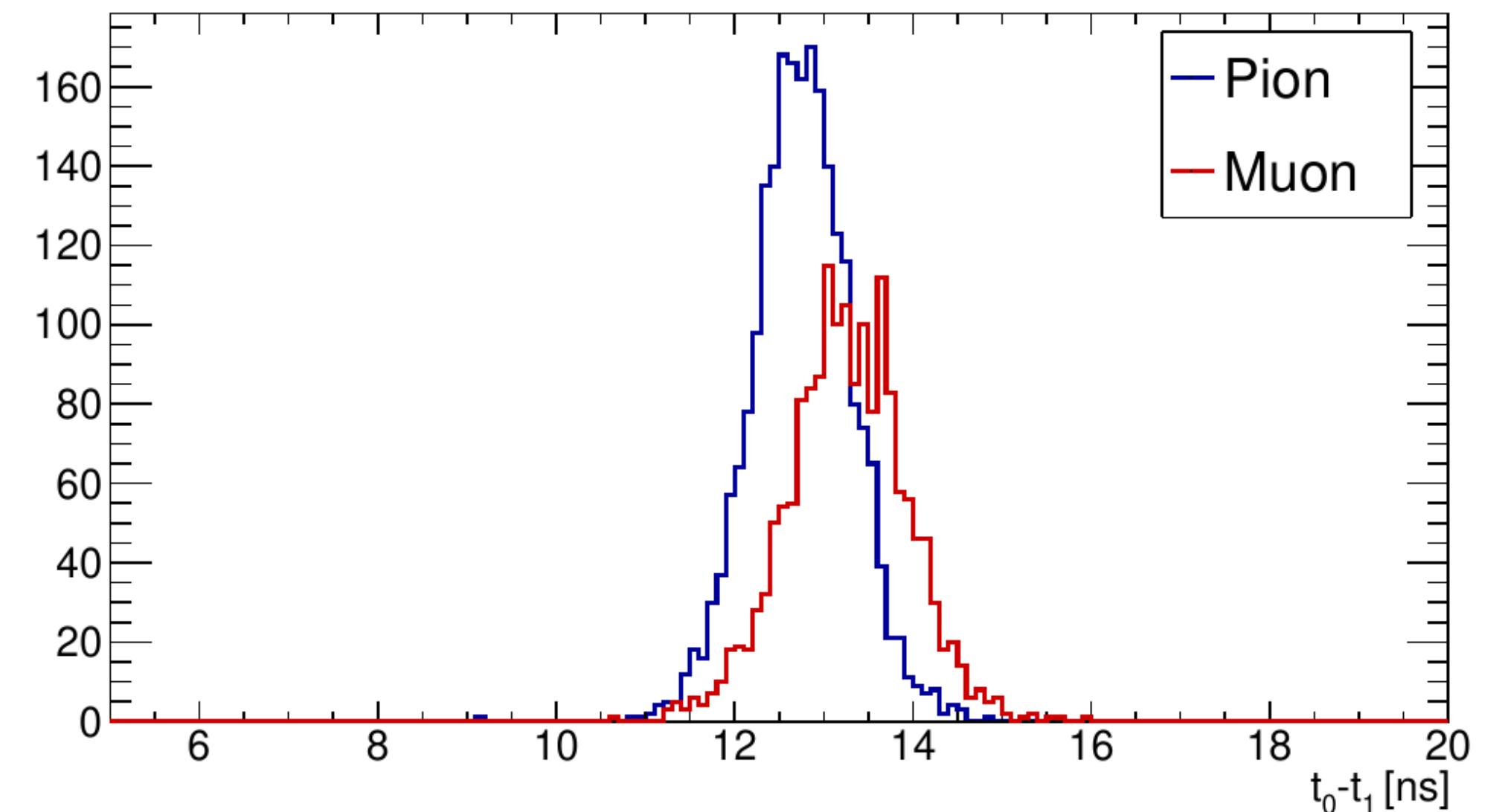
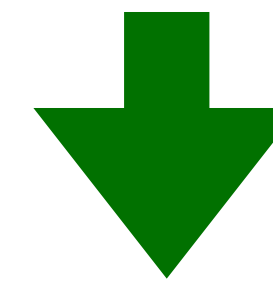
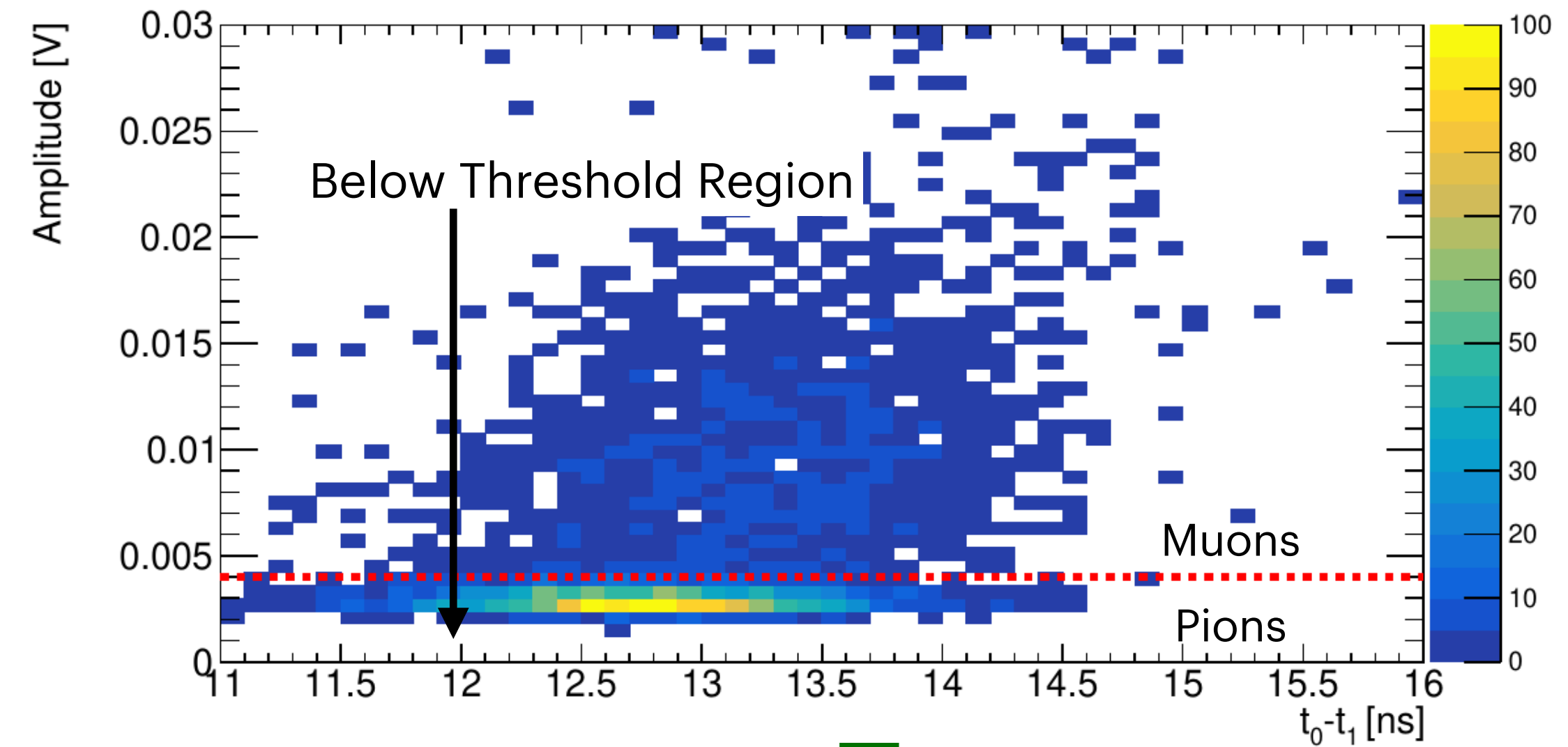

Beam Test Results

- Measured beam composition shows that electrons make up more than 99% of the beam below 450 MeV/c
- Simulation studies confirmed that there was too much material in the beam line for optimal low momentum operation in July
- This low momentum configuration is already designed into and available for the T9 beam line

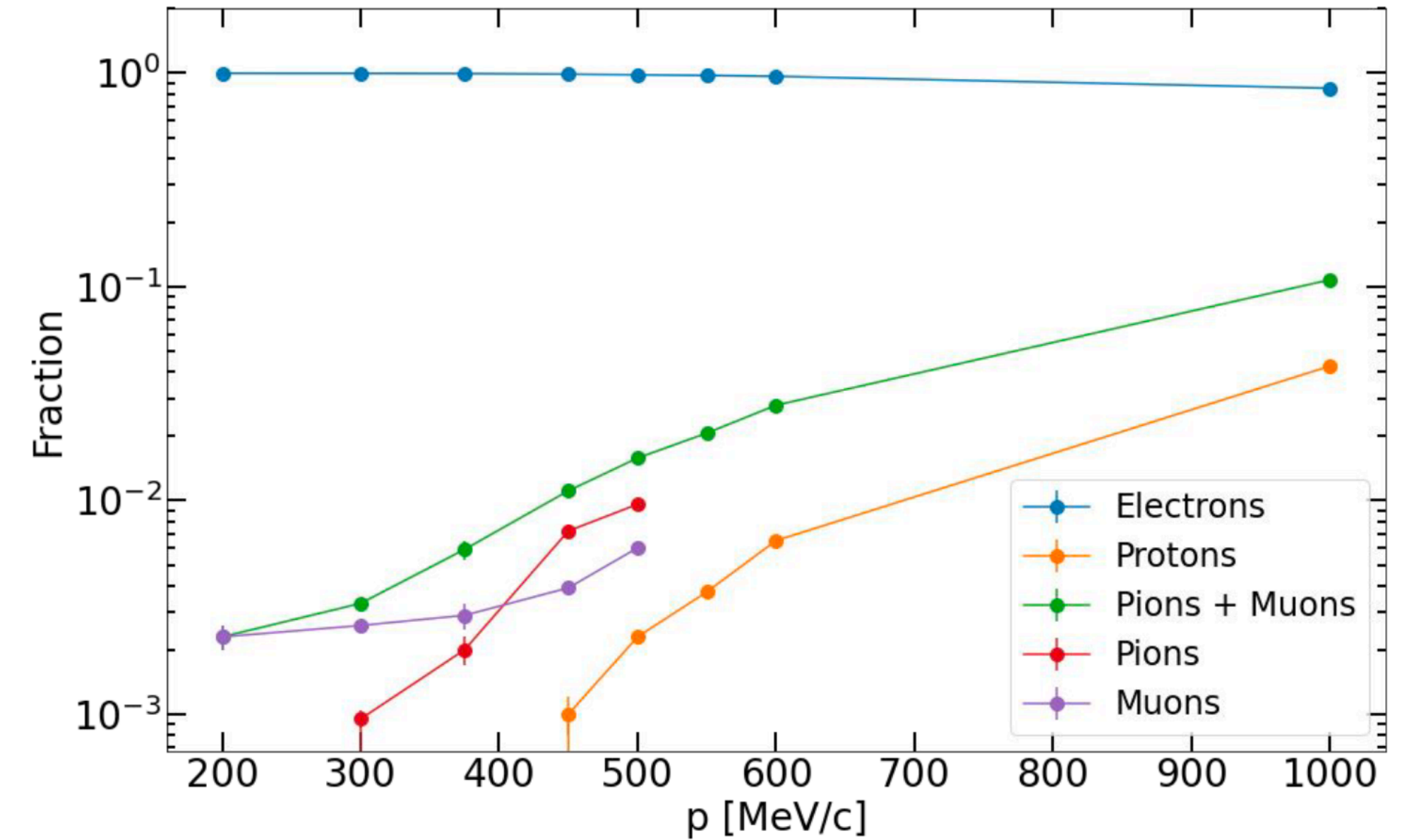

<https://edms.cern.ch/document/2370892>

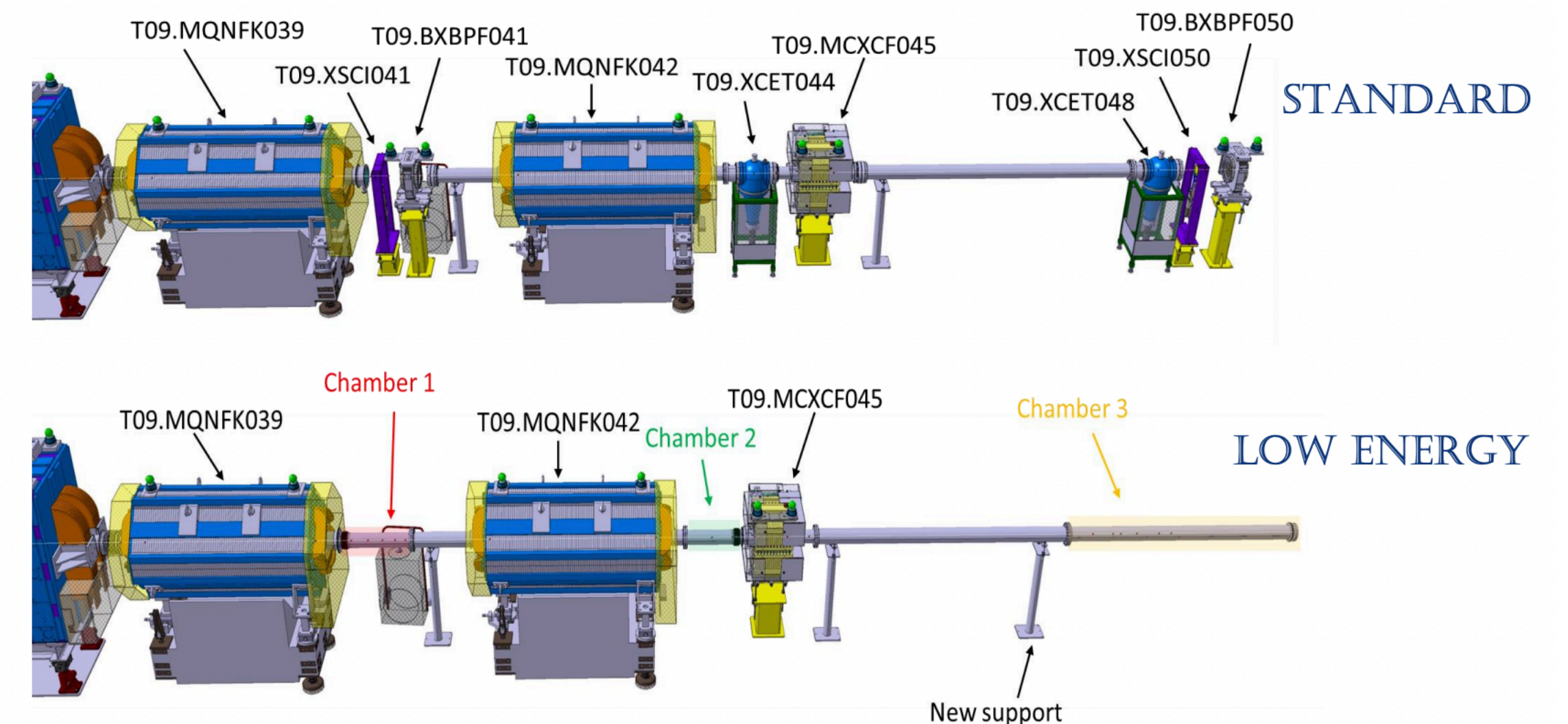

Environment & Safety

- We completed the Initial Safety Declaration and had the Launch Safety Discussion
- Safety contact for WCTE is Stefania Bordoni (University of Geneva)
- Outstanding issues that require further discussion
 - Disposal of the water after removal of the gadolinium sulfate leaving 0.14% sodium sulfate to be discussed with experts
 - Recapture of gas from the RPC time-of-flight detector to minimize the release of SF₆
- We are collecting the necessary information for the next stage of discussion on these topics
 - Working towards more detailed design of water system
 - Investigating the gas recovery capabilities in the East Hall

mPMT Update

- Functional electronics mainboard prototypes are produced and tested
- Progress to finalize design for pre-production prototype to be completed this summer
- Mechanical design is focused on methods of optical gel application applied before or after assembly
- Major delays encountered due to long lead times on procurement of components including electronics components and optical gel

Electronics main board

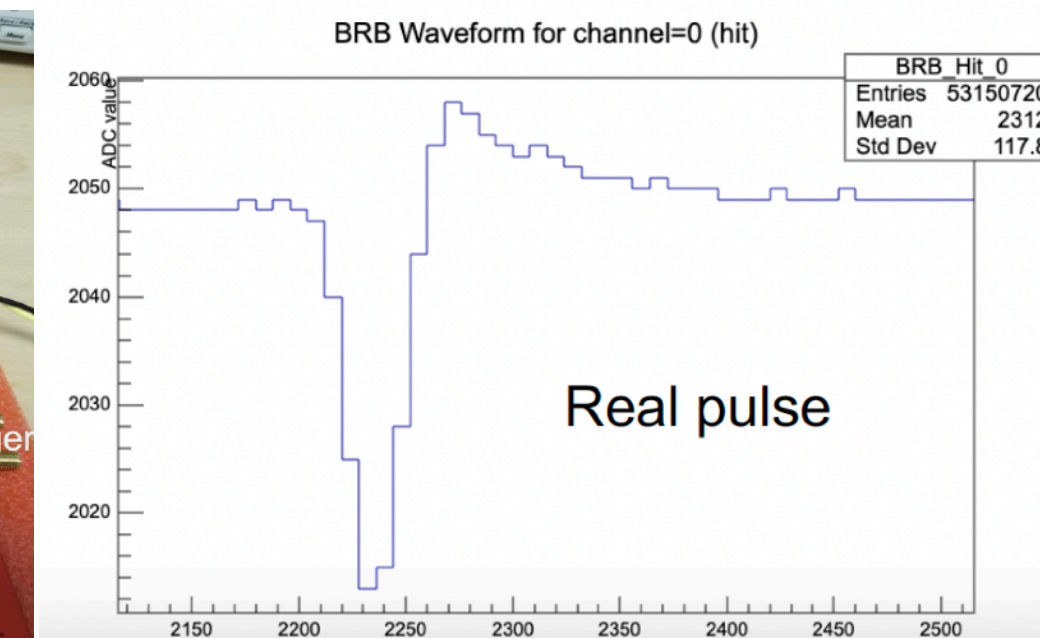
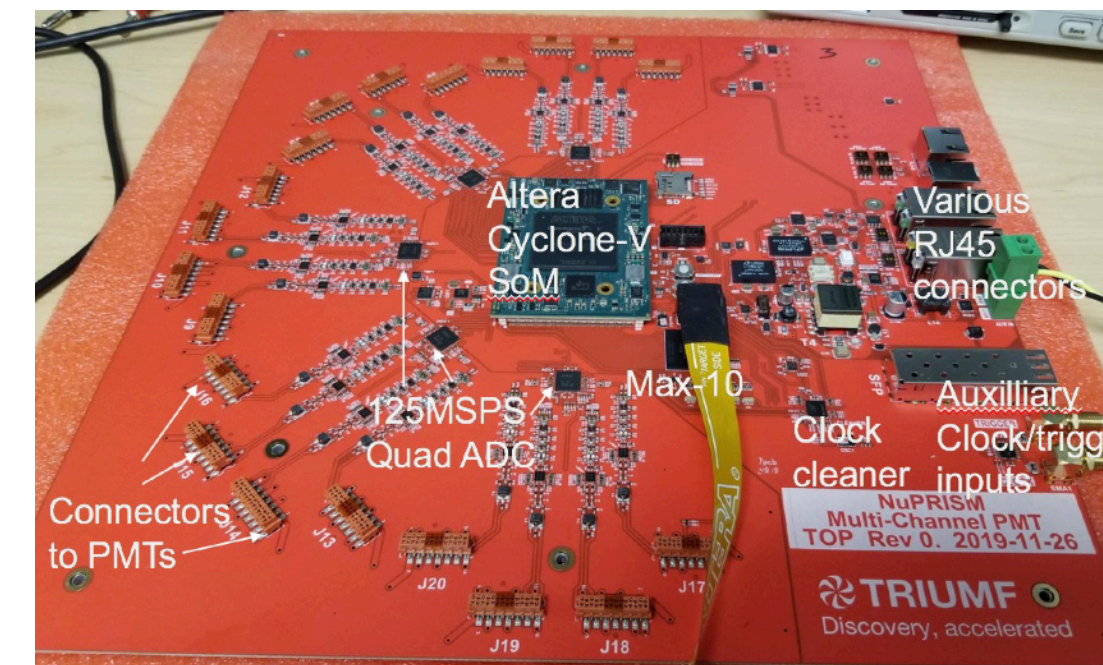

Ex-situ gel application prototype



In-situ gel application prototype



CDS Calibration System

- Prototype of the central deployment system (CDS) has been built and manufactured at Imperial college
- A light sealed unit has also been built and will be used to characterize and measure the uniformity of the laser diffuser ball
- Prototypes of the diffuser ball are currently being made
- A mock up of the shaft in the detector through which the calibration sources will be deployed has also been made to test the "drop of calibration sources into the detector"

Concept of CDS prototype in lab (x and z components shown)

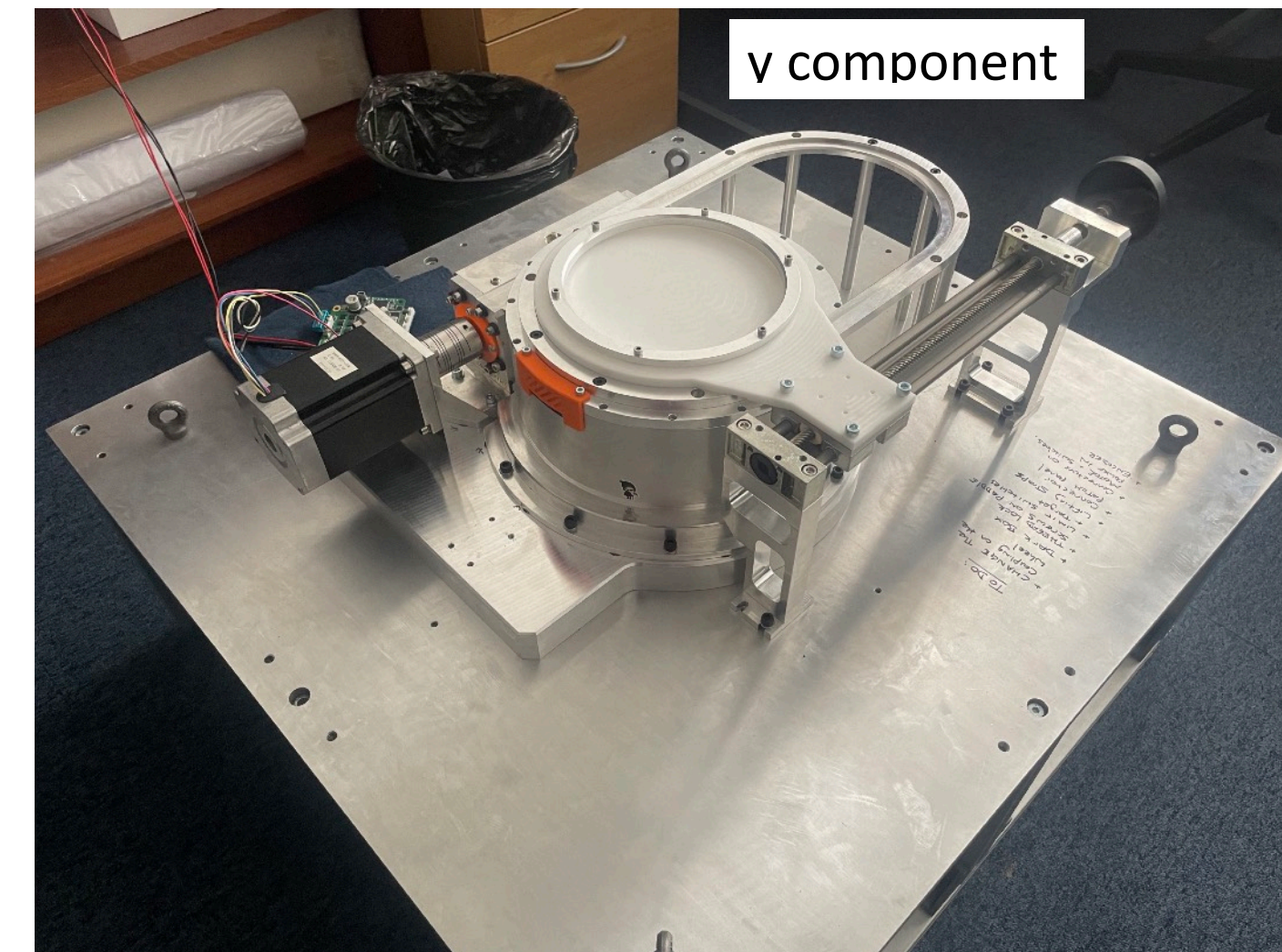
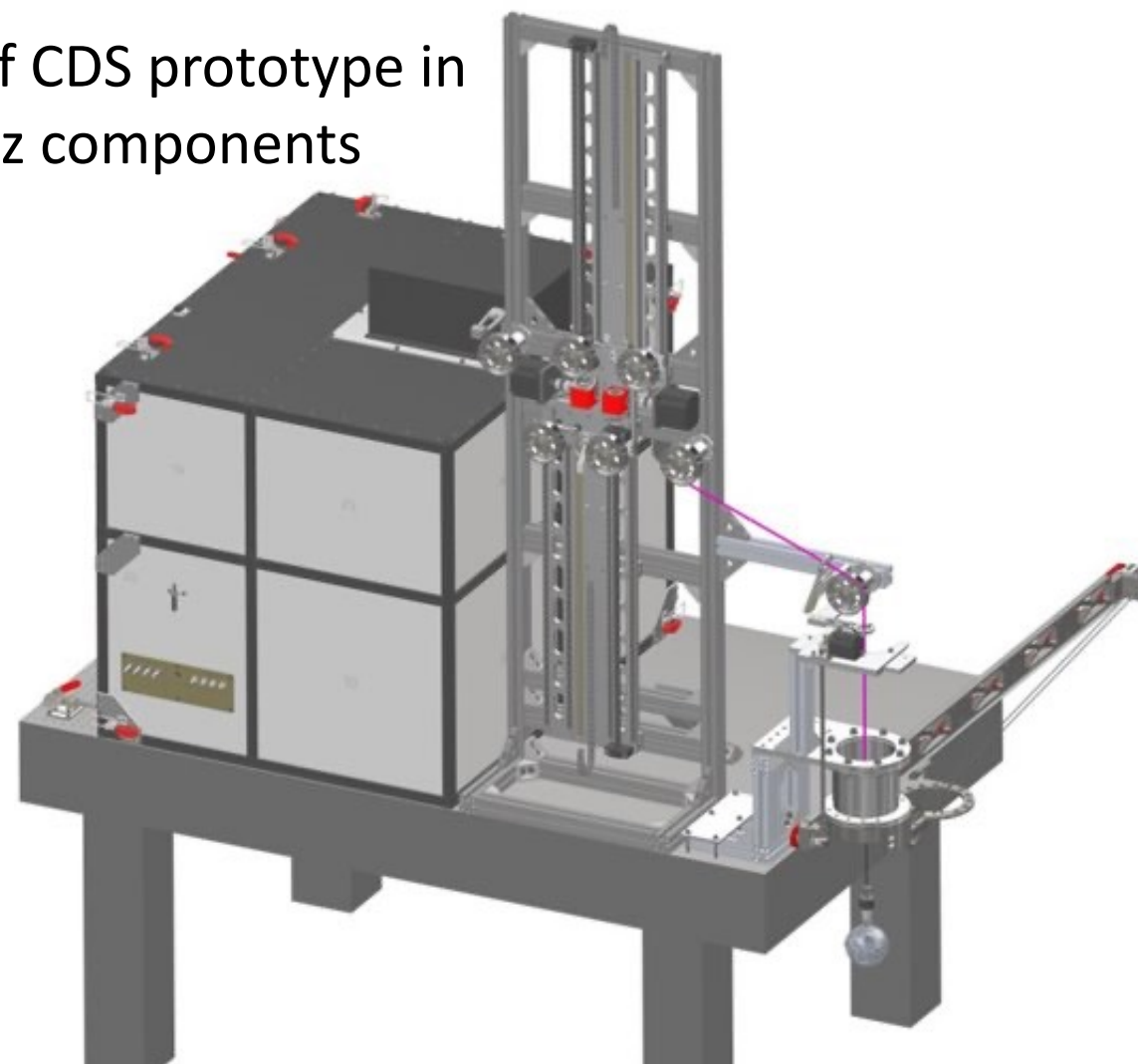

Prototype diffuser ball and preload mass (not yet filled with optical gel)



Radioactive Calibration Sources

Gamma source - Ni/Cf

- Goal is an isotropic source of gamma rays leading to single photon events for PMT calibration
- WCTE source, similar to previous SK design: 13.5 cm diameter, NiO + polyethylene mixed with epoxy; ^{252}Cf source held by brass rod in center of sphere
- ^{252}Cf decay provides neutrons: Thermal neutron capture on nickel: $^{58}\text{Ni}(n,\gamma)^{59}\text{Ni}$ (~9 MeV in gamma energy)
- Currently preparing materials for prototype sphere to understand construction process



Nickel source used in SuperK
(<https://arxiv.org/abs/1307.0162>)

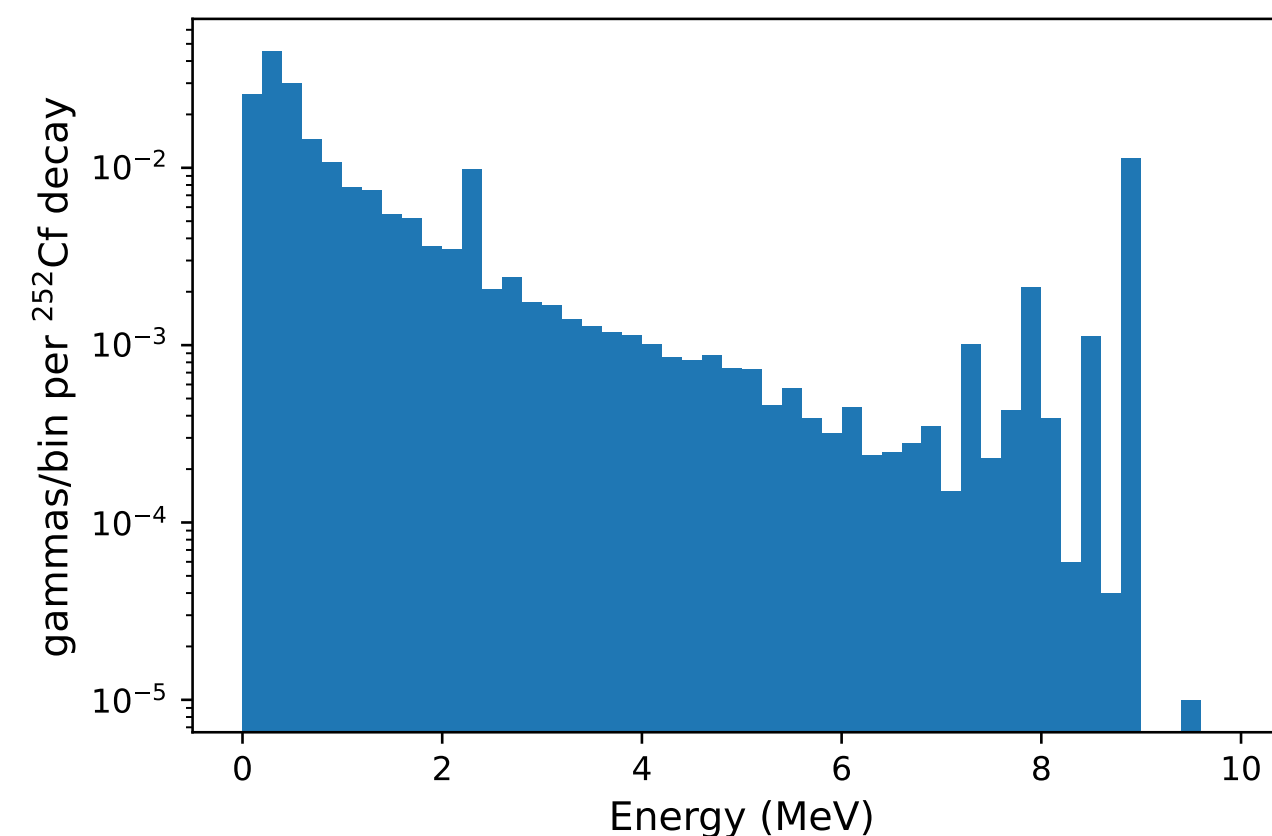

Gamma ray spectrum from simulated (Geant4) NiCf source with diameter 13.5 cm between 0 - 10 MeV

Neutron source - Am/Be

- In SK: acrylic case containing BGO scintillators surrounding an AmBe neutron source
- Tagging (~4.4 MeV gamma emitted in coincidence with a large fraction of neutrons) may be done by PMTs
- Currently considering a similar source for WCTE (potentially a cylindrical crystal with AmBe source embedded)

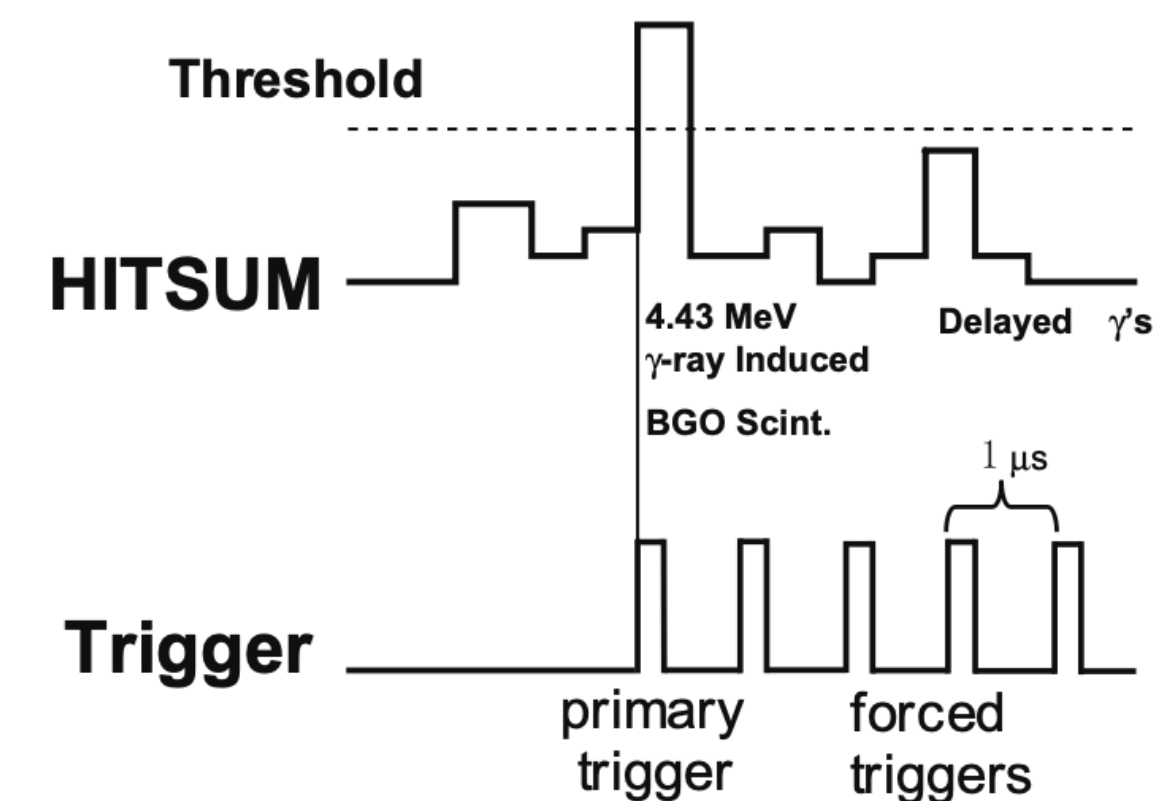

Tagging: trigger on sum of analog PMT signals within 200 ns, from H. Watanabe et al. *Astropart. Phys.* 31, 320 (2009).

Photogrammetry System

- Use standard cameras and lenses with custom-built underwater vessels for fixed cameras
- Ongoing tests at the UBC pool to characterize the optics under water
- Tests of the vessel at necessary pressures for Hyper-K detector are planned
- Prototype readout system has been developed and being tested
- Photogrammetry simulation of detectors under development - choose the best location of cameras in detectors

Prototype camera housing

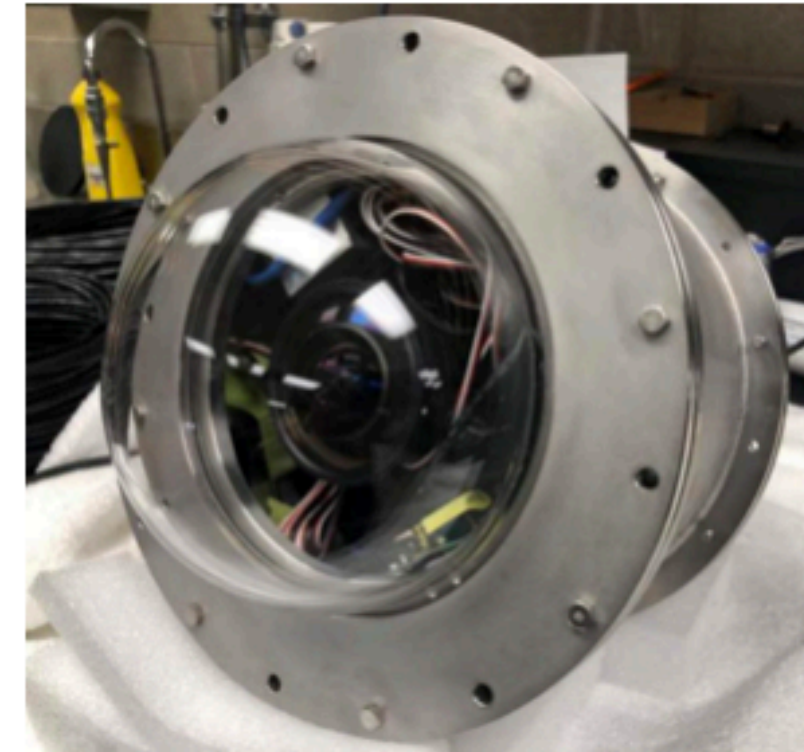

Measurements at UBC Pool



Camera readout (under development)

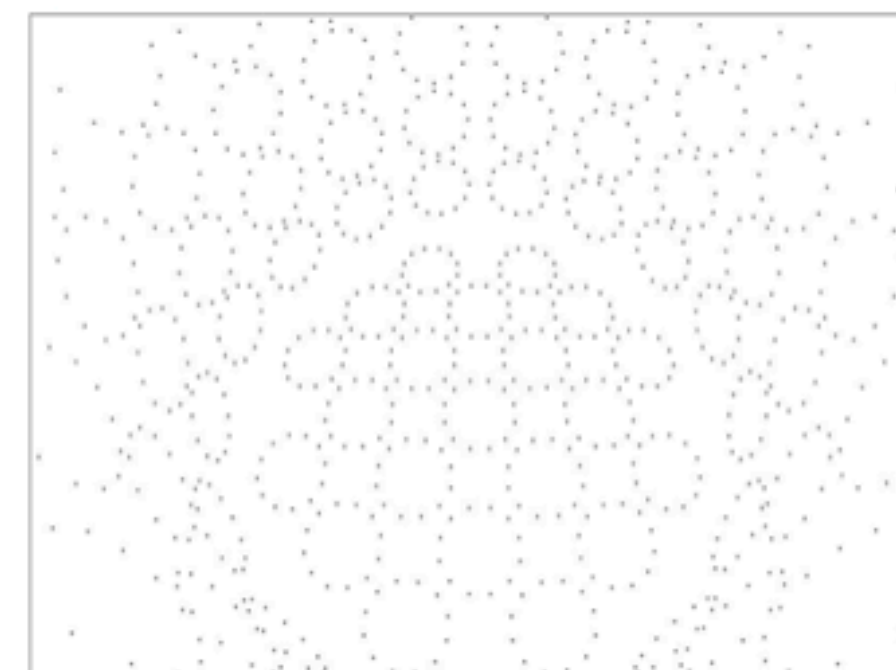
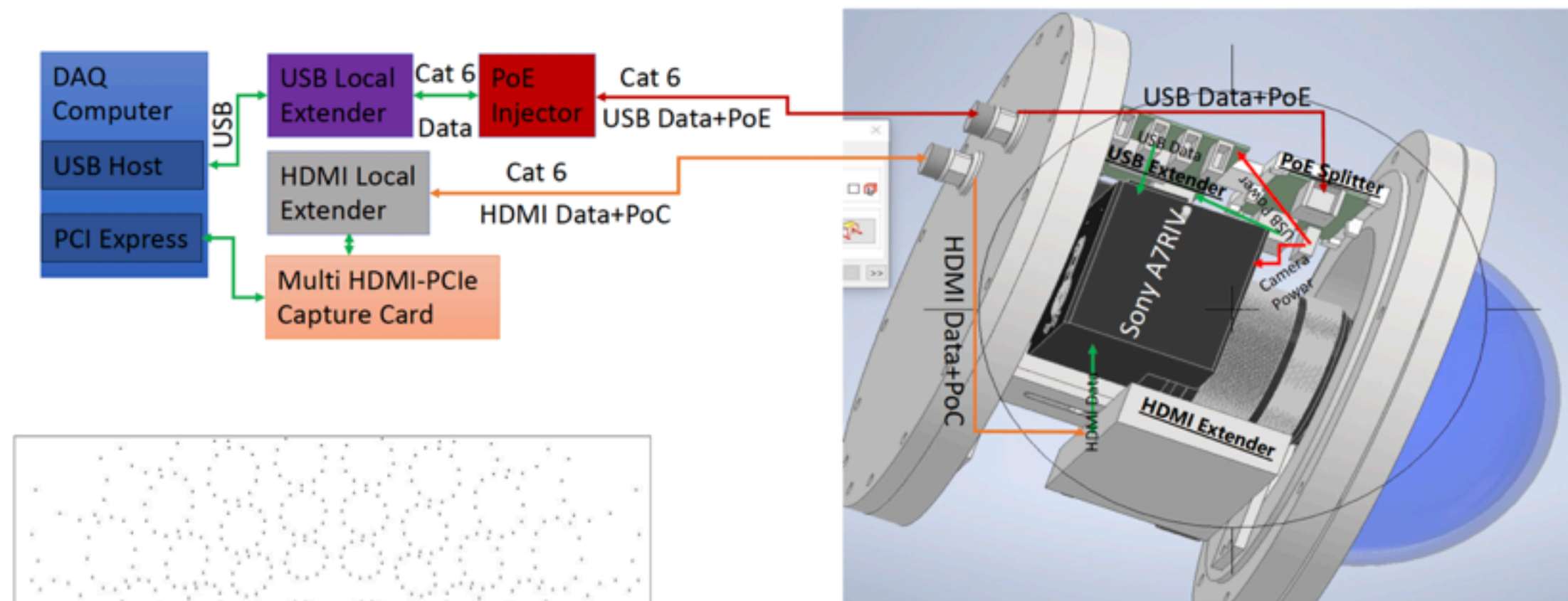

LED beacons from simulation