



# Recent highlights from LHCb



## Neville Harnew University of Oxford

On behalf of the LHCb Collaboration

Corfu Summer  
Institute  
31 August 2022

# Outline

- General introduction to LHCb
- An update of mixing and CP-violation measurements
  - Unitarity triangle and update on the angle  $\gamma$
  - Mixing and CP violation in charm
- New measurements in spectroscopy
- Rare decays and anomalies
  - Lepton universality
- The upgraded LHCb detector and outlook
- Summary

# LHCb forward spectrometer

- Forward-peaked production → LHCb is a forward spectrometer (operating in LHC collider mode)
  - $b\bar{b}$  cross-section =  $154.3 \pm 1.5 \pm 14.3 \mu\text{b}$  at  $\sqrt{s} = 13 \text{ TeV}$  in the LHCb acceptance  $2 < \eta < 5$  PRL 118,052002 (2017)
- $O(100,000)$   $b\bar{b}$  pairs produced/second at LHC Run 1&2 luminosities ( $c\bar{c}$  x20 larger)

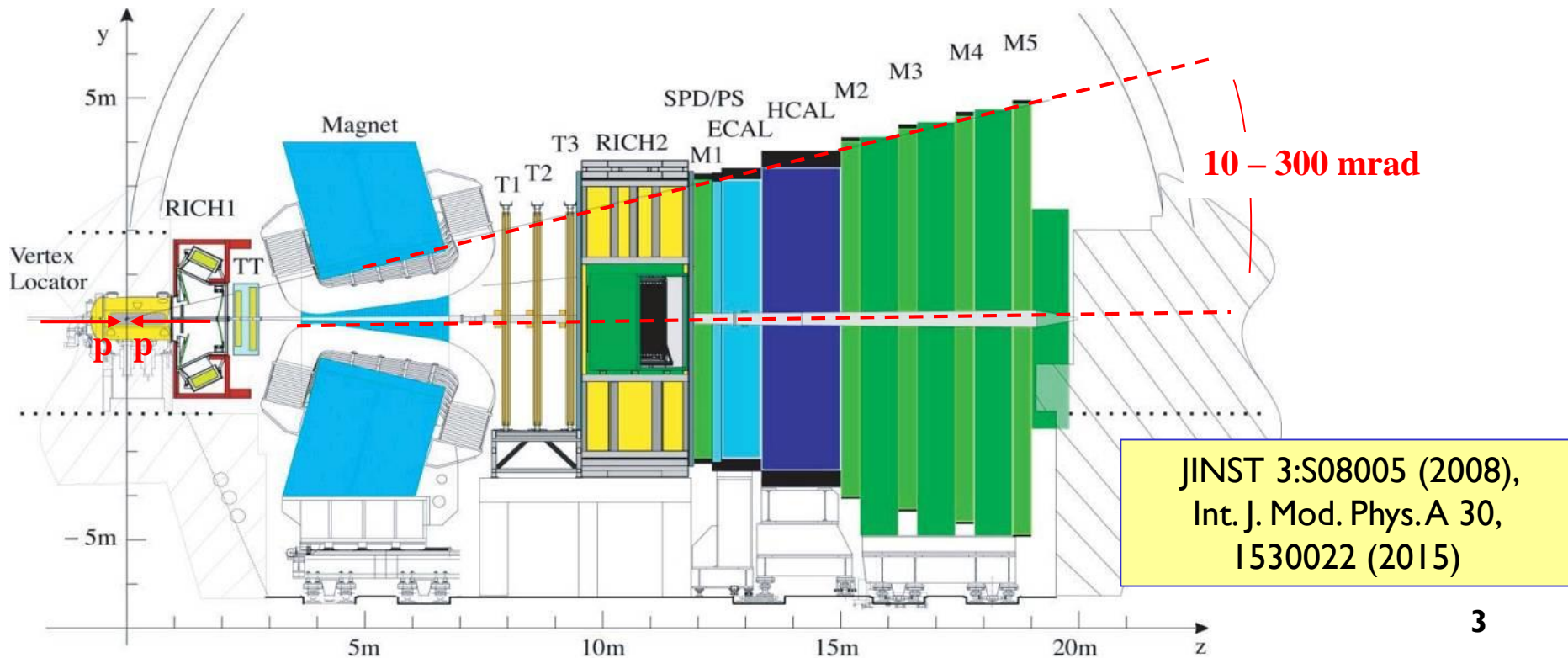
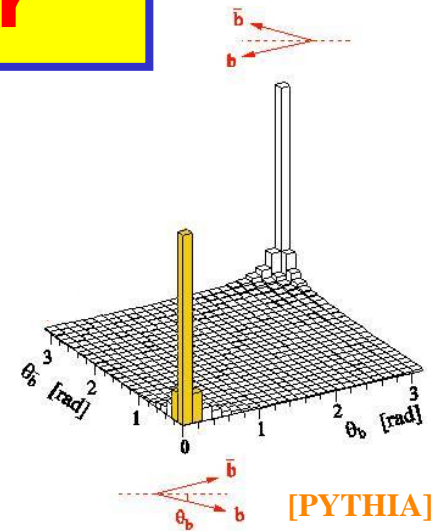

# LHCb data taking

- Design luminosity =  $2 \times 10^{32} \text{ cm}^{-2} \text{ s}^{-1}$  (50 times less than ATLAS/CMS). Typical running luminosity  $\sim 4 \times 10^{32} \text{ cm}^{-2} \text{ s}^{-1}$

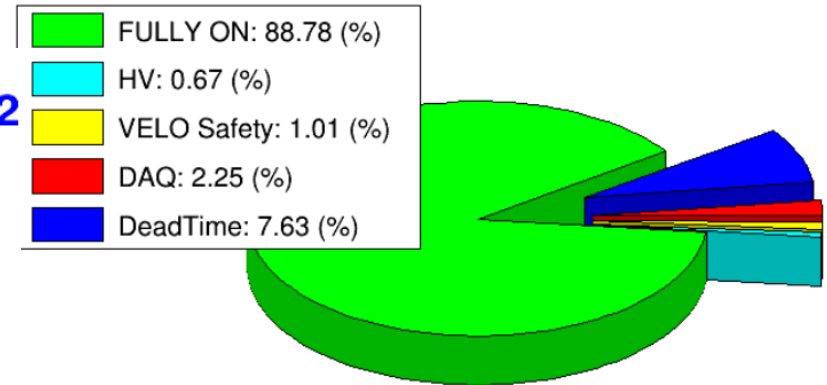
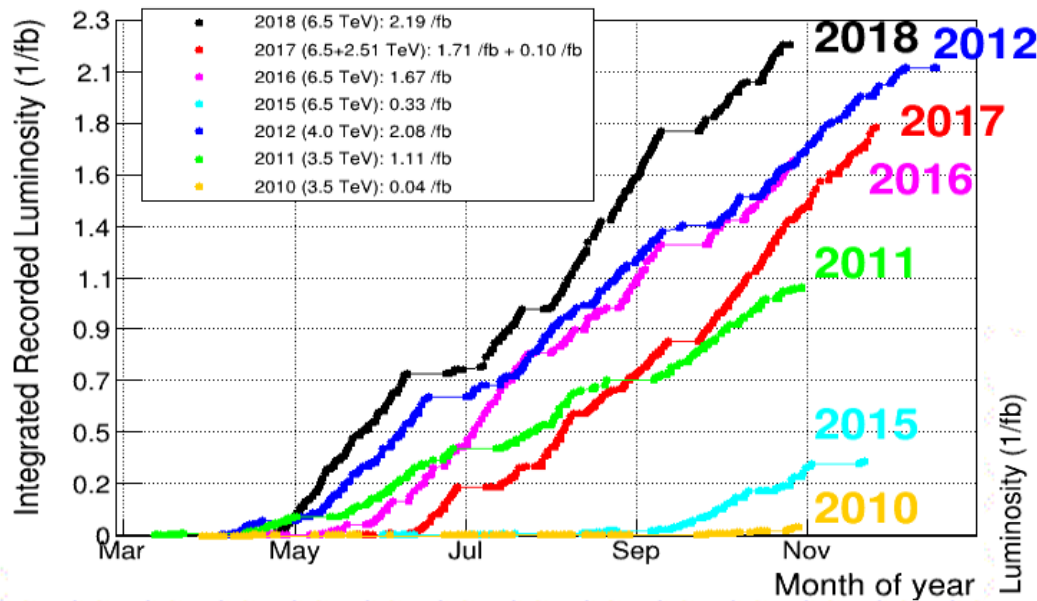

Run 1 & 2  
 $\mathcal{L}_{\text{int}} = 9 \text{ fb}^{-1}$

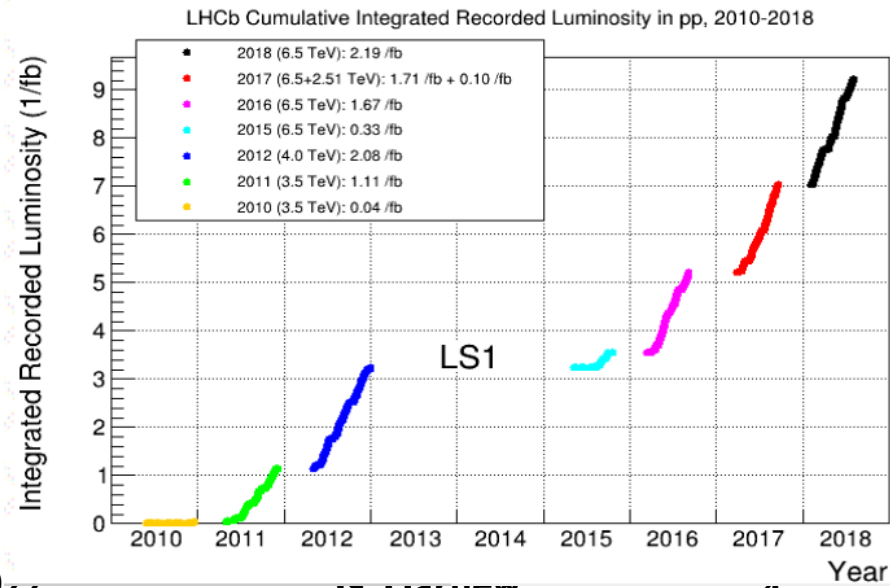

# **CP-violation and mixing in beauty and charm**



# Unitarity triangles

$$\begin{pmatrix} V_{ud} & V_{us} & V_{ub} \\ V_{cd} & V_{cs} & V_{cb} \\ V_{td} & V_{ts} & V_{tb} \end{pmatrix} = \begin{pmatrix} 1 - \lambda^2/2 & \lambda & A\lambda^3(\rho - i\eta) \\ -\lambda & 1 - \lambda^2/2 & A\lambda^2 \\ A\lambda^3(1 - \rho - i\eta) & -A\lambda^2 & 1 \end{pmatrix} + O(\lambda^4)$$

## Beauty system

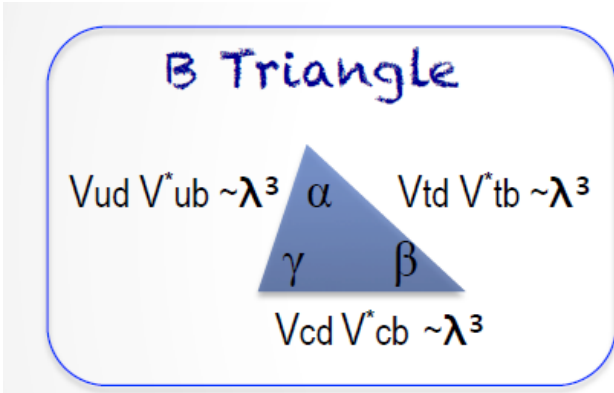

B system : angles  $\alpha, \beta, \gamma \sim 1$

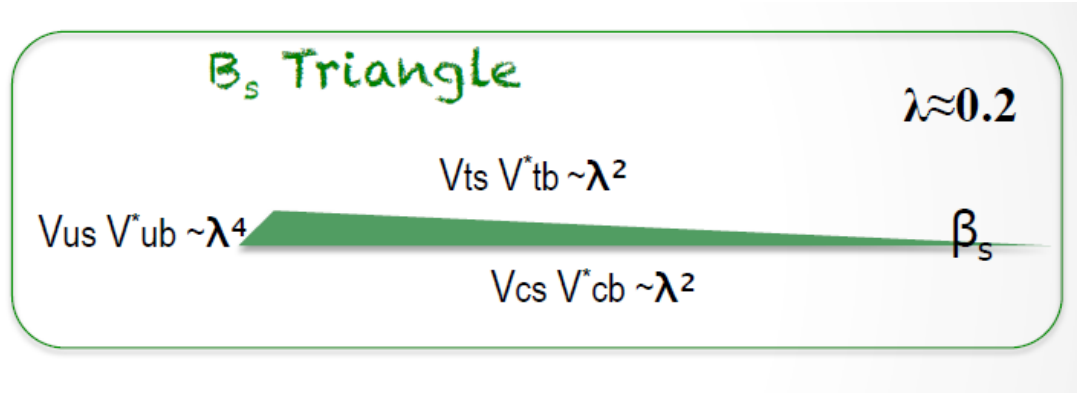

B<sub>s</sub> system : angle  $\beta_s \sim \lambda^2$

## Charm system

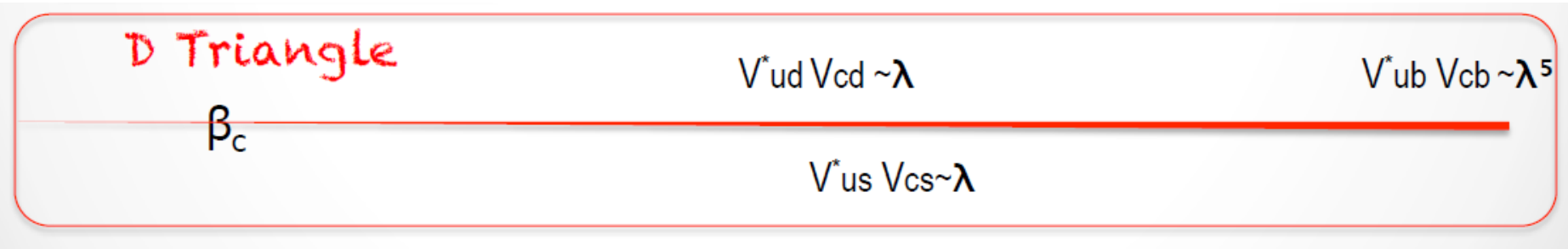

Charm system : angle  $\beta_c \sim \lambda^4$

Diagrams from Jolanta Brodzicka

# Unitarity Triangle measurements

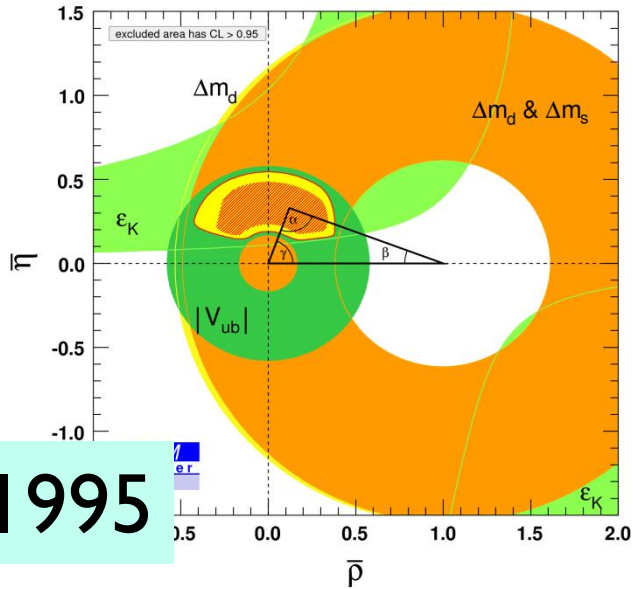

- Amazing progress in the last 27 years; the SM remains intact, but a whole lot still to learn

<http://ckmfitter.in2p3.fr>

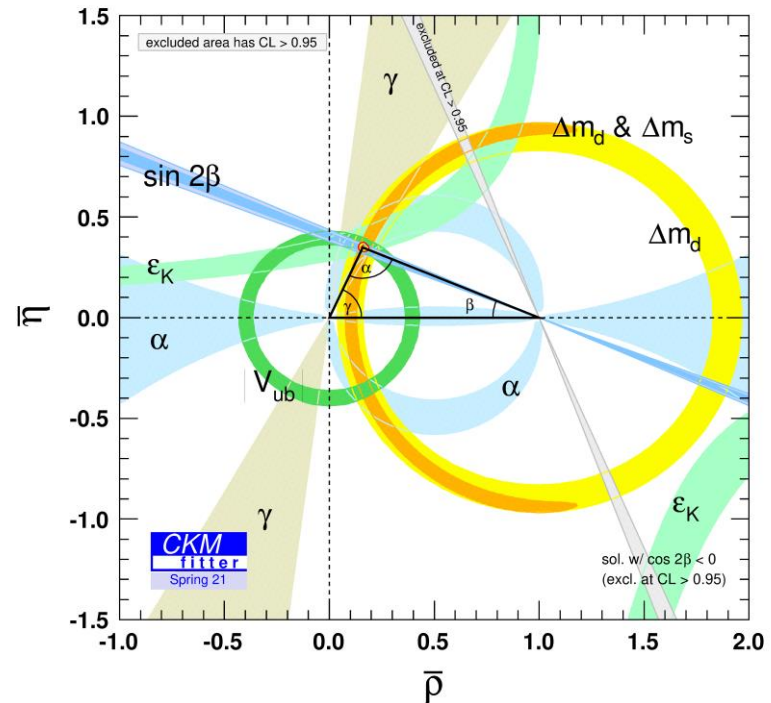
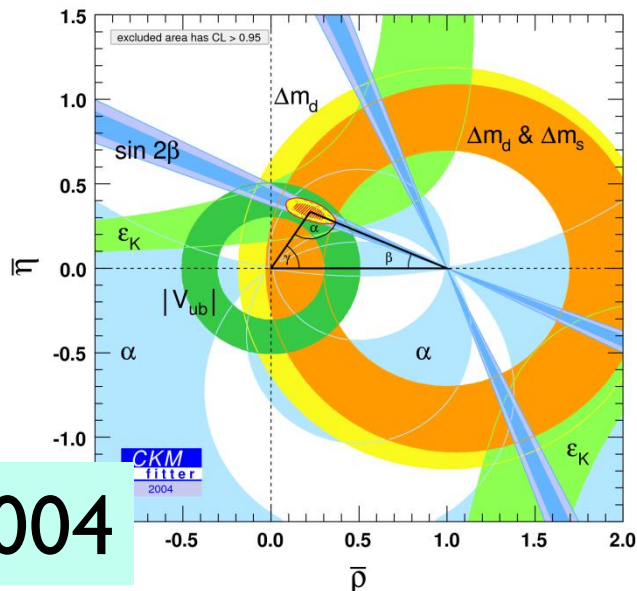

Now (dominated by LHCb)

# The angle $\gamma$ (a key measurement)

- Loop processes are very sensitive to the presence of New Physics
- Constraints on the triangle apex largely come from **loop** decay measurements
- Large uncertainty on  $\gamma$ , the only angle accessible at **tree** level : **forms a SM benchmark** (assuming no significant New Physics in tree decays)
- $\gamma$  prediction in SM theoretically very clean JHEP 01 (2014) 051, PRD 92(3):033002 (2015)
- Determination from CKM fit **excluding** all direct measurements of  $\gamma$ 

$$\gamma = (65.5^{+1.1}_{-2.7})^\circ$$
- Reaching degree level precision on  $\gamma$  is crucial

$$\gamma \equiv \arg \left[ -\frac{V_{ud}V_{ub}^*}{V_{cd}V_{cb}^*} \right]$$

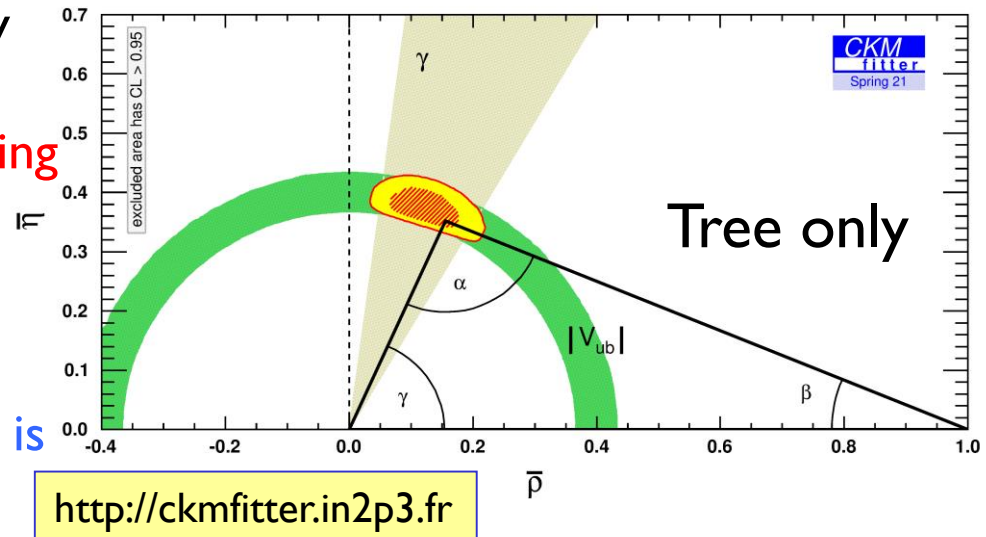
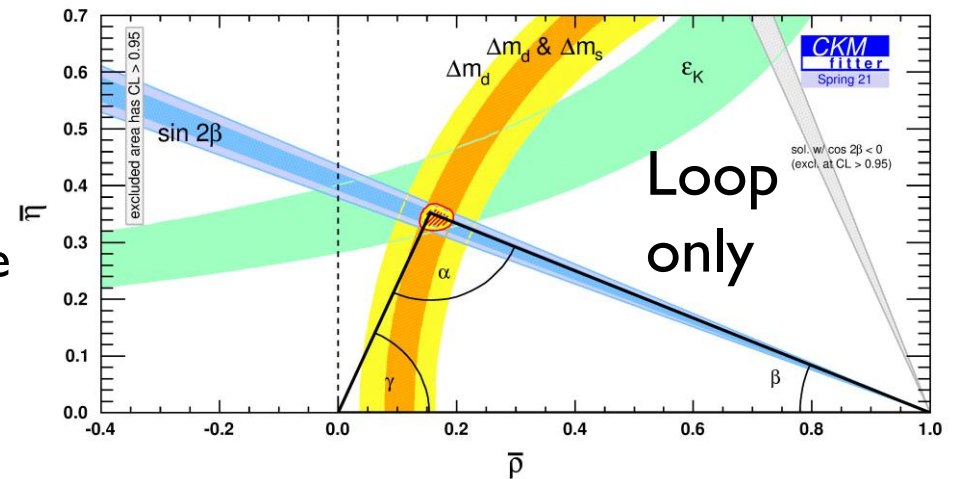



# The time-integrated mode: $B^- \rightarrow D^0 K^-$

$$\gamma \equiv \arg \left[ -\frac{V_{ud}V_{ub}^*}{V_{cd}V_{cb}^*} \right]$$

(and charge conjugate mode  $B^+ \rightarrow \bar{D}^0 K^+$ )  
provides most precise measurement of  $\gamma$

- Interference possible if  $D^0$  and  $\bar{D}^0$  decay to **same** final state
- Two possible decay paths to final state via  $D^0$  and  $\bar{D}^0$

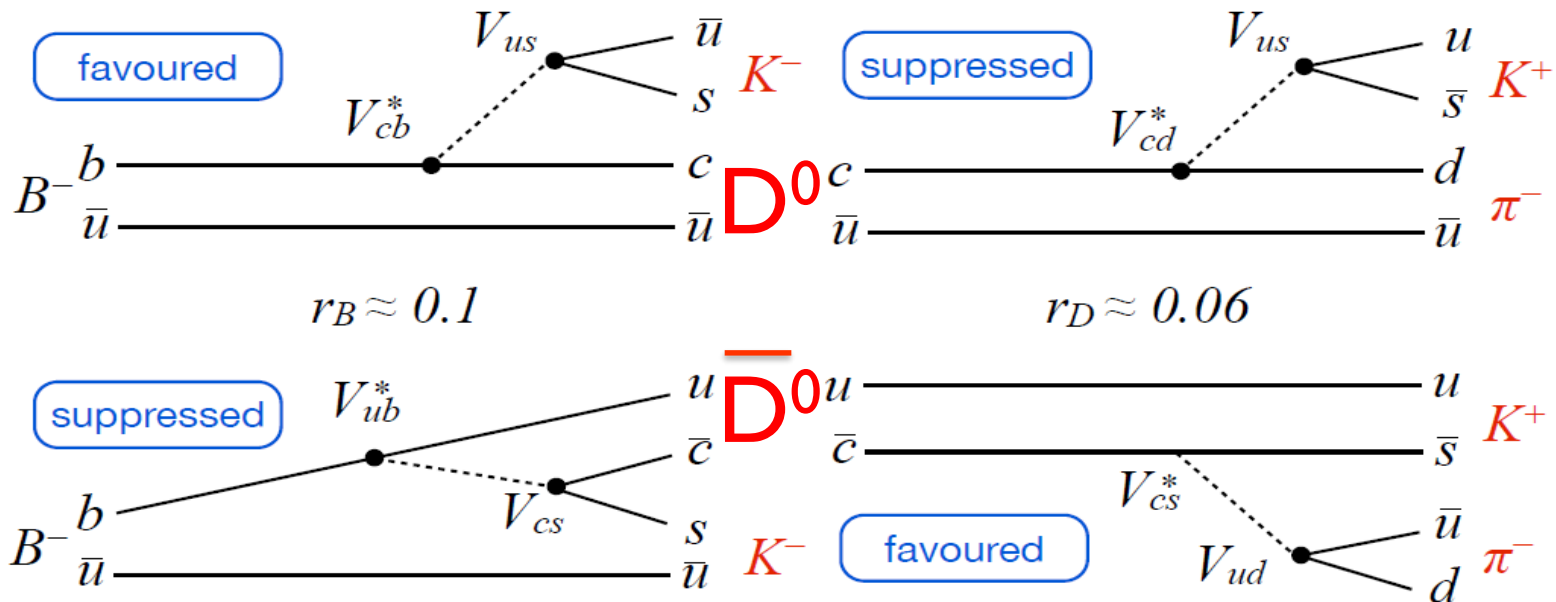

- Branching fraction for favoured B decay only  $\sim 10^{-4}$ 
  - Measurements require high statistics

# New : $\gamma$ from $B^\pm \rightarrow D [K^-\pi^+\pi^+\pi^-] h^\pm$ decays

- Large benefits from binned analysis
- Measure observables in 4 bins of D decay phase space arXiv: 1909.10196
- Use full Run 1 and Run 2 dataset
- Largest CP violation observed

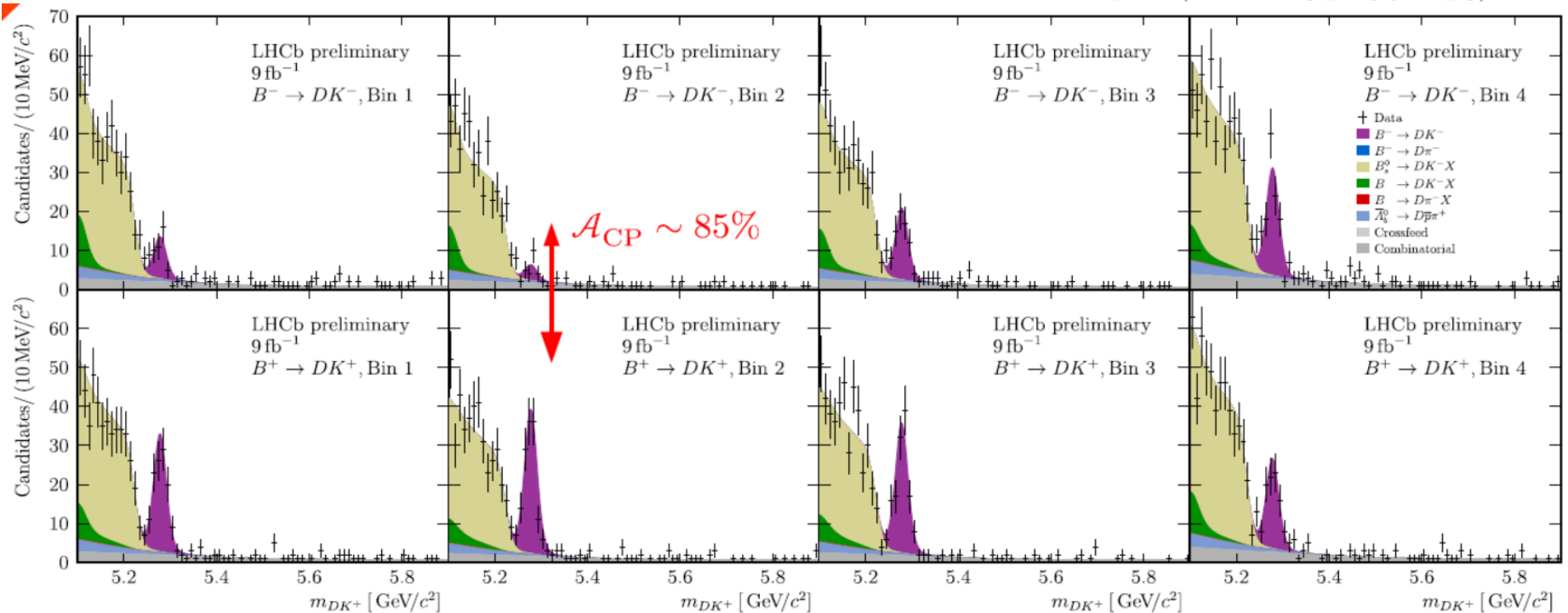
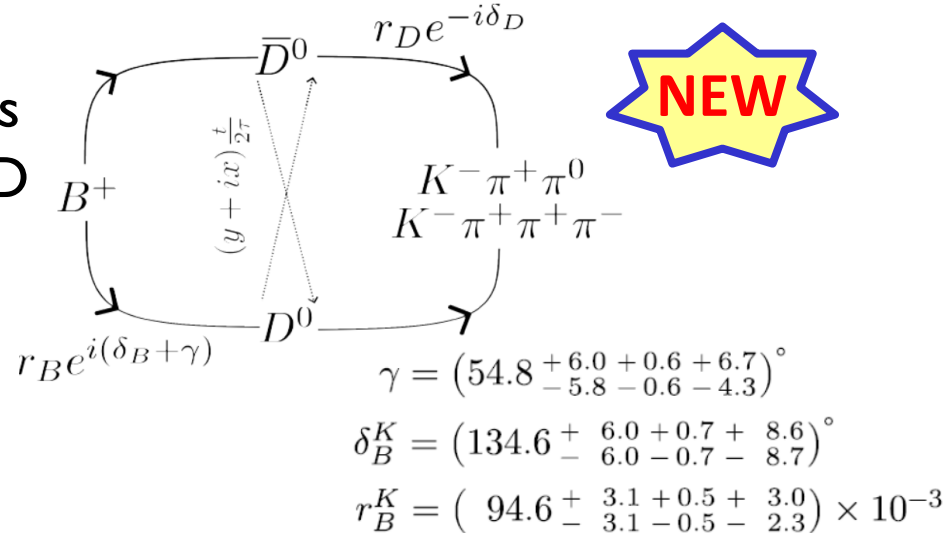

# New : $\gamma$ from $B^\pm \rightarrow D [h^\pm h' \mp \pi^0] h^\pm$ decays

arXiv:2112.10617

**NEW**

- $\pi^0$  reconstruction is challenging at LHCb
- Measure observables in 3 D decay channels

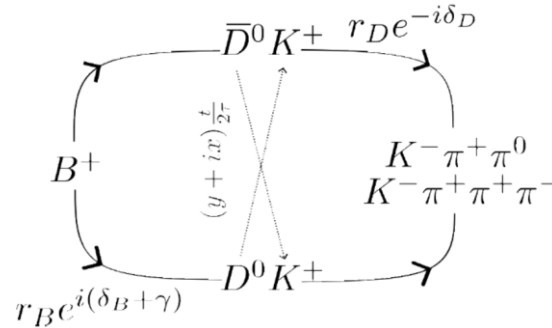

$$\begin{aligned} \gamma &= (56^{+24}_{-19})^\circ, \\ \delta_B &= (122^{+19}_{-23})^\circ, \\ r_B &= (9.3^{+1.0}_{-0.9}) \times 10^{-2} \end{aligned}$$

- $D \rightarrow K^\pm \pi^\mp \pi^0$
- $D \rightarrow \pi^+ \pi^- \pi^0$
- $D \rightarrow K^+ K^- \pi^0$

and two B decays

$B^+ \rightarrow DK^+$  &  $B^+ \rightarrow D\pi^+$

- Gives total of 11 CP violating observables
- Use full Run 1 and Run 2 dataset

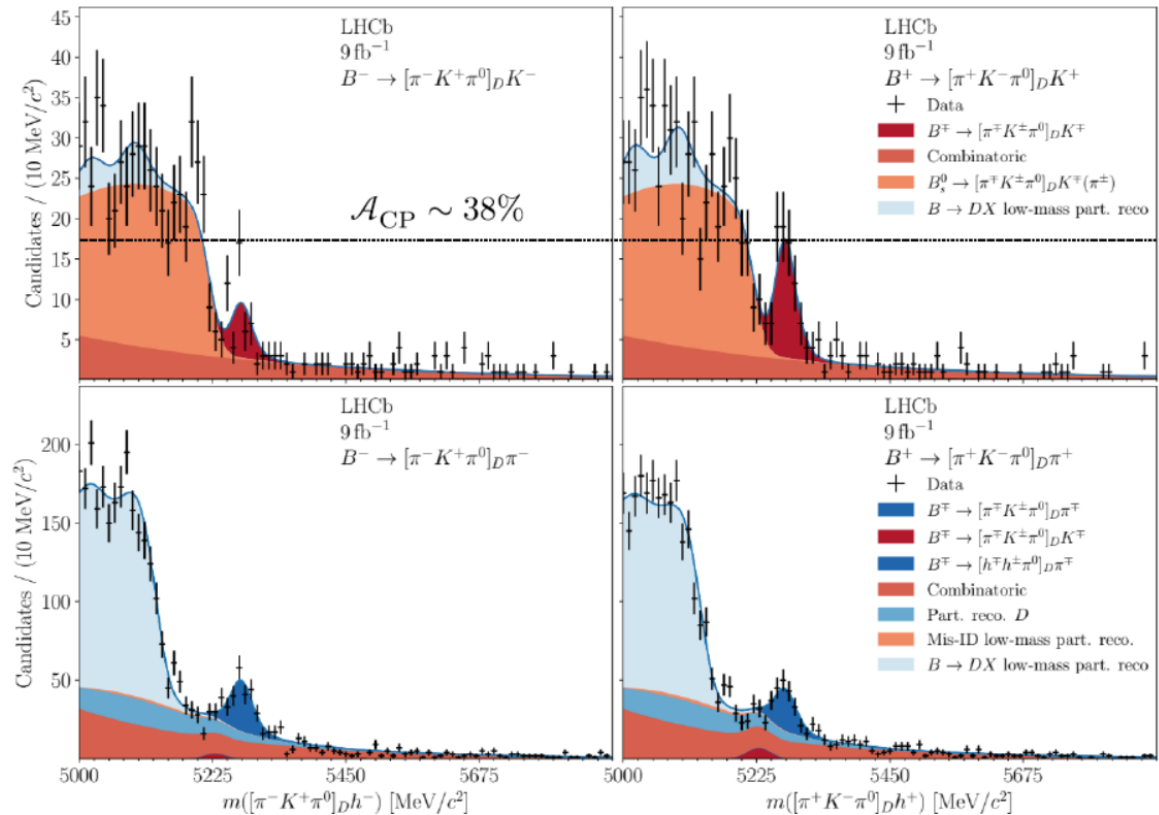

# LHCb combination from different modes

JHEP 12 (2021) 141

- The most recent combination includes many decay modes :

<i>B</i> decay	<i>D</i> decay	Data set
$B^\pm \rightarrow Dh^\pm$	$D \rightarrow h^+h^-$	Run 1&2
$B^\pm \rightarrow Dh^\pm$	$D \rightarrow h^+\pi^-\pi^-\pi^+$	Run 1
$B^\pm \rightarrow Dh^\pm$	$D \rightarrow h^+h^-\pi^0$	Run 1
$B^\pm \rightarrow Dh^\pm$	$D \rightarrow K_S^0h^+h^-$	Run 1&2
$B^\pm \rightarrow Dh^\pm$	$D \rightarrow K_S^0K^\pm\pi^\mp$	Run 1&2
$B^\pm \rightarrow DK^{*\pm}$	$D \rightarrow h^+h^-$	Run 1&15/16
$B^\pm \rightarrow DK^{*\pm}$	$D \rightarrow h^+\pi^-\pi^-\pi^+$	Run 1&15/16
$B^\pm \rightarrow Dh^\pm\pi^+\pi^-$	$D \rightarrow h^+\pi^-\pi^-\pi^+$	Run 1
$B^0 \rightarrow DK^{*0}$	$D \rightarrow h^+h^-$	Run 1&15/16
$B^0 \rightarrow DK^{*0}$	$D \rightarrow h^+\pi^-\pi^-\pi^+$	Run 1&15/16
$B^0 \rightarrow DK^{*0}$	$D \rightarrow K_S^0h^+h^-$	Run 1
$B^0 \rightarrow D^\mp\pi^\pm$	$D^+ \rightarrow K^-\pi^+\pi^+$	Run 1
$B_s^0 \rightarrow D_s^\mp K^\pm$	$D_s^+ \rightarrow h^+h^-\pi^+$	Run 1
$B_s^0 \rightarrow D_s^\mp K^\pm\pi^+\pi^-$	$D_s^+ \rightarrow h^+h^-\pi^+$	Run 1&2
<i>D</i> decay	Observable(s)	Data set
$D^0 \rightarrow h^+h^-$	$\Delta A_{CP}$	Run 1&2
$D^0 \rightarrow h^+h^-$	$y_{CP}$	Run 1
$D^0 \rightarrow h^+h^-$	$\Delta Y$	Run 1&2
$D^0 \rightarrow K^+\pi^-$ (Single Tag)	$R^\pm, (x'^\pm)^2, y'^\pm$	Run 1
$D^0 \rightarrow K^+\pi^-$ (Double Tag)	$R^\pm, (x'^\pm)^2, y'^\pm$	Run 1&15/16
$D^0 \rightarrow K^\pm\pi^\mp\pi^+\pi^-$	$(x^2 + y^2)/4$	Run 1
$D^0 \rightarrow K_S^0\pi^+\pi^-$	$x, y$	Run 1
$D^0 \rightarrow K_S^0\pi^+\pi^-$	$x_{CP}, y_{CP}, \Delta x, \Delta y$	Run 1&2

# LHCb combination from the different modes

LHCb average

$$\gamma = (65.4^{+3.8}_{-4.2})^\circ$$

JHEP 12 (2021) 141

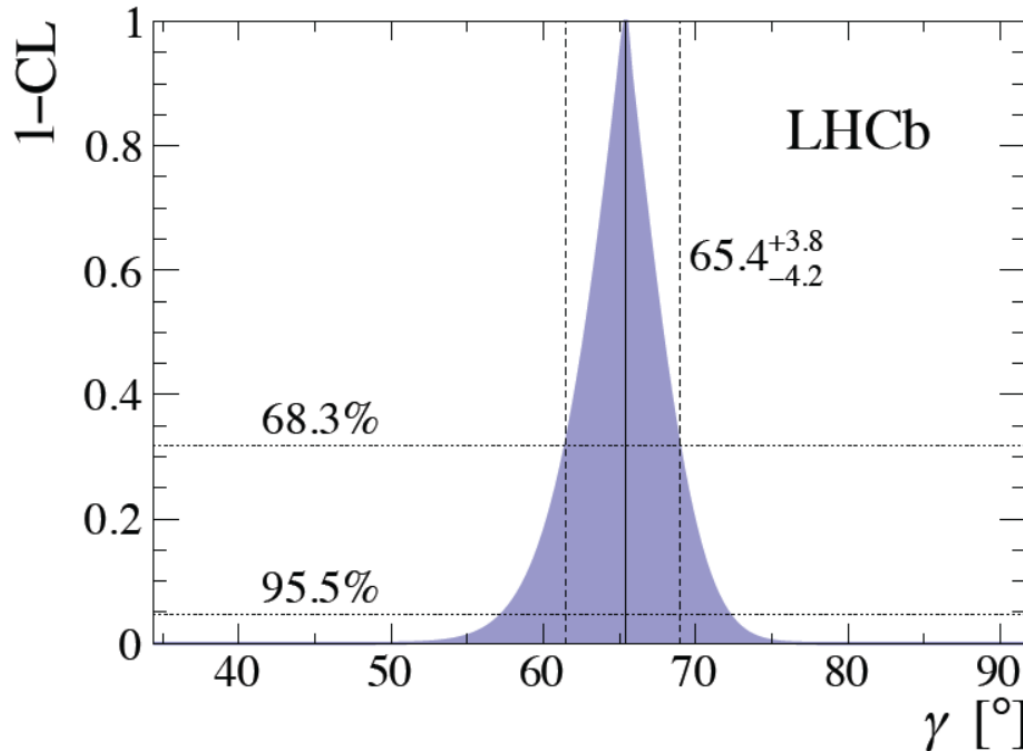

LHCb dominates world average

Reminder of indirect constraint, mainly from loops

$$\gamma = (65.5^{+1.1}_{-2.7})^\circ$$

BaBar :  $\gamma = (69^{+17}_{-16})^\circ$

PRD 87 (2013) 052015

Belle:  $\gamma = (73^{+15}_{-14})^\circ$

arXiv:1301.2033



# Breakdowns and evolution of $\gamma$ results

JHEP 12 (2021) 141

$$\gamma = (65.4^{+3.8}_{-4.2})^\circ$$

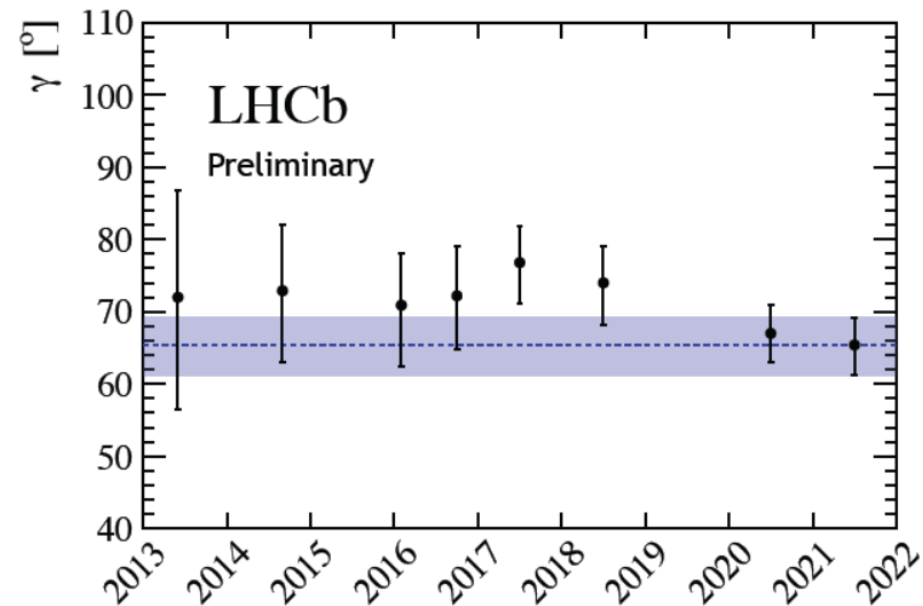
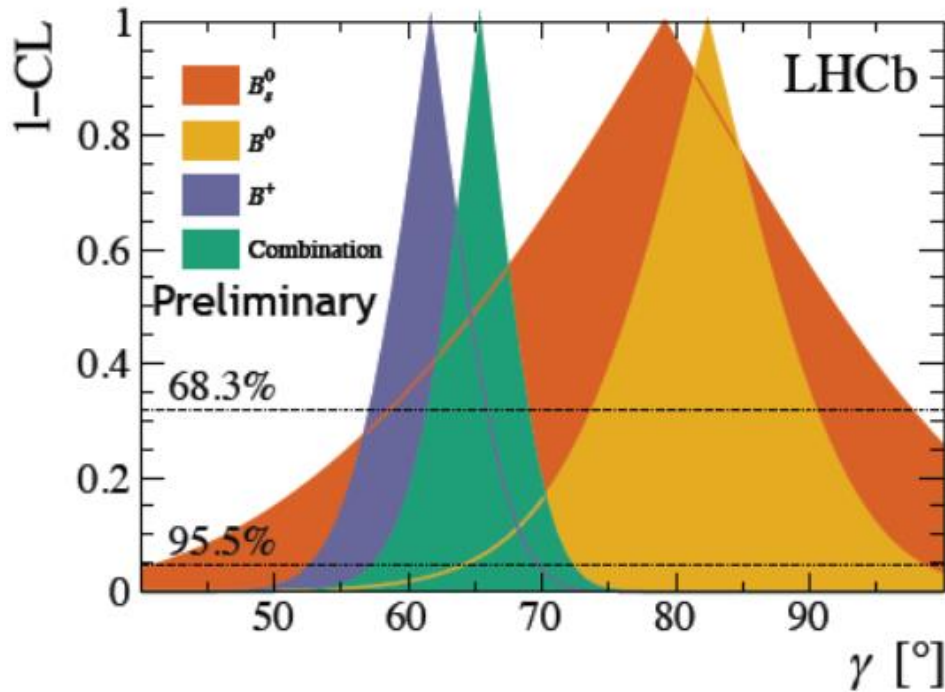

# CP violation in $B^\pm \rightarrow h^\pm h^+ h^-$

NEW

LHCb-PAPER-2021-049/050

- CPV observed in four decay channels:
  - ◆  $B^\pm \rightarrow K^\pm \pi^+ \pi^-$ ,  $B^\pm \rightarrow K^\pm K^+ K^-$
  - $B^\pm \rightarrow \pi^\pm \pi^+ \pi^-$ ,  $B^\pm \rightarrow \pi^\pm K^+ K^-$
- Large and interesting localised CP-asymmetries observed
- The biggest difference is observed for the  $B^\pm \rightarrow \pi^\pm \pi^+ \pi^-$  and  $B^\pm \rightarrow \pi^\pm K^+ K^-$  decays ( $14 \sigma$ )
- However the CP asymmetry of  $B^\pm \rightarrow K^\pm \pi^+ \pi^-$  decays compatible with zero
- Hard to know what this all means. Possible information about the relation between decay channels eg  $\pi\pi \leftrightarrow KK$  rescattering

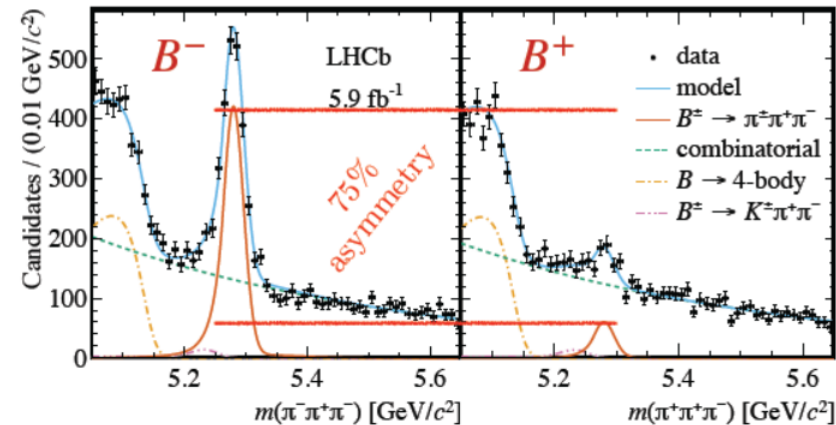
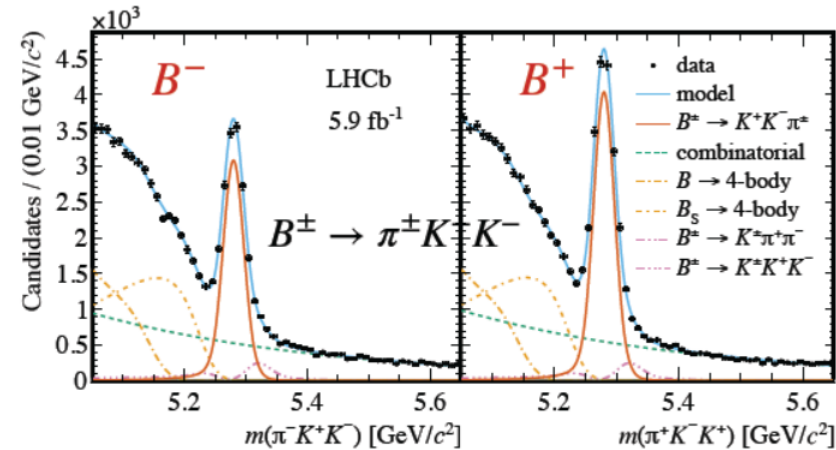

# B<sub>(s)</sub> mixing at LHCb

Previous Workshop

$$\frac{N(B^0 \rightarrow B^0) - N(B^0 \rightarrow \bar{B}^0)}{N(B^0 \rightarrow B^0) + N(B^0 \rightarrow \bar{B}^0)}$$

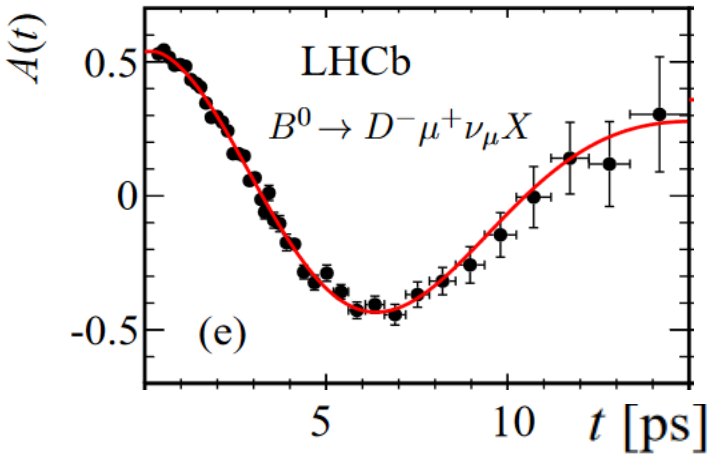

$$\Delta m_d = (505.0 \pm 2.1 \pm 1.0) \text{ ns}^{-1}$$

Eur. Phys. J. C76 (2016) 412

Mixing measurements dominated by LHCb

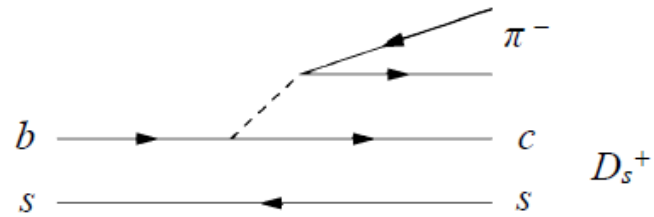
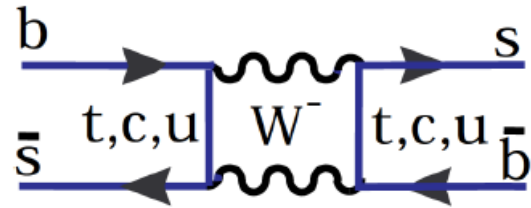

—  $B_s^0 \rightarrow D_s^- \pi^+$     —  $\bar{B}_s^0 \rightarrow B_s^0 \rightarrow D_s^- \pi^+$     — Untagged

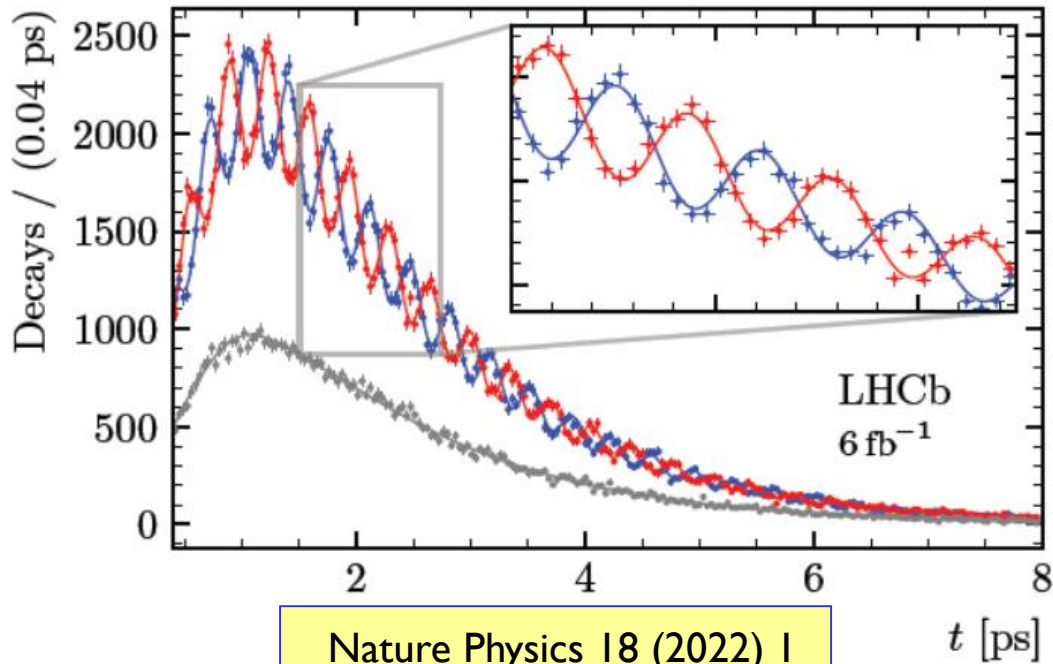

$$\Delta m_s = 17.7683 \pm 0.0051 \pm 0.0032 \text{ ps}^{-1}$$

# CP violation in charm

- Direct CP violation

Measure asymmetry

$$\left| D^0 \rightarrow f \right|^2 \neq \left| \bar{D}^0 \rightarrow \bar{f} \right|^2 \quad A(D \rightarrow f) = \frac{N(D \rightarrow f) - N(\bar{D} \rightarrow \bar{f})}{N(D \rightarrow f) + N(\bar{D} \rightarrow \bar{f})}$$

- Most promising channels are *Cabibbo-suppressed* (CS) decays where CPV may arise from the *interference* between the **tree** and the **penguin** amplitudes

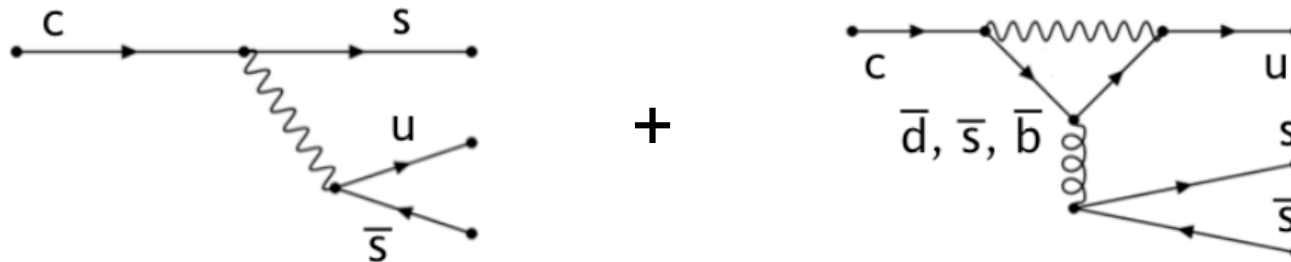

- SM prediction is very small  $O(10^{-4}) \rightarrow O(10^{-3})$

# Reminder of the “ $\Delta A_{CP}$ ” measurement

- Tag  $D^0$  and  $\bar{D}^0$  via “prompt” and “semileptonic” decays:

- ◆ Prompt: coming from primary vertex, i.e.  $D^{*+-} \rightarrow \bar{D}^0 \pi_{soft}^{+-}$

- ◆ Semileptonic: coming from B-decays, i.e.  $B^{+-} \rightarrow \bar{D}^0 \mu^{+-} X$

- The *raw* asymmetry (**A**) in Cabibbo-suppressed  $D^0 \rightarrow h^- h^+$  decays ( $h = K$  or  $\pi$ ) defined as

$$A(D \rightarrow f) = \frac{N(D \rightarrow f) - N(\bar{D} \rightarrow \bar{f})}{N(D \rightarrow f) + N(\bar{D} \rightarrow \bar{f})}$$

Phys. Rev. Lett. 122  
(2019) 211803

includes physics and detector effects:

$$A = A_{CP} + A_D + A_P$$

Detection asymmetry  
from  $\pi_{soft}^+$  or  $\mu^+$

Production asymmetry  
from  $D^{*+}$  or B decays

- To eliminate these contributions and cancel the systematics measure :

$$\Delta A_{CP} = A(K^- K^+) - A(\pi^- \pi^+) = A_{CP}(K^- K^+) - A_{CP}(\pi^- \pi^+)$$



# Observation of CPV in charm decays

- Measurement performed with combined Run I and Run 2 data-set

Phys. Rev. Lett. 122 (2019) 211803

$$\Delta A_{CP} = [-15.4 \pm 2.9] \times 10^{-4}$$

- The first measurement of CPV in the charm system ( $5.3\sigma$ ) !
- However this doesn't pin down the channel which the CP violation is in

Prompt

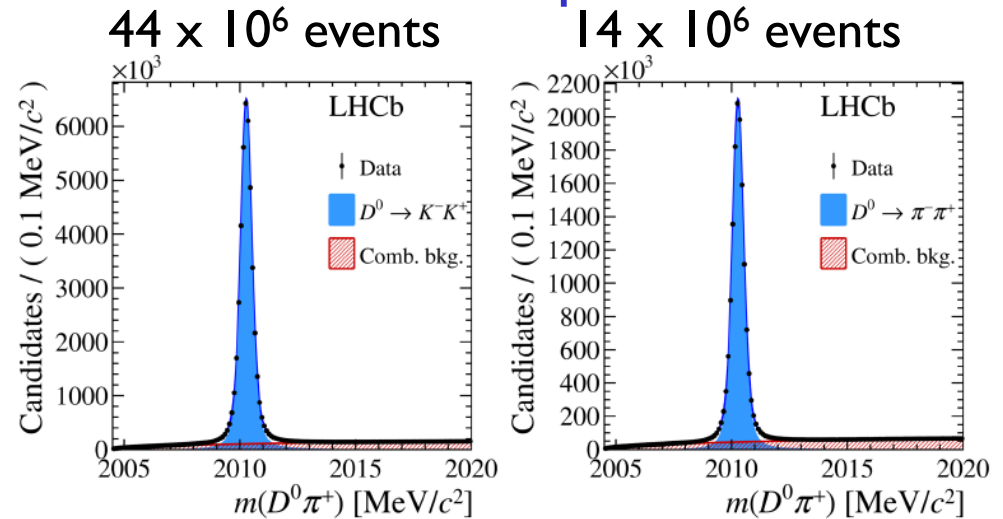

Semi-leptonic

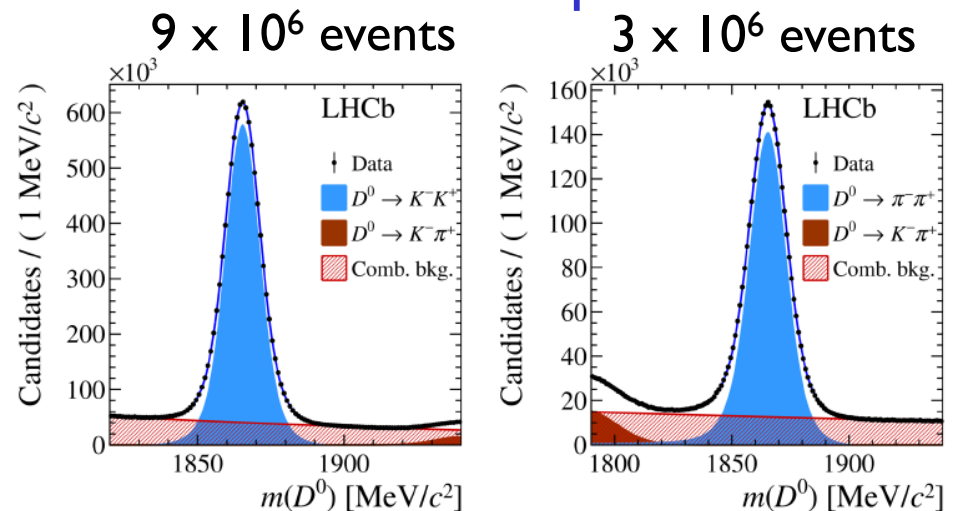

# CP violation in a *specific* charm hadron decay

LHCb-PAPER-2022-024 (in preparation)



- New measurement of  $A_{CP}(K^-K^+)$  :

$$A_{CP}(K^-K^+) = [6.8 \pm 5.4(\text{stat}) \pm 1.6(\text{syst})] \times 10^{-4}$$

then determine the direct CP asymmetries in  $\pi^- \pi^+$  from  $\Delta A_{CP}$

$$a_{K^-K^+}^d = (7.7 \pm 5.7) \times 10^{-4}$$

$$a_{\pi^- \pi^+}^d = (23.2 \pm 6.1) \times 10^{-4} *$$

- First evidence in a single channel ( $3.8\sigma$  in  $D^0 \rightarrow \pi^- \pi^+$ ) for direct CP violation ( $1.4\sigma$  in  $D^0 \rightarrow K^- K^+$ )
- Yet unclear if consistent with SM or new dynamics in charm decays

\* An aside : The  $A_{CP}$ 's are time-integrated, but contributions from the time-dependent CP violation for charm mixing have been subtracted in  $a_{K^-K^+}^d$  and  $a_{\pi^- \pi^+}^d$ .

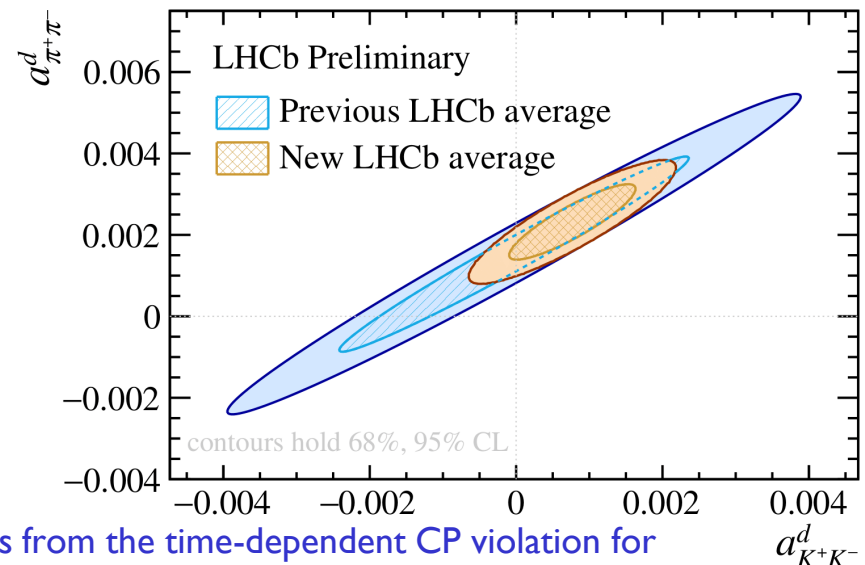
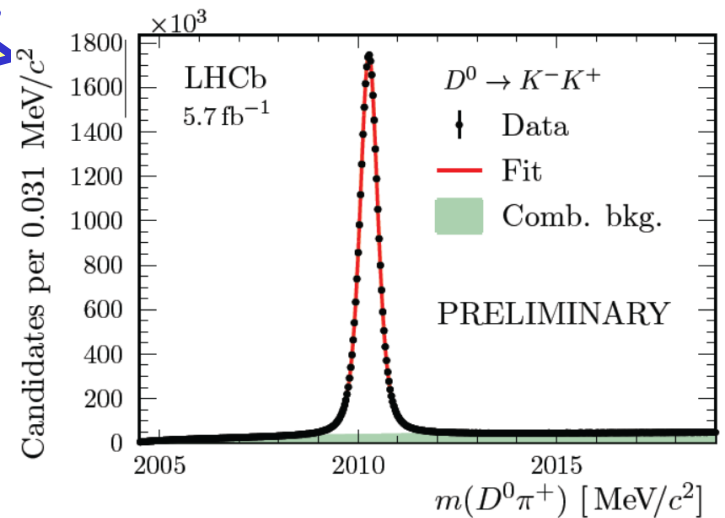



NEW

# Charm mixing parameter $y_{CP} - y_{CP}^{K\pi}$

- Study the  $D^0$  meson decays into  $K^-K^+$ ,  $\pi^-\pi^+$  and  $K^-\pi^+$
- The decay  $D^0 \rightarrow K^-\pi^+$  is a CP-mixed state with  $\tau(D^0 \rightarrow K^-\pi^+) \approx 1/\Gamma$ ; the decay  $D^0 \rightarrow f$  is a CP-even state with  $\tau(D^0 \rightarrow f) < \tau(D^0 \rightarrow K^-\pi^+)$

$$f = KK, \pi\pi$$

- Measure ratio :

$$R^f(t) = \frac{N(D^0 \rightarrow f, t)}{N(D^0 \rightarrow K^-\pi^+, t)} \propto e^{-(y_{CP}^f - y_{CP}^{K\pi})t/\tau_{D^0}} \frac{\varepsilon(f, t)}{\varepsilon(K^-\pi^+, t)}$$

$$\approx -0.4 \times 10^{-3}$$

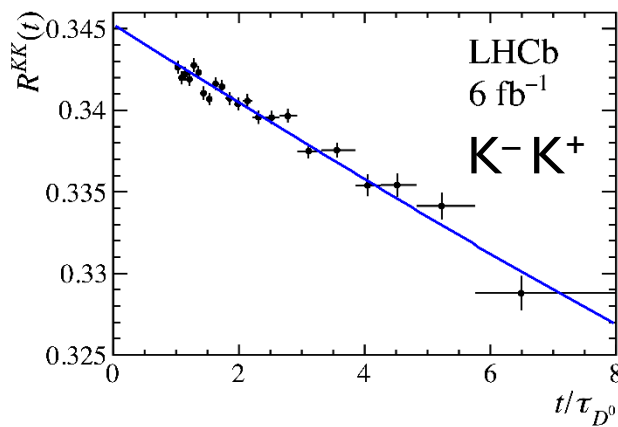
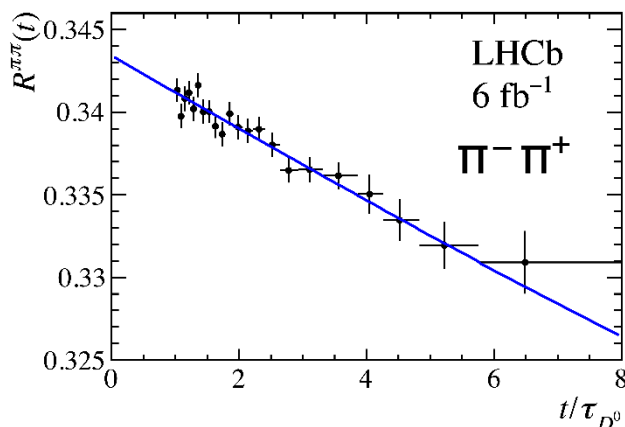

$$y_{CP}^{\pi\pi} - y_{CP}^{K\pi} = (6.57 \pm 0.53 \pm 0.16) \times 10^{-3}$$

$$y_{CP}^{KK} - y_{CP}^{K\pi} = (7.08 \pm 0.30 \pm 0.14) \times 10^{-3}$$

PRD 105 (2022) 092013

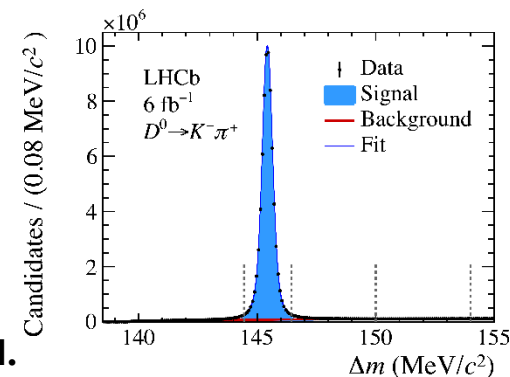
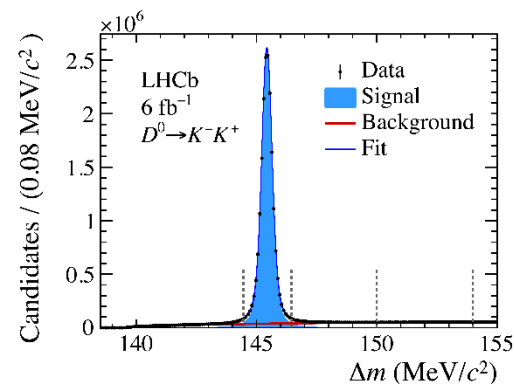
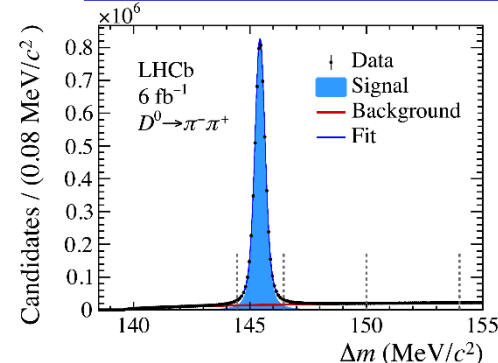

# $D^0$ mixing parameter $y_{CP} - y_{CP}^{K\pi}$

PRD 105 (2022) 092013

## ■ Measure ratio :

$$R^f(t) = \frac{N(D^0 \rightarrow f, t)}{N(D^0 \rightarrow K^-\pi^+, t)} \propto e^{-(y_{CP}^f - y_{CP}^{K\pi})t/\tau_{D^0}} \frac{\varepsilon(f, t)}{\varepsilon(K^-\pi^+, t)}$$

$f = KK, \pi\pi$

$$y_{CP}^{\pi\pi} - y_{CP}^{K\pi} = (6.57 \pm 0.53 \pm 0.16) \times 10^{-3}$$

$$y_{CP}^{KK} - y_{CP}^{K\pi} = (7.08 \pm 0.30 \pm 0.14) \times 10^{-3}$$

## ■ Combine :

$$y_{CP} - y_{CP}^{K\pi} = (6.96 \pm 0.26 \pm 0.13) \times 10^{-3}$$

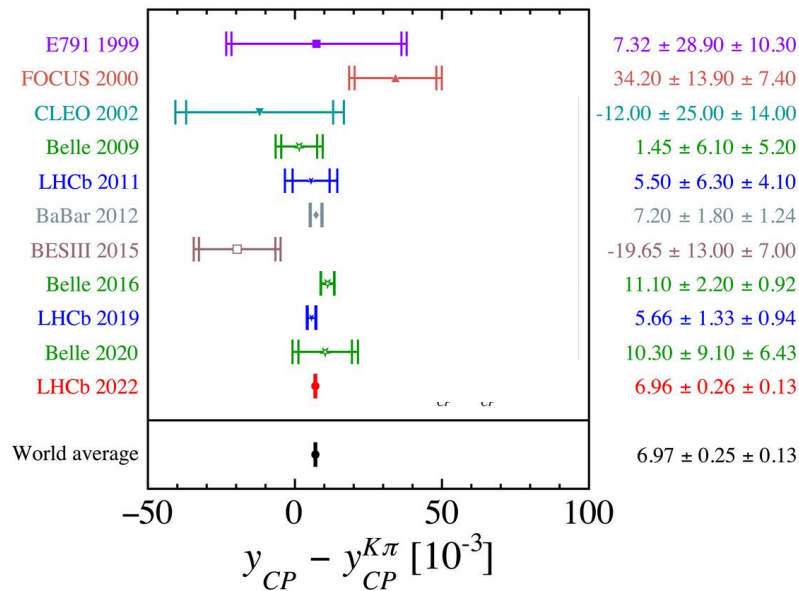

This measurement is **four times** more precise than the previous world average value.

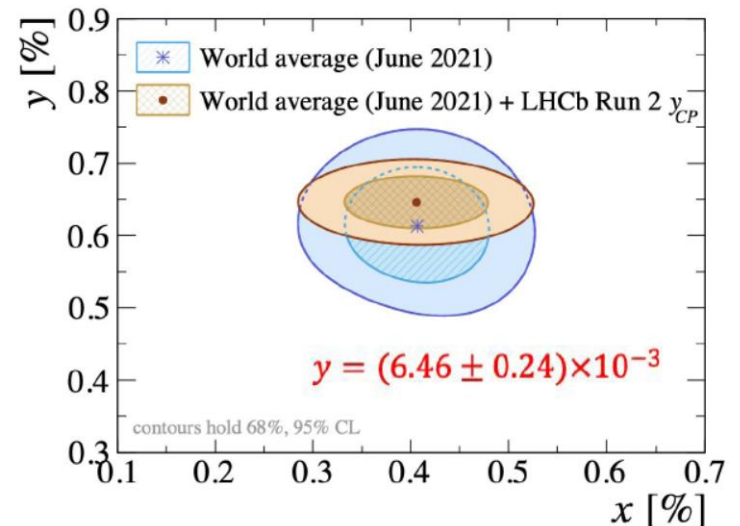



# New (exotic) spectroscopy measurements

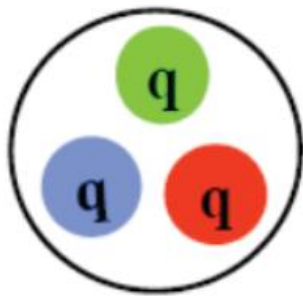

Baryon

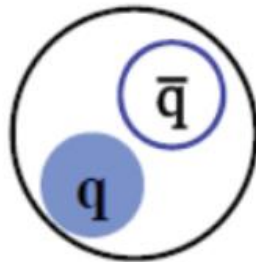

Meson

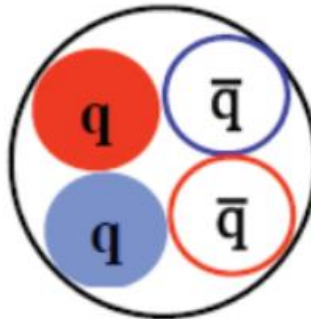

Tetraquark

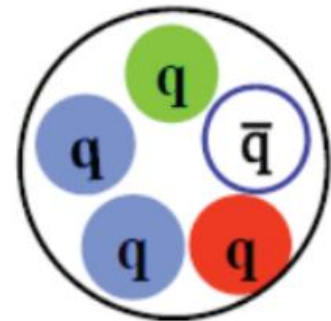

Pentaquark

# Reminder: tetra/pentaquark discoveries

- Discovery of  $\chi_{c1}(3872)$  (formerly  $X(3872)$ ) by Belle in 2003 started new era in exotic spectroscopy
- First observation of  $P_c(4312)^+$ ,  $P_c(4440)^+$  and  $P_c(4457)^+$  by LHCb as narrow resonances in the mass spectrum of  $(J/\psi p)$  in  $\Lambda_b \rightarrow (J/\psi p) K^-$  decays PRL 115 (2015) 072001, PRL 122 (2019) 222001
- Consistent with  $c\bar{c}uud$  pentaquarks : allowed by QCD, but not observed in 50 years of searching.

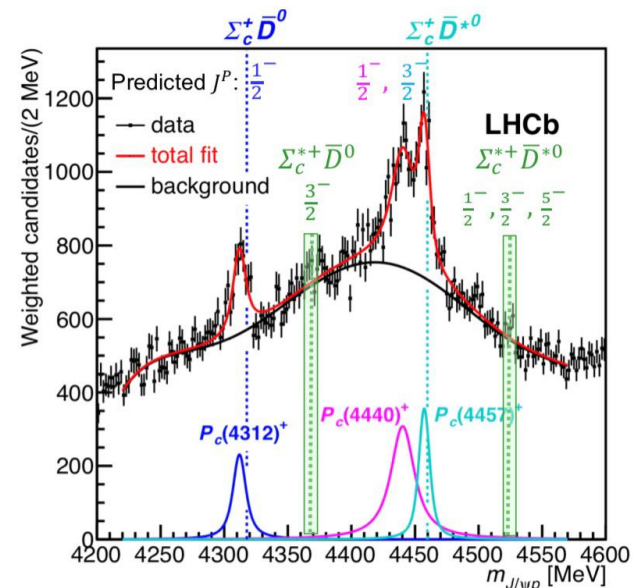
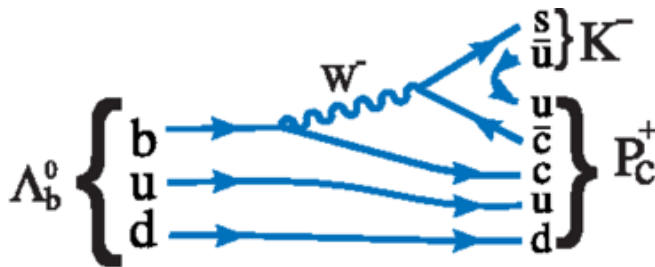

# New hadron discoveries at the LHC

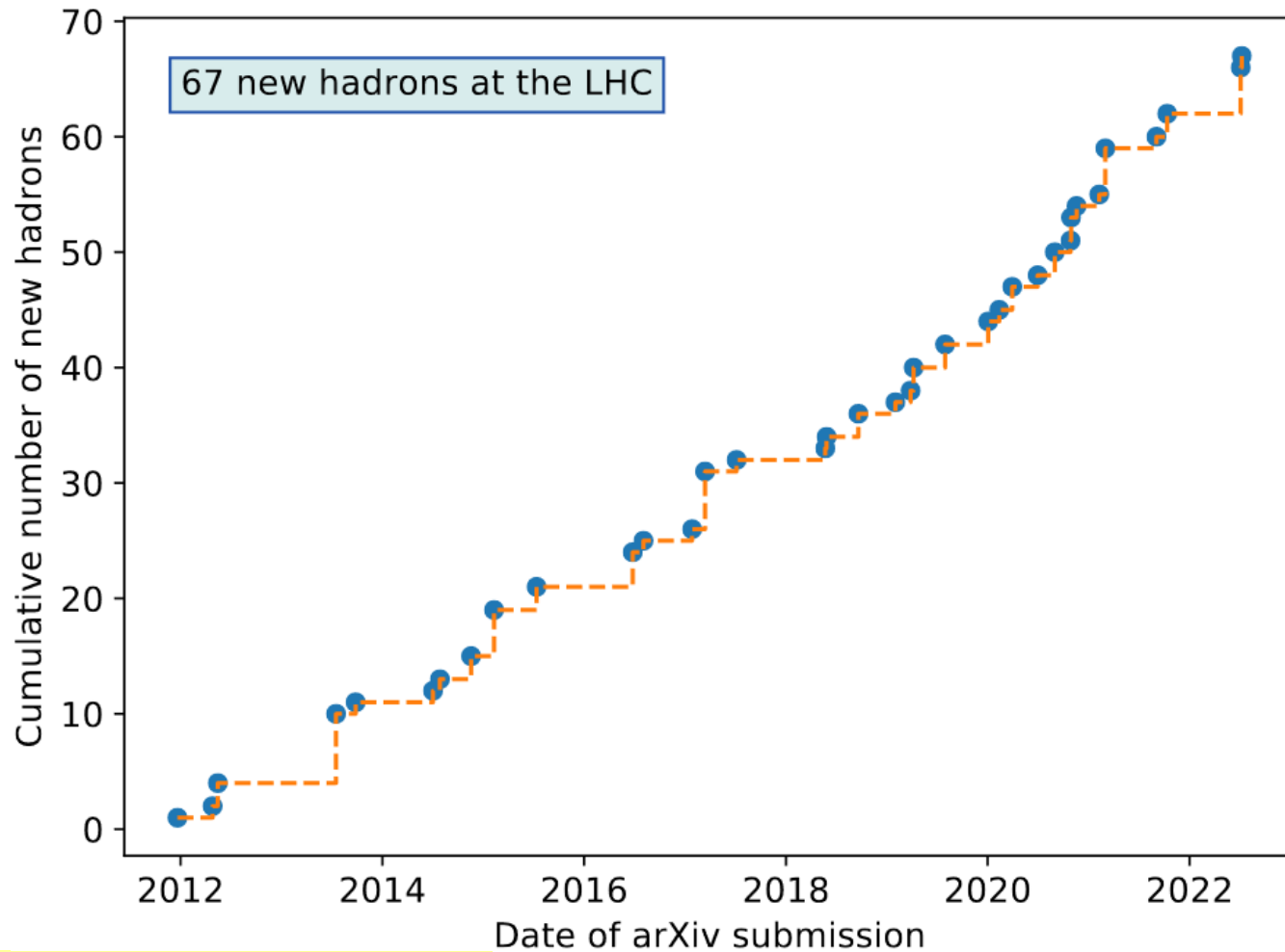

With thanks to Patrick Koppenburg  
LHCb-FIGURE-2021-001 (update)

# New hadron discoveries at LHCb

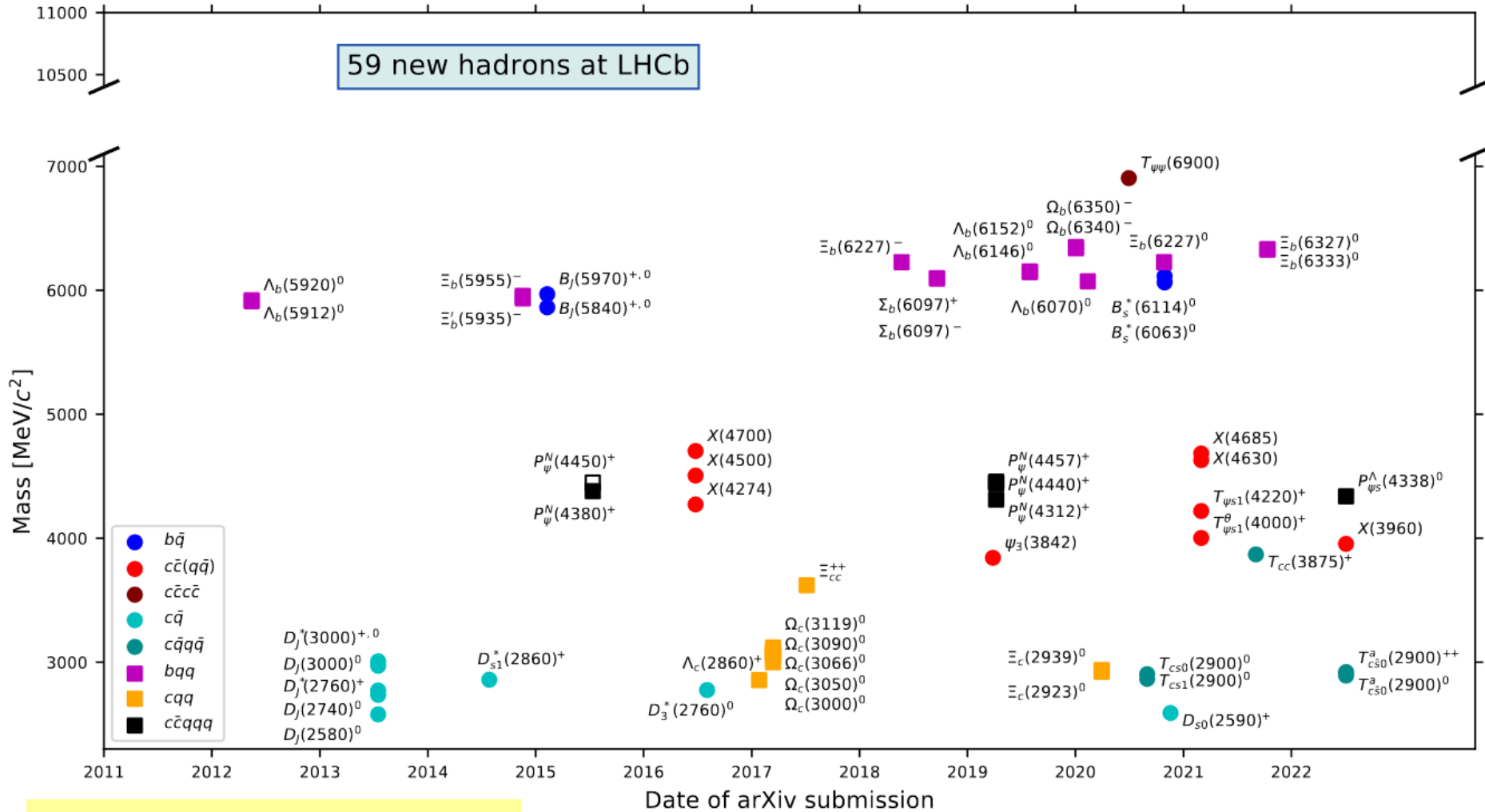

With thanks to Patrick Koppenburg  
LHCb-FIGURE-2021-001 (update)

# Need for a new naming scheme (proposal)

T.Gershon/LHCb : arXiv:2206.15233

■ Currently no PDG rule for :

- ◆ exotic mesons with s, c, b quantum numbers
- ◆ no extension for pentaquark states

T states zero net S, C, B			T states non-zero net S, C, B				P states			
(P, G)	I = 0	I = 1	(P)	I = 0	I = 1/2	I = 1	I = 0	I = 1/2	I = 1	I = 3/2
(-, -)	$\omega$	$\pi$	(-)	$\eta$	$\tau$	$\pi$	$\Lambda$	$N$	$\Sigma$	$\Delta$
(-, +)	$\eta$	$\rho$	(+)	$f$	$\theta$	$a$				
(+, +)	$f$	$b$								
(+, -)	$h$	$a$								

■ Idea of the proposal :

- ◆ T for tetra, P for penta
- ◆ **Superscript:** based on existing symbols, to indicate isospin, parity and G-parity
- ◆ **Subscript:** heavy quark content

Minimal quark content	Current name	$I^{(G)}, J^{P(C)}$	Proposed name
$c\bar{c}$	$\chi_{c1}(3872)$	$I^G = 0^+, J^{PC} = 1^{++}$	$\chi_{c1}(3872)$
$c\bar{c}u\bar{d}$	$Z_c(3900)^+$	$I^G = 1^+, J^P = 1^+$	$T_{\psi 1}^b(3900)^+$
$c\bar{c}u\bar{d}$	$Z_c(4100)^+$	$I^G = 1^-$	$T_{\psi}(4100)^+$
$c\bar{c}u\bar{d}$	$Z_c(4430)^+$	$I^G = 1^+, J^P = 1^+$	$T_{\psi 1}^b(4430)^+$
$c\bar{c}u\bar{s}$	$Z_{cs}(4000)^+$	$I = \frac{1}{2}, J^P = 1^+$	$T_{\psi s 1}^{\theta}(4000)^+$
$c\bar{c}u\bar{s}$	$Z_{cs}(4220)^+$	$I = \frac{1}{2}, J^P = 1^?$	$T_{\psi s 1}(4220)^+$
$c\bar{c}c\bar{c}$	$X(6900)$	$I^G = 0^+, J^{PC} = ?^{?+}$	$T_{\psi\psi}(6900)$
$cs\bar{u}\bar{d}$	$X_0(2900)$	$J^P = 0^+$	$T_{cs 0}(2900)^0$
$cs\bar{u}\bar{d}$	$X_1(2900)$	$J^P = 1^-$	$T_{cs 1}(2900)^0$
$cc\bar{u}\bar{d}$	$T_{cc}(3875)^+$		$T_{cc}(3875)^+$
$bb\bar{u}\bar{d}$	$Z_b(10610)^+$	$I^G = 1^+, J^P = 1^+$	$T_{\gamma 1}^b(10610)^+$
$c\bar{c}uud$	$P_c(4312)^+$	$I = \frac{1}{2}$	$P_{\psi}^N(4312)^+$
$c\bar{c}uds$	$P_{cs}(4459)^0$	$I = 0$	$P_{\psi s}^{\Lambda}(4459)^0$

# Observation of a $J/\psi\Lambda$ resonance in $B^- \rightarrow J/\psi\Lambda p$ decays

**NEW**

LHCb-PAPER-2022-031 (in preparation)

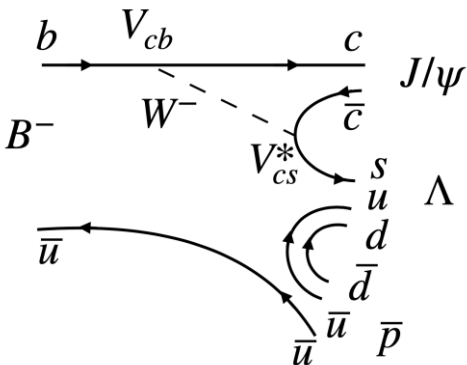
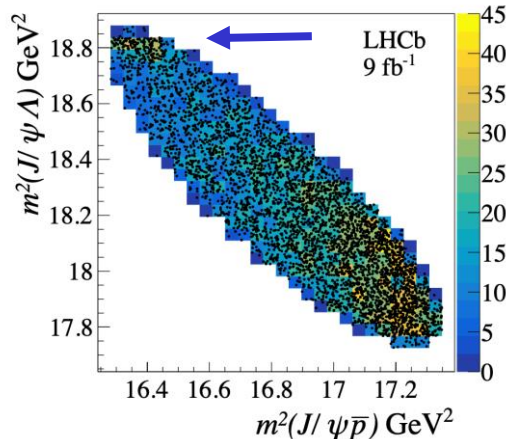

- Study of  $B^- \rightarrow J/\psi\Lambda\bar{p}$  decays
- Observe  $P_{\psi_s}^\Lambda (J/\psi\Lambda)$  pentaquark with strange quark content  $\bar{c}\bar{c}uds$  close to  $\Xi_c^+ D^-$  threshold (with  $>10\sigma$  significance)
- $m(P_{\psi_s}^\Lambda (J/\psi\Lambda)) = 4338.2 \pm 0.7 \pm 0.4$  MeV  
 $\Gamma(P_{\psi_s}^\Lambda (J/\psi\Lambda)) = 7.0 \pm 1.2 \pm 1.3$  MeV
- Spin  $1/2$  is assigned.  $J^P = 1/2^+$  preferred

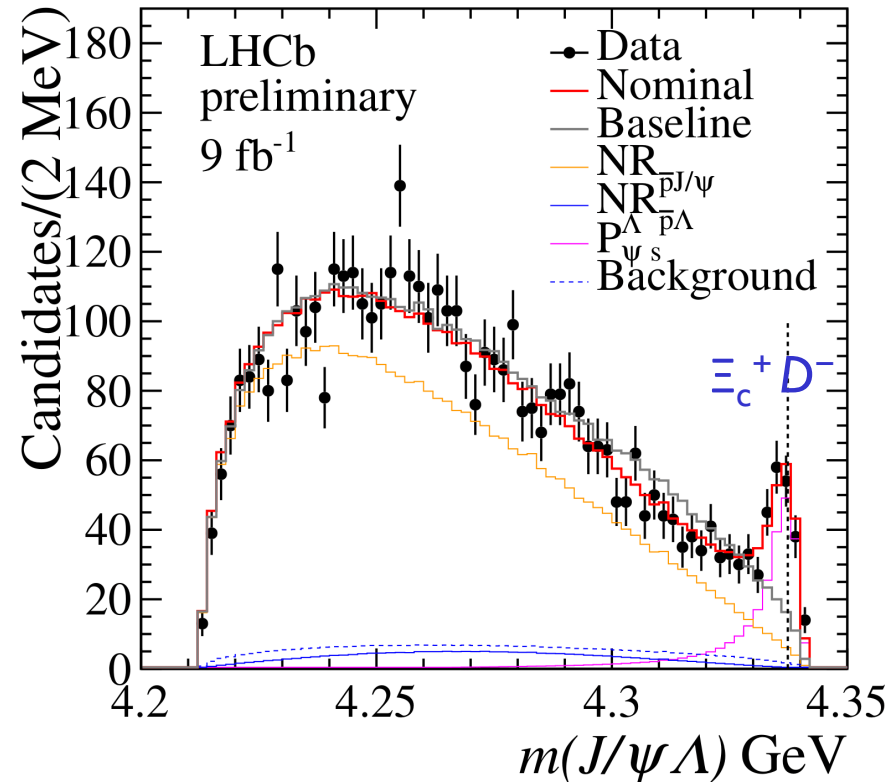

This is the first observation of a strange pentaquark



# An interesting aside – B mass measurement

LHCb-PAPER-2022-031 (in preparation)

NEW

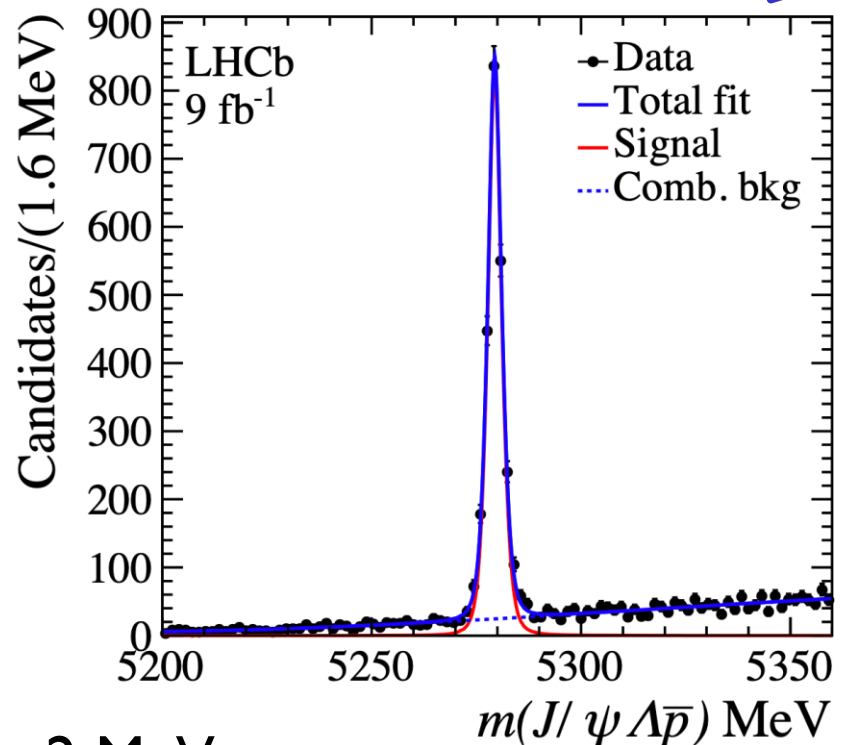
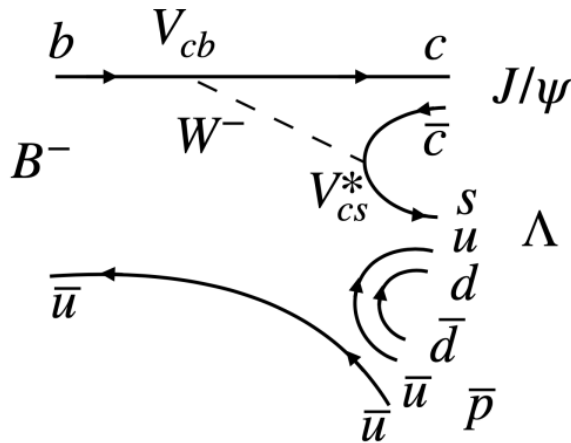

- Small Q-value  $\approx 128$  MeV.
- Resolution on  $m(J/\psi \Lambda \bar{p})$   $\sigma \approx 2$  MeV
- Leads to the most precise  $B^-$  mass measurement  
 $m(B^-) = 5279.44 \pm 0.05$  (stat)  $\pm 0.07$  (syst) MeV

# Nature of pentaquarks ?

Possible models describing the observed pentaquark states :

- Tightly bounded states?
- Meson-baryon molecules?

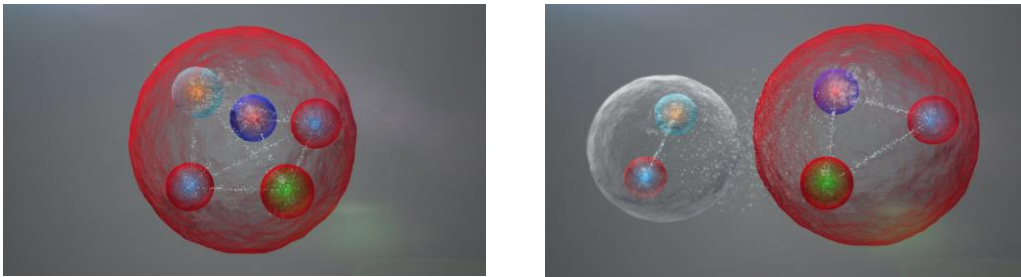

- Re-scattering effects?

- Molecular-state model likely favoured when bound mesons and baryons form narrow resonances just below mass thresholds
- More work needed

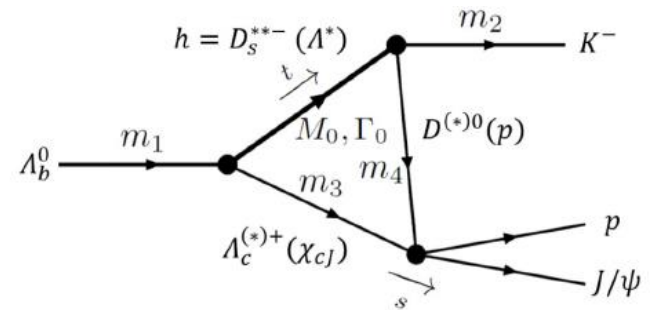

# Recent 4-quark states from LHCb

NEW

- Observation of isospin triplet  $[c\bar{s}u\bar{d}]$  4-quark states in  $D_s^+\pi^-$  mass spectrum in  $B^0 \rightarrow \bar{D}^0 D_s^+\pi^-$  and  $B^+ \rightarrow D^- D_s^+\pi^+$  decays

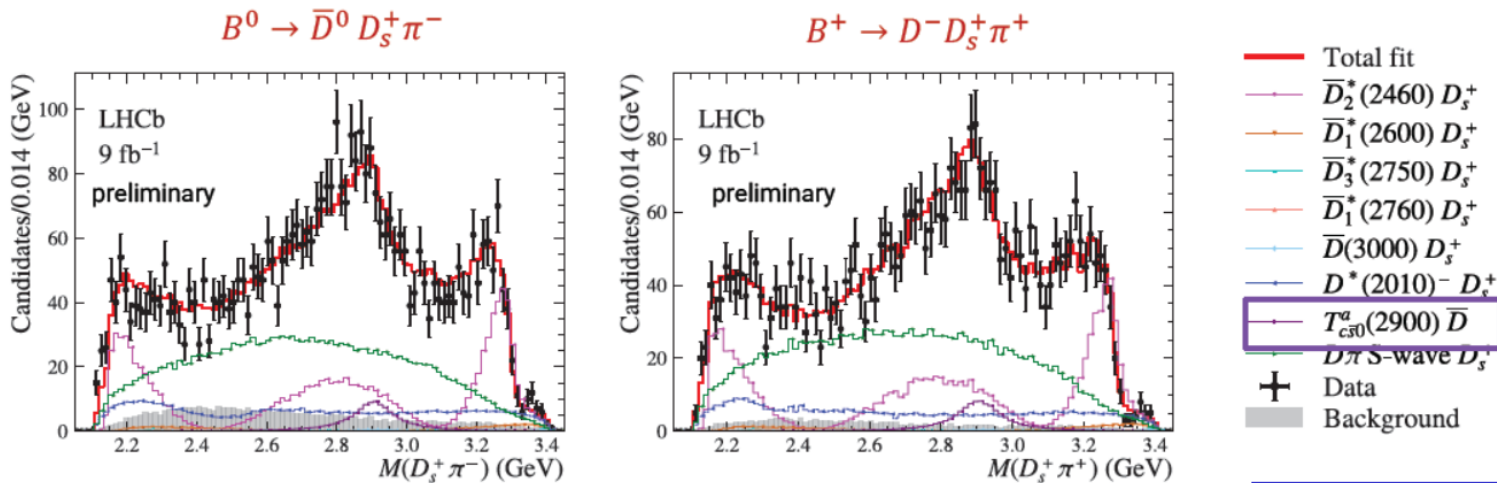

$$M = 2.908 \pm 0.011 \pm 0.020 \text{ GeV}$$

$$\Gamma = 0.136 \pm 0.023 \pm 0.011 \text{ GeV}$$

LHCb-PAPER-2022-026/027  
(in preparation)

$m(D_s^+\pi^-)$  well described by adding  $J^P=0^+$  tetraquark states  $T_{c\bar{s}0}^a(2900)^0$  and  $T_{c\bar{s}0}^a(2900)^{++}$  in both channels ( $7.5 \sigma$ )

# Rare decays and lepton universality

# Rare decays : why interesting

- In the SM, processes involving flavour changing neutral currents (FCNCs) are forbidden at tree level but can occur at loop level (penguin and box)

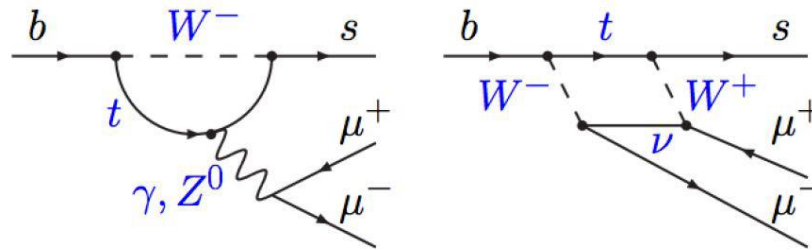
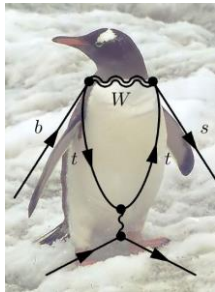

$b \rightarrow s \ell^+ \ell^-$   
transitions  
(BF  $10^{-6}$  to  $10^{-10}$ )

- New particles too heavy to be produced directly, can give sizeable effects when exchanged in a loop

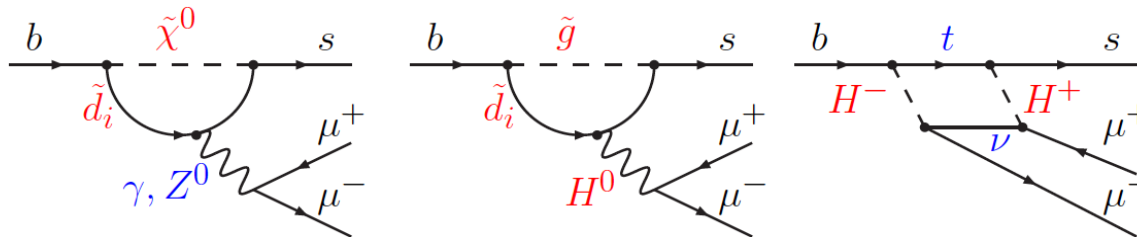

- This “indirect” approach to New Physics searches is complementary to that of ATLAS/ CMS

$$B_{(s)} \rightarrow \mu^+ \mu^-$$

- Very suppressed loop decay in the SM
- CKM ( $|V_{ts}|^2$  for  $B_s$ ) and helicity suppressed  $\sim (m_\mu/m_b)^2$
- Theoretically “clean”  $\rightarrow$  4% prediction :

$$\mathcal{B}(B_s^0 \rightarrow \mu^+ \mu^-)_{\text{SM}} = (3.66 \pm 0.14) \times 10^{-9}$$

$$\mathcal{B}(B^0 \rightarrow \mu^+ \mu^-)_{\text{SM}} = (1.03 \pm 0.05) \times 10^{-10}$$

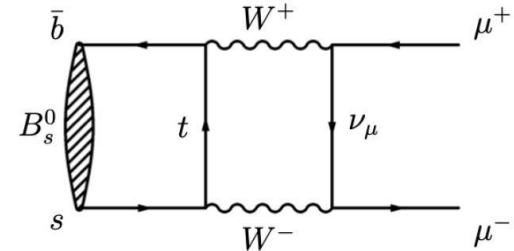
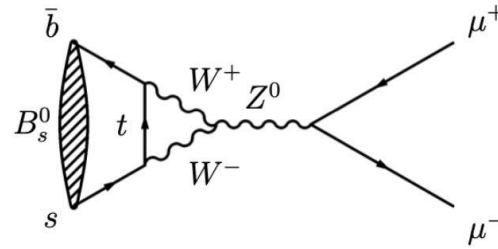

Bobeth et al. PRL 112 (2014) 101801  
Beneke et al. JHEP 10 (2019) 232

- NP theories can predict significantly higher values for the branching ratios
- Very clean experimental signature
- Also studied by ATLAS & CMS

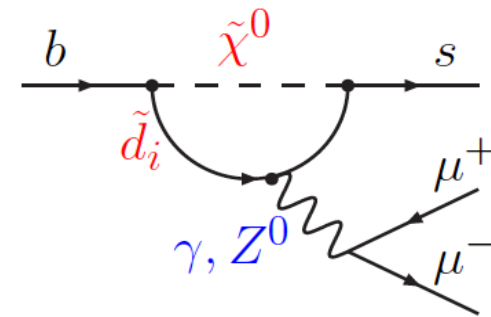

# 35 years of effort !

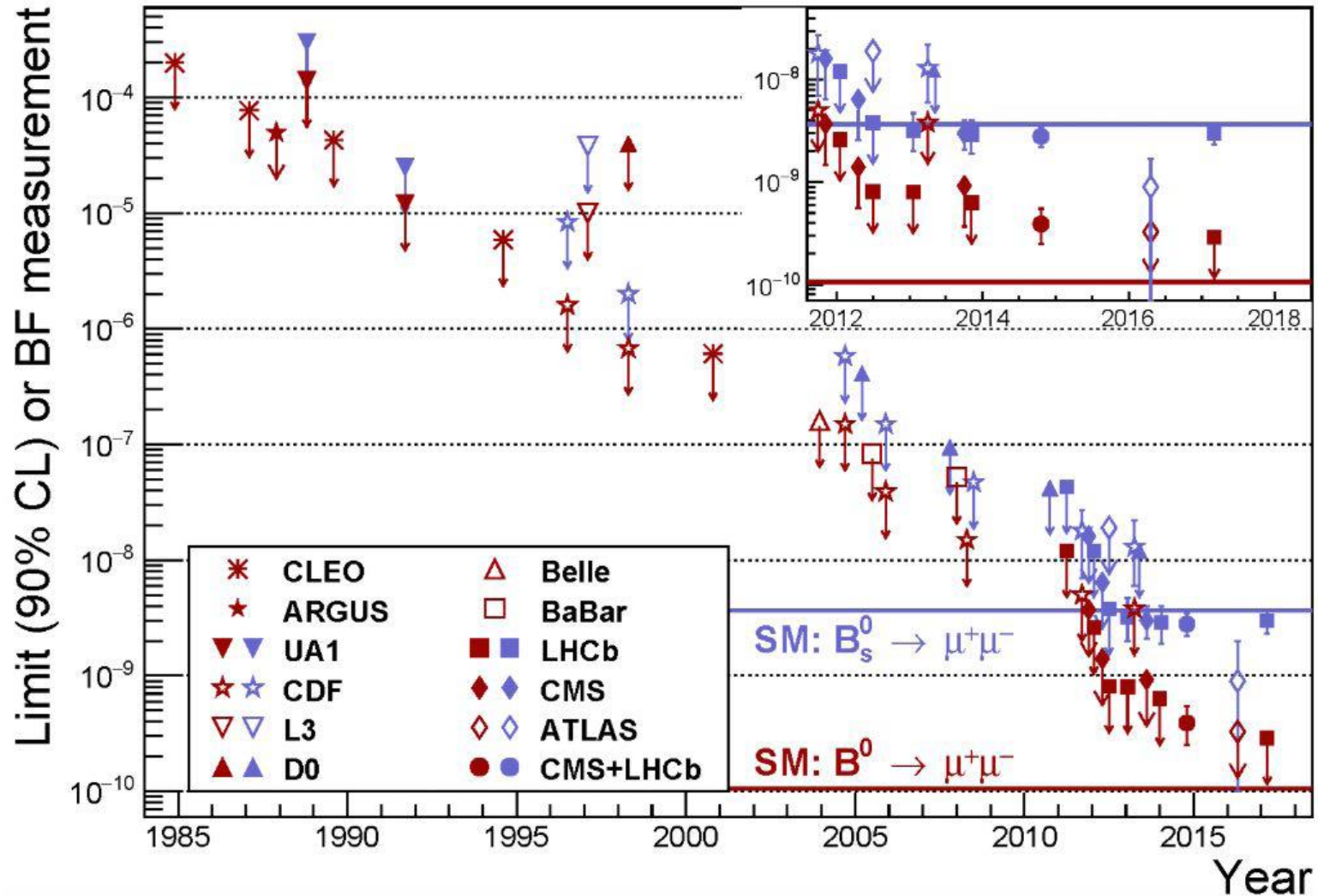



# A needle in a haystack

PRL 120 (2018) 061801

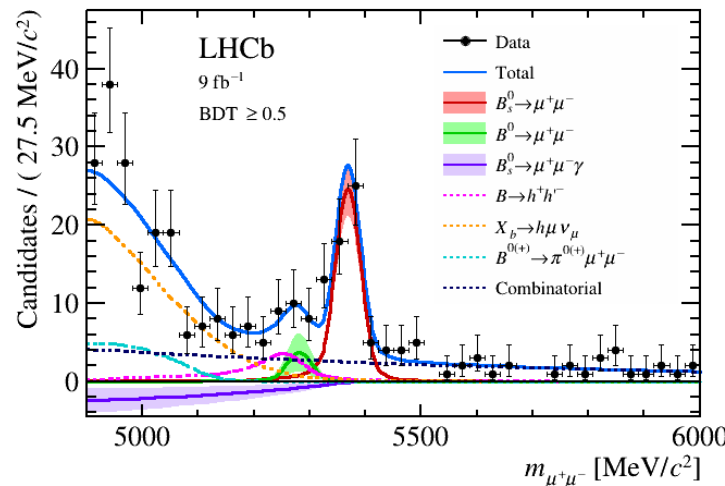
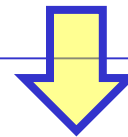
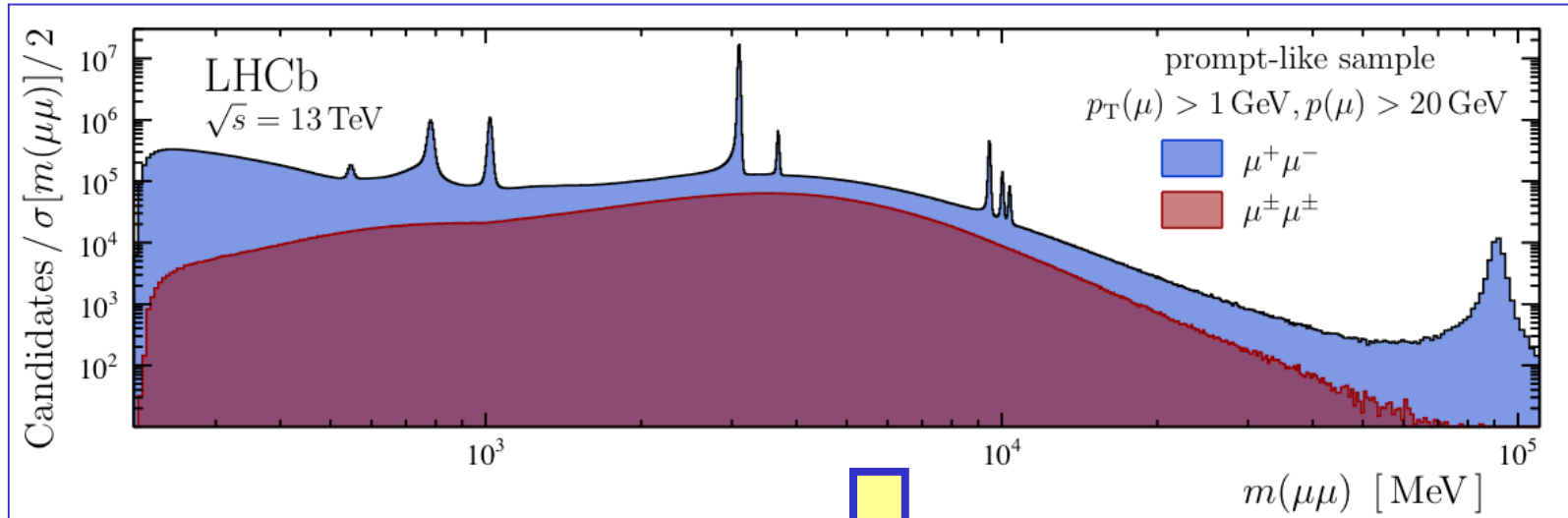

# $B_{(s)} \rightarrow \mu^+ \mu^-$ latest result

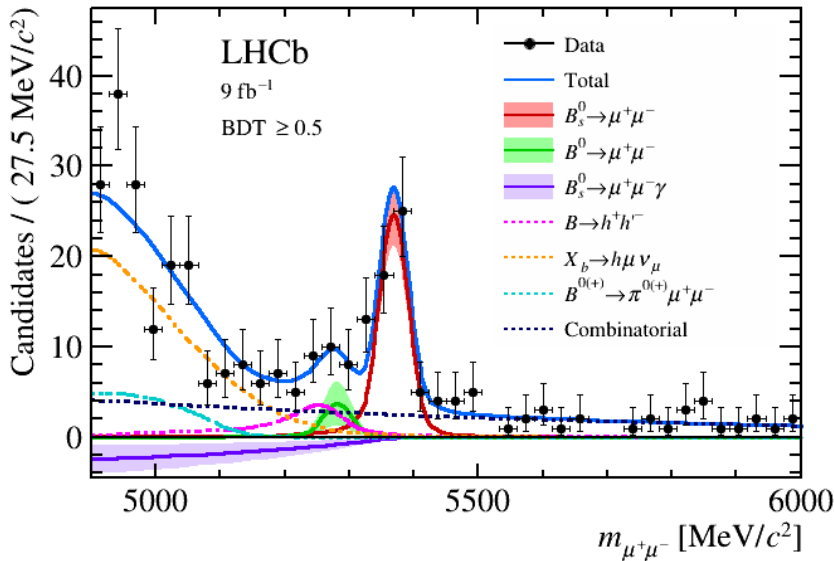

Phys Rev D 105 (2022) 012010  
Phys. Rev. Lett. 128, 041801

$$\mathcal{B}(B_s^0 \rightarrow \mu^+ \mu^-) = (3.09^{+0.46}_{-0.43} \quad ^{+0.15}_{-0.11}) \times 10^{-9} \quad | \quad (10\sigma)$$

$$\mathcal{B}(B^0 \rightarrow \mu^+ \mu^-) = (1.20^{+0.83}_{-0.74} \pm 0.14) \times 10^{-10} \quad (< 2.6 \times 10^{-10} @ 95\%CL)$$

- $B_s^0 \rightarrow \mu^+ \mu^-$  found with significance  $> 10$  sigma
  - ◆ But no evidence yet for  $B^0 \rightarrow \mu^+ \mu^-$  (1.7 sigma)
- Result dominated by statistical uncertainty

■ Latest CMS results

$$\mathcal{B}(B_s^0 \rightarrow \mu^+ \mu^-) = [3.83^{+0.38}_{-0.36} \text{ (stat)} \quad ^{+0.19}_{-0.16} \text{ (syst)} \quad ^{+0.14}_{-0.13} (f_s/f_u)] \times 10^{-9}$$

$$\mathcal{B}(B^0 \rightarrow \mu^+ \mu^-) = [0.37^{+0.75}_{-0.67} \text{ (stat)} \quad ^{+0.08}_{-0.09} \text{ (syst)}] \times 10^{-10}$$

# $B_{(s)} \rightarrow \mu^+ \mu^-$ latest result and LHC combination

Phys Rev D 105 (2022) 012010

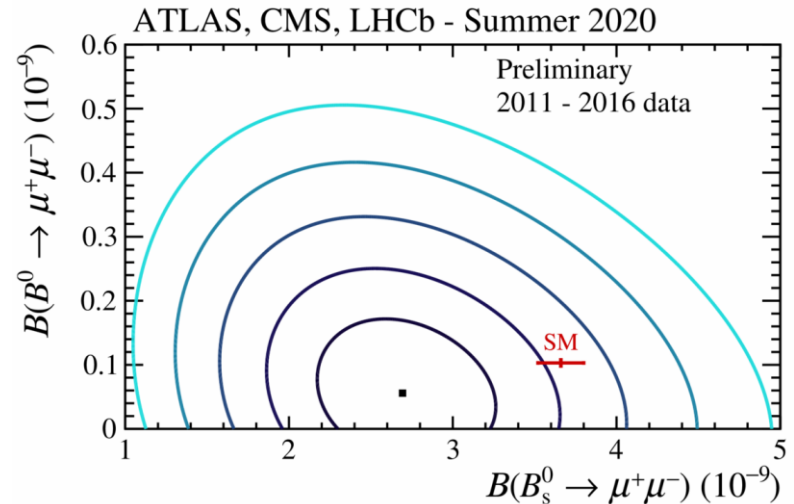
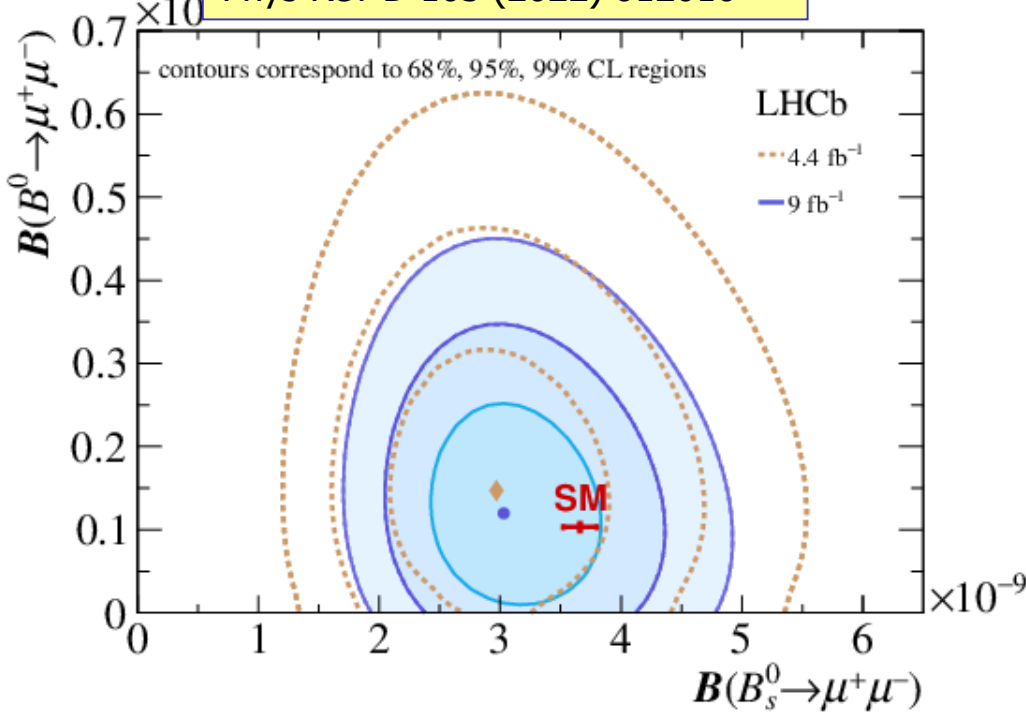

LHCb-CONF-2020-002  
 CMS PAS BPH-20-003  
 ATLAS-CONF-2020-049

## LHCb

$$\mathcal{B}(B_s^0 \rightarrow \mu^+ \mu^-) = (3.09^{+0.46}_{-0.43} \quad ^{+0.15}_{-0.11}) \times 10^{-9} \quad (10\sigma)$$

$$\mathcal{B}(B^0 \rightarrow \mu^+ \mu^-) = (1.20^{+0.83}_{-0.74} \pm 0.14) \times 10^{-10}$$

Combination  
 2.1 $\sigma$  below  
 SM prediction

# Effective $B_S$ lifetime

Phys Rev D 105 (2022) 012010  
Phys. Rev. Lett. 128, 041801

- For  $B_S$  mesons, there is a sizeable difference between the decay widths  $\Delta\Gamma_S$  of the light and heavy mass eigenstates ( $\Delta\Gamma_S = 0.085 \pm 0.004 \text{ ps}^{-1}$ ) PDG

- In the SM, the  $B_S$  system evolves with the lifetime of the heavy mass eigenstate (since CP odd).

- Define the  $B_S^0 \rightarrow \mu^+\mu^-$  effective lifetime as

$$\tau_{\mu^+\mu^-} \equiv \frac{\int_0^\infty t \Gamma(B_S(t) \rightarrow \mu^+\mu^-) dt}{\int_0^\infty \Gamma(B_S(t) \rightarrow \mu^+\mu^-) dt}$$

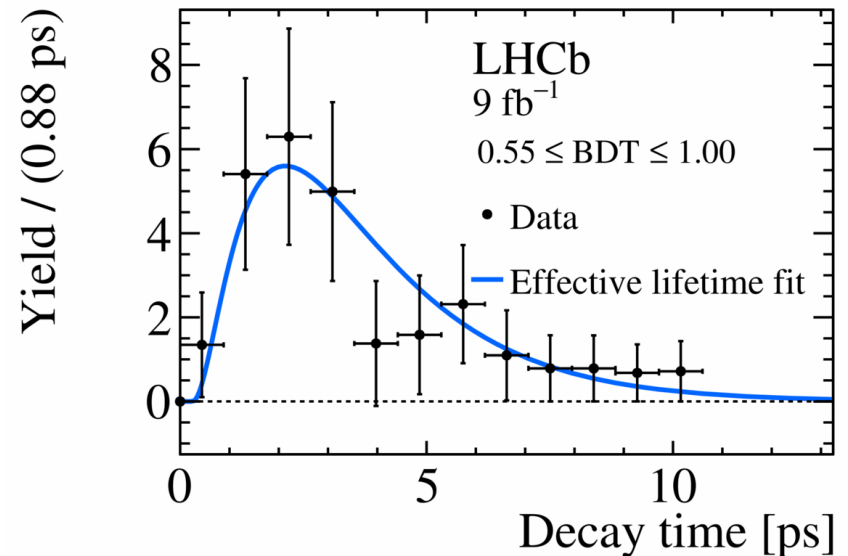

- LHCb measure  $\tau_{\mu^+\mu^-}(B_S(t) \rightarrow \mu^+\mu^-) = (2.07 \pm 0.29 \pm 0.03) \text{ ps}$ .

SM values  $\tau_L = 1.423 \pm 0.005 \text{ ps}$  and  $\tau_H = 1.620 \pm 0.007 \text{ ps}$

Consistency at **2.2 $\sigma$**  and **1.5 $\sigma$**

# Search for $B_{(s)} \rightarrow e^+e^-$

## ■ Standard Model predicts :

Beneke et al. JHEP 10 (2019) 232

- ◆  $\mathcal{B}(B_s \rightarrow e^+e^-) = (8.60 \pm 0.36) \times 10^{-14}$
- ◆  $\mathcal{B}(B^0 \rightarrow e^+e^-) = (2.41 \pm 0.13) \times 10^{-15}$

## ■ CKM and helicity super-suppressed decay : out of reach from the experimental point of view

## ■ LHCb measurement based on Run I and partial Run 2 ( $4 \text{ fb}^{-1}$ ). $\mathcal{B}$ measured relative to $B^+ \rightarrow K^+ J/\psi (\rightarrow e^+e^-)$

- ◆  $\mathcal{B}(B_s \rightarrow e^+e^-) < 9.4 \times 10^{-9} @ 90\%CL$
- ◆  $\mathcal{B}(B^0 \rightarrow e^+e^-) < 2.5 \times 10^{-9} @ 90\%CL$

PRL 124 (2020) 211802

# $b \rightarrow s \ell^+ \ell^-$ transitions

- Study  $B \rightarrow h \mu^+ \mu^-$  transitions with hadron  $h = K, K^*, \phi \dots$
- Same loop diagrams, different spectator quarks
- Rates, angular distributions and asymmetries are sensitive to NP
- A lot of phenomenological work invested in defining observables with “clean” theoretical predictions.

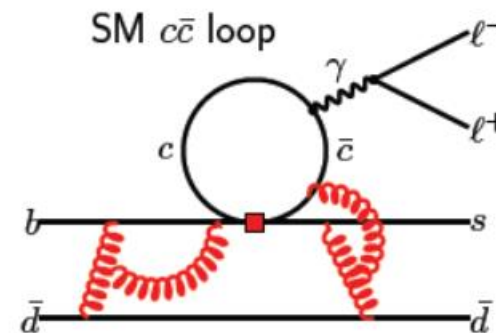
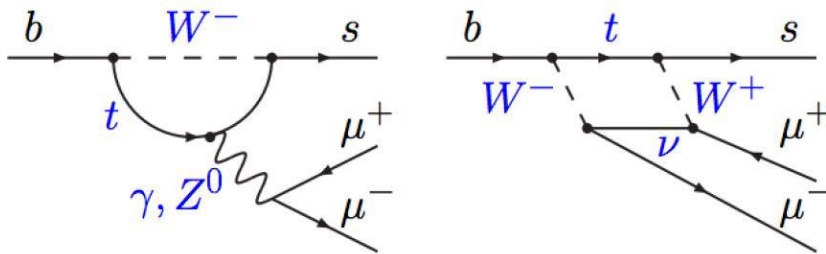

# $B^0 \rightarrow K^{*0} \mu^+ \mu^-$ : 4-body angular observables

- The  $B^0 \rightarrow K^{*0} \mu^+ \mu^-$  differential decay rate can be described by 3 angles and di-muon invariant mass squared ( $q^2$ )
- Rich structure of physics observables in the angular coefficients (as functions of  $q^2$ )
- Form angular coefficients which are robust against form-factor uncertainties (e.g.  $P'_5$ )

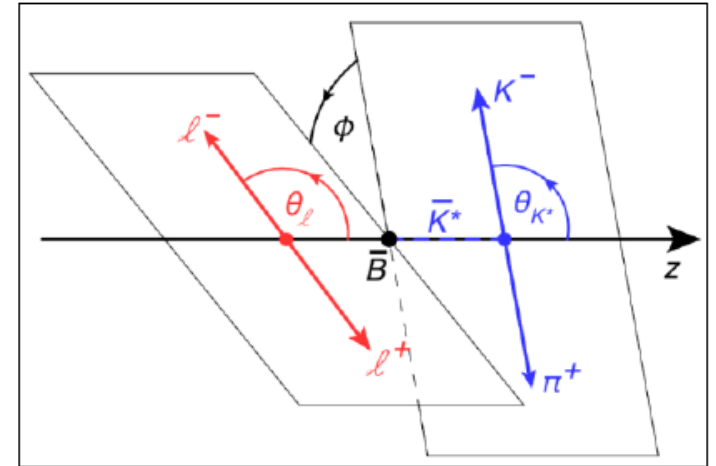

Descotes-Genon et al., JHEP 01 (2013) 048

$$\frac{1}{\Gamma} \frac{d^3(\Gamma + \Gamma)}{d \cos \theta_\ell d \cos \theta_K d\phi} = \frac{9}{32\pi} \left[ \frac{3}{4}(1 - F_L) \sin^2 \theta_K + F_L \cos^2 \theta_K + \frac{1}{4}(1 - F_L) \sin^2 \theta_K \cos 2\theta_\ell \right. \\ \left. - F_L \cos^2 \theta_K \cos 2\theta_\ell + S_3 \sin^2 \theta_K \sin^2 \theta_\ell \cos 2\phi + S_4 \sin 2\theta_K \sin 2\theta_\ell \cos \phi + \right. \\ \left. \sqrt{F_L(1 - F_L)} P'_5 \sin 2\theta_K \sin \theta_\ell \cos \phi + \frac{4}{3} A_{FB} \sin^2 \theta_K \cos \theta_\ell + S_7 \sin 2\theta_K \sin \theta_\ell \sin \phi + \right. \\ \left. S_8 \sin 2\theta_K \sin 2\theta_\ell \sin \phi + S_9 \sin^2 \theta_K \sin^2 \theta_\ell \sin 2\phi \right]$$



# Measurement of $P'_5$ angular coefficient

- Anomaly in  $P'_5$  found in  $B^0 \rightarrow K^{*0} \mu^+ \mu^-$  for  $4 < q^2 < 8 \text{ GeV}^2$
- $P'_5$  local tension of  $2.5\sigma$  and  $2.9\sigma$  in  $q^2$  bins of  $[4.0, 6.0]$  and  $[6.0, 8.0] \text{ GeV}^2$   
→ Global analysis finds a deviation of  $3.3\sigma$
- Also observed also in  $B^+$  isospin partner decay
- Some deviation from SM predictions also in other angular observables
- Results are intriguing, however extent of hadronic contributions still matter of debate (particularly regarding charm-quark loops)

$B^0 \rightarrow K^{*0} \mu^+ \mu^-$

PRL 125 (2020) 011802

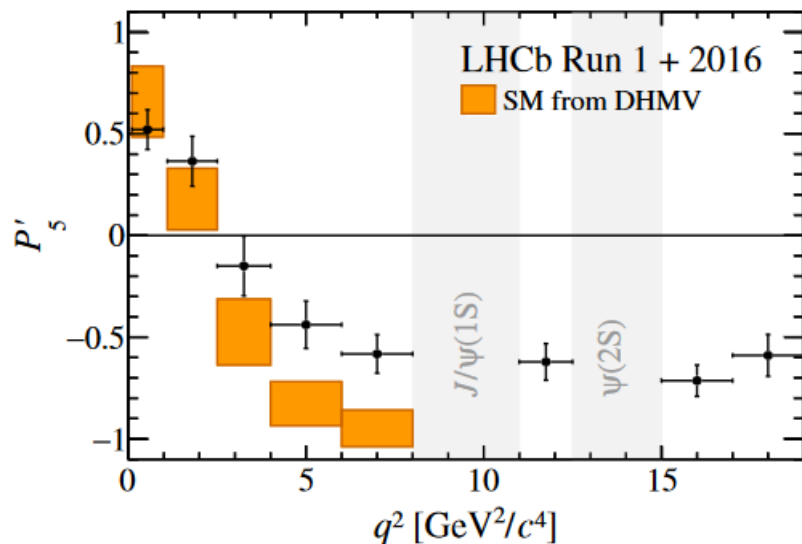

$B^+ \rightarrow K^{*+} \mu^+ \mu^-$

PRL 126 (2021) 161802

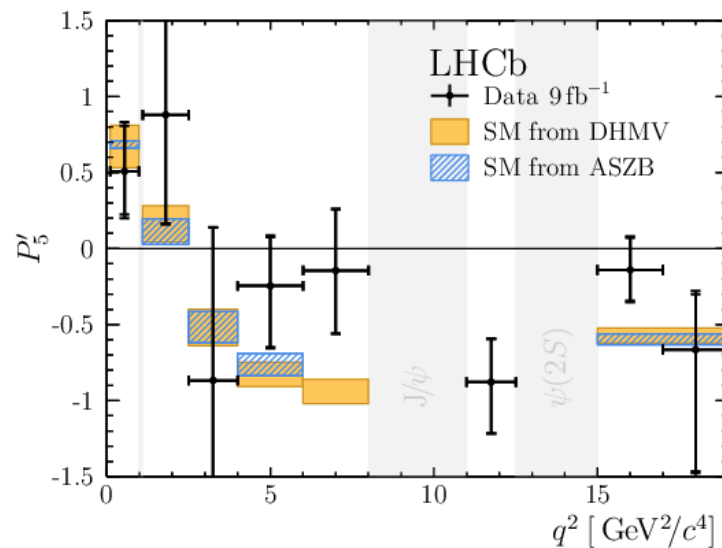

# Semi-leptonic differential branching fractions

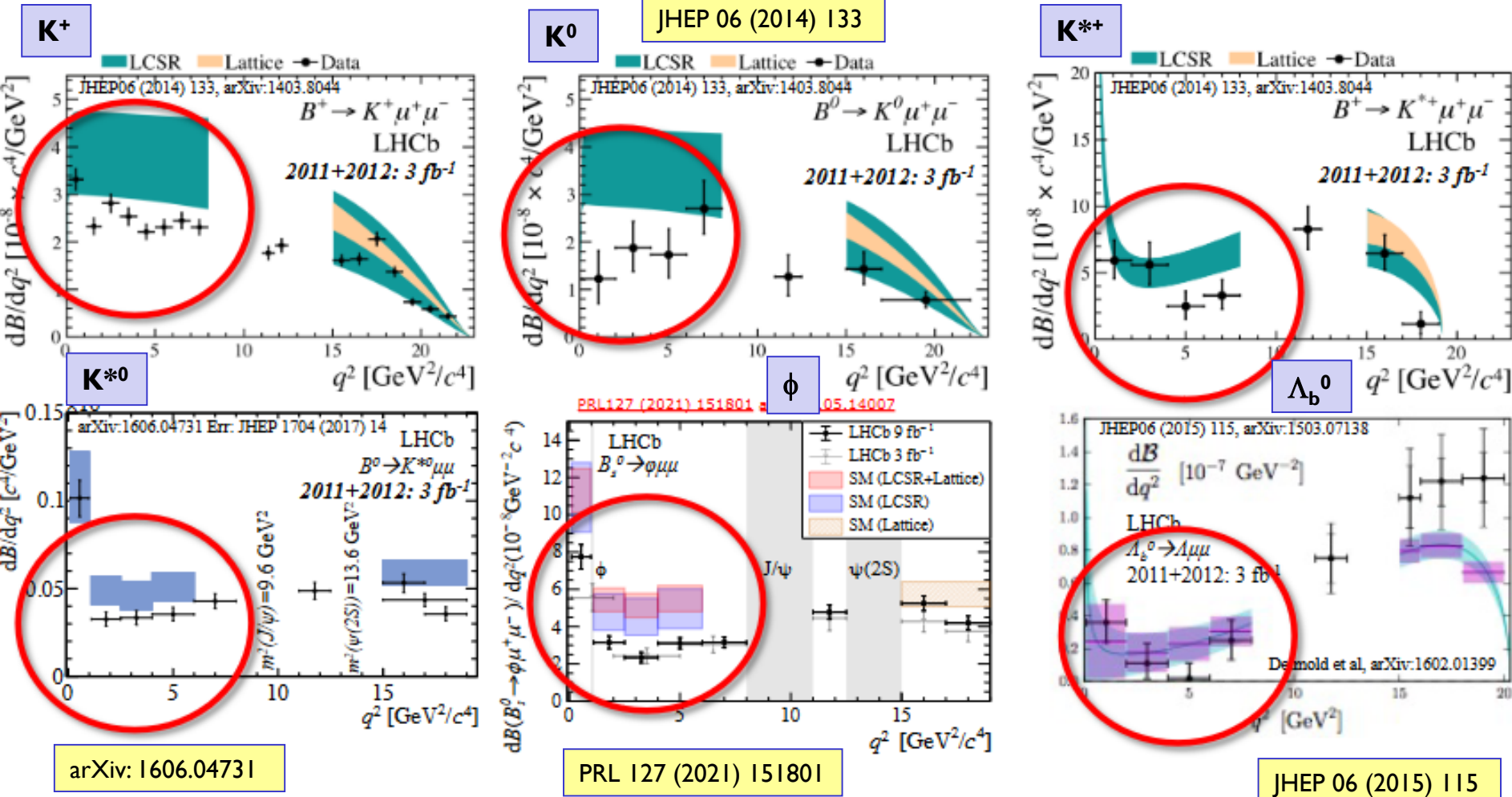

- All semi-leptonic BF's lower than SM expectations at low  $q^2$  ( $\sim 1$  to  $4\sigma$ ) [comparison limited due to large theory uncertainties from form factors]

# Lepton Flavour Universality (LFU)

- LFU is a cornerstone of the SM : charged leptons ( $e, \mu, \tau$ ) couple in a universal way to the SM gauge bosons
- If NP couples in a non-universal way to the three lepton families, then we might see differences in rates of rare decays involving different lepton pairs (e.g.  $e/\mu$  or  $\mu/\tau$ )
- Hence - LFU is tested in  $b \rightarrow s \ell^+ \ell^-$  transitions. These are FCNC's with amplitudes involving loop diagrams

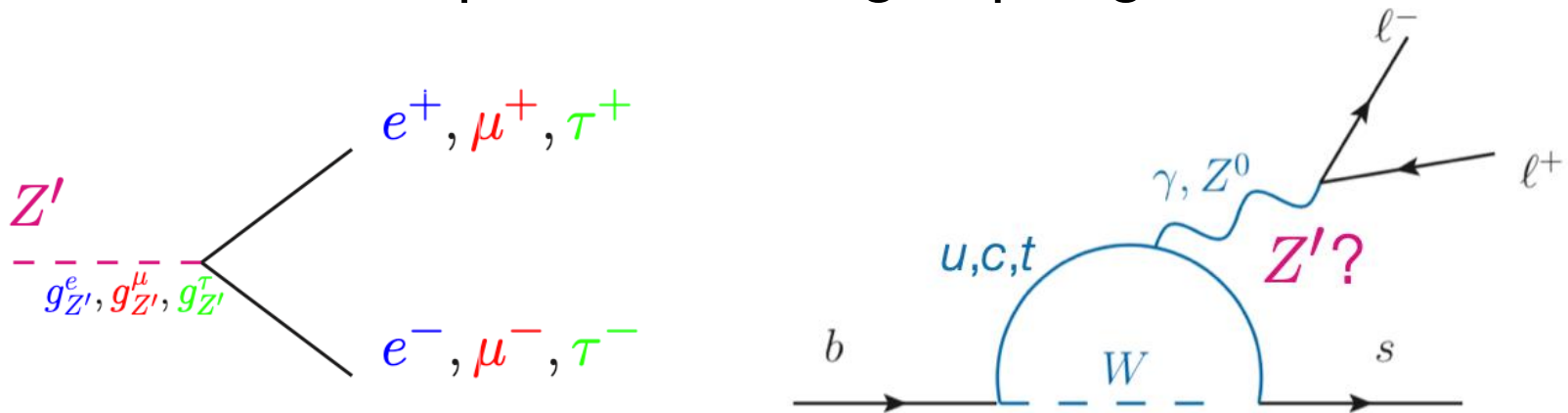

# Several R-ratio measurements

- Compare the rates of  $B \rightarrow X_s e^+ e^-$  and  $B \rightarrow X_s \mu^+ \mu^-$   
[where  $B$  is  $B^+$ ,  $B^0$ ,  $B_s^0$ ,  $\Lambda_b^0$  and  $X_s$  is  $K^+$ ,  $K^{*0}$ ,  $\phi$ ,  $pK \dots$ ]
- This allows precise testing of lepton flavour universality
- We can construct the ratio :

$$R_X = \frac{\int_{q_{\min}^2}^{q_{\max}^2} \frac{d\mathcal{B}(B_q \rightarrow X_s \mu^+ \mu^-)}{dq^2} dq^2}{\int_{q_{\min}^2}^{q_{\max}^2} \frac{d\mathcal{B}(B_q \rightarrow X_s e^+ e^-)}{dq^2} dq^2} = 1 \pm \mathcal{O}(1\%)$$

- Small theoretical uncertainties because hadronic uncertainties cancel
- This ratio is unity in the SM, neglecting lepton masses, with QED corrections at the % level

- Five different ratios published so far by LHCb:  
 $X_s = K^+$ ,  $K_s^0$ ,  $K^{*0}$ ,  $K^{*+}$  and  $pK^-$

# This might seem easy, but actually rather challenging

- Lower efficiency of electron trigger
- Electrons emit bremsstrahlung, resulting in degraded momentum and mass resolution
- Attempt to recover the energy of the emitted photons :
  - ◆ Some energy missed
  - ◆ Some energy mis-attributed

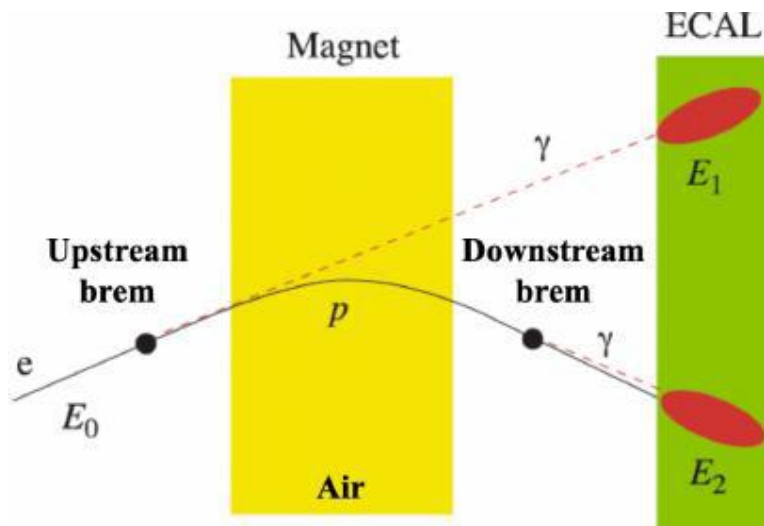

Nat Phys 18 (2022) 277

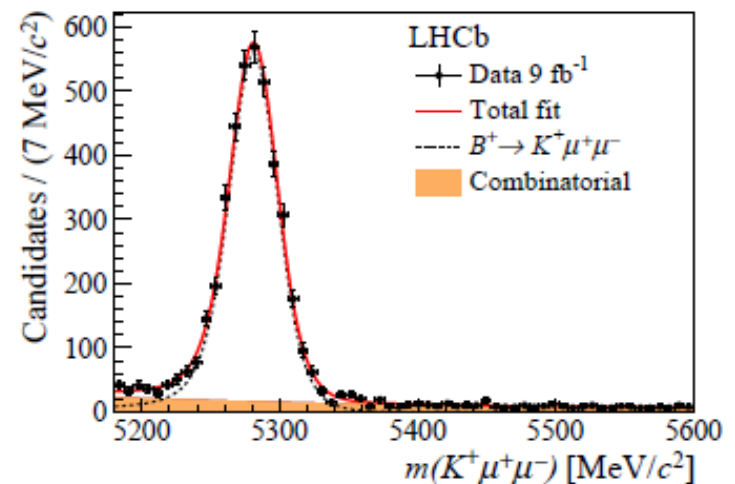
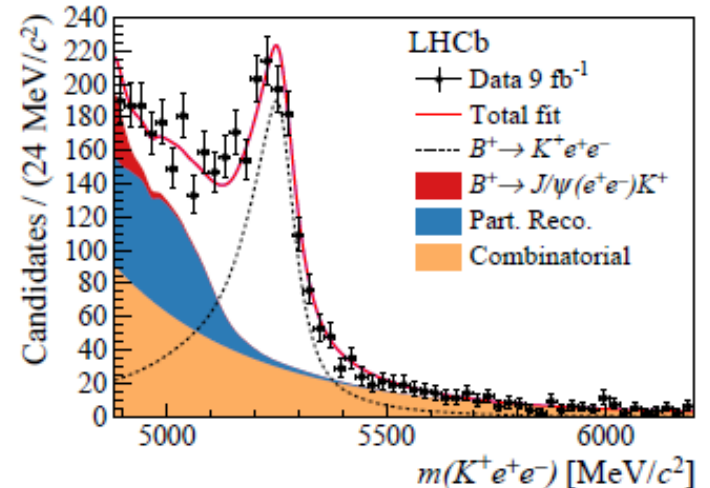

# Experimental strategy

- Actually measure double ratios which significantly reduce systematic uncertainties:

$$R_X = \frac{\mathcal{B}(B_q \rightarrow X_s \mu^+ \mu^-)}{\mathcal{B}(B_q \rightarrow X_s J/\psi(\mu^+ \mu^-))} \cdot \frac{\mathcal{B}(B_q \rightarrow X_s J/\psi(e^+ e^-))}{\mathcal{B}(B_q \rightarrow X_s e^+ e^-)}$$

- Ratios determined using yields and efficiencies
  - ◆ Yields extracted from fits to the data
  - ◆ As cross-checks the ratios

$$R_{J/\psi} = \frac{\mathcal{B}(B_q \rightarrow X_s J/\psi(\mu^+ \mu^-))}{\mathcal{B}(B_q \rightarrow X_s J/\psi(e^+ e^-))}$$

are compatible with unity to 0.4%

$X_s$	$\Gamma_{J/\psi}$	$R_{\psi(2S)}$
$K^+$	$0.981 \pm 0.020$	$0.997 \pm 0.011$
$K^{*+}$	$0.965 \pm 0.032$	$1.017 \pm 0.050$
$K_s^0$	$0.977 \pm 0.028$	$1.014 \pm 0.036$
$K^0$	$1.043 \pm 0.045$	within $1\sigma$ from 1
$pK^-$	$0.96 \pm 0.05$	within $1\sigma$ from 1

# LFU results : $R_x$

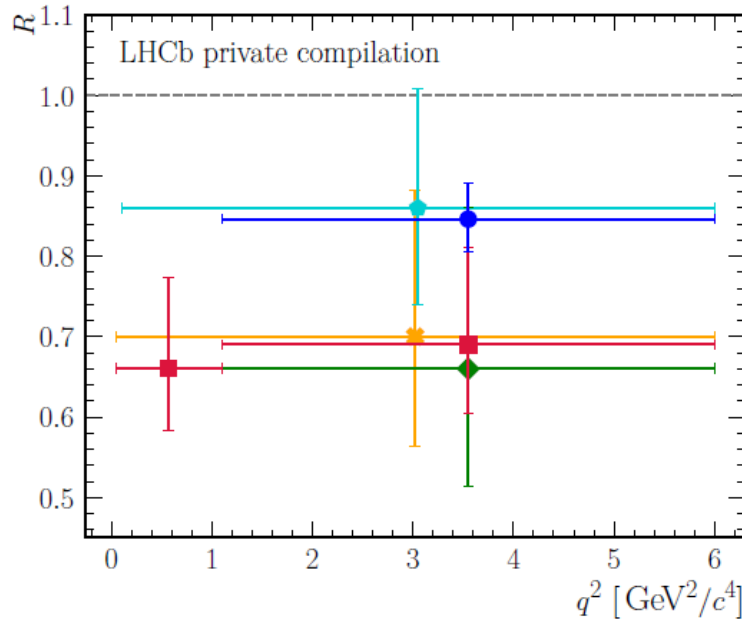
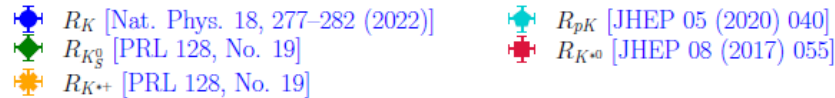

$R_K$  (9/fb) 3.1  $\sigma$  from SM

$R_{K^{*+}}$  (9/fb) 1.4  $\sigma$  **NEW**

$R_{K_S^0}$  (9/fb) 1.5  $\sigma$  **NEW**

$R_{K^{*0}}$  low- $q^2$  (3/fb) 2.1  $\sigma$

$R_{K^{*0}}$  central- $q^2$  (3/fb) 2.4  $\sigma$

$R_{pK}$  (5/fb) < 1  $\sigma$

- All measurements have values less than unity
- The puzzle persists → we eagerly await Belle-II & CMS results
- LHCb is now focused on completing a combined analysis of RK & RK\* with the Run I+2 dataset. This work has led to a deeper understanding of systematics which will be reflected in the final result.



# LFU studies in $B^0 \rightarrow D^{(*)-}\tau^+\nu_\tau$ decays

- Different class of decays (**tree-level** charged current with  $V_{cb}$  suppression)
- Not at all rare:  $B(B^0 \rightarrow D^{*-}\tau^+\nu_\tau) \sim 1\%$ , the problem is the background.
- Lepton-universality ratio  $R(D^*)$ :

$$R(D^*) = \frac{B(B^0 \rightarrow D^{*-}\tau^+\nu_\tau)}{B(B^0 \rightarrow D^{*-}\mu^+\nu_\mu)}$$

- may be sensitive to any NP model coupling preferentially to third generation leptons

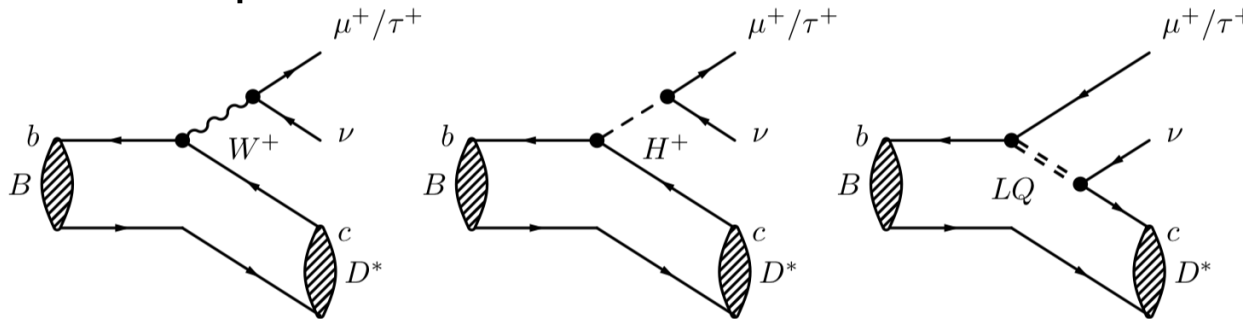

- Ratios predicted theoretically at  $\sim 1\%$ :

$$R(D)_{\text{SM}} = 0.299 \pm 0.003$$

$$R(D^*)_{\text{SM}} = 0.258 \pm 0.005$$

HFLAV 2019 average  
of theoretical  
predictions

- Anomalies first observed by Belle and BaBar

# $R(D)$ vs $R(D^*)$

- All experiments see an excess wrt SM predictions
- Combining  $R(D)/R(D^*)$  average  $\sim 3.4 \sigma$  tension with SM

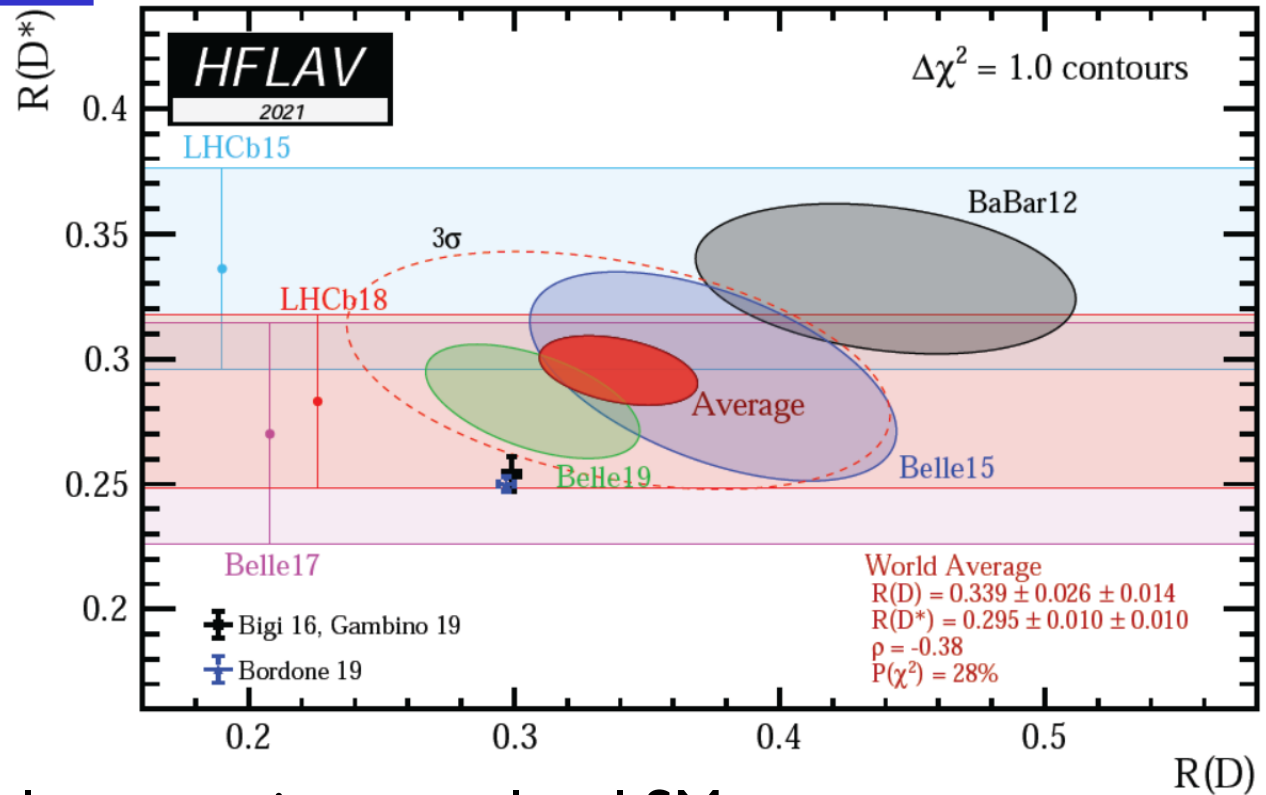

- Intriguing as anomaly occurs in a tree-level SM process
- New LHCb result

$$R(\mathcal{A}_c) = 0.242 \pm 0.026 \pm 0.040 \pm 0.059(\text{ext})$$

arxiv:2201:03497

Measurement is consistent with SM ( $\sim 1 \sigma$  “low”) [SM= $0.324 \pm 0.004$ ].

# The upgraded LHCb detector and outlook

# LHCb Upgrade planning



WE ARE  
HERE

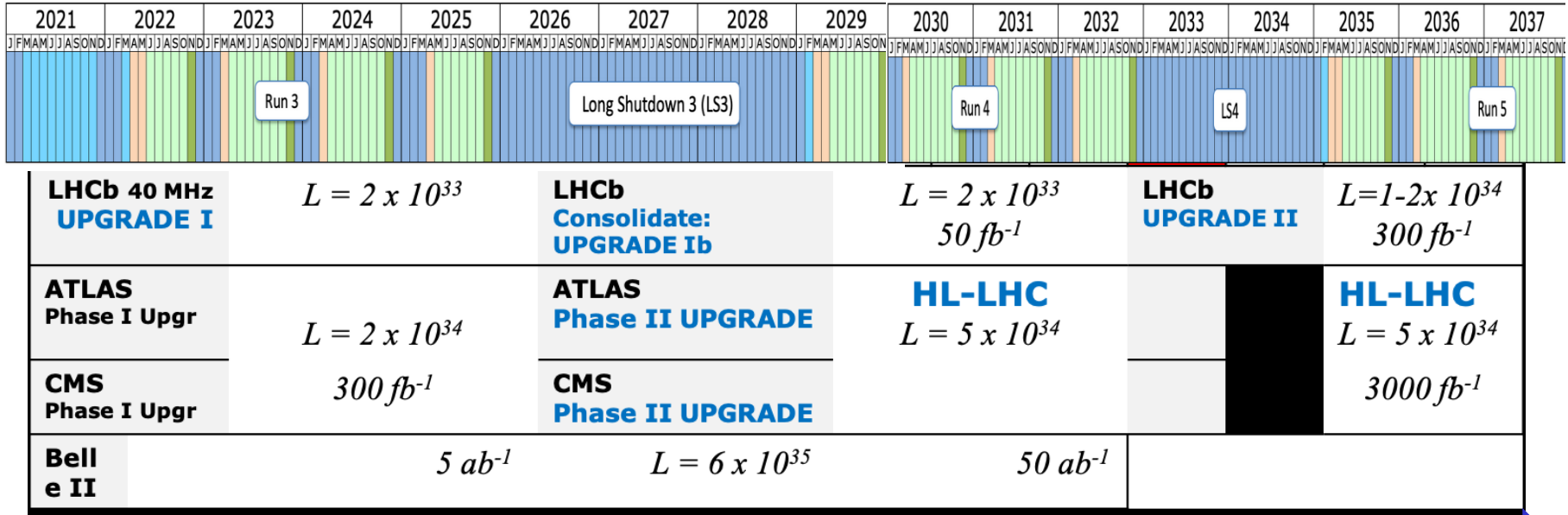

Luminosity  $4 \times 10^{32} \text{ cm}^{-2}\text{s}^{-1}$   
 ~1.1 visible interactions/crossing  
 ~9  $\text{fb}^{-1}$  collected

Luminosity  $2 \times 10^{33} \text{ cm}^{-2}\text{s}^{-1}$   
 ~5.5 visible interactions/crossing  
 Up to 50  $\text{fb}^{-1}$  collected

Luminosity  $2 \times 10^{34} \text{ cm}^{-2}\text{s}^{-1}$   
 ~55 visible interactions/crossing  
 300  $\text{fb}^{-1}$  collected

# LHCb Upgrade I

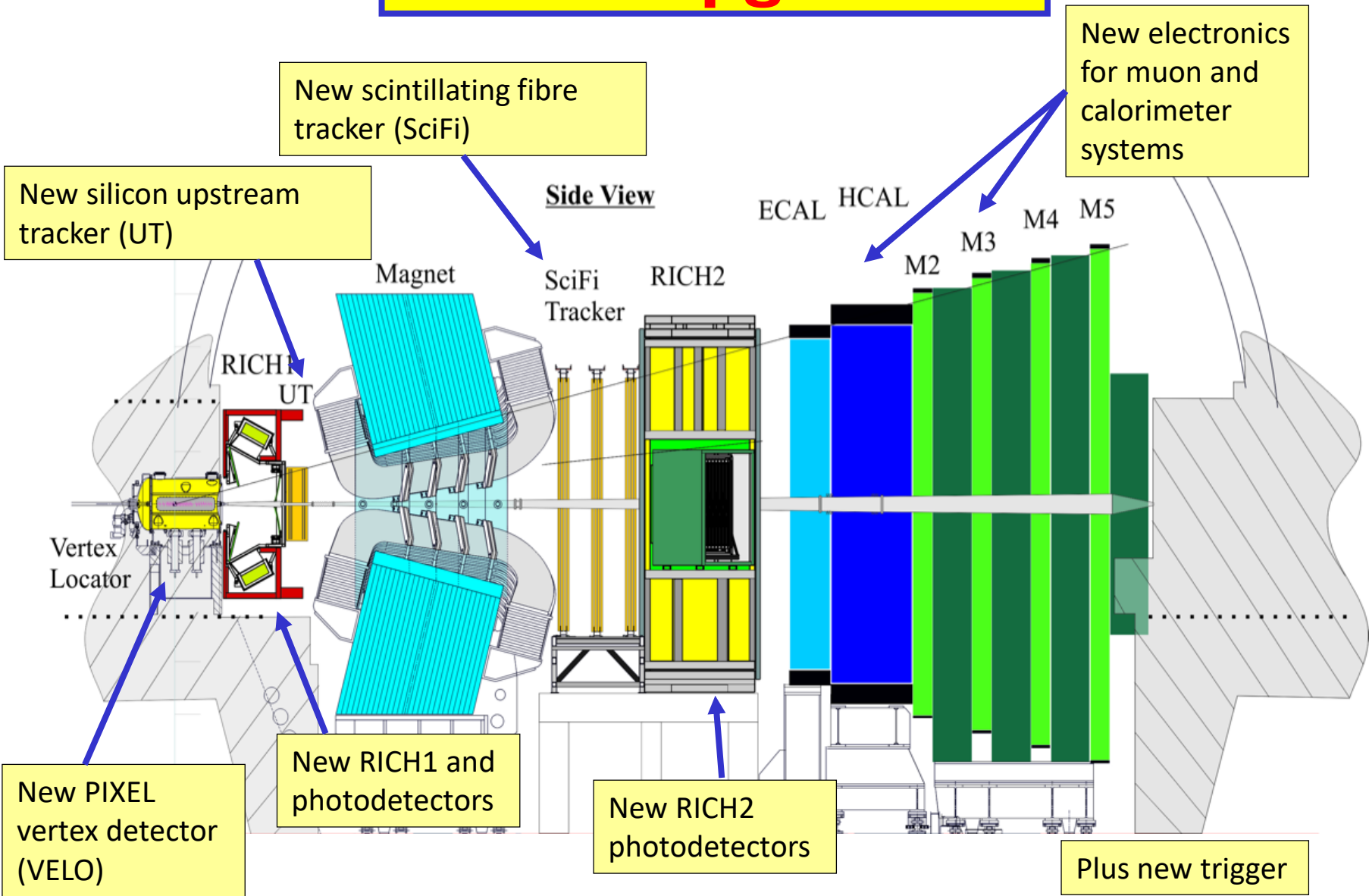

New silicon upstream tracker (UT)

New scintillating fibre tracker (SciFi)

New electronics for muon and calorimeter systems

New PIXEL vertex detector (VELO)

New RICH1 and photodetectors

New RICH2 photodetectors

Plus new trigger



# Construction & Installation – Upgrade I

SciFi tracker

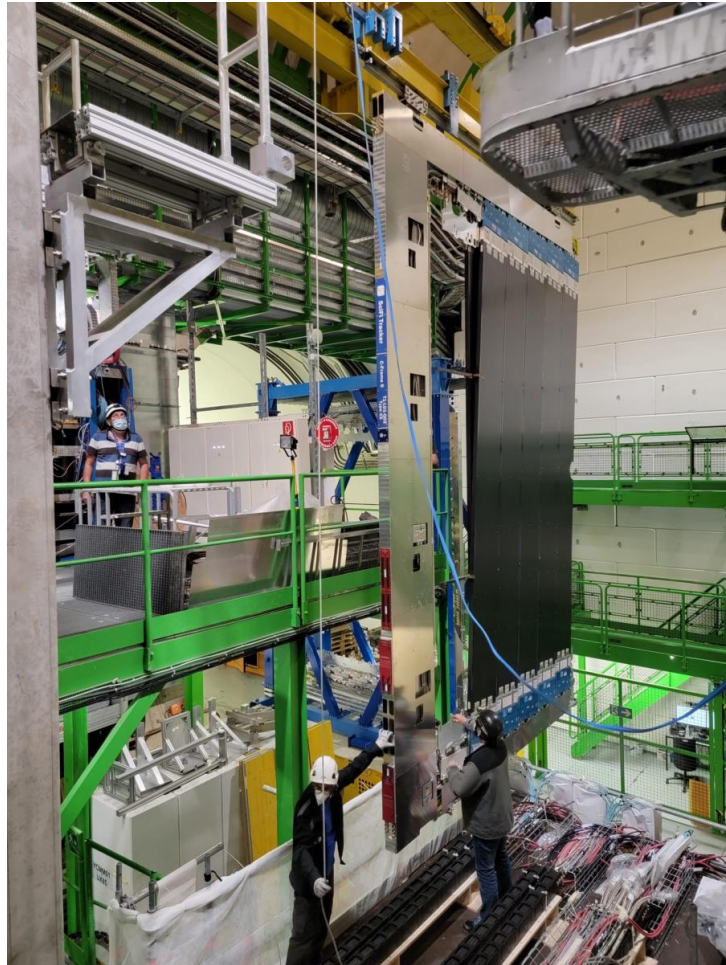

Corfu Summer Institute

RICH 2



UT stave

N. Harnew

# July 5<sup>th</sup> 2022 - 16:47

DETECTOR LATEST POSTS

## First collisions at the world-record energy for a brand-new LHCb detector

JUL 5, 2022 ADMIN

Start of LHC Run 3. Today, at 16:47, protons collided again at LHCb after a 3.5 year break known as Long Shutdown 2 (LS2). During...

LHCb Integrated Luminosity in p-p in 2022

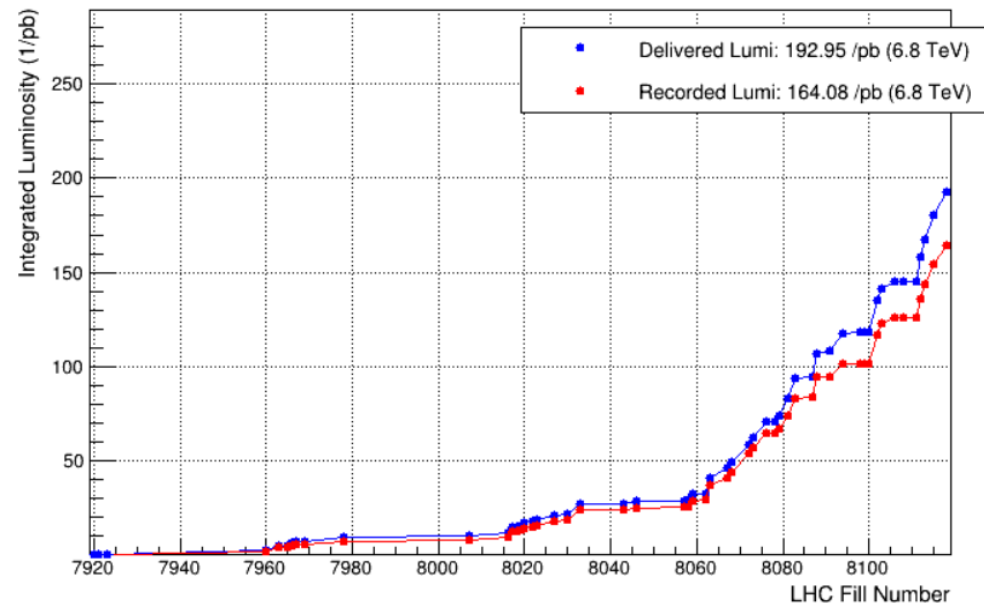



# $\gamma$ prospects : Run II $\rightarrow$ Upgrade I

- Post Run II target of  $4^\circ$  almost surpassed ( $\sim 9 \text{ fb}^{-1}$ ) and analyses still in progress



- LHCb Upgrade I : target  $0.9^\circ$  ( $\sim 50 \text{ fb}^{-1}$ )

$$\gamma = (65.4^{+3.8}_{-4.2})^\circ$$

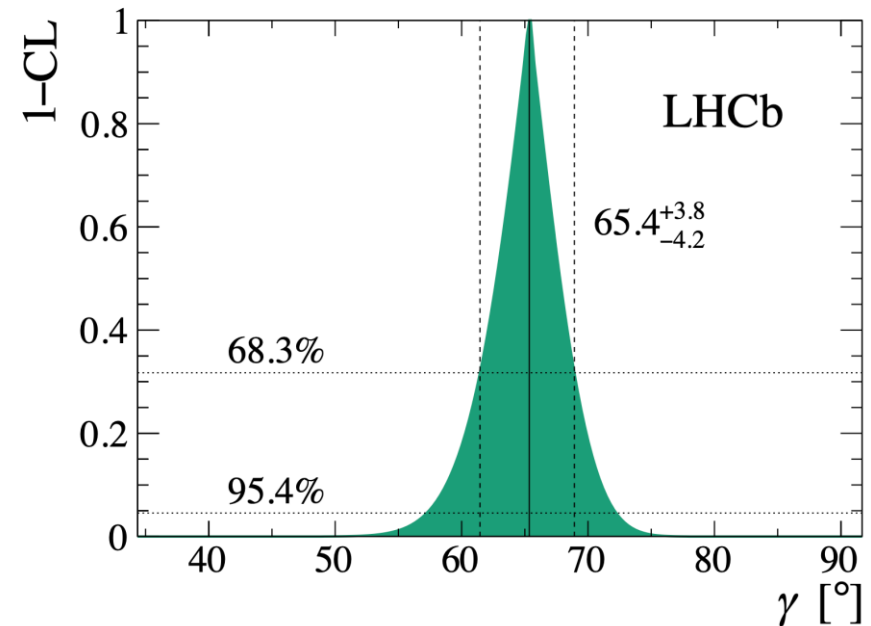

EPJC (2013) 73:2373

# ... and beyond 2035 : Upgrade II

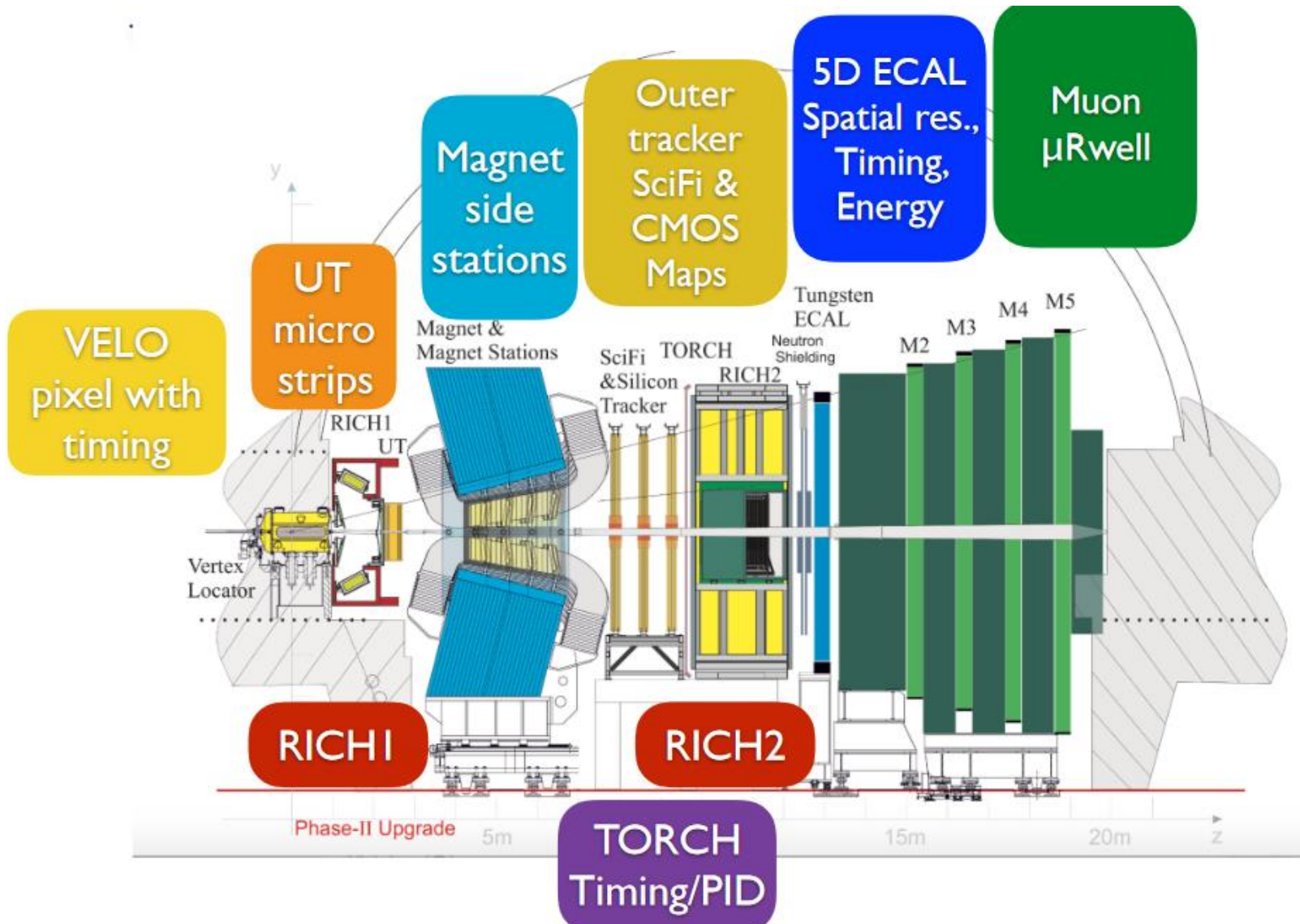

# Evolution of the Unitarity Triangle

LHCb : 2021  
Run 2 ( $\sim 9 \text{ fb}^{-1}$ )

LHCb-PUB-2018-009

LHCb Upgrade I  
2025 ( $\sim 23 \text{ fb}^{-1}$ )

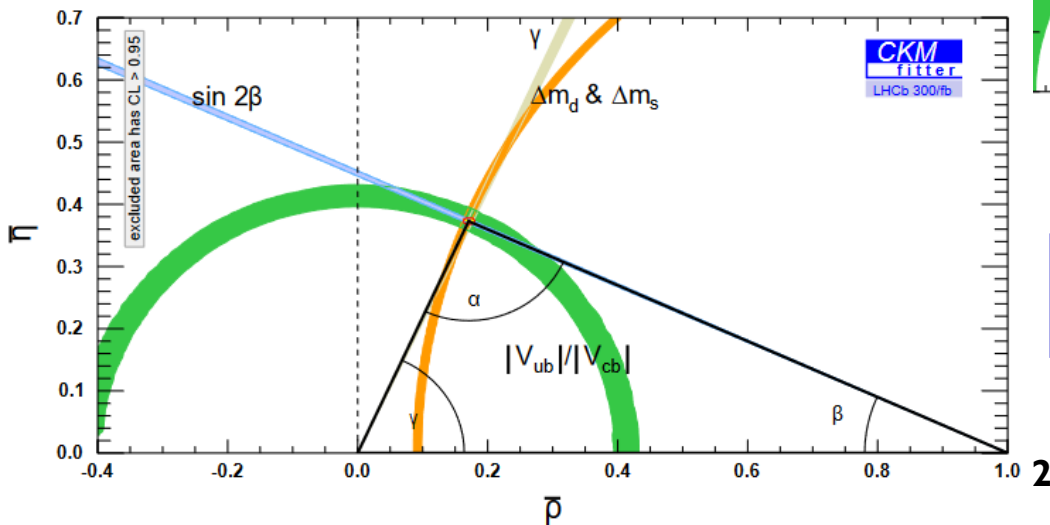
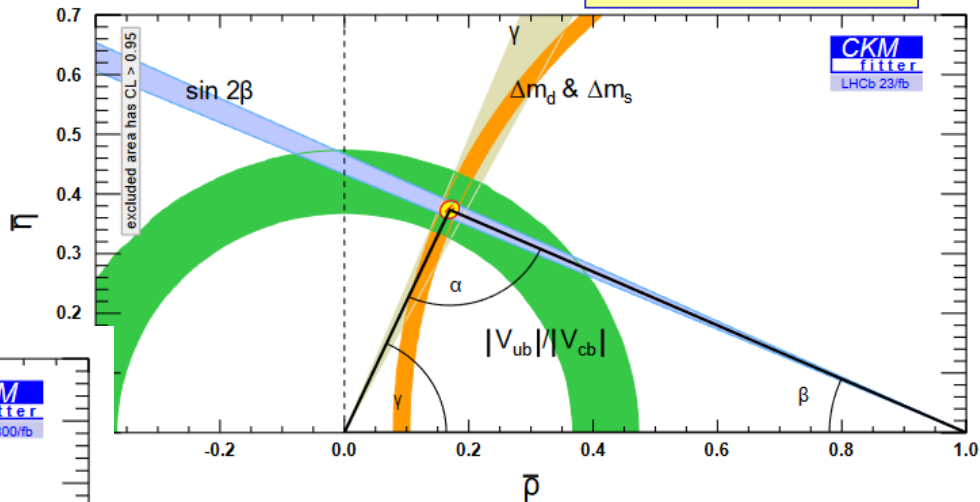
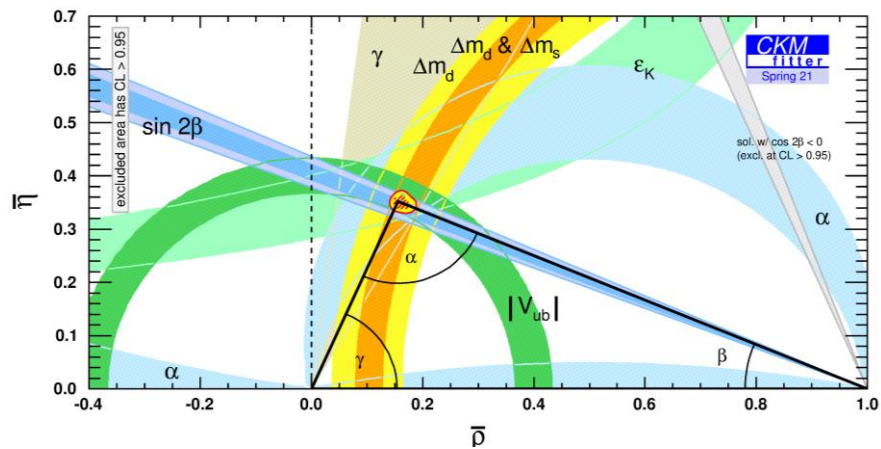

LHCb Upgrade II  
2035 ( $300 \text{ fb}^{-1}$ )

# Summary and Outlook

- The LHCb experiment has performed spectacularly well :  
→  $\sim 9 \text{ fb}^{-1}$  of recorded data up to  $\sqrt{s} = 13 \text{ TeV}$
- So far all Unitarity Triangle measurements are consistent with the Standard Model  
→ New Physics is becoming constrained
- LHCb is a fantastic platform for spectroscopy measurements: many measurements were never foreseen in LHCb's original physics portfolio. We now even need a new naming system !
- Many rare-decay results show good compatibility with the SM, however hints of LFU violation persist. This has generated a lot of theoretical interest. We eagerly await confirmation ...
- Still a lot of room for New Physics, but higher precision required  
→ preparing for LHCb Upgrades beyond 2022 and the decade afterwards! Very much looking forward to Belle-II results.