

GEM Detectors for CMS Experiment

Michele Bianco

(CERN Geneva, Switzerland)

Detector Seminar

July 8th, 2022

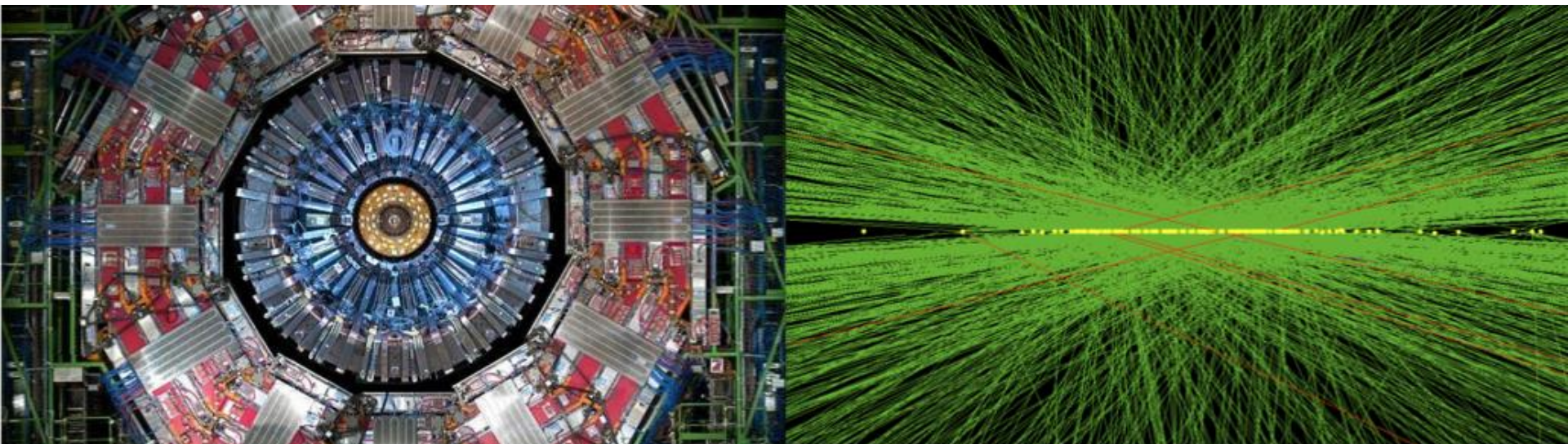

Thanks to CMS GEM group!!!

Special mention to:

A. Sharma, F. Fallavollita, R. De Oliveira, J. A. Merlin, A. Safonov, G. De Lentdecker, M. Hohlmann P. Verwilligen, A. Colaleo, M. Maggi, A. Cardini, M. Abbas, A. Garcia Conde, S. Brachet, G. Mocellin, I. Vai, P. Everaerts, A. Pellecchia, T. Kamon, F. M. Simone, E. Oliveri, L. Ropelewski, D. Fiorina, F. Ivone, J. Jaramillo Gallego, L. Ramirez Garcia, N. Rosi, S. Kim, J.P. Chatelain, M. Van Stainse,

Thanks to the organizers for the invitation!!!

- The CMS Muon System
- CMS Forward Muon Spectrometer Upgrade
- The GEM Technology & the GEM for CMS
- GE1/1 project
 - R&D, The Slice Test, Detector Production, Electronic Integration, Installation, Commissioning, Lesson learnt, Physics (coming soon)
- GE2/1 project
 - How to implement what learned with GE1/1: Status and plan
- ME0 project
 - New challenges for GEM detectors
 - Ongoing R&D
- Summary

Highly hermetic and redundant muon system, at least four stations on a muon path in all directions

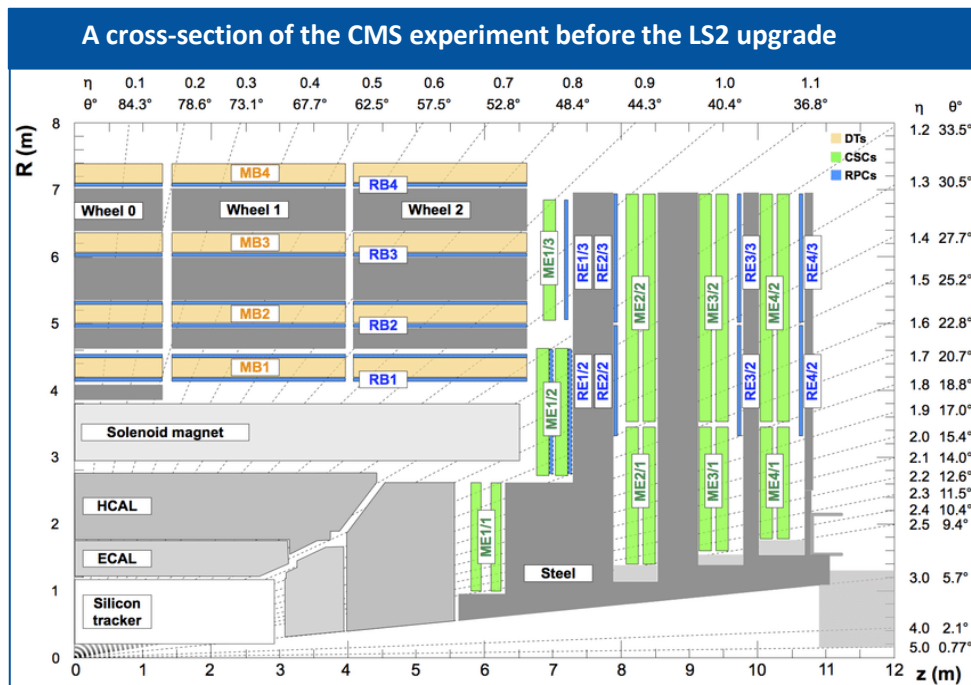

3 technologies:

- ◆ **Drift Tubes** and **Cathode Strip Chambers** (for tracking and triggering);
- ◆ **Resistive Plate Chambers** (for triggering).

Eta coverage:

- ◆ $|\eta| < 1.6$: 4 layers of CSCs and RPCs, DTs
- ◆ the $|\eta| \geq 1.6$: CSCs only;

GOALS:

- ◆ **robust, redundant and fast identification of the muons**
- ◆ **Level-1 trigger** has access to muon information only
- ◆ **Momentum measurement:** the muon system is relevant for high pt muon (>100 GeV) and in the high η region (large lever arm of the muon system)

LHC / HL-LHC Plan

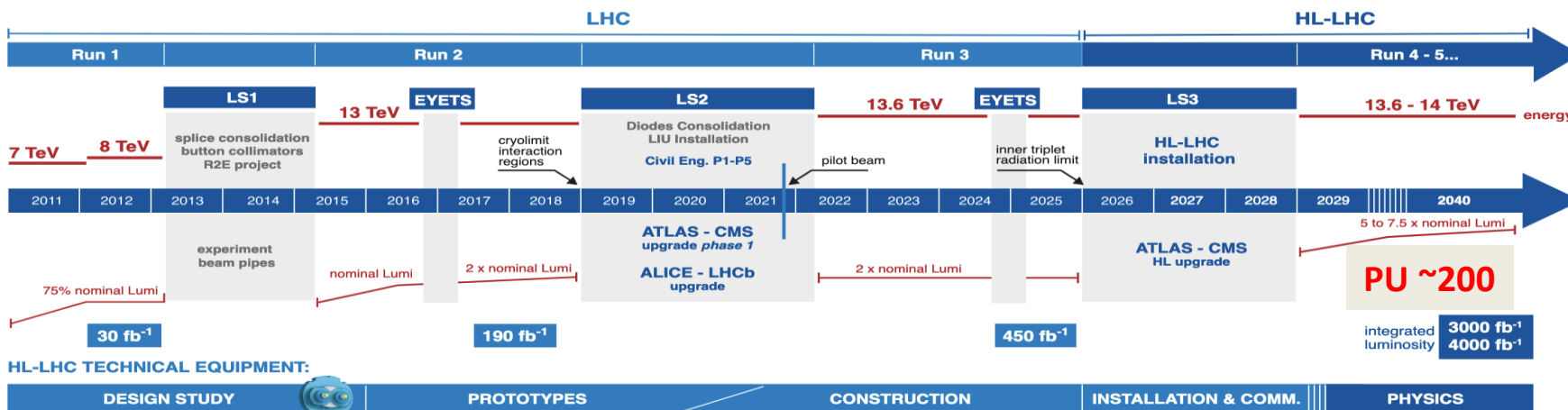

Goal: keep the same performance as in Phase-1

CMS Upgrades

- New tracker (4 pixel layers +3 disks)
- New trigger/DAQ:
 - Track information at L1 with extended trigger latency (total of 12.5 μ s)
 - Increased L1 bandwidth to 750 kHz
- Calorimeters with higher granularity
- **Upgrade of Muon system**

}

$|\eta| < 3$

Maintain standalone trigger and reconstruction, mitigation of efficiency loss due to aging of the current detectors can be met if:

- the number of hits recorded is sufficiently large
- spatial accuracy and the time resolution are very good.
- good momentum measurement for the rejection of unwanted soft muons, mis-measured as high p_T muons \rightarrow prevent increase in p_T threshold

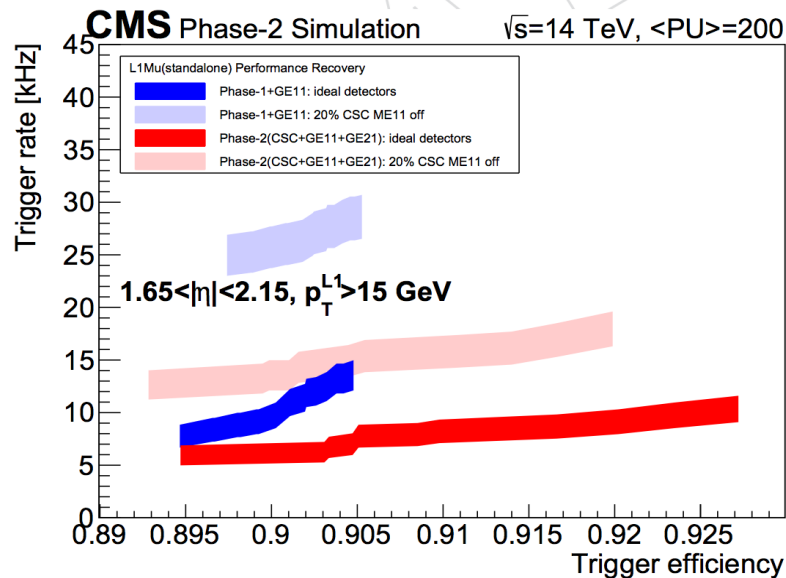
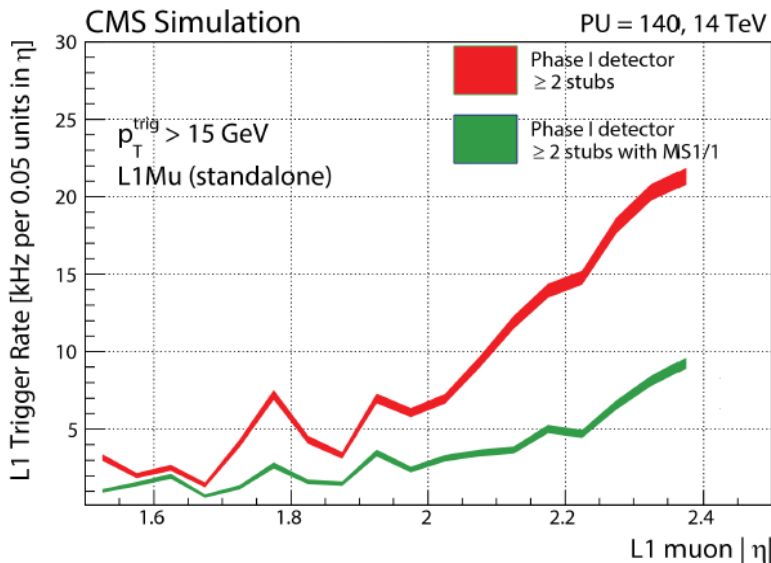
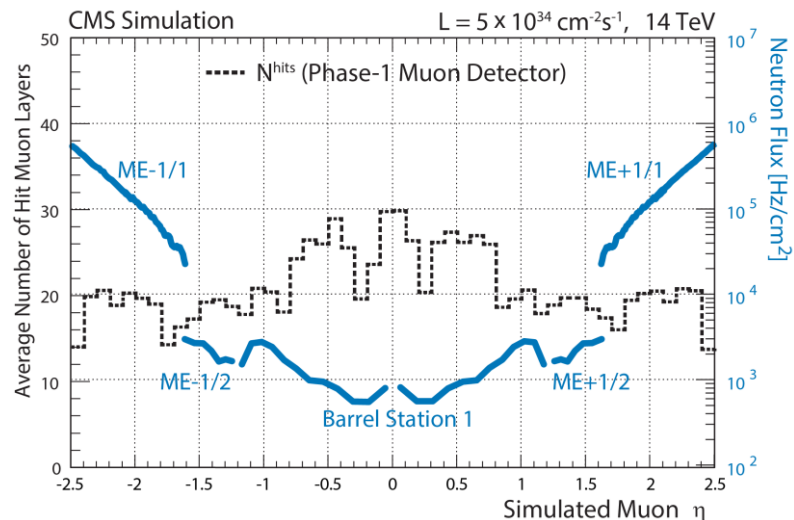

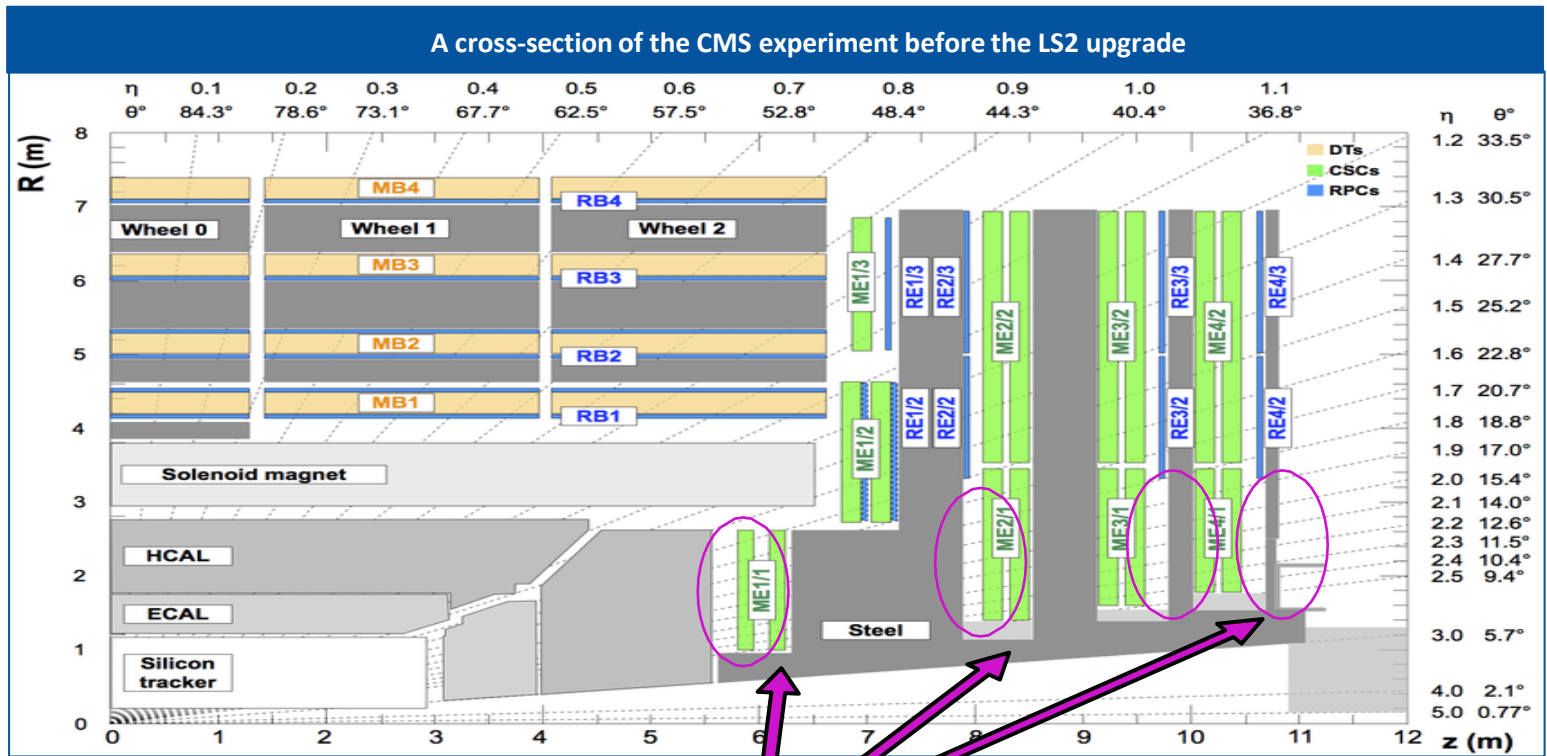

Space is available in the endcaps and additional space will be created with the new CMS Nose!

- ➔ Possibility to insert additional detection layers in order to provide a better selection/measurement of the muons and to add redundancy to maintain the CMS performance in case of failure

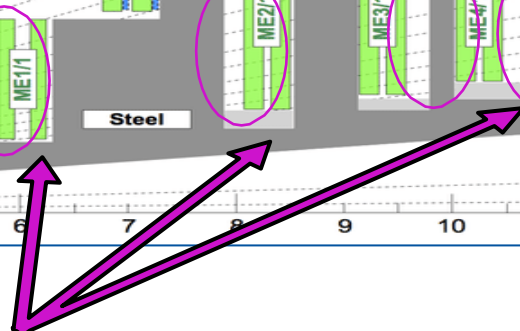

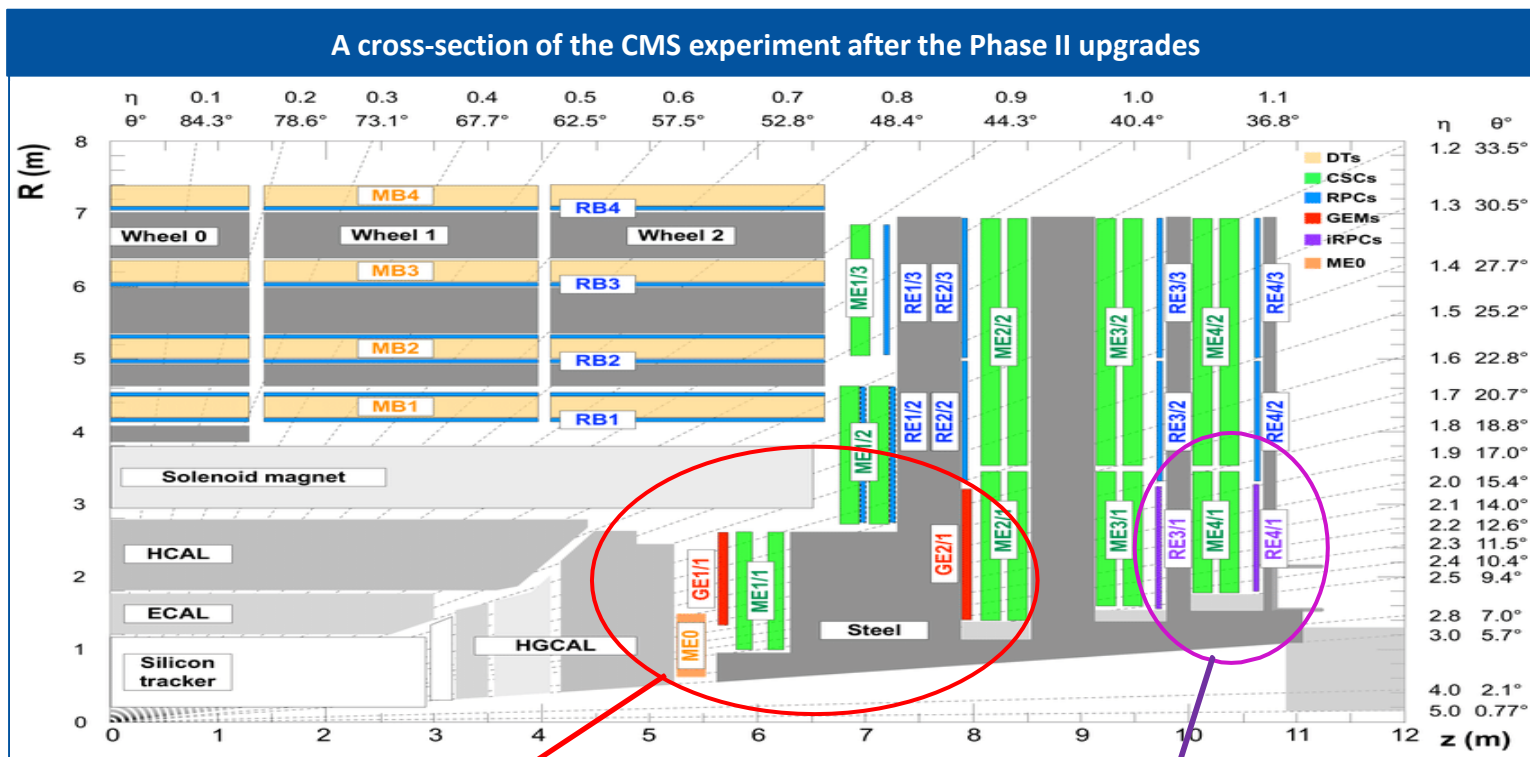

The GEM upgrade: three new stations GE1/1, GE2/1 and ME0 based on the triple-GEM technology

The RPC upgrade: two new stations RE3/1 and RE4/1 based on the improved-RPC technology

GE1/1

Till LS2, forward trigger for $|\eta| > 1.6$ relies entirely on the CSC system (ME1/1) **strong B field**

GEM detector in front of CSC can measure muon bending angle in magnetic field and add redundancy

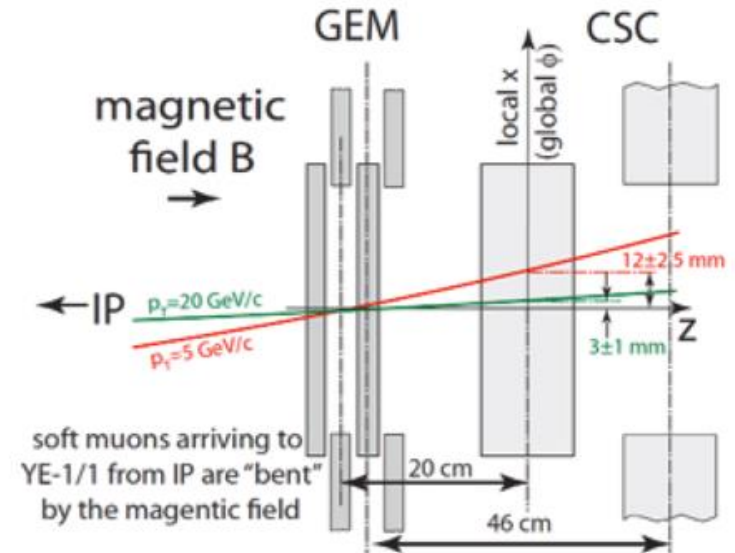
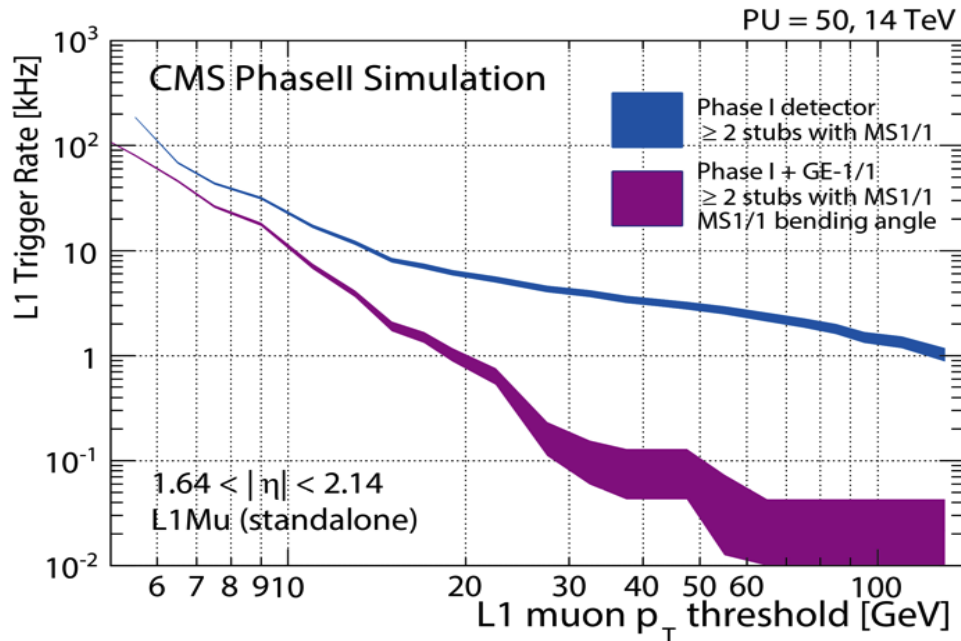

maintain 15 GeV online threshold, keep < 5 kHz rate, high efficiency

How GEMs will help

GE1/1 + GE2/1

CONCEPT
(axial view)

CSCs alone provide short segments with low-precision info on segment direction

● *CSC segments*

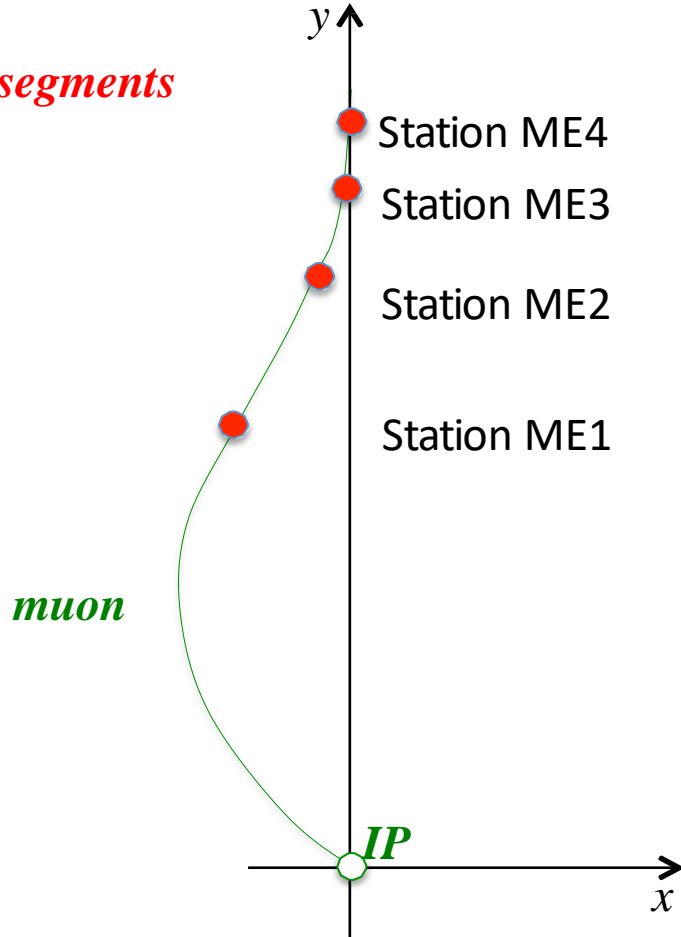

How GEMs will help

GE1/1 + GE2/1

CONCEPT
(axial view)

● *CSC segments*
/ *CSC-GEM segments*

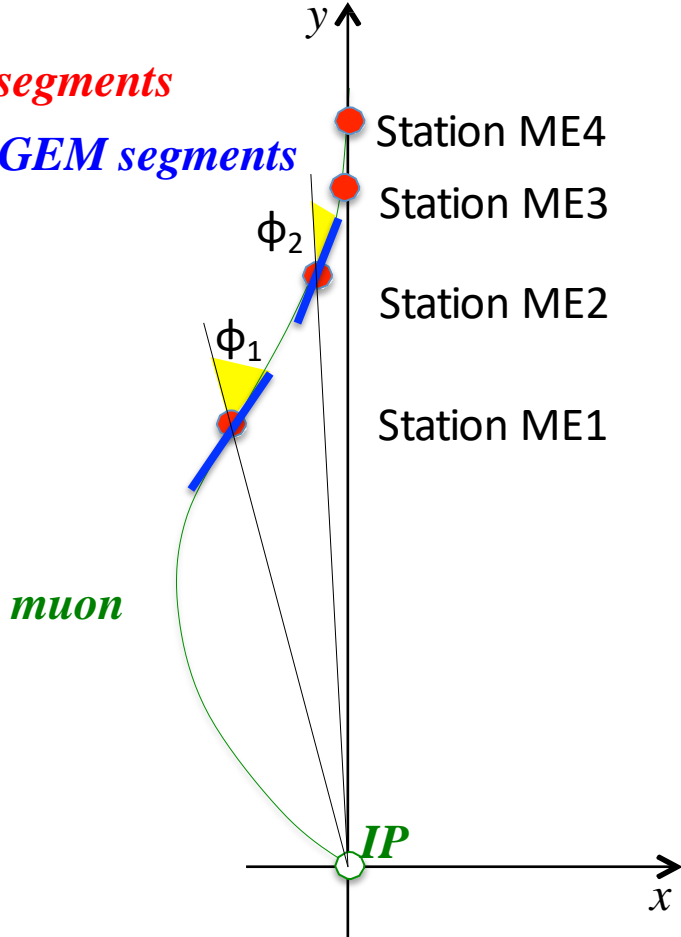

CSCs alone provide short segments with low-precision info on segment direction

GEM-CSC tandems in ME1 and ME2 stations give accurate measurement of muon "local" direction sensitive to muon p_T

GE1/1 + GE2/1

CONCEPT
(axial view)

● *CSC segments*

▬ *CSC-GEM segments*

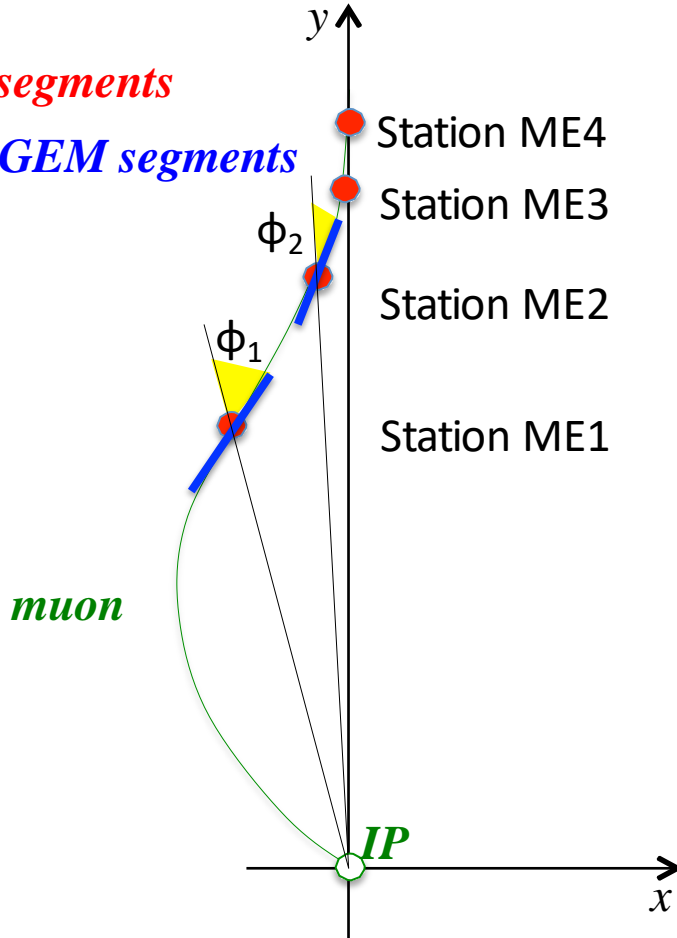

CSCs alone provide short segments with low-precision info on segment direction

GEM-CSC tandems in ME1 and ME2 station give accurate measurement of muon “local” direction sensitive to muon p_T

p_T measurement improves and, hence, the standalone L1-trigger rate drops

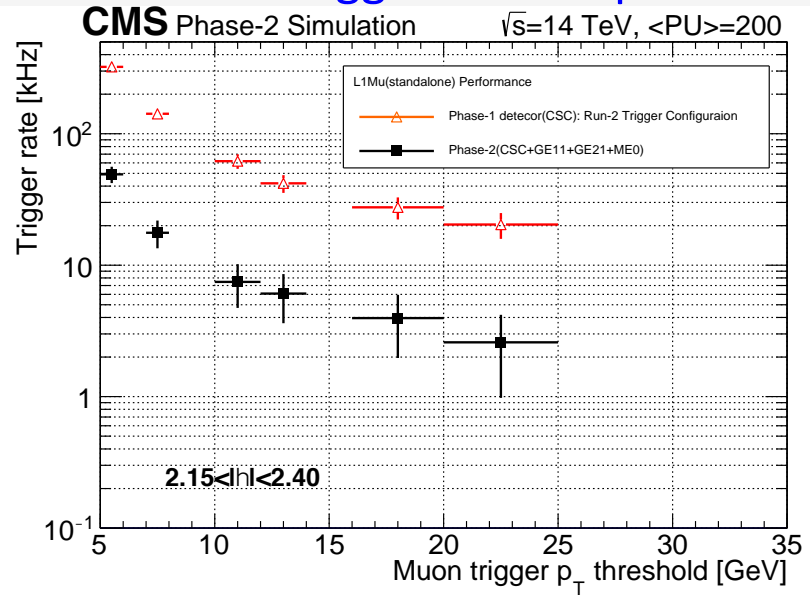

How GEMs will help

ME0

- ME0 will increase the acceptance of CMS Muon System up to $|\eta| = 2.8$, will provide a muon trigger signal in the very forward region, and the ME0 hits will be used in the offline muon reconstruction
- The ME0 chambers partially overlap (up to $|\eta| = 2.4$) with the existing CSC endcap muon chambers
- The ME0 detector extends the muon acceptance into the pseudorapidity range $2.4 < |\eta| < 2.8$, which is beyond the reach of any other CMS muon detector. The increased muon acceptance is fully covered by the new Phase-2 inner silicon tracker
- Each ME0 detector consists of six layers of triple-GEM chambers, compared to the two-layer design of GE1/1 and GE2/1

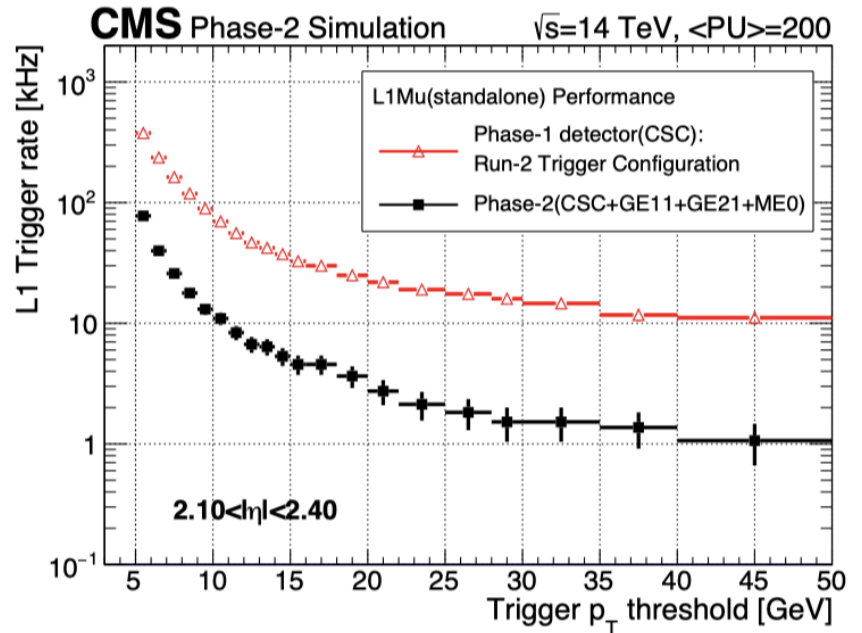
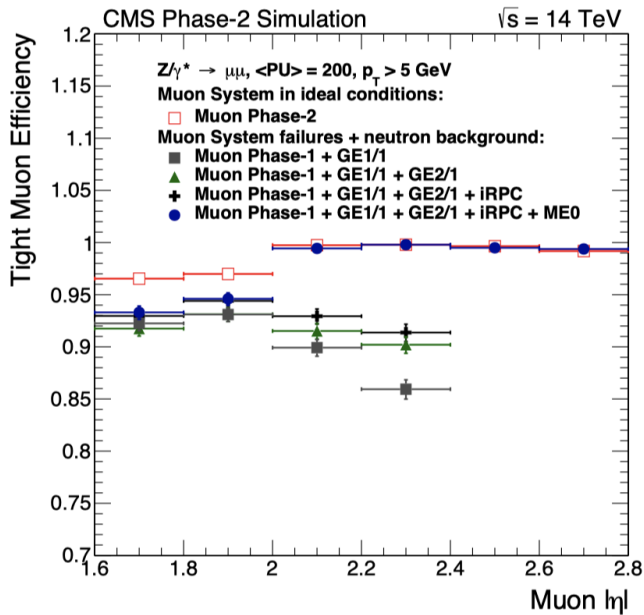

THE GAS ELECTRON MULTIPLIER (GEM):

100 μm PITCH HOLES ON COPPER-CLAD POLYIMIDE FOIL

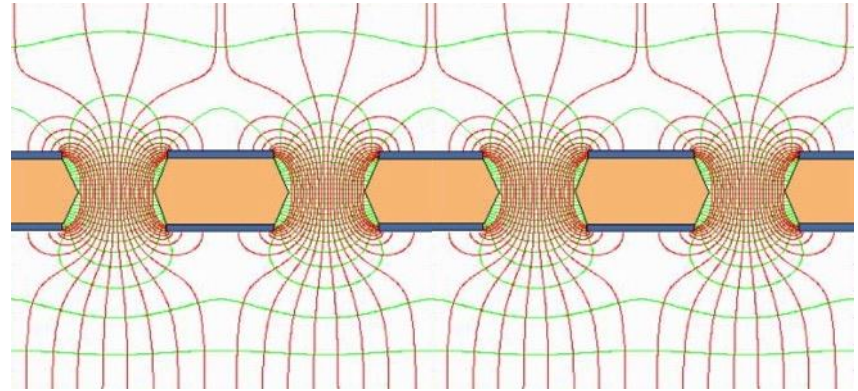
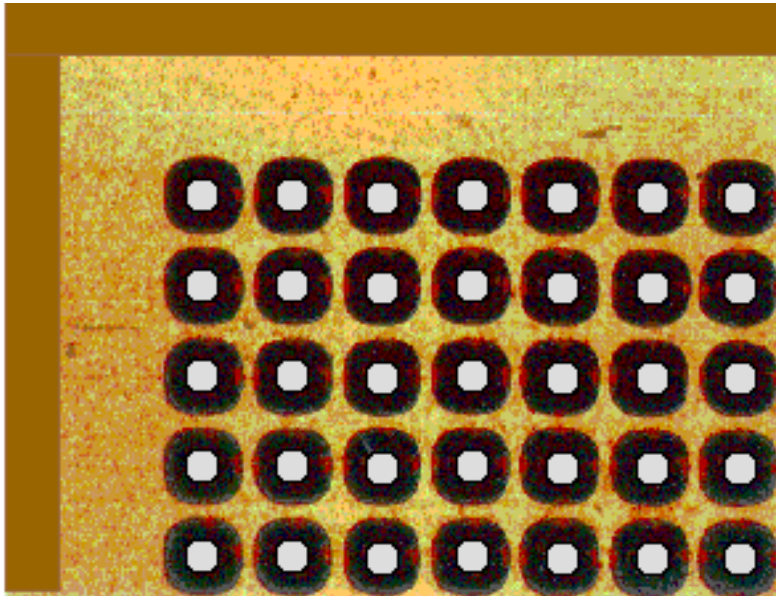

PRESENTED AT:
 IEEE Nuclear Science Symposium & Medical
 Imaging Conference
 Anaheim, CA November 3-9, 1996

F. Sauli, Nucl. Instr. and Meth. A386(1997)531

- Concept of Gas Electron Multipliers

- Gas Electron Multipliers (GEM) was introduced by **Fabio Sauli** in 1996-97
- Gas Electron Multiplier electrode is a thin polymer foil, metal-coated on both sides and pierced with a high density of holes, typically $50\text{--}100\text{ mm}^{-2}$
- Inserted between a drift and a charge collection electrode, and with the application of appropriate potentials, the GEM electrode develops near the holes equipotential field lines
- The large difference of potential applied between the two sides of the foil creates a high field in the holes; electrons released in the upper region drift towards the holes and acquire sufficient energy to cause ionizing collisions with the molecules of the gas filling the structure
- A sizeable fraction of the electrons produced in the avalanche's front leave the multiplication region and transfer into the lower section of the structure, where they can be collected by an electrode, or injected into a second multiplying region, schematically a single GEM detector, with a two-dimensional patterned charge detection anode

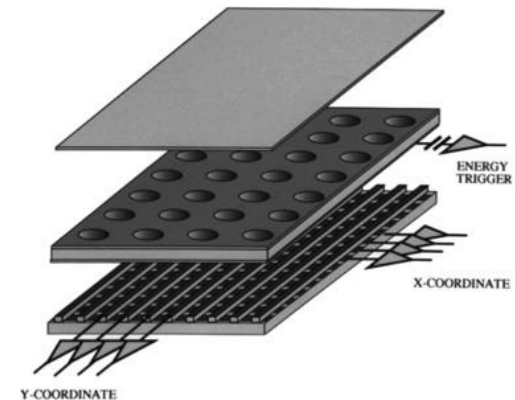
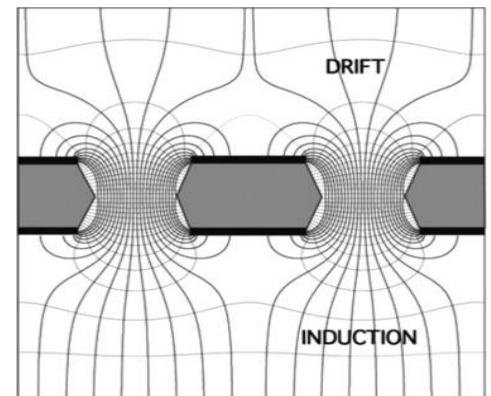
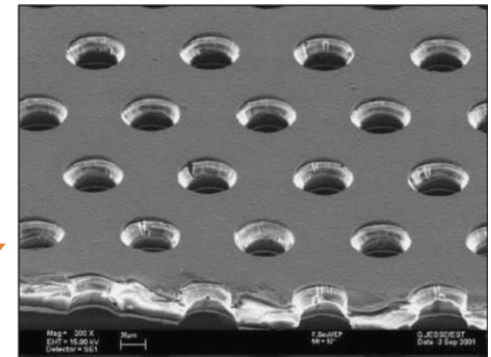

What are the GEM

Gas Electron Multipliers

SEM picture of a GEM

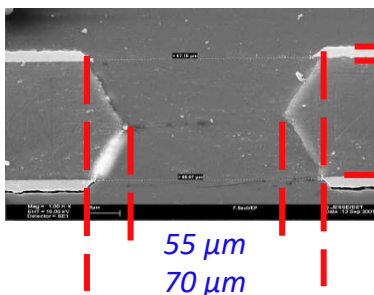
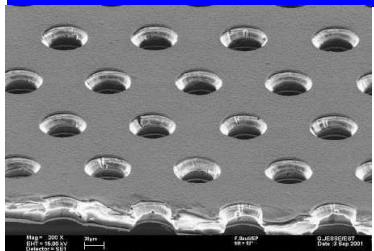

5 μm

50 μm

55 μm
70 μm



SEM picture of a GEM hole

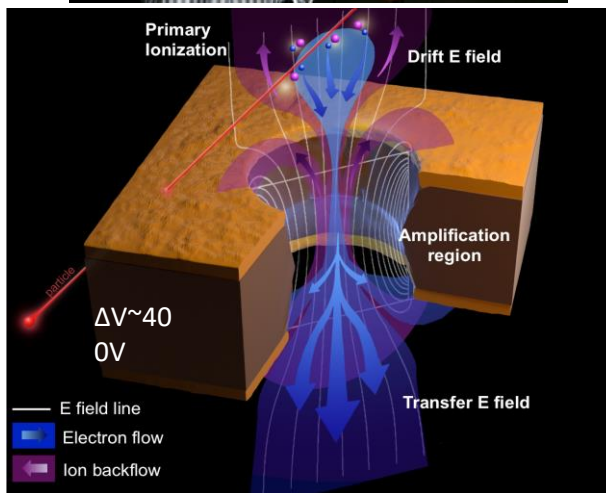
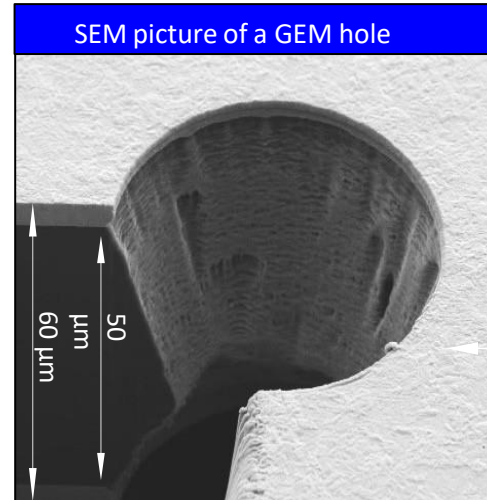

Electrons entering the GEM holes will accelerate in the intense electric field (~80 kV/cm) and provoke the ionization of gas molecules, giving rise to an electron avalanche

Multiplication: 1 e⁻ input to > 1000 e⁻ output (as a function of gas and HV)

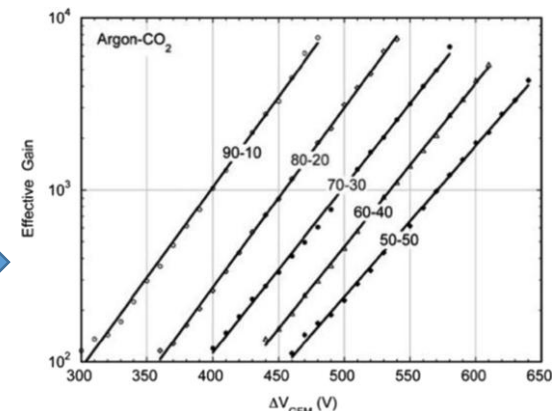

Master of GEM

CERN's Printed Circuit Workshop



Mastering GEM

GEM production technique evolved along the time from double to single mask technique

• Double mask



• Same base material

• Hole patterning in Cu

• Polyimide etch

• Bottom electro etch

• Second Polyimide Etch

- Limited to ~ 100cm x 40cm due to
 - Mask precision and alignment
 - Lithography/Production machine

Pro

Fast Production (automatization, reduced manpower)

Cons

Very expensive setup (tools and glass mask)

• Single mask

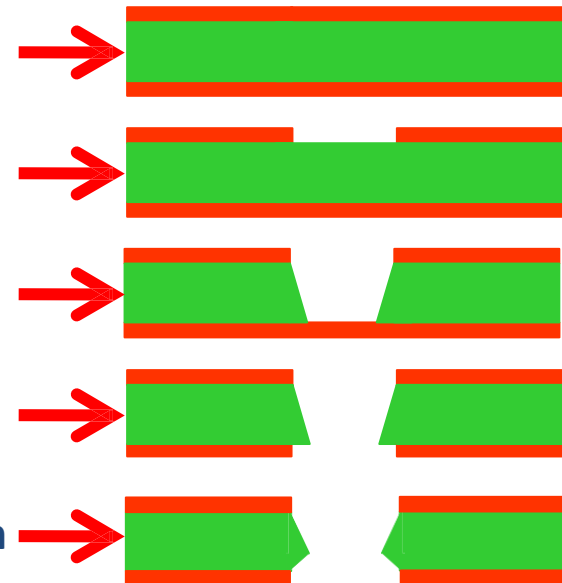

- Limited to 2m x 60cm due to
 - Base material
 - Equipment (size bath for photolithography process)

Pro

Cheap mask (fundamental for R&D)

Cons

High intensity human labour

I'll not discuss the genesis of the GEM as technology for particle identification and their possible multiple applications, only the GEM for CMS Experiment

Some interesting references for those who want to broaden the horizon:

- F. Sauli, *The gas electron multiplier (GEM): Operating principles and applications*, NIM A, 386 (1997), p. 531
- S. Bachmann, *et al. Charge amplification and transfer processes in the gas electron multiplier* NIM A, 438 (1999), p. 376
- A. Bressan, *et al. Two-dimensional readout of GEM detectors* NIM A, 425 (1999), p. 254
- A. Bondar, *et al. Study of ion feedback in multi-GEM structures*, NIM A, 496 (2003), p. 325
- M. Villa, *et al. Progress on large area GEMs* NIM A, 628 (2011), p. 182
- H. Fenker, *et al. BoNus: Development and use of a radial TPC using cylindrical GEMs* NIM A, 592 (2008), p. 273
- A. Balla, *et al. Construction and test of the cylindrical-GEM detectors for the KLOE-2 Inner Tracker* NIM A, 732 (2013), p. 221
- P. Everaerts, *Rate capability and ion feedback in GEM detectors (Thesis at Gent University)* (2006)
- F. Sauli, *GEM readout of the time projection chamber* CERN-EP-TA1 Internal Report (1999)
- L. Fabbietti, *et al. The PANDA GEM-based TPC prototype* NIM A, 628 (2011), p. 204
- ALICE_Collaboration, *Technical Design Report for the Alice Time Projection Chamber*, 2014.
- Va'vra, A. Sharma *Single electron detection in quadruple-GEM detector with pad readout* NIM A, 478 (2002), p. 235
- R. Bellazzini, *et al. Imaging with the invisible light* NIM, 581 (2007), p. 246
- J.A. Mir, *et al. Further studies on the gain properties of a Gas Electron Multiplier with a Micro-Induction Gap Amplifying Structure (GEM-MIGAS) aimed at low-energy X-ray detection* NIM A, 580 (2007), p. 1372
- A. Bondar, *et al. Two-phase argon and xenon avalanche detectors based on Gas Electron Multipliers* NIM A, 556 (2006), p. 273
- Murtas, F. *The GEMPix Detector*, <https://doi.org/10.1016/j.radmeas.2020.106421>
- Leidner, J.; Murtas, F.; Silari, M. *Medical Applications of the GEMPix*. Appl. Sci. 2021,11, 440. <https://doi.org/10.3390/app11010440>
- Leidner, J., Ciocca, M., Mairani, A., Murtas, F. and Silari, M. *A GEMPix-based integrated system for measurements of 3D dose distributions in water for carbon ion scanning beam radiotherapy*. (2020) Med. Phys., 47: 2516-2525. <https://doi.org/10.1002/mp.14119>
-

Timescale of GEM in CMS

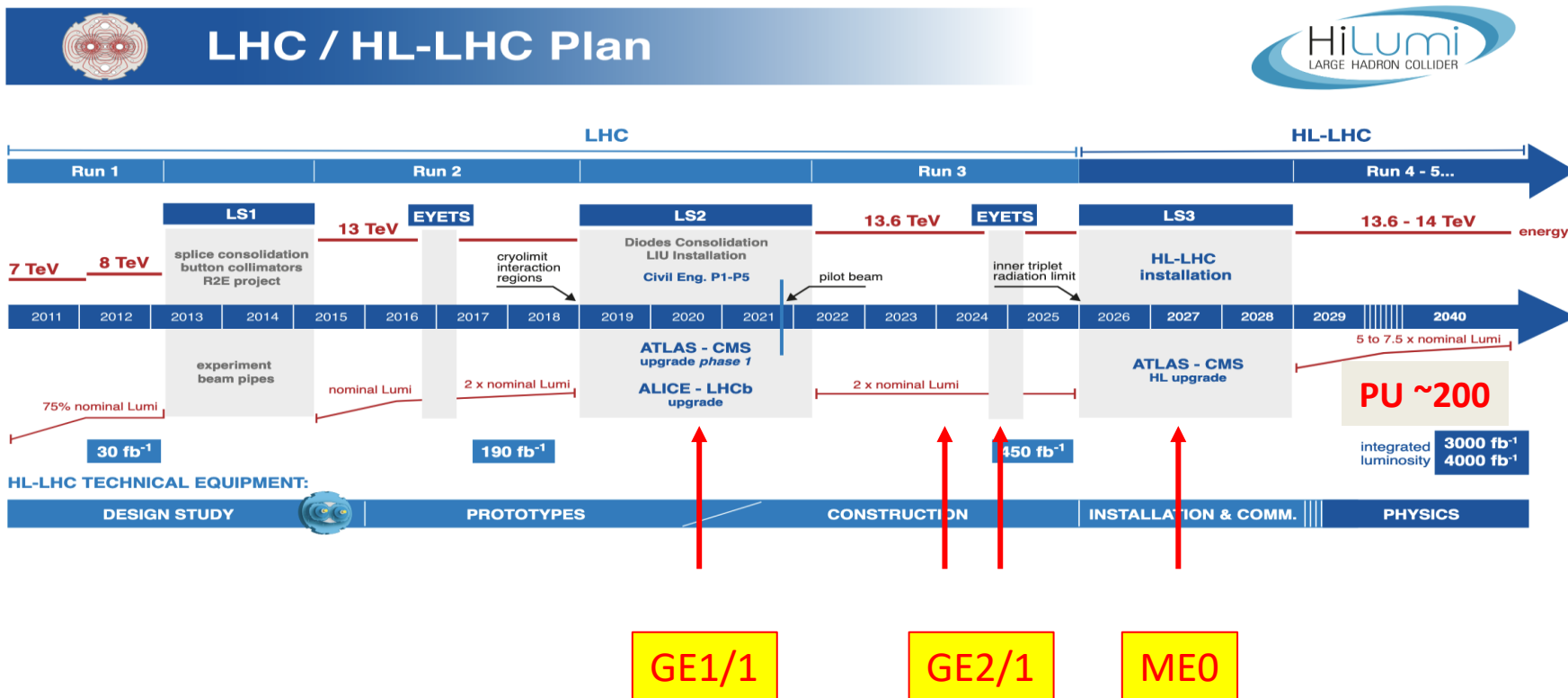



The long and winding road toward the GEMs for CMS

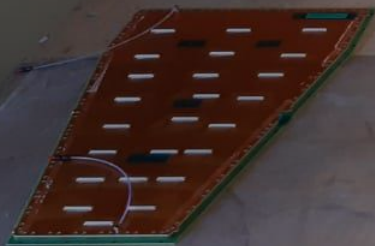

MEO

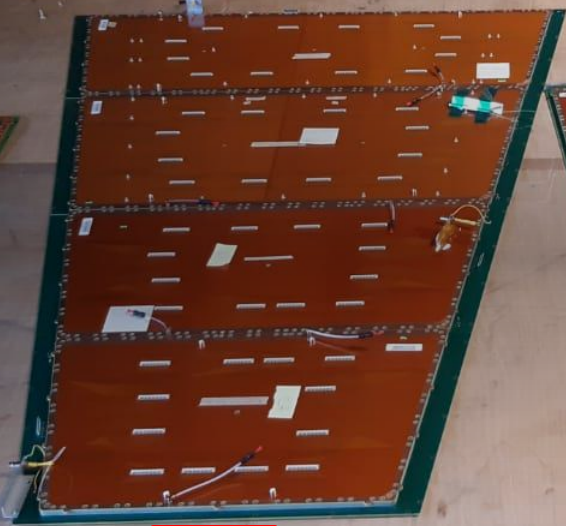

GE2/1

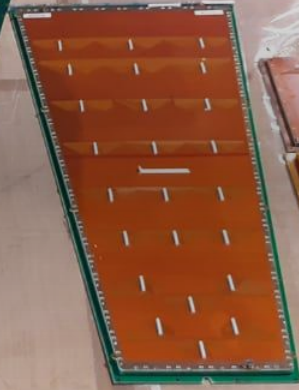

GE1/1

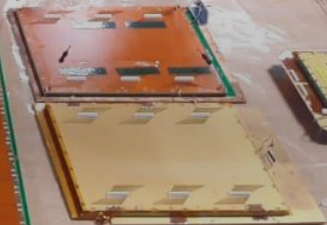

30x30 cm



10x10 cm

CMS DT MUON contact
Di Vincenzo 164055

The GE1/1 Project

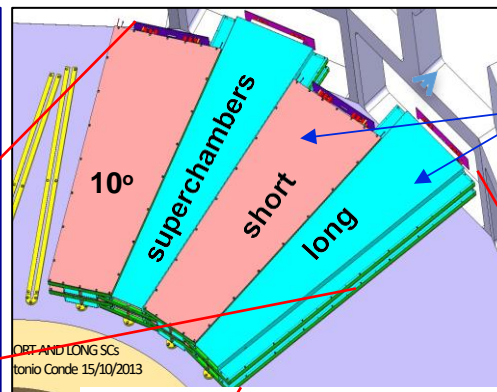
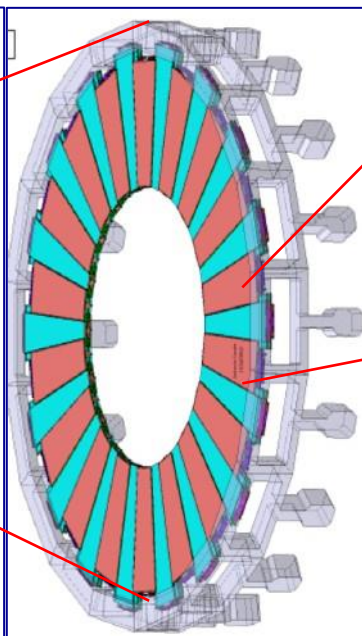
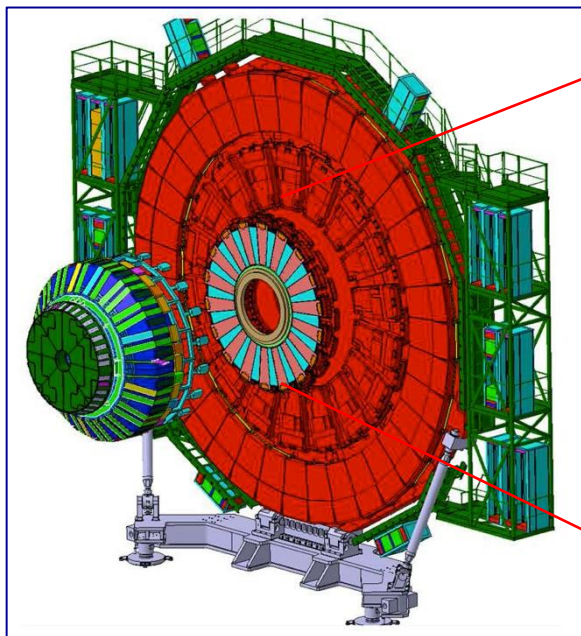

Two different shapes (long and short) to fit the CMS mechanical structure

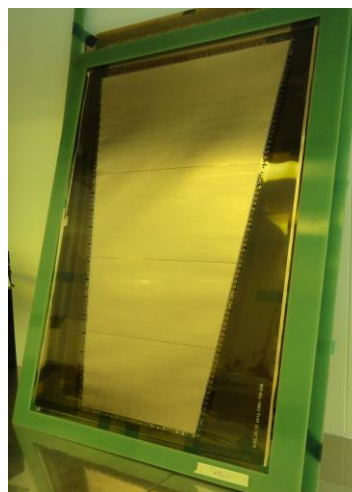
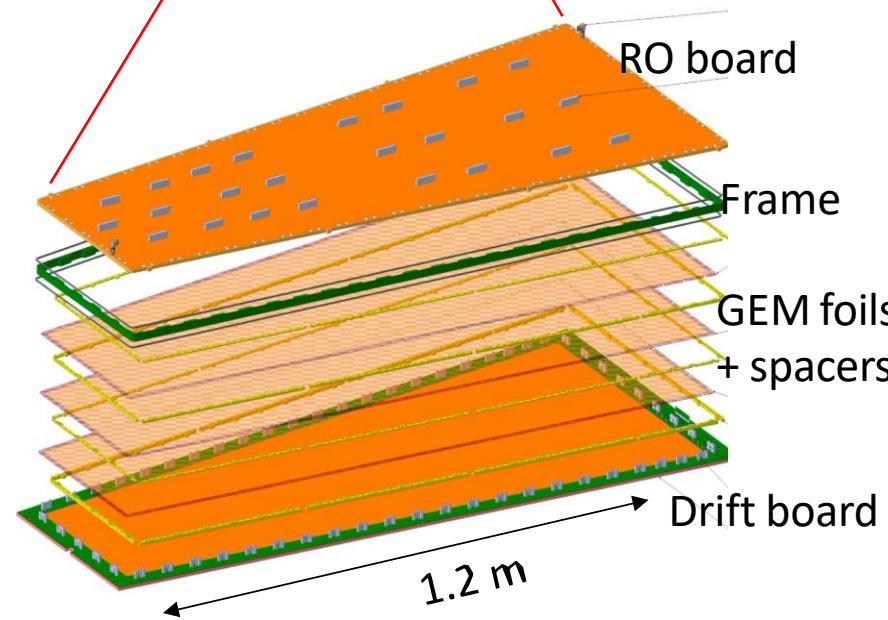

Triple-GEM detectors for the CMS upgrade:

- Trapezoidal chambers up to 1.2 m long
- 144 chambers associated in pairs (super-chambers) to form two disks, one per end-cap

Chamber story

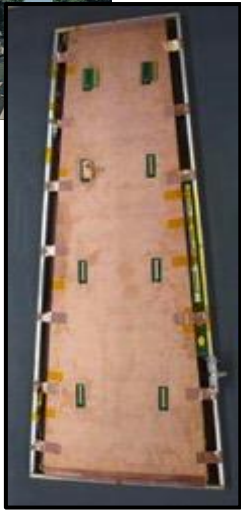

GE1/1-I

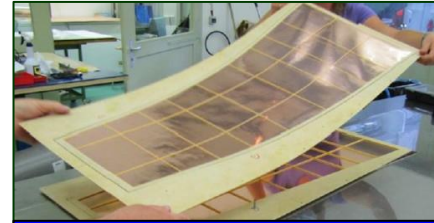

GEM foils on their frames



Thermo-stretching



Museum

2010

2011

2012

2013

2014

R&D phase

Toward production phase

GE1/1-I

- > first 1m-class GEM detector ever built
- > single-mask technology
- > $99 \times (22-45) \text{ cm}^2$
- > 1024 readout channels
- > gap config. 3/2/2/2
- > use of spacer grid and glue

Chamber story

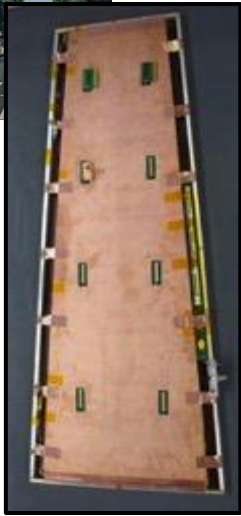

GE1/1-I



GE1/1-II



GE1/1-II

CMS M1 magnet: 3 T with a current around 4000 A
 GE1/1 region reaches 1.5 T

2010

2011

2012

2013

2014

R&D phase

Toward production phase

GE1/1-I

- > first 1m-class GEM detector ever built
- > single-mask technology
- > 99x(22-45) cm²
- > 1024 readout channels
- > gap config. 3/2/2/2
- > use of spacer grid and glue

GE1/1-II

- > Optimization of the electric field configuration
- > single-mask technology
- > 99x(22-45) cm²
- > 3072 readout channels
- > gap config. 3/1/2/1
- > use of spacer grid and glue

Chamber story

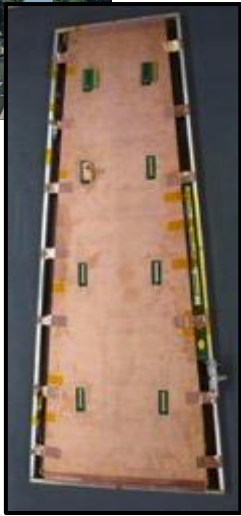

GE1/1-I

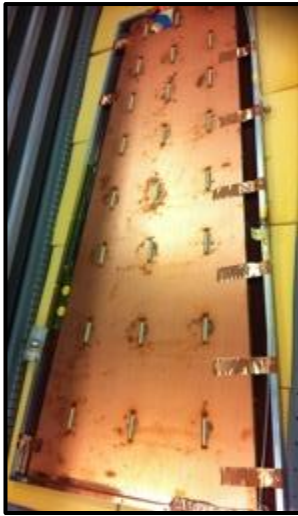

GE1/1-II



GE1/1-III

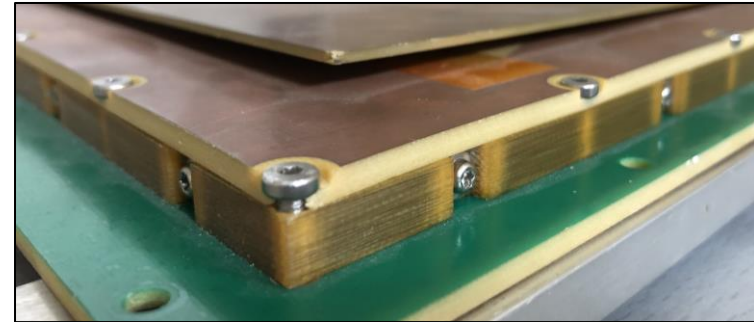

Pictures of the GE1/1 generation III external frame

2010

2011

2012

2013

2014

R&D phase

Toward production phase

GE1/1-I

- > first 1m-class GEM detector ever built
- > single-mask technology
- > 99x(22-45) cm²
- > 1024 readout channels
- > gap config. 3/2/2/2
- > use of spacer grid and glue

GE1/1-II

- > Optimization of the electric field configuration
- > single-mask technology
- > 99x(22-45) cm²
- > 3072 readout channels
- > gap config. 3/1/2/1
- > use of spacer grid and glue

GE1/1-III

- > first use of the self-stretching technique
- > single-mask technology
- > 99x(22-45) cm²
- > 3072 readout channels
- > gap config. 3/1/2/1
- > No spacers but glue on the external frame

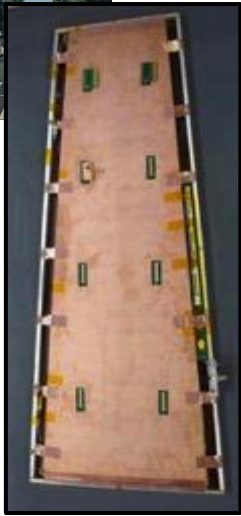

GE1/1-I



GE1/1-II



GE1/1-III



GE1/1-IV

2010

2011

2012

2013

2014

R&D phase

Toward production

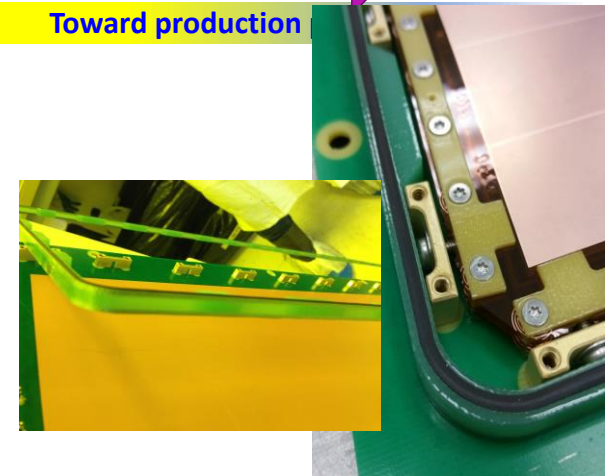
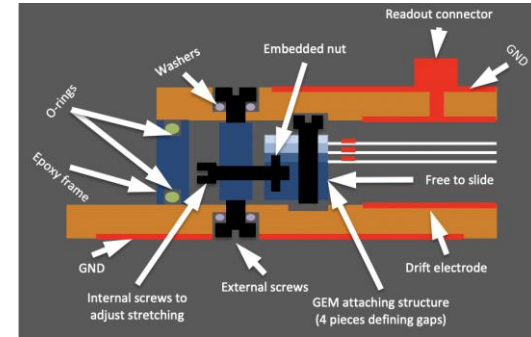

GE1/1-I

- > first 1m-class GEM detector ever built
- > single-mask technology
- > 99x(22-45) cm²
- > 1024 readout channels
- > gap config. 3/2/2/2
- > use of spacer grid and glue

Michele Bianco

GE1/1-II

- > Optimization of the electric field configuration
- > single-mask technology
- > 99x(22-45) cm²
- > 3072 readout channels
- > gap config. 3/1/2/1
- > use of spacer grid and glue

GE1/1-III

- > first use of the self-stretching technique
- > single-mask technology
- > No spacers but glue on the external frame
- > Stretching against the external frame

GE1/1-IV

- > Finalization of the stretching technique
- > Introduction of the pull-out
- > No glue/no spacers
- > **Assembly time reduced from 1 week to 2h!!!**

Chamber story

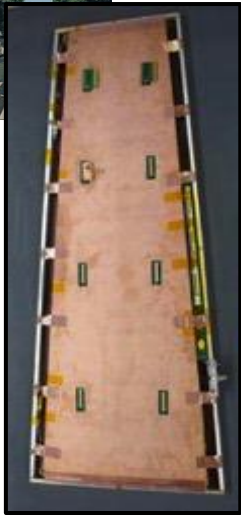

GE1/1-I



GE1/1-II



GE1/1-III



GE1/1-IV

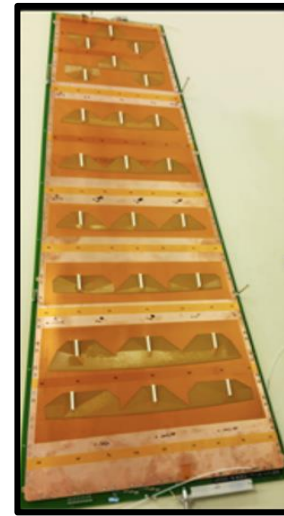

GE1/1-V

2010

2011

2012

2013

2014

R&D phase

Toward production phase

GE1/1-I

- > first 1m-class GEM detector ever built
- > single-mask technology
- > 99x(22-45) cm²
- > 1024 readout channels
- > gap config. 3/2/2/2
- > use of spacer grid and glue

Michele Bianco

GE1/1-II

- > Optimization of the electric field configuration
- > single-mask technology
- > 99x(22-45) cm²
- > 3072 readout channels
- > gap config. 3/1/2/1
- > use of spacer grid and glue

GE1/1-III

- > first use of the self-stretching technique
- > single-mask technology
- > No spacers but glue on the external frame
- > Stretching against the external frame

GE1/1-IV

- > Finalization of the stretching technique
- > Introduction of the pull-out
- > No glue/no spacers
- > **Assembly time reduced from 1 week to 2h!!!**

GE1/1-V

- > GE1/1 final layout
- > Modules used to design the QA/QC setup
- > **Modules distributed to the production sites for assembly and QA/QC training**

Chamber story



GE1/1-VI

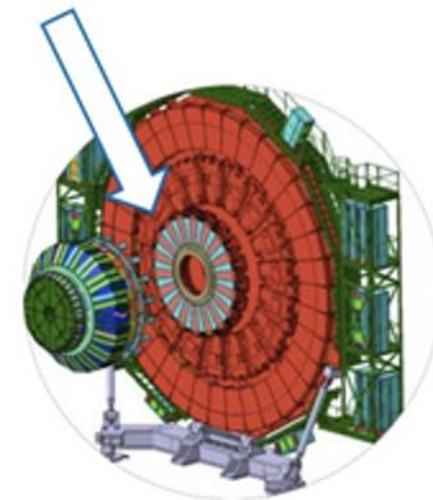
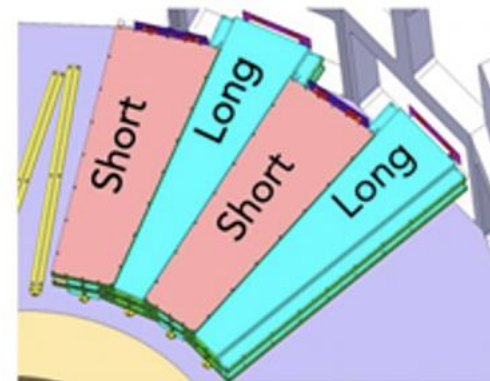

2015

2016

2017-2018-2019

TDR

Slice test installation

Production phase

GE1/1-VI

- > Latest detector design
- Optimization
- > Final dimensions for maximum acceptance (Long/Short) chamber

Chamber story



GE1/1-VI



GE1/1-VII

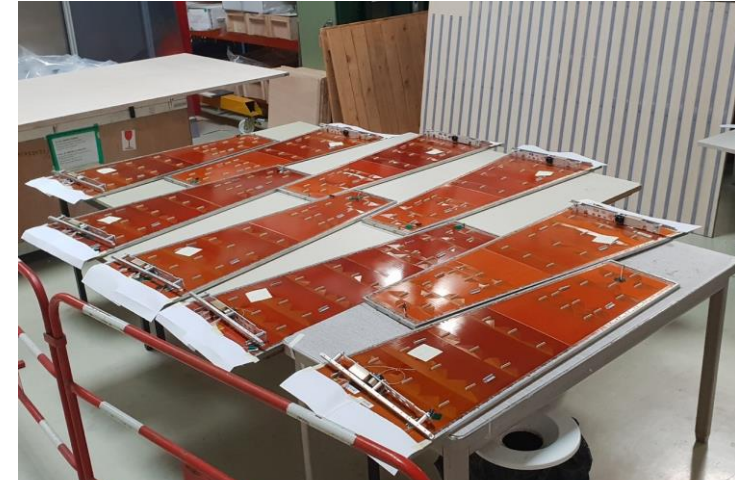

GE1/1 Slice Test Production

2015

2016

2017-2018-2019

TDR

Slice test installation

Production phase & installation

GE1/1-VI

- > Latest detector design
- Optimization
- > Final dimensions for maximum acceptance (Long/Short) chamber

GE1/1-VII

- > First Production in series of GE1/1 chambers (10 modules)
- > Process definition of the GE1/1 chamber assembly and certification

Chamber story



GE1/1-VI

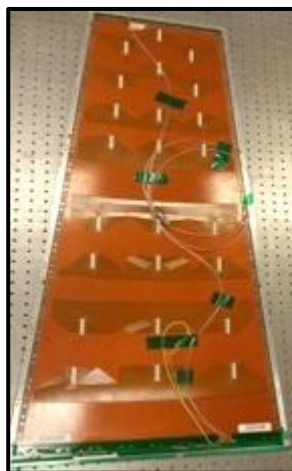

GE1/1-VII



GE1/1-X

2015

2016

2017-2018-2019

TDR

Slice test installation

Production phase & installation

GE1/1-VI

- > Latest detector design
- Optimization
- > Final dimensions for maximum acceptance (Long/Short) chamber

GE1/1-VII

- > First Production in series of GE1/1 chambers (10 modules)
- > Process definition of the GE1/1 chamber assembly and certification

GE1/1-X

- > External (w.r.t . CERN) production sites certification and chamber components shipment
- > GE1/1 chamber assembly and certification
- > Super chamber mechanics optimization
- > First test with final front-end electronics
- > GE1/1 super chamber assembly and certification with final front-end electronics

Demonstrator with 5 SuperChambers (SC) took place in **2017-18** with the goals to:

- Proving the system's operational conditions
- Developing the integration into the CMS online system
- Start acquiring installation and commissioning expertise

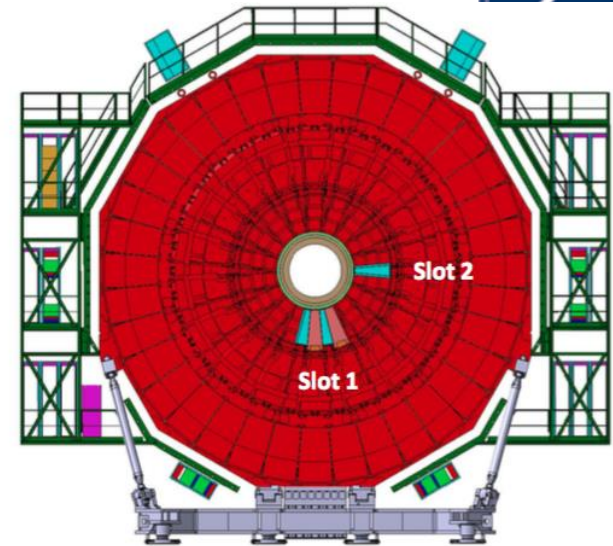

SLOT - 1 → 4 SCs:

- High Voltage supplied with a **single HV channel** per detector (8 HV channels in total)
- The HV is distributed to the detector's electrodes through a voltage divider
- Readout system based on **VFAT2 ASICs**

SLOT - 2 → 1 SC:

- HV supplied with a **multi-channel power supply** realized specifically for triple-GEM detectors (CAEN A1515TG)
- The HV module provides 7×2 voltage channels to power independently all detector's electrodes
- Readout system based on VFAT2 ASICs in 2017, **moved to VFAT3 ASICs in 2018**

The GE1/1 Slice Test

Slice Test exercise has been a fundamental opportunity to develop and test in situ the whole GE1/1 system (DAQ, DCS, DQM), and train a new generation of young expert

DCS developed, Finite State Machine (FSM) added, final integration reached at the end of 2017

GEM included in cDAQ

DQM Developed for Detector monitoring

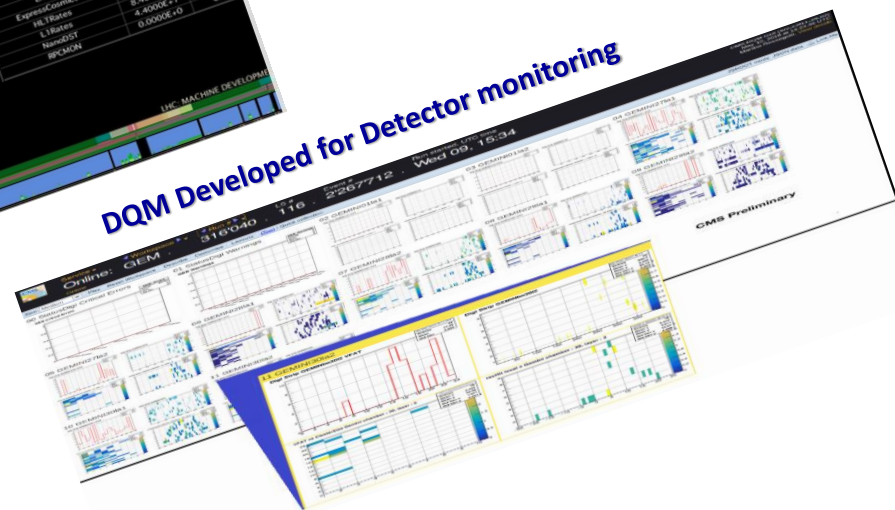

GE1/1 Slice Test: Success!

First results of reconstructing collision data with GEMs in muon reconstruction 2017/2018

CMS Experiment at the LHC, CERN
 Data recorded: 2018-Jul-08 19:55:40.193536 GMT
 Run / Event / LS: 319347 / 36141749 / 46

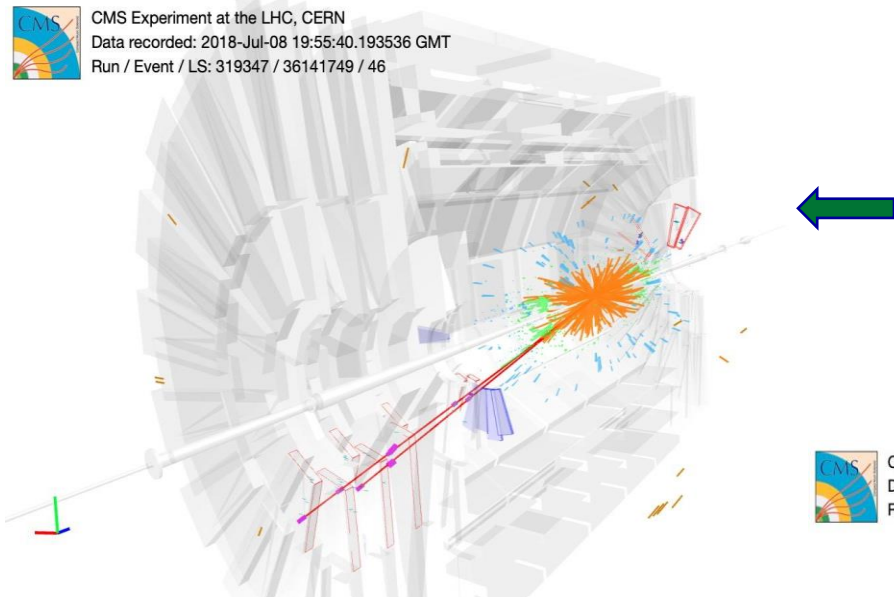

LHC run2 2018C p-p collision event display showing **two muons** (red lines), associated with hits on one of the five GE1/1 slice test super-chambers (blue trapezoidal boxes) at station 1 of the endcap muon system. The **antimuon** ($p_T = 30.11 \text{ GeV}/c^2, \eta = -1.956$) and **muon** ($p_T = 53.597 \text{ GeV}/c^2, \eta = -1.993$) has a combined invariant mass of **$3.011 \text{ GeV}/c^2$** (*J/Ψ meson particle*).

CMS Experiment at the LHC, CERN
 Data recorded: 2018-Jul-08 21:46:32.368896 GMT
 Run / Event / LS: 319347 / 438404601 / 331

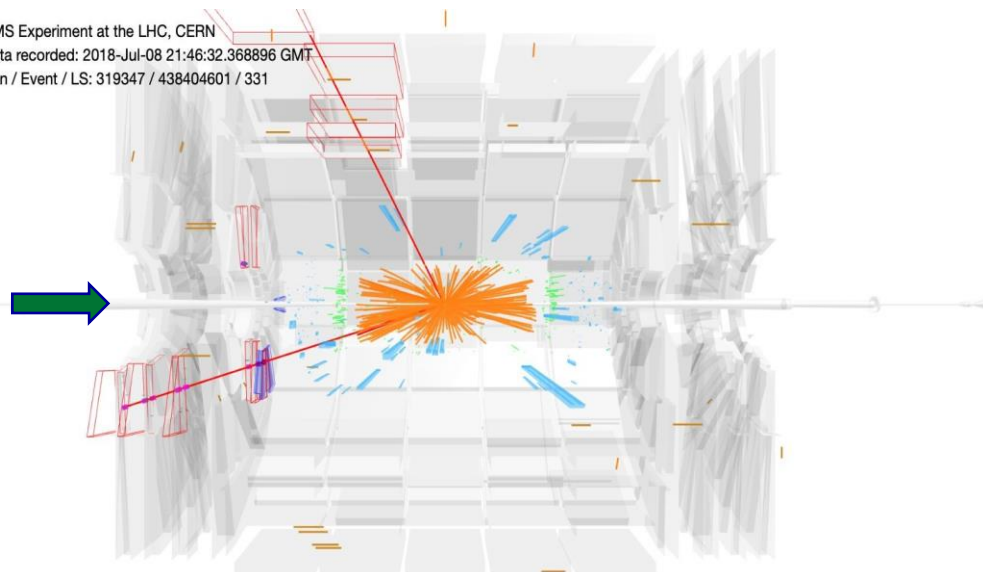

LHC run2 2018C p-p collision event display showing **two muons** (red lines), associated with hits on one of the five GE1/1 slice test super-chambers (blue trapezoidal boxes) at station 1 of the endcap muon system. The **antimuon** ($p_T = 34.01 \text{ GeV}/c^2, \eta = -0.540$) and **muon** ($p_T = 37.63 \text{ GeV}/c^2, \eta = -1.985$) has a combined invariant mass of **$91.141 \text{ GeV}/c^2$** (*Z⁰ boson particle*).

Mass Production & QA/QC



How to do?

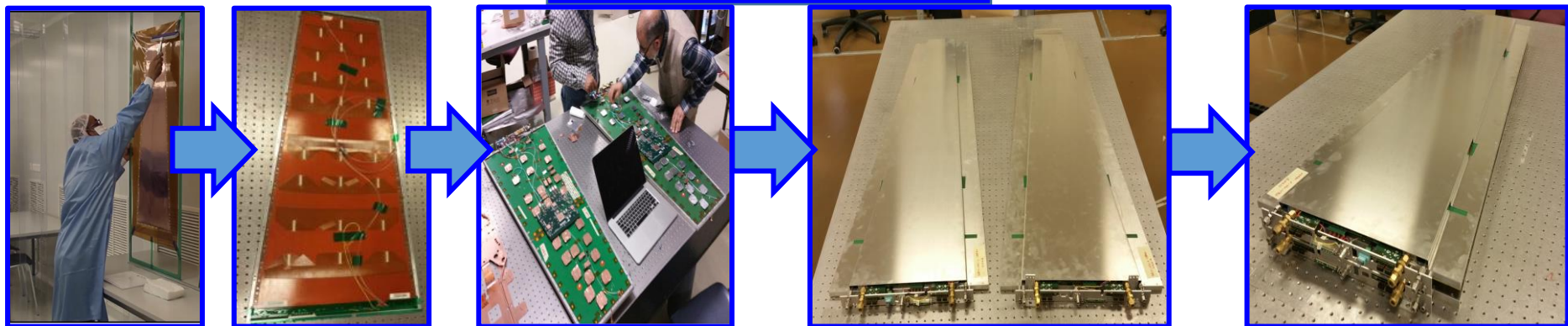

What do you need?

- A plan
- Infrastructures & Tools
- Validated process and certified manuals
- Time
- A Strong TEAM!!!



J.A. Merlin
GEM Production Manager

→ Distribution of the production in various sites:

- Share the effort with CMS - GEM institutes
- Generate a large community of GEM experts
- Equip production sites with infrastructure, tooling and knowledge for GE2/1 and ME0 productions

→ 2-years training program

- Using same procedure
- Using equivalent infrastructure
- All Quality Control deliverables validated by the production community

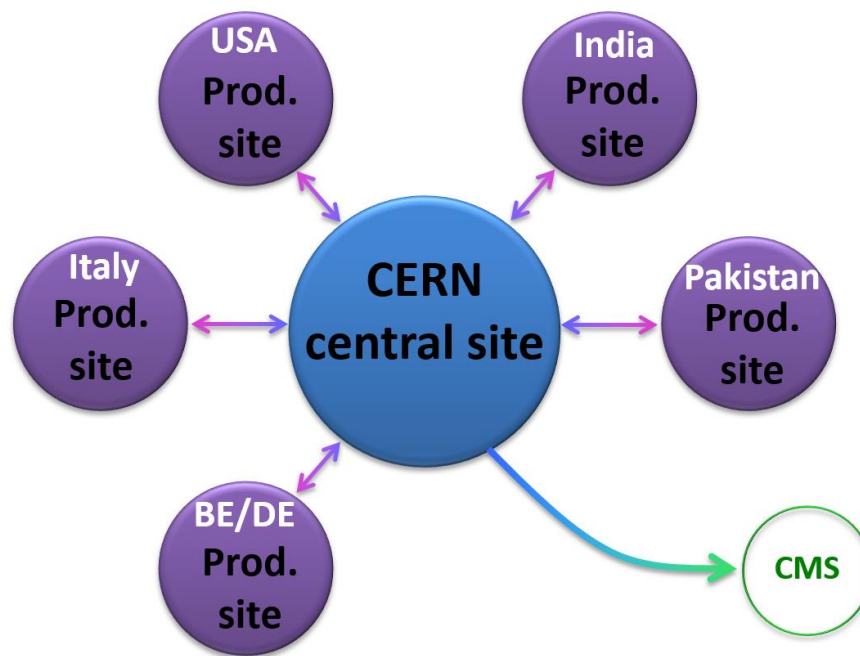

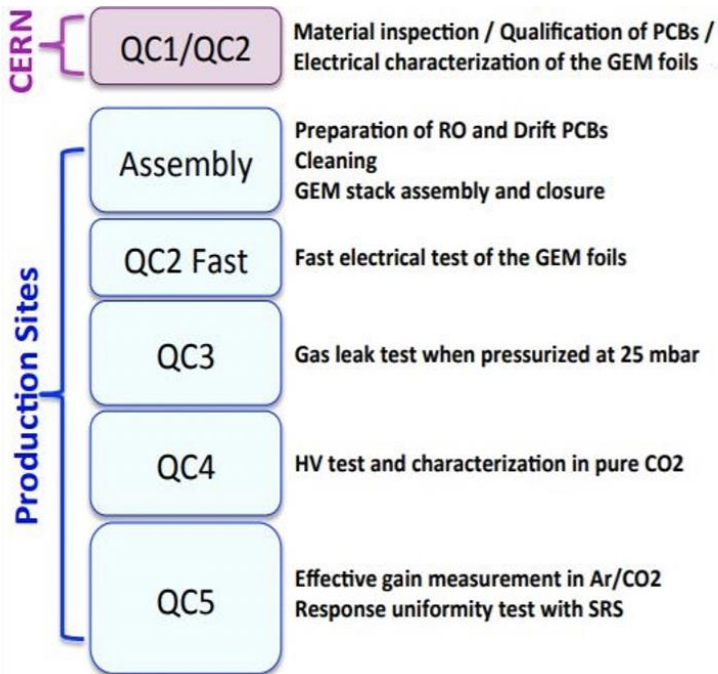

“Single-chamber” production summary:

- ✓ Successful and on-time production of both endcaps from Sept. 2017 to Dec. 2018
- ✓ In total 161/144 GE1/1 detectors:
 - 2 used for R&D activities (aging and discharge studies)
 - 3 required in-depth investigation (discarded)
 - 156 fully validated up to QC5 (yield > 97%)

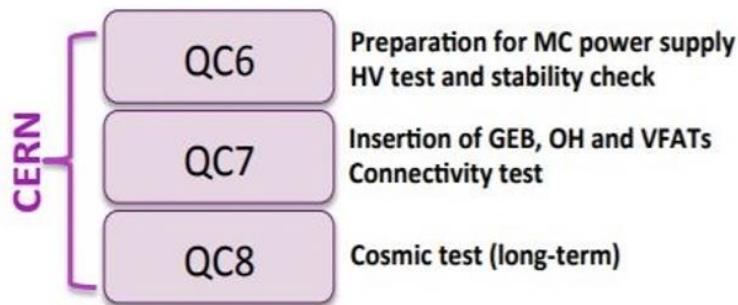

“Super-chamber” production summary:

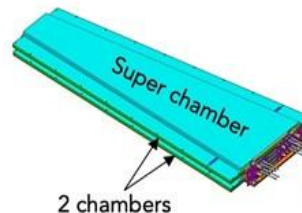

- ✓ 100% completed (76/72 needed in CMS)

New production facility in B904:

- Clean room class 1000 and better - 102 m² + 18 m² (SAS) -
 - Zone with improved class quality for detector assembly
 - Can accommodate two production lines in parallel
- Test laboratory in 904/R-D09 (previously RPC) - 284 m² + storage space -
 - Can accommodate two testing lines in parallel
 - Can handle the last steps of the SC assembly and commissioning



The Clean Room in 904 building



X-Ray Boxes & RP Area



The GEM QA/QC Lab (The cosmic stand)



Manual for production site inspection and validation

GE1/1 Production Site Checkout Document

M. Bianco¹, B. Dorney², J. Merlin³ on behalf of the *CMS Muon Group*

Manual for chamber assembly (in dedicated papers)

Technical Assembly Manual for GE1/1 Chambers

M. Abbas^{2, 3}, M. Bianco^{*2}, M. Gola^{†1}, J. A. Merlin^{‡2}, R. De Oliveira², and A. Shah¹

GE1/1 Quality Control : instructions

Michele Bianco^{*}, Brian Dorney[†], Jeremie A. Merlin[‡]

Manual for chamber qualification and certification

Assembly video tutorial illustrates the preparation and the assembly (1,5 h video)

Assembly training at CERN, 10 sessions, components of all production sites

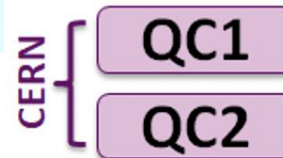

→ *Internal / external frames*

- Optical inspection to identify possible cracks,
- Measurements of the width and depth of the grooves that will accommodate the Viton O-ring

→ *Viton O-ring*

- Measurements of the external diameter in order to ensure a correct coupling between the O-ring and the external frame and ensure a correct gas-tightness

→ *Drift/RO PCBs*

- Optical inspection for planarity check and possible macroscopic scratches or defects on the readout strips or readout connectors
- Connectivity test in order to inspect the readout board for possible shorts between strips or open strip-readout connections

→ *GEM Foils (Fast & Long Test)*

- Fast: Inspection for major defects, test with manual Insulator/Continuity tester (10 minutes, counting for eventual sparks)
- Long: Ultimate certification of the GEM-foils before the installation in the GE1/1 detectors, conducted using HV module with 50 pA of current resolution, GEM foils exercised in different steps between 100 and 600V in pure N₂.

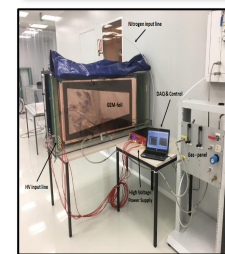
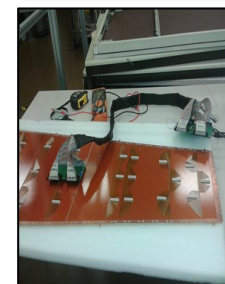
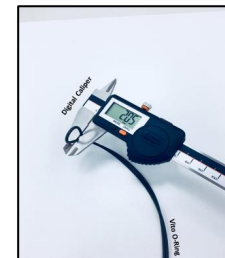
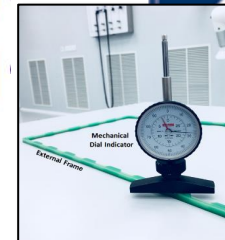

Assembly of GE1/1 chamber

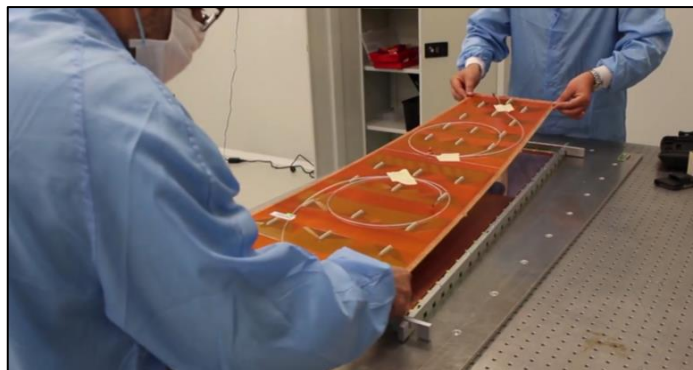
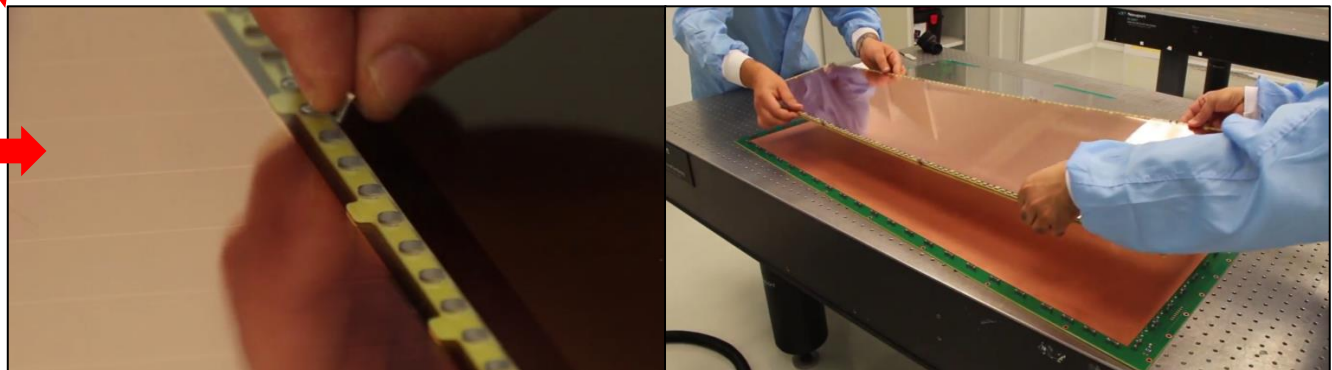
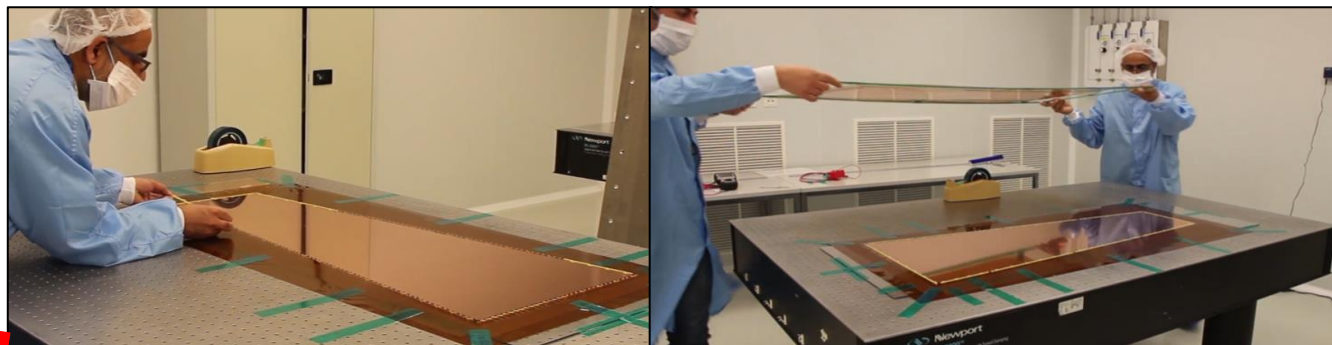
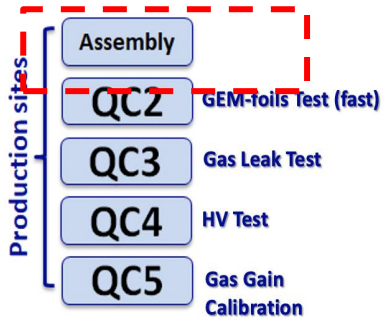

Foils stretched by hand, attached to the working table, the stack is assembled and fixed by means of FR4 frames than moved inside the Drift PCB Board



Foils stretched against the "pull out" and chamber closed placing the Readout Board

Full Assembly Process in Backup ([Annex B](#))

CERN, July 8th, 2022 p. 43

Motivation:

To check gas-tightness and avoid gas leaks

Acceptance criteria:

The detector under test is validated if the pressure drop in the detector + gas system does not exceed:

$$\Delta P \leq 7 \text{ mbar/hr}$$

at initial over-pressure of 25 mbar, which corresponds to a gas leak time constant:

$$\tau \geq 3.04 \text{ hr}$$

Motivation:

To check the on-detector circuitry & Intrinsic Noise

Acceptance criteria

$$\frac{|R_{\text{measured}} - R_{\text{expected}}|}{R_{\text{expected}}} \times 100\% \leq 3\%$$

$$R_{\text{noise}} \leq 0.02 \frac{\text{Hz}}{\text{cm}^2} \text{ (at 4.9 kV)}$$

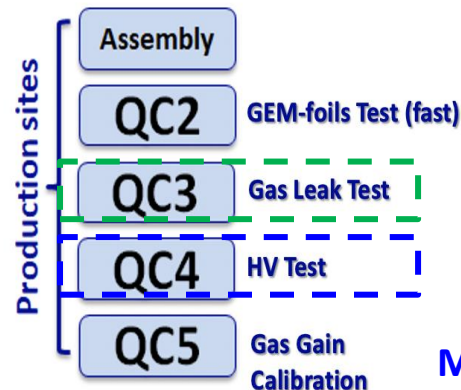
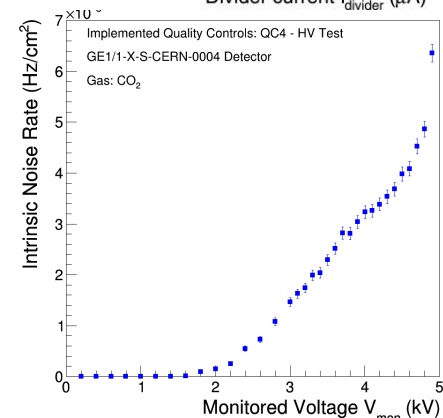
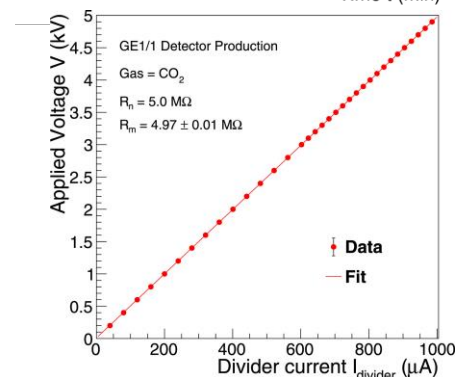
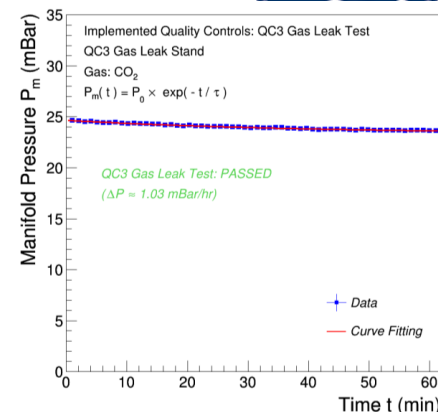

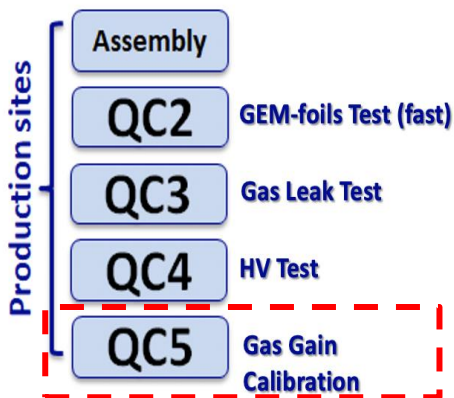

- Measurement taken in Ar/CO₂ 70/30
- Both tests performed inside a copper box using an X-ray generator (~ 22 keV X – rays)



STEP 1: Effective Gas Gain Measurement

Effective gas gain versus HV in one readout sector, the

Effective gas gain is defined as: $G_{\text{eff}} = \frac{I_{\text{RO}}}{(n_p \times q_e \times R_s)}$

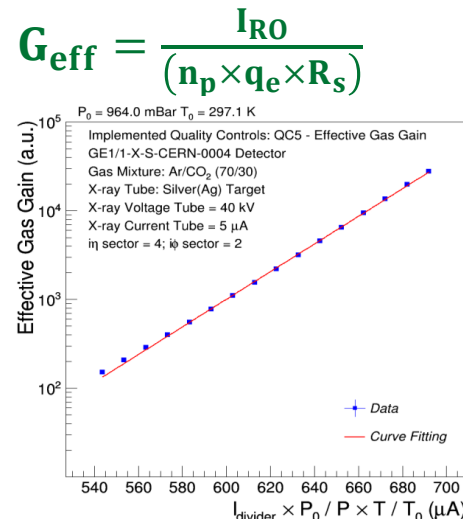
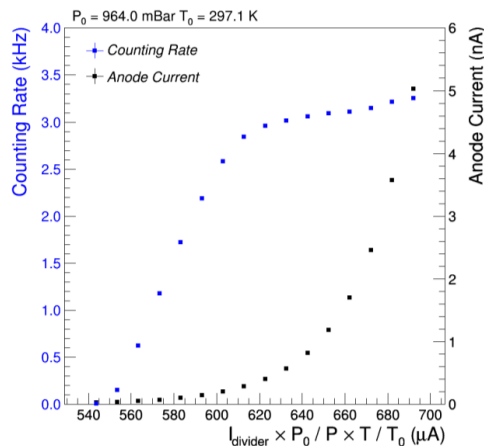

STEP 2: Response Uniformity Measurement gas gain variations map

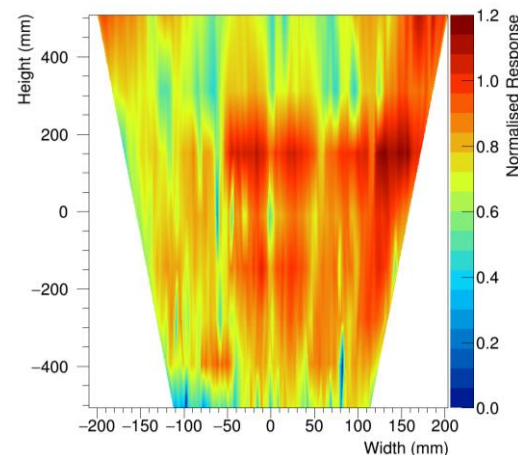
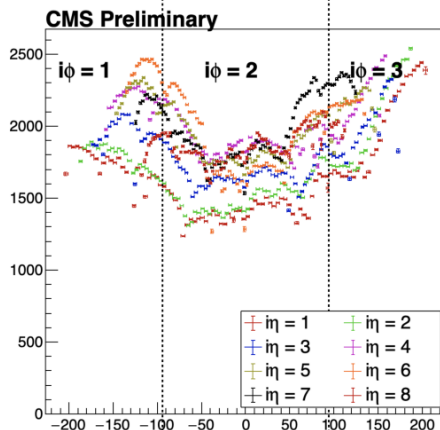

The Team!!!

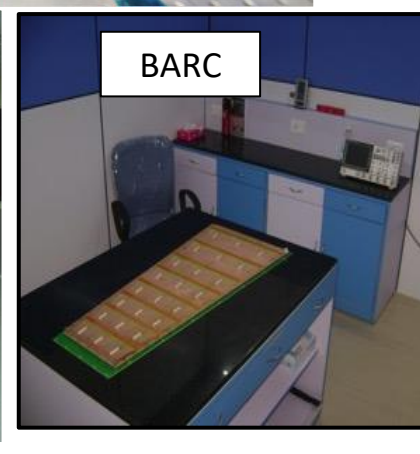
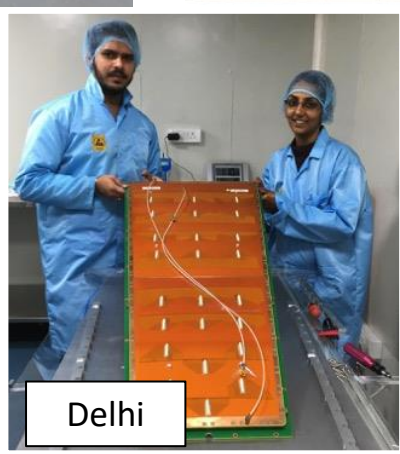
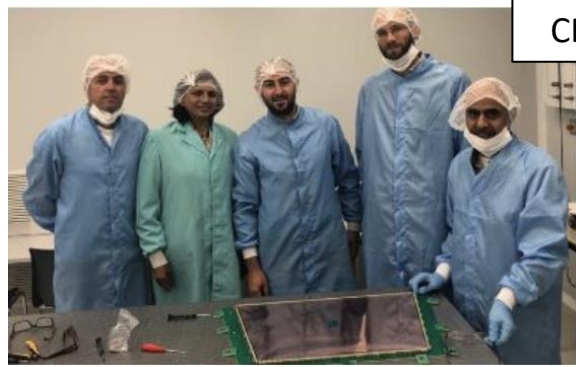
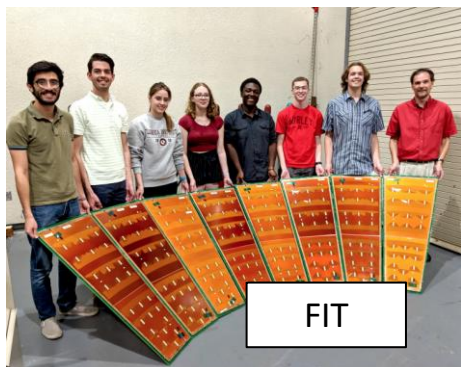
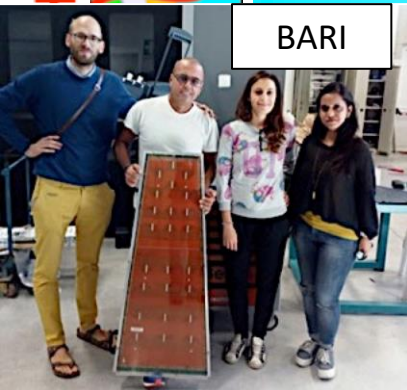

The Production Manager!!!

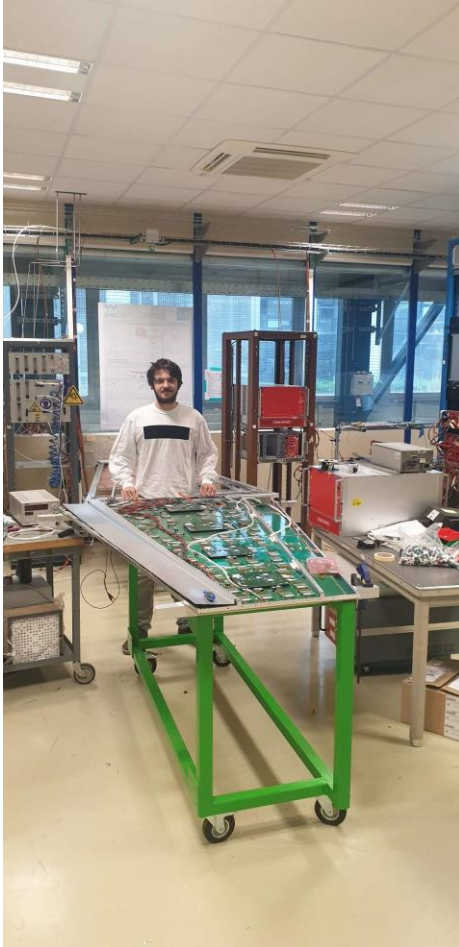

The GE1/1 electronics

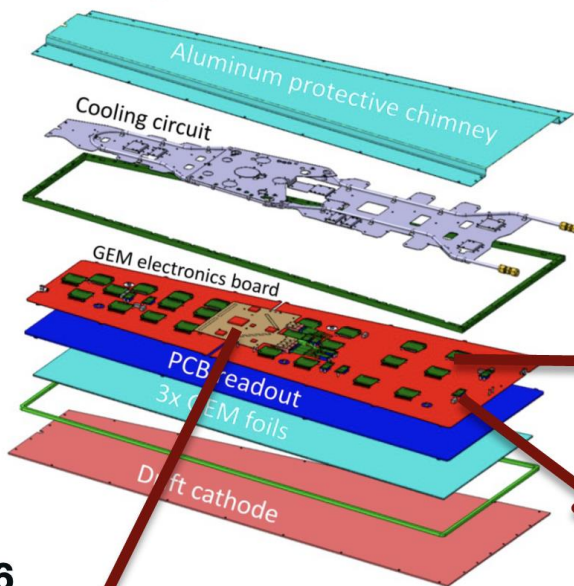

GE1/1 system:

- 72 Super-Chambers (SC)
- 3456 VFAT3 chips
- 432 GBT + VTRx optical link (DAQ path)

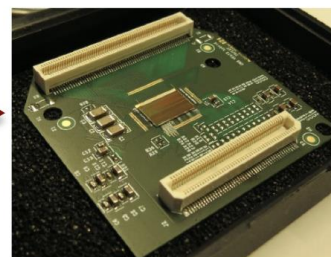

FE chip: VFAT3

- 24 VFAT3 / chamber
- 128 channels / chip
- Binary readout
- Tracking + Trigger data

- [1] Virtex-6
- [2] GBTx

GE1/1 Electronics

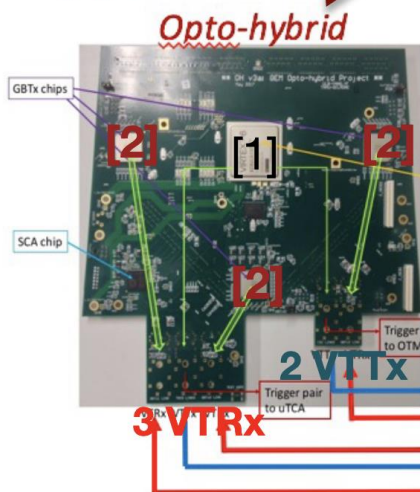

— Trigger data (3.2 Gbps – 10b/8b)
 — GBT links: Tracking data (4.8 Gbps)

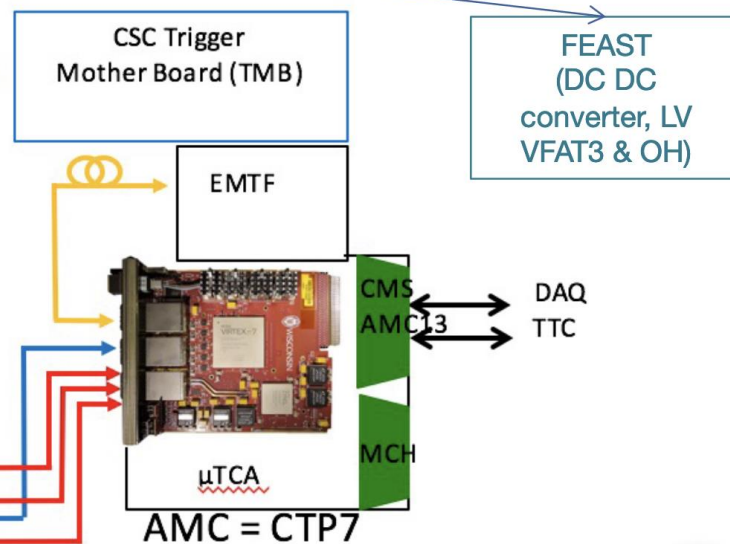

- Mounting of the GEB and on-chamber services (LV, gas pipes, grounding)
- Mounting of the OH and optical fibers
- Mechanical fixation of all components
- Verification of the voltages at the OH and FEAST levels
- **First round of electronic connectivity test & noise measurement**
- Cooling installation
- **Second round of electronic connectivity test & noise measurement**

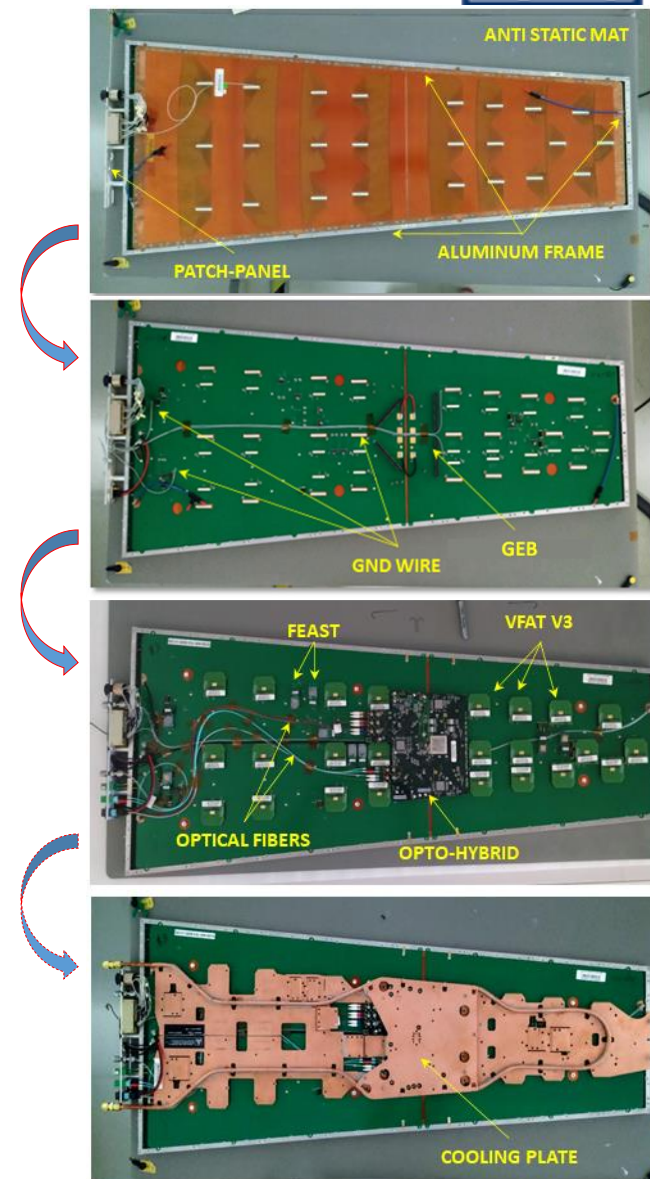

Chamber selection for SC assembly

- Define the detector pool (not already paired, QCs passed and validated)
- Compile the QC data to select the chambers with the most similar characteristics

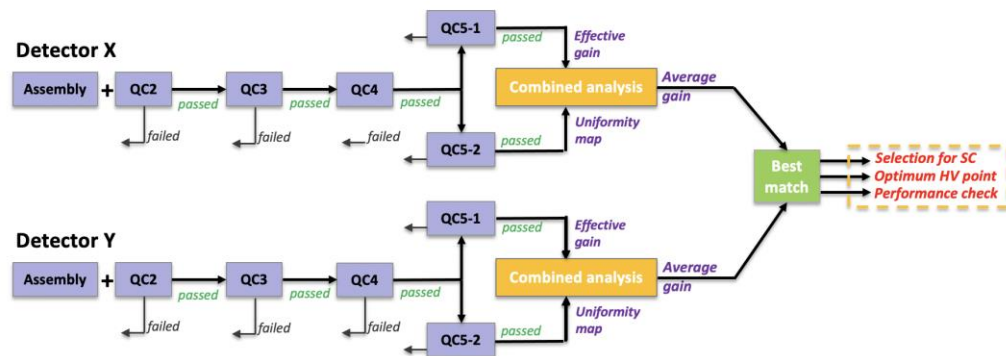

Super-Chamber (SC) validation

- Test the SC at nominal HV (check for possible discharges or instabilities)
- Measure the SC performance using cosmic rays (2 weeks-long test)

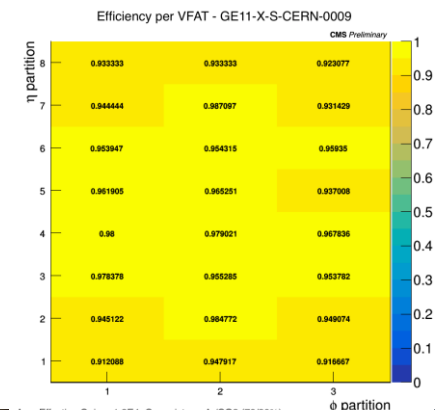
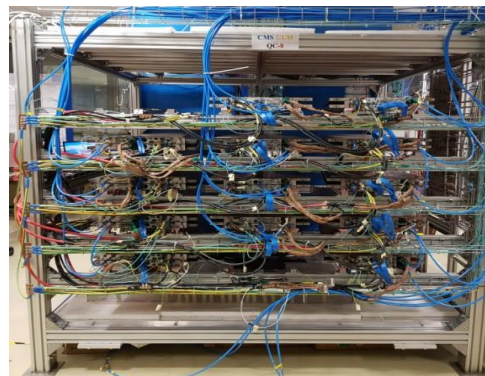

Final tests

- Check for possible leaks on the cooling system
- Measure the relative position of the two layers in the SC (photogrammetry)
- Last verification of the patch panel connections

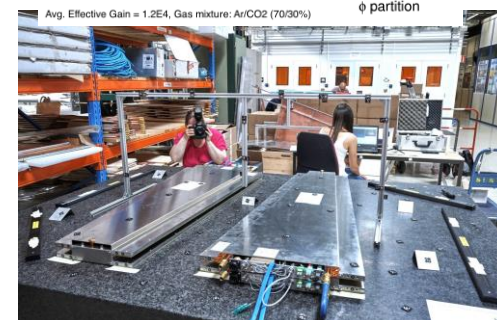

Ready! Move to P5

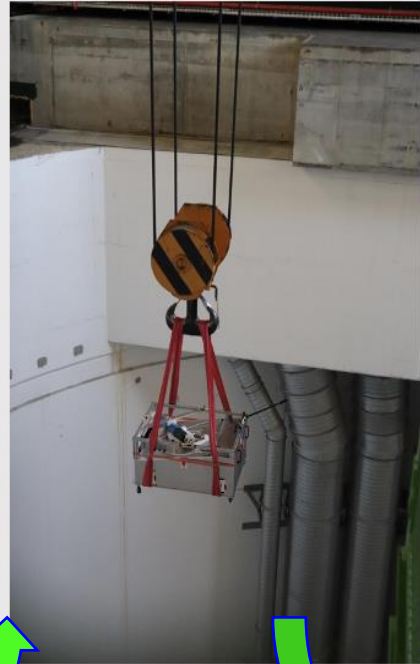
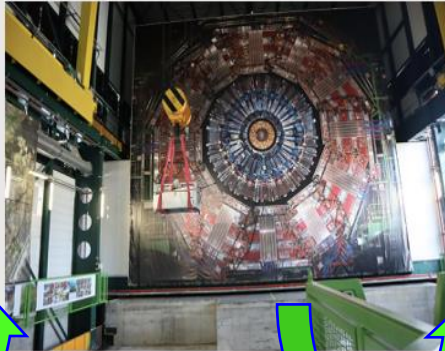

GE-1/1 SCs installation in the negative end-cap

- ✓ Installation of all 36 super-chambers for the first end-cap completed in Oct. 2019
- Multiple installation windows from July 2019 to October 2019

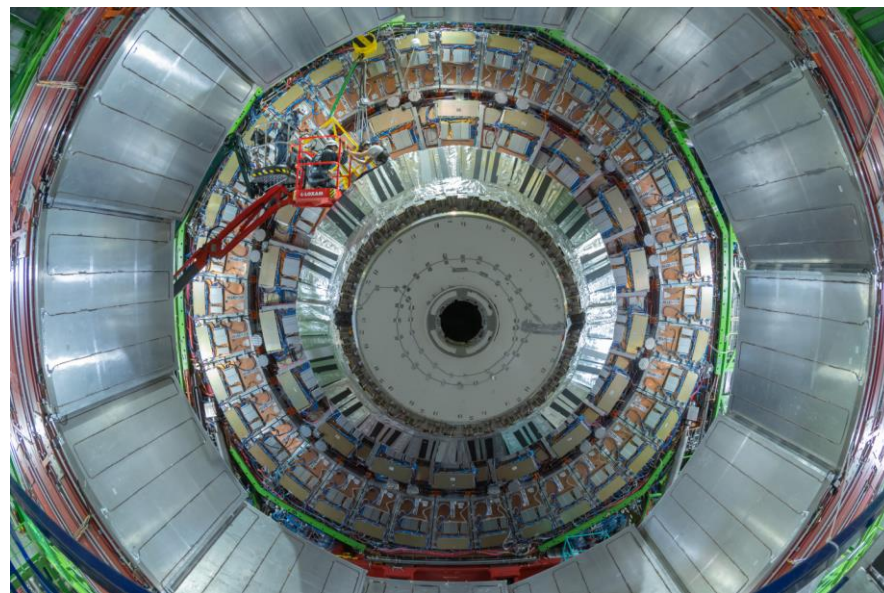
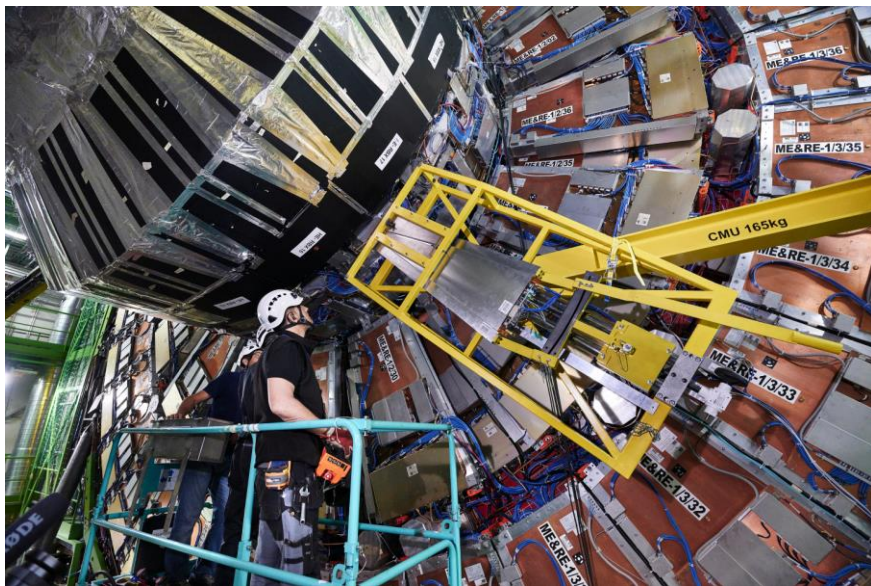

GE-1/1 SCs installation in the positive end-cap

- ✓ Installation of all 36 super-chambers for the second end-cap completed in Sept. 2020
- Installation and commissioning phase delayed to the COVID-19 lockdown

The early commissioning

- Ritual HV/LV/Gas/RO Fiber ... (in two words Detectors Services) maps checks
- HV training for GEM foils before applying regular HV settings

You're ready to go for data taking but ..

- High levels of **noise** in the detector were measured already during early 2020 commissioning and confirmed at the end of the installation
 - Extensive campaign to investigate noise level in spring '21
 - Due to conflicting schedule of operations and experts, the testing campaign was conducted at night after the end of the daily operations
- Effect was found to be linked to the GEM LV system
 - **LV filters** were developed to improve substantially the noise level in most of the problematic chambers
 - Installation of the filters conducted in May 2021

LV-/LV+ Filters
(PCB with SMD components)

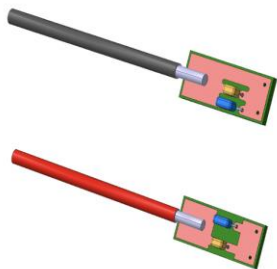

PCB layout (34 um of coppers)

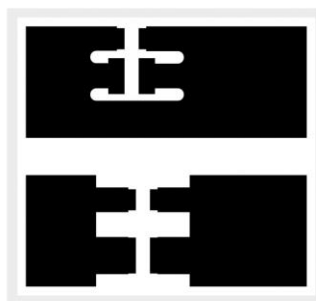

Filter application and connection to ground

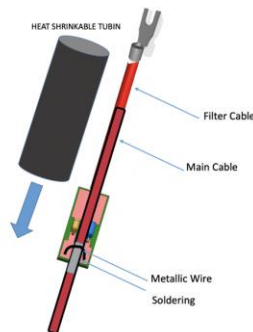

Adapter for P5

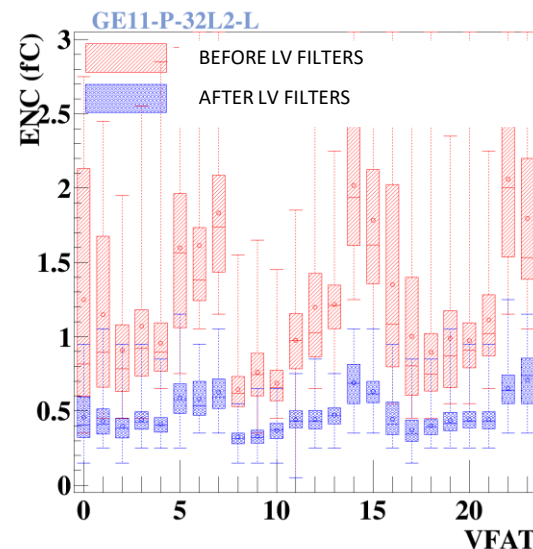

As ALICE number of trips at the first Magnet ramp up, summary of dedicated studies at the following link:

https://agenda.infn.it/event/22092/contributions/167812/attachments/91050/123179/Scalzafé_PisaPoster_Draft_5.pdf

CMS Preliminary Cosmic Ray Muon Data 2022

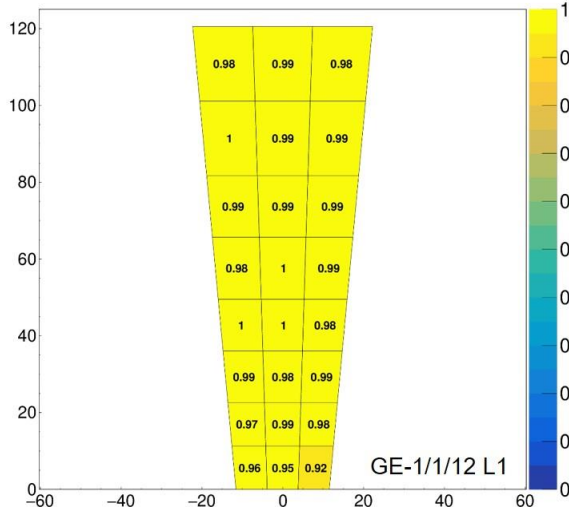

CMS Preliminary Cosmic Ray Muon Data 2022

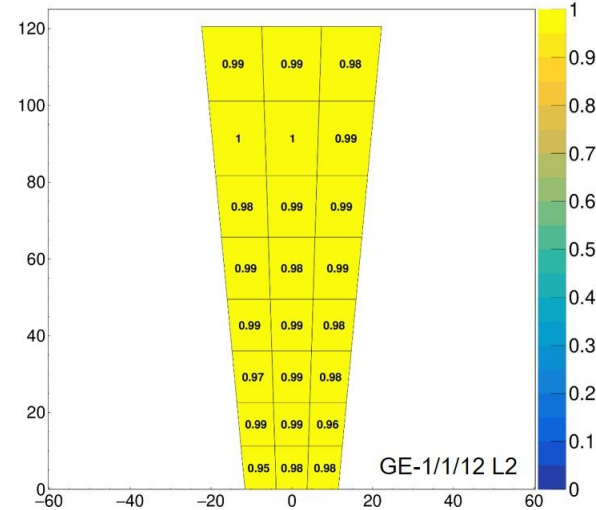

Efficiency (per VFAT) on Layer 1 (left) and Layer 2 (right) of GE1/1 superchamber 12 in the minus endcap for cosmic ray muons taken in 2022.

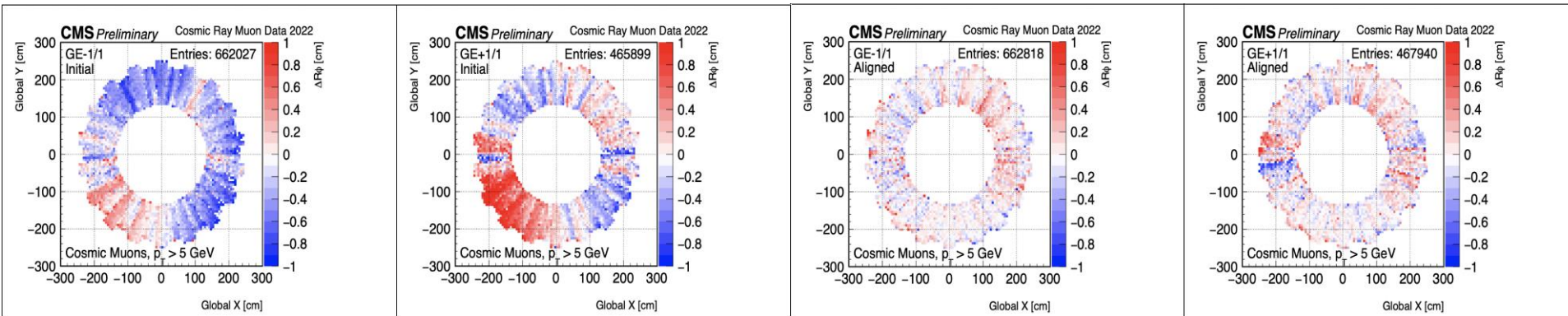

Residual map on GE1/1 superchambers (before its alignment) relative to the ME1/1 geometry

Residual map on GE1/1 superchambers (after its alignment) relative to the ME1/1 geometry

Commissioning with Cosmics



2022 CRAFT MUON IN GEM (+CSC +RPC)

CMS Experiment at LHC, CERN
Data recorded: Sun Apr 10 07:36:04 2022 CEST
Run/Event: 350166 / 578929503
Lumi section: 367

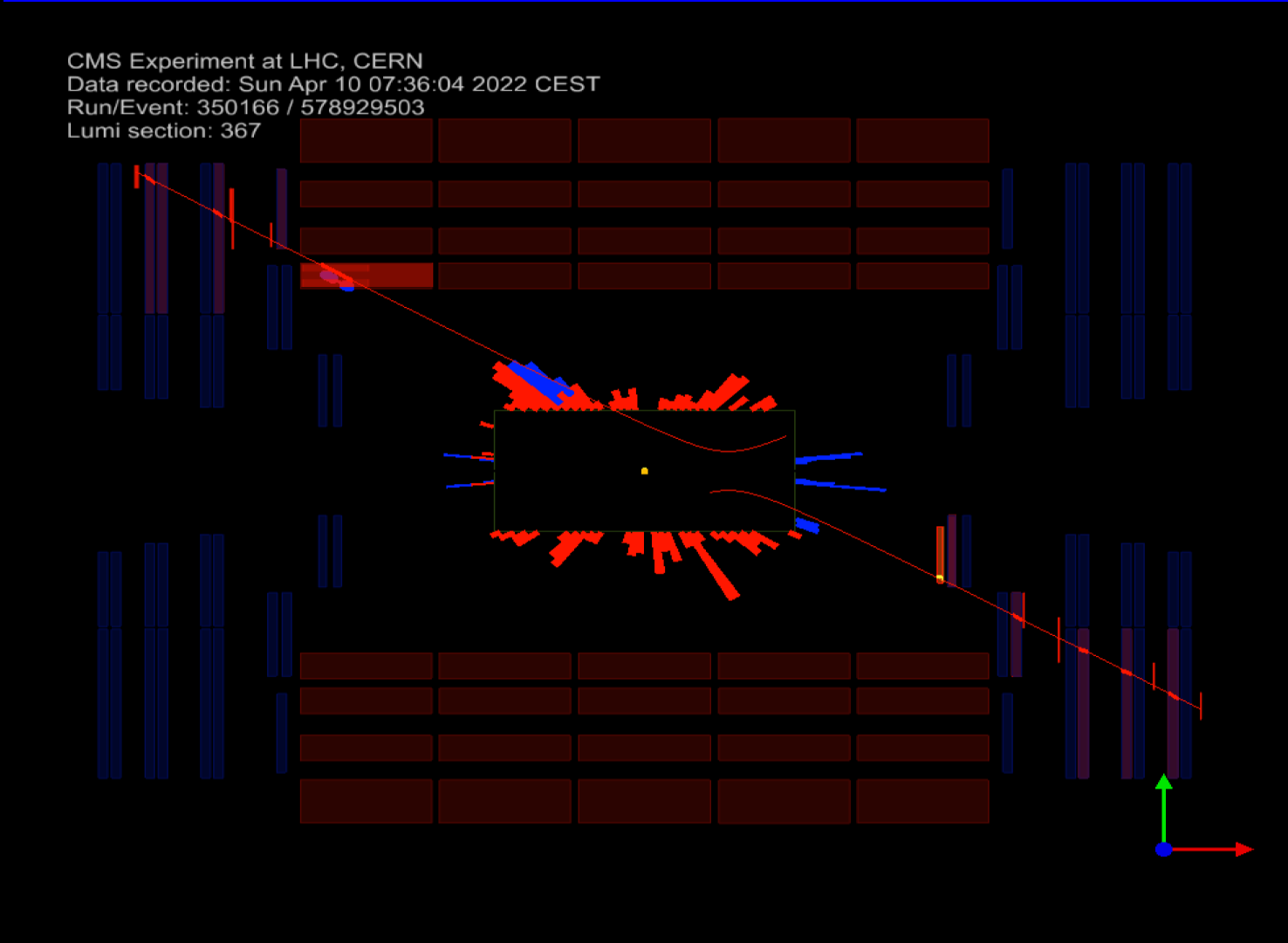

2021 TEST COLLISION DI-MUON IN GEM (+CSC +RPC)



CMS Experiment at the LHC, CERN
 Data recorded: 2021-Nov-01 00:20:45.992512 GMT
 Run / Event / LS: 346509 / 28321286 / 30

- Test pp collisions at 900 GeV - Nov 2021
- A candidate $J/\psi \rightarrow \mu\mu$ event in CSCs
 - Invariant mass of the two global muons = 3.1 GeV
 - +RPC rechits on one muon;
 - +GEM segment on the other

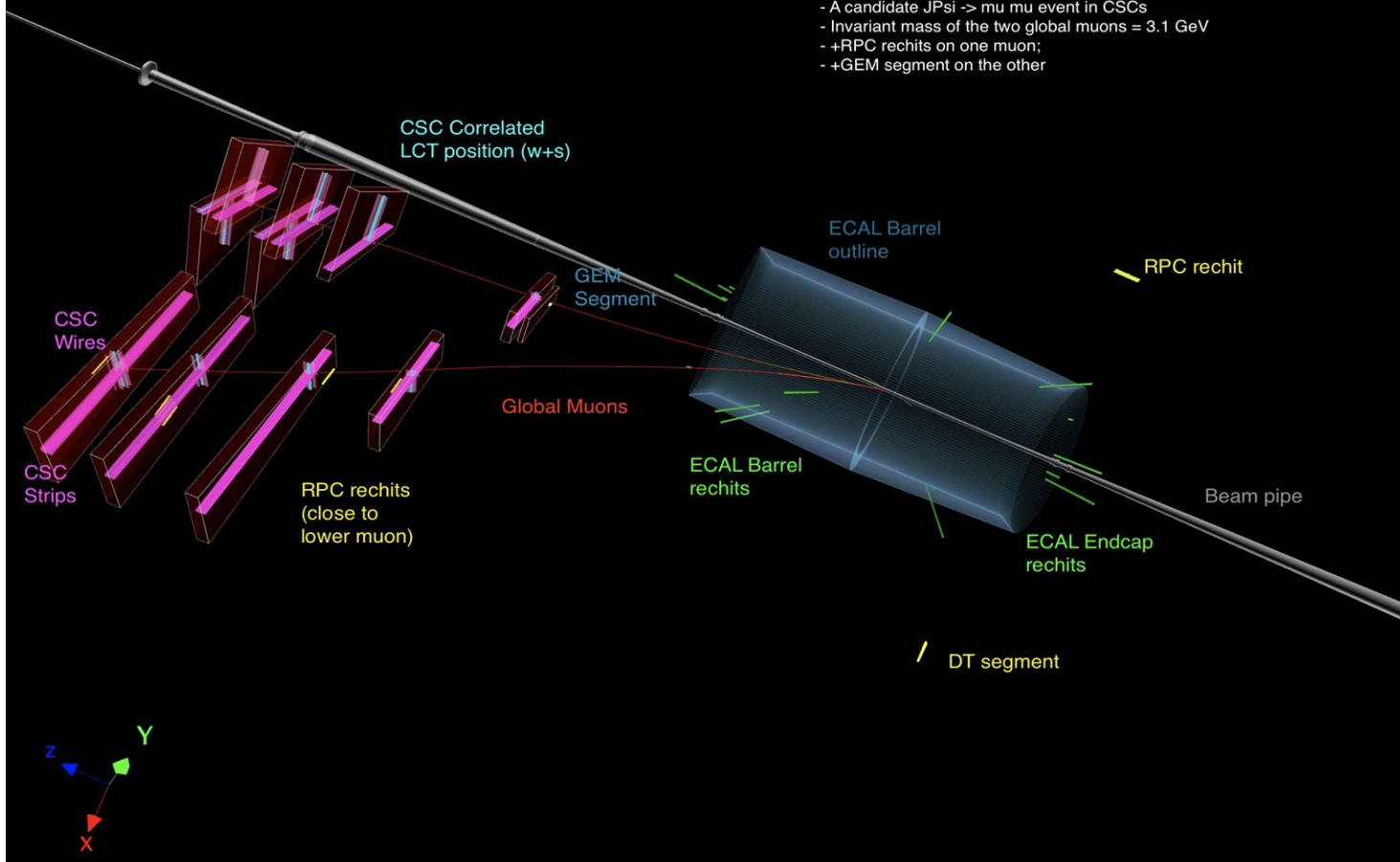

The GE2/1 Project

- Triple-GEM technology (same as GE1/1)
- 36 GE2/1 chambers per end-cap, organized in two layers of 18 chambers
- Each chamber consists of 4 GE2/1 modules
 - 288 modules in total
- Two different types of chambers to avoid the overlapping of dead areas
 - 8 different module designs called M1 to M8
- **Installation planned in YETS 2023/24 & 24/25**

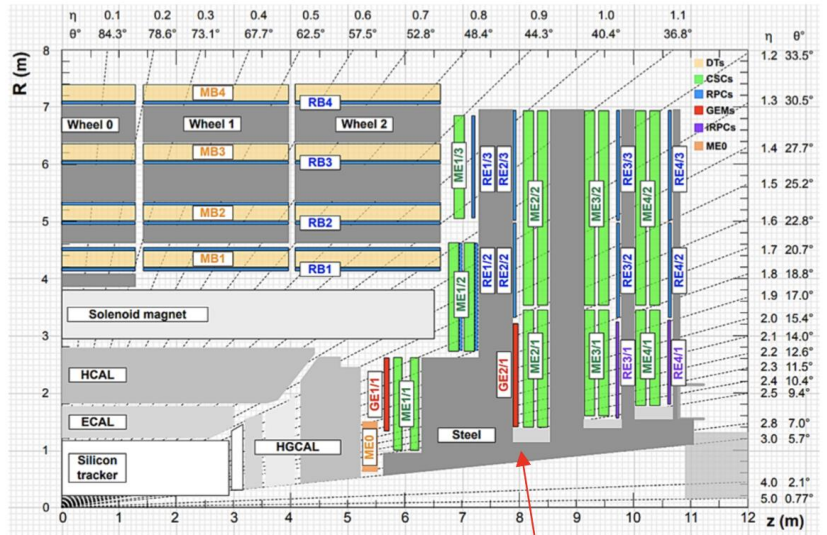
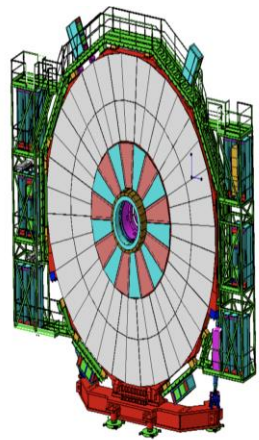
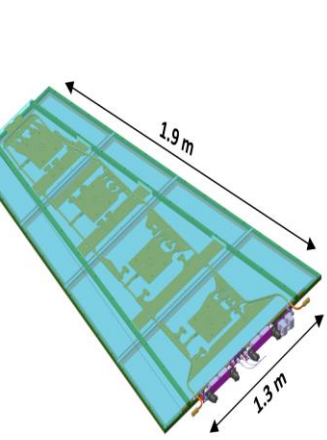
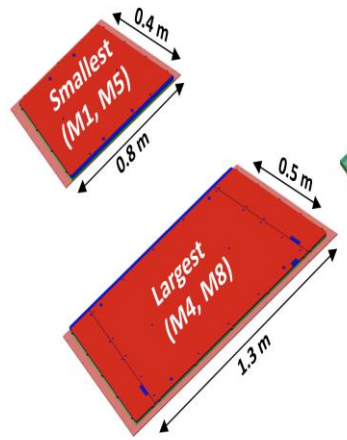
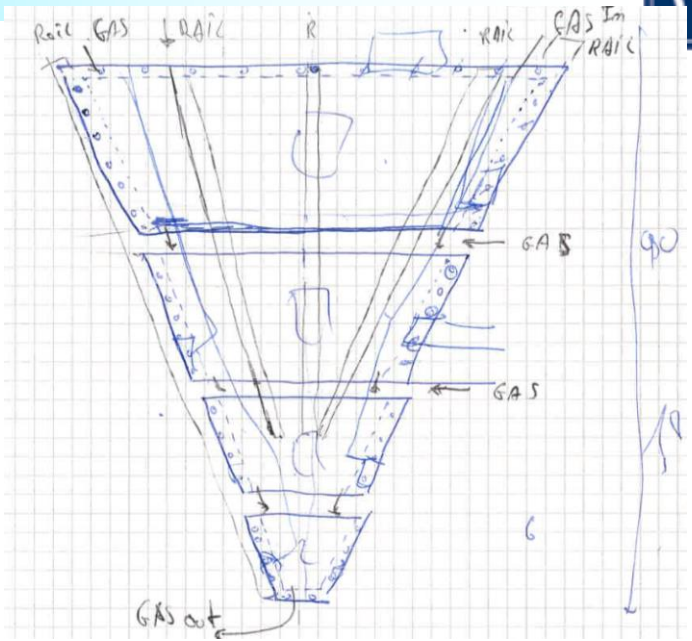

- Knowledge transfer: 50% of GE2/1 GEM Foils produced in Korea
- Long list of lesson learnt in GE1/1 applied to GE2/1:
 - **Mechanics/Technology**
 - Double segmented foils
 - Internal frames layout
 - Pillar
 - **Electronics**
 - Packaged Chips
 - Rigid-flex plugging cards
 - OHs not across GEBs + VTRx Cooling

GE2/1 Module production on-going, detector improvement will be also applied to ME0

Two GEM Foils producers for GE2/1:

- **MPT workshop (CERN)** (same as GE1/1) → M1, M4, M5 and M8 types
- **Mecaro (KR)** (new producer investigated between 2017 and 2019 – approved in Jan. 2020) → M2, M3, M6 and M7 types
- Organized an in-depth internal review with KCMS representatives, Mecaro engineers, project management and Rui directly at the Korean factory

- Excellent experience with the Korean teams from Mecaro and Korea-CMS
 - Large team of experts, almost a constant presence at the factory for the foil validation
 - In-depth inspection and test of all foils in Korea before shipping to CERN for additional cross-check measurements
- In-depth report delivered with every single foil



In GE1/1 Slice test observation of discharge propagation and experienced VFAT3 channel loss

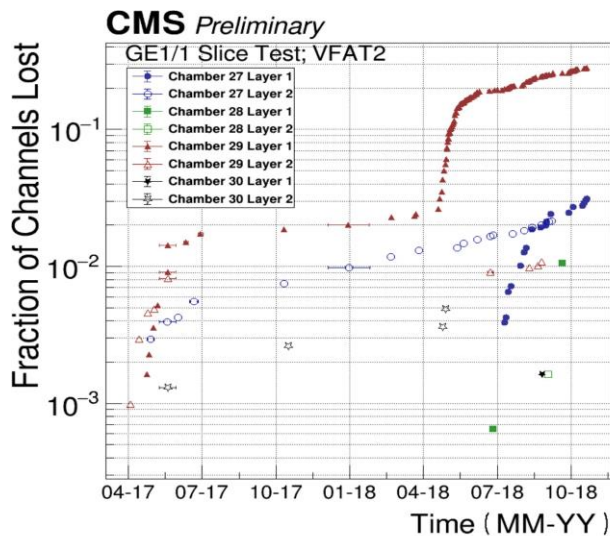

$$\text{Channel loss} \propto \text{Discharge probability} \times \text{Propagation probability} \times \text{Damage probability}$$

The most effective mitigation consists of reducing the probability of discharge propagation

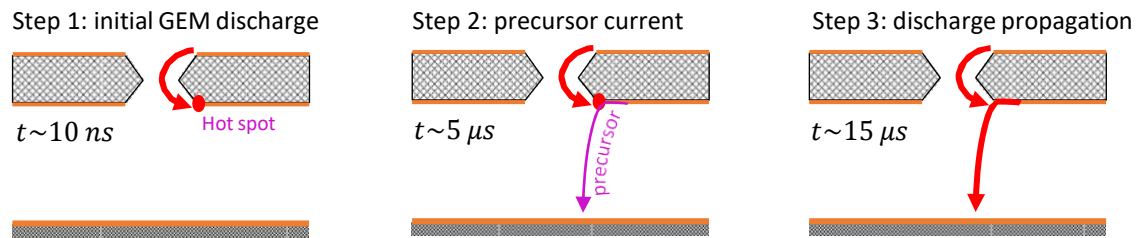

Basic principle:

- HV segments on the top: GEM protection against regular discharges
- HV segments on the bottom: protection against discharge propagation

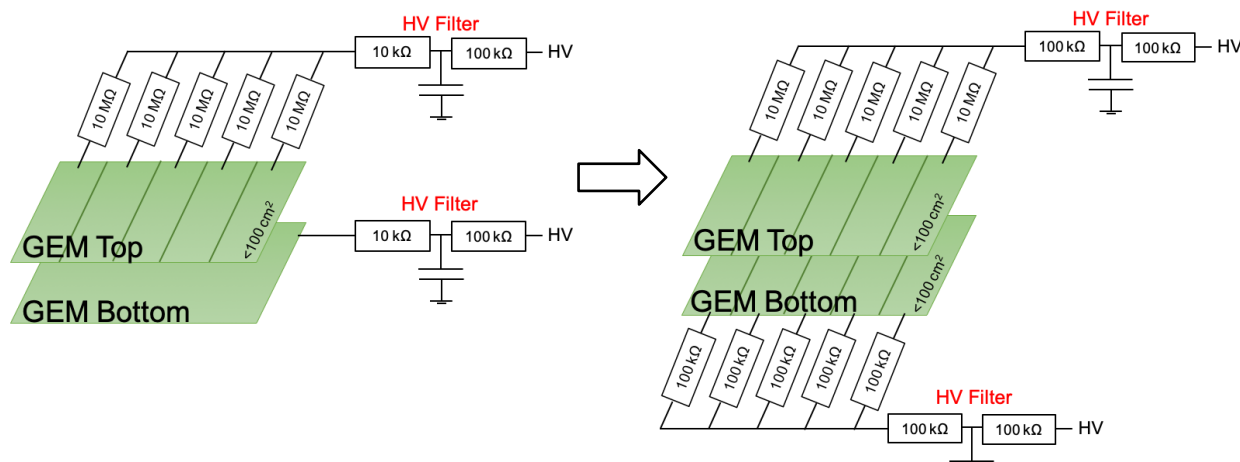

Side Effect - Crosstalk

Reducing the size of the HV segments on the last GEM increases the HF impedance to ground → Induces cross-talk; In case of large signal amplitudes, the corresponding crosstalk signals can trigger the electronics

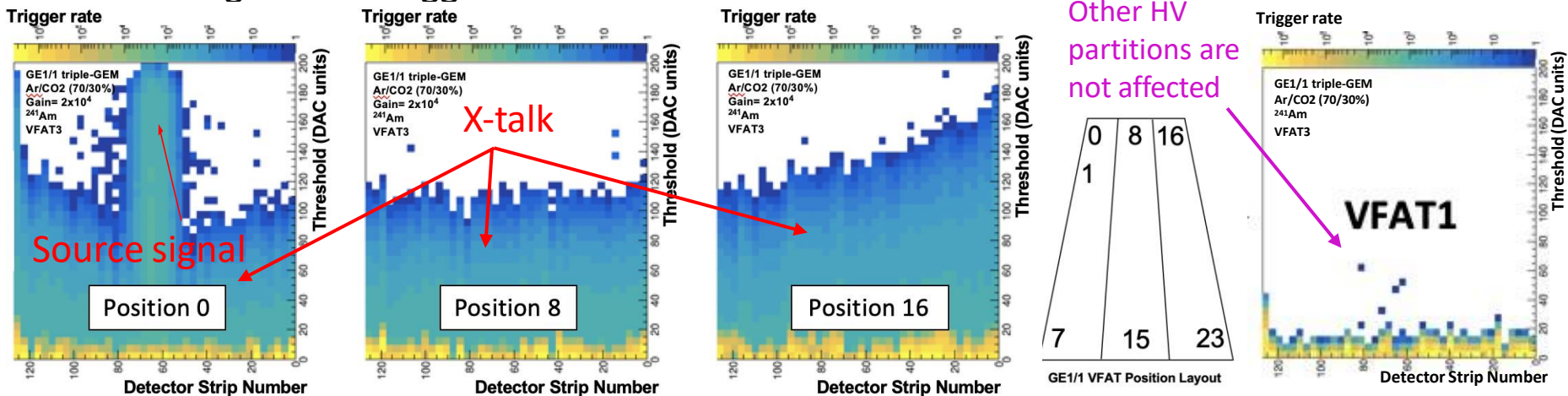

SOLUTION: the "mixed" design

- GEM1 and GEM2 are double-segmented to prevent the **discharge propagation**
- GEM3 is single-segmented to suppress the **crosstalk**

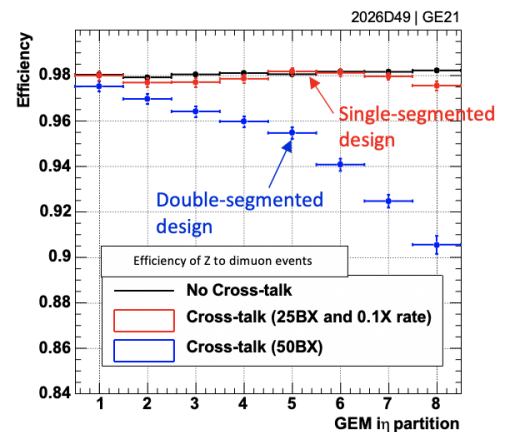
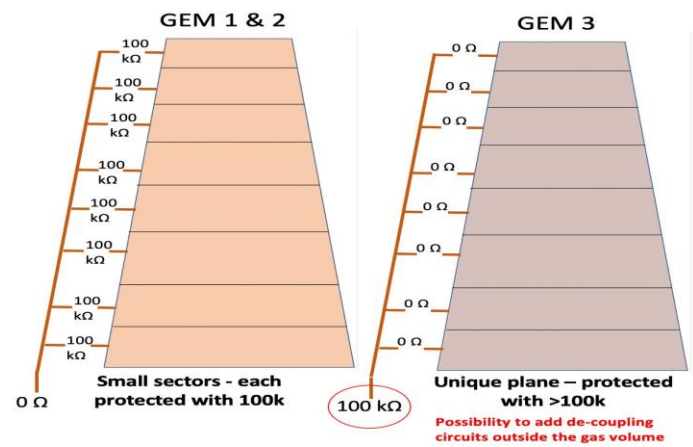

Full description @ <https://indico.cern.ch/event/976526/> Summary of discharge studies in CMS GEM in (Annex D)

Lessons Learnt: Internal Frames

Fraction of Intrinsic Noise from the Internal Frames

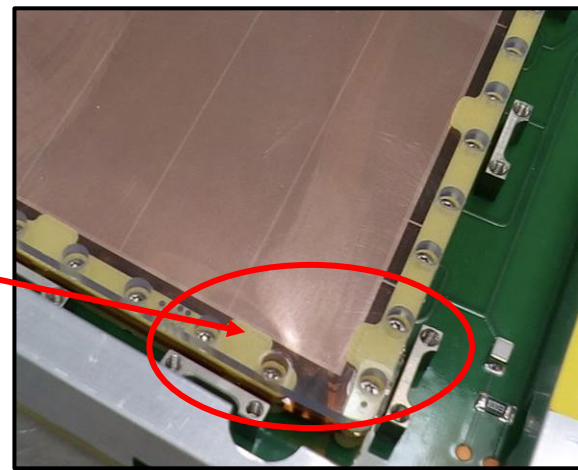
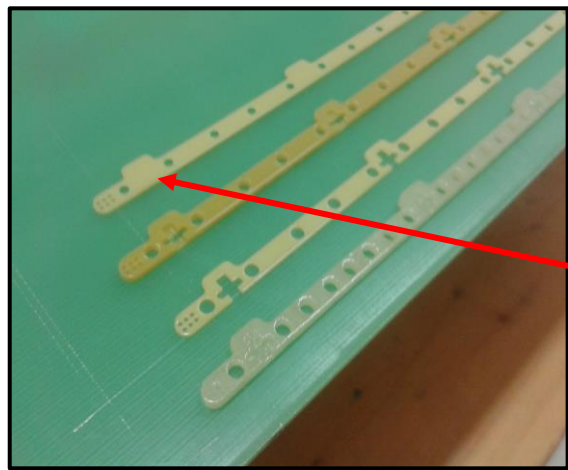
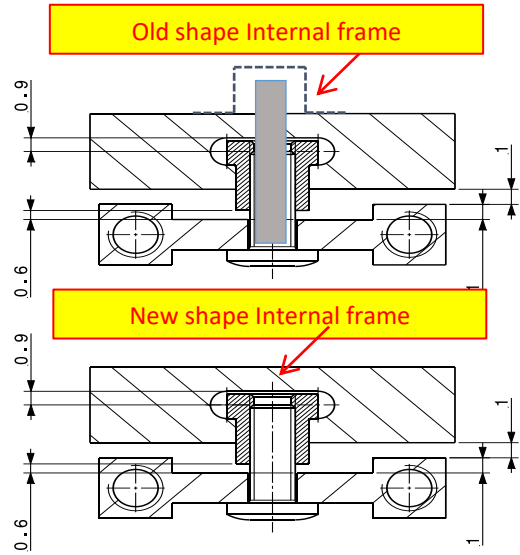
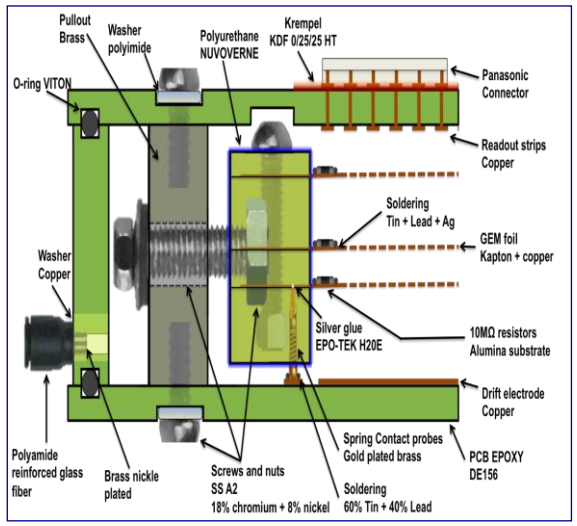
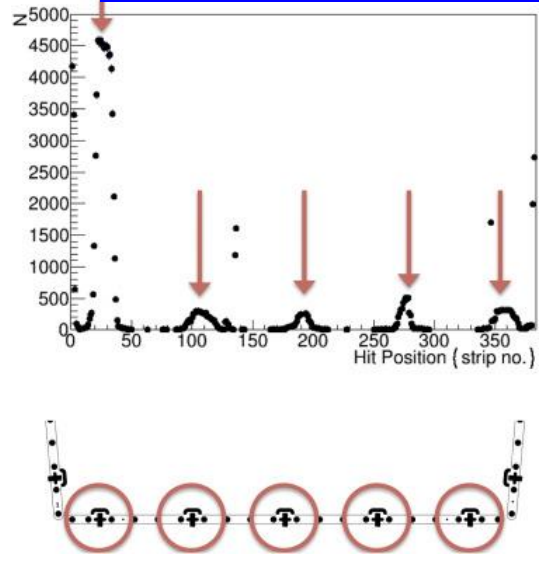

GE1/1 bending:

DRIFT and RO PCBs tend to bend when submitted to stretching forces, causing non-negligible variations of gain across the detector surface
(Different level of non uniformity)

Typical GE1/1 Uniformity

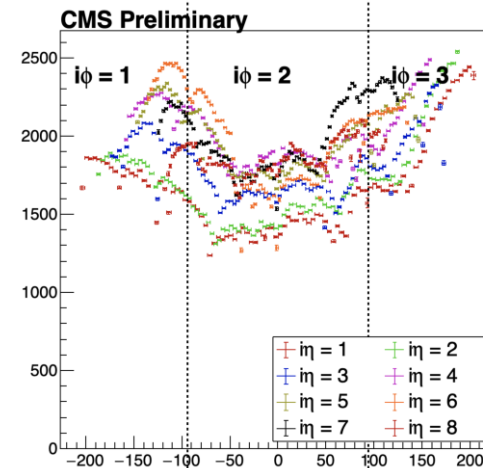

Pillar to constraint Drift Vs RO

FR4 pillar with SS cylinder



Bending inside – eventually deformation of Induction/Drift

Stratified FR4 pillar with SS cylinder

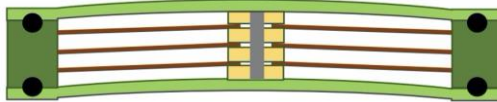
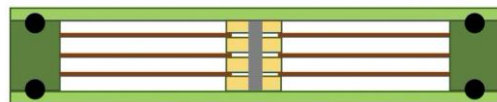

GE2/1 (M2)Uniformity

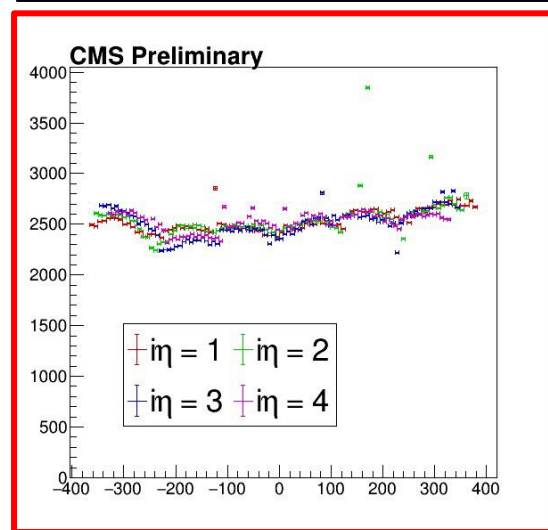

- GEM FE Chips (VFAT3) has more than 500 I/O, extremely dense, makes the wire bonding high demanding in terms of quality of the Hybrids PCB
 - Production of GE1/1 PCB Hybrids painful
 - Moved to VFAT3 chip packaged for GE2/1 production
- Additional protection against discharges

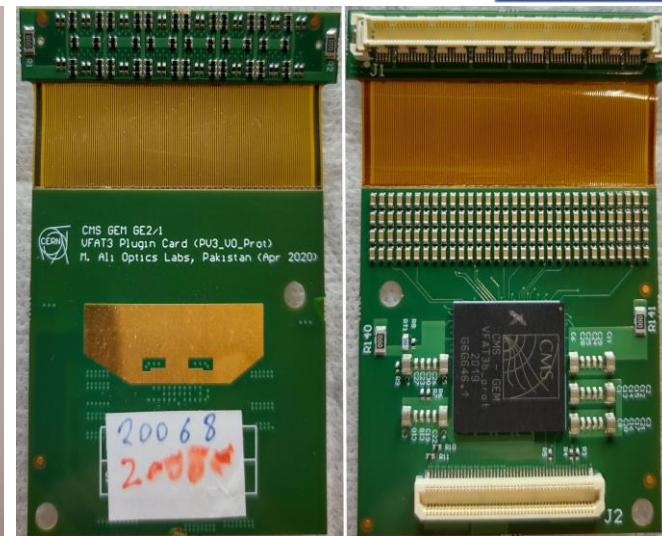
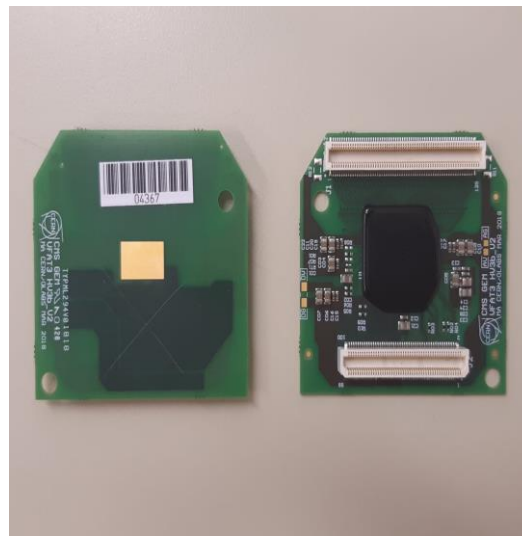

VFAT External protection and de-coupling

Flex PCB allow to absorb for misalignment between FE cards and GEBS

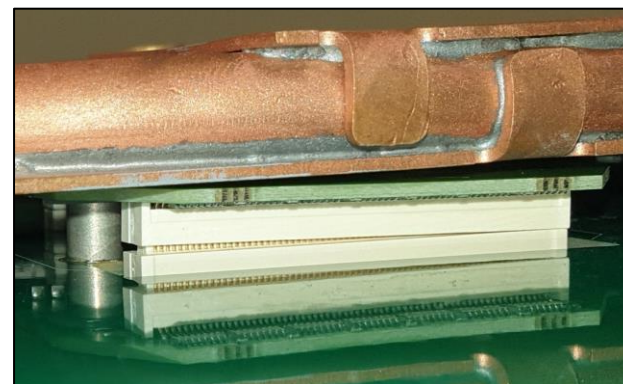
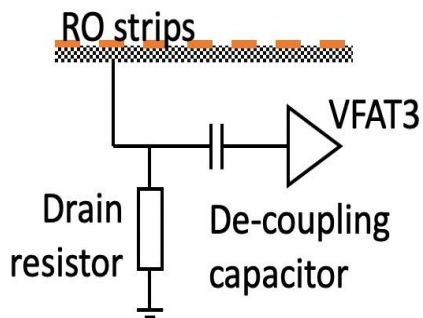

- In GE1/1 OHs sit across two different GEB pieces
 - Mounting connectors alignment not easy, stress is introduced on the electronics
- OH in the center of the GEB of each GE2/1 module

GE1/1 GEB & OH

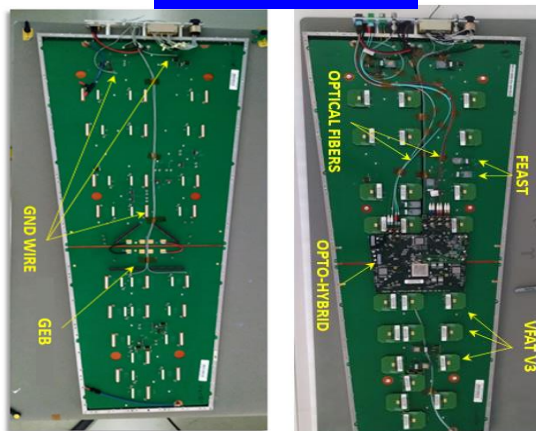

GE2/1 GEB & OH

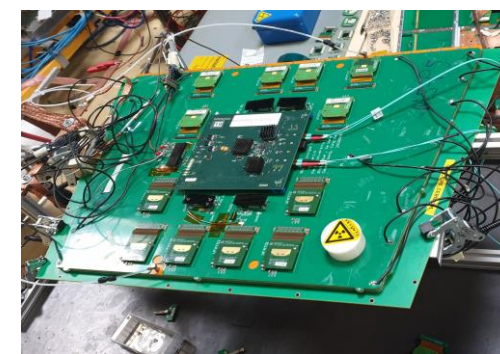

- VTRx's found to be "interesting" behavior, outgassing contaminate the surface of the ROSA ball lens, reducing (some time interrupting) the optical transmission, cooling of the ROSA can mitigate the outgassing

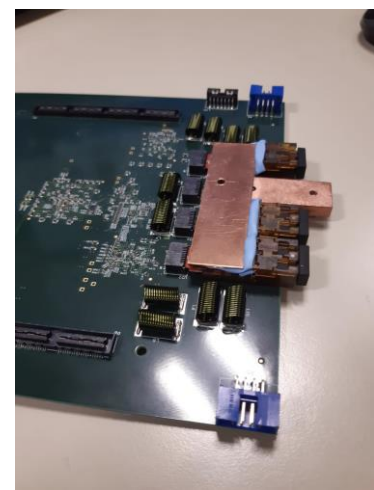
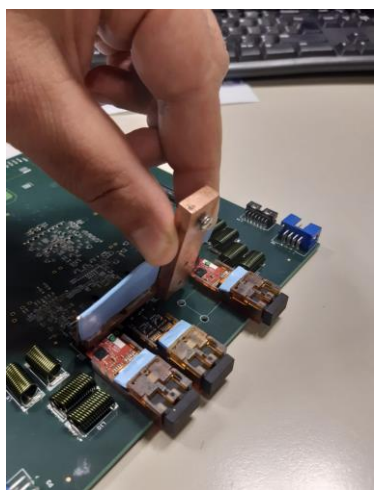
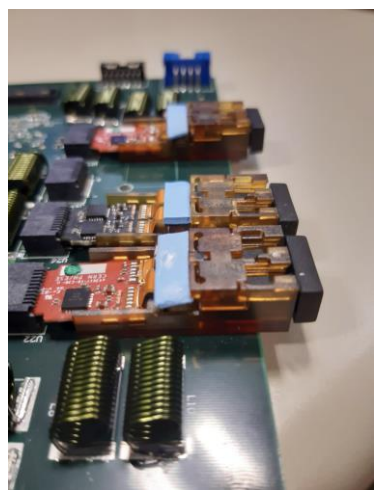

The Curious Case of VTRx Receiver Failures, by [Lauri Olantera](https://indico.cern.ch/event/1099169/) (CERN) <https://indico.cern.ch/event/1099169/>

GE2/1 Demonstrator

As for GE1/1, the GEM project is operating a nearly-final prototype in CMS before the full system in order to:

- test the installation procedures
- develop the DAQ/DCS/DSS tools
- experience real operation

A demonstrator chamber was built, tested and installed in P5 in Nov

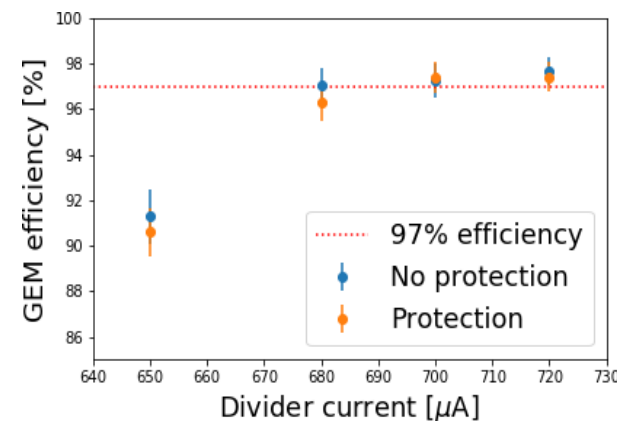
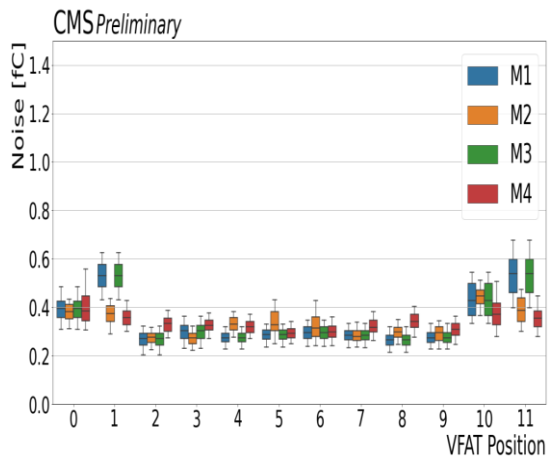

Using final electronics

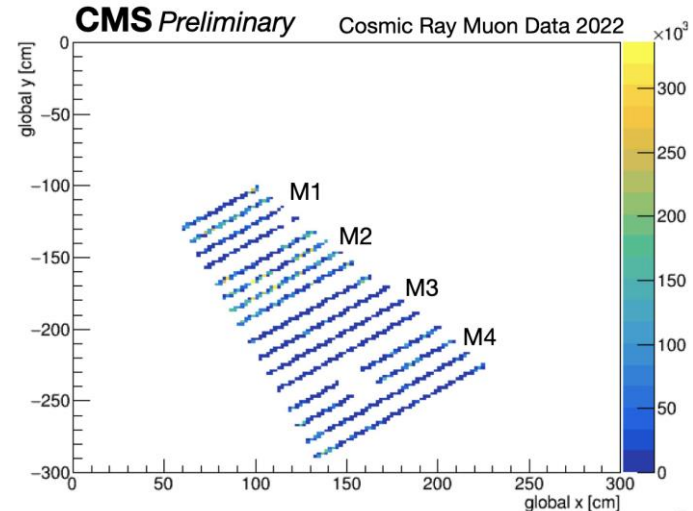
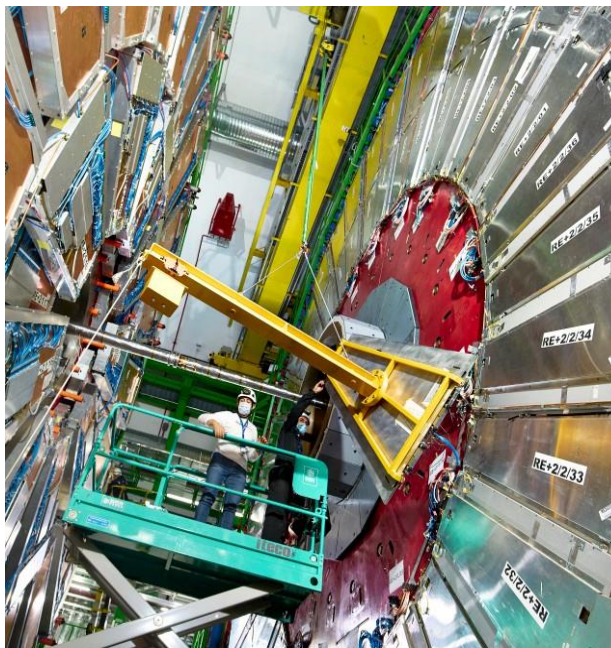

- The ME0 detector system is a layered stack of 6 triple-GEM detectors (70:30 Ar/CO₂ fill gas)
- 18 stacks per endcap (36 total stacks; 216 modules total)
- ME0 detector system to increase coverage from $2.0 < |\eta| < 2.8$
- Module segmented into 8 readout partitions in η and 3 in φ (24 total RO sectors)

Requirements:

- 97% efficiency
- Rate capability of $\geq 150 \text{ kHz} \cdot \text{cm}^{-2}$
- Radiation hardness requirement $> 7.9 \text{ C} \cdot \text{cm}^{-2}$
- Angular resolution $\leq 500 \mu\text{rad}$
- Time resolution 8-10 ns for single layer
- Gain non-uniformity of $\leq 15\%$ inter-/intra-module
- Sufficiently low discharge rate

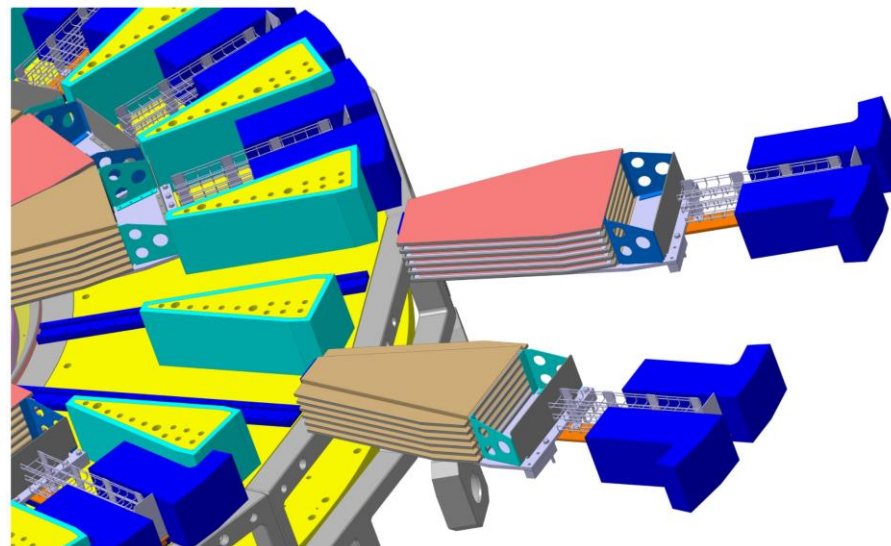
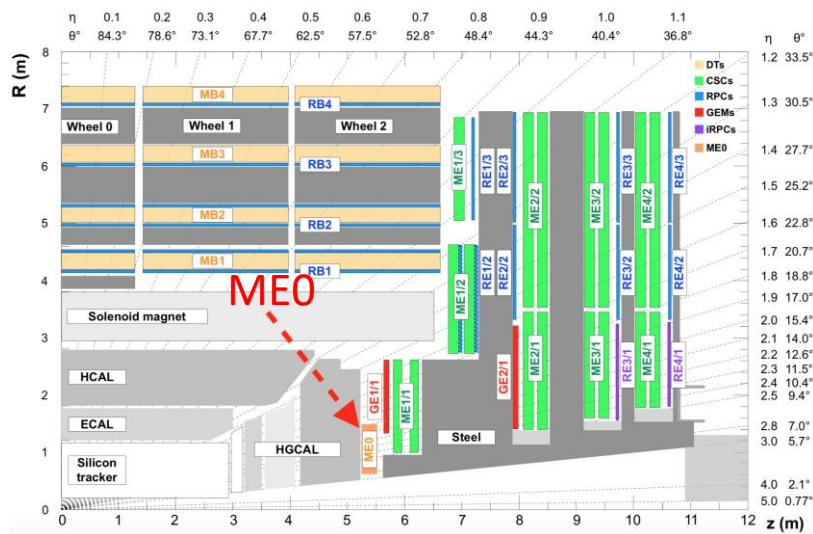

Quadrant of the CMS experiment with ME0

3D rendering of the insertion of two ME0 stacks into the new endcap nose

- Expected Hit Rate \rightarrow [2, **144**] kHz/cm²
- Average primary energy deposit **5.8 keV**
i.e. **200 e-ion pairs**
- HIP: Heavily Ionizing Particle which deposits **>30 keV** in the detector
- HIP rate \rightarrow [0.05, **4**] kHz/cm²

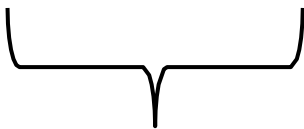

Need to evaluate the impact on detector operation

GEANT4 simulations

- Similar results with FLUKA

Linked, to the rate, challenges:

Discharge rate and propagation (**Annex D**)

Triple GEM Longevities (**Annex E**)

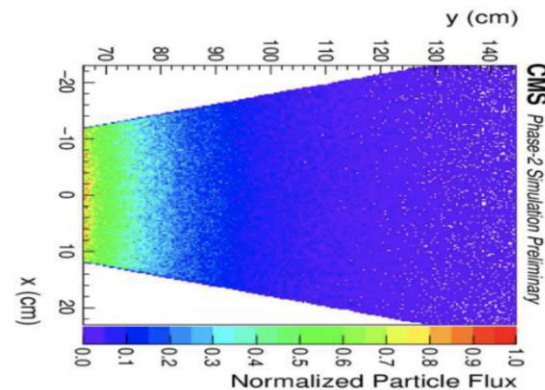
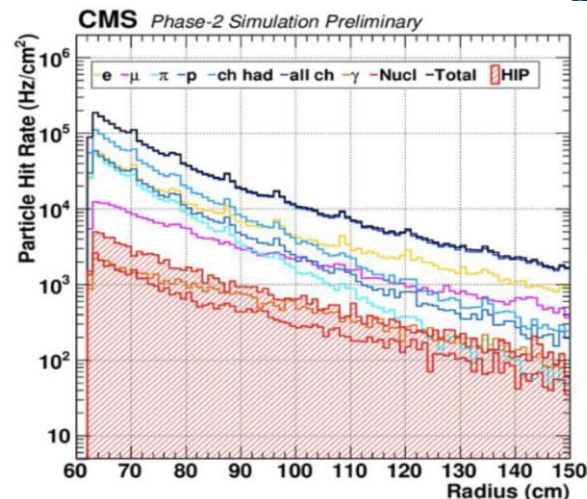

The *rate capability* of GEM-based detectors has been extensively studied in the last decade for different sizes, geometries, and configurations

Ar/CO₂(70/30) – 3/2/2/2mm

P. Everaerts

<https://cds.cern.ch/record/1316179/files/CERN-THESIS-2006-088.pdf>

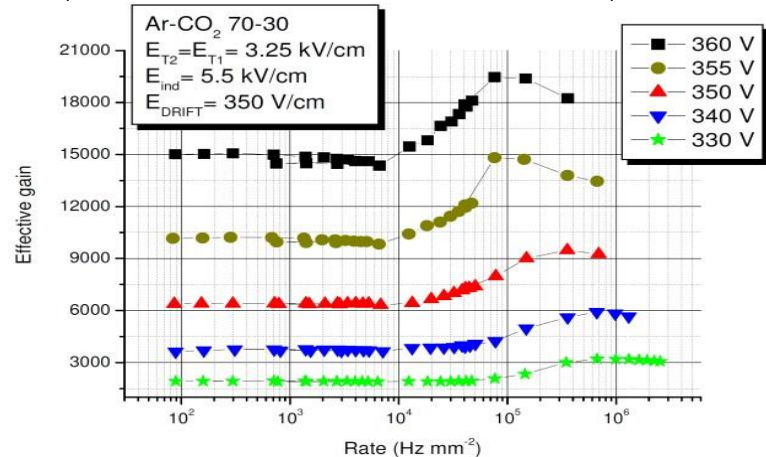

Ar/CO₂(70/30) – 3/2/2/2mm

J.Merlin

<https://cds.cern.ch/record/2155685/files/CERN-THESIS-2016-041.pdf>

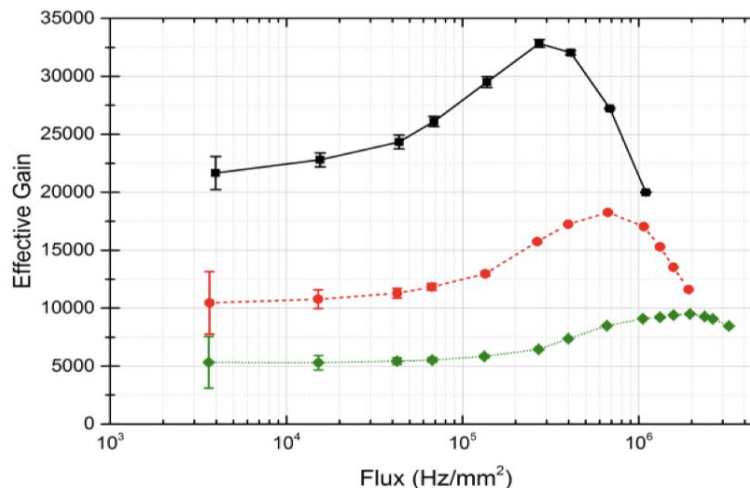
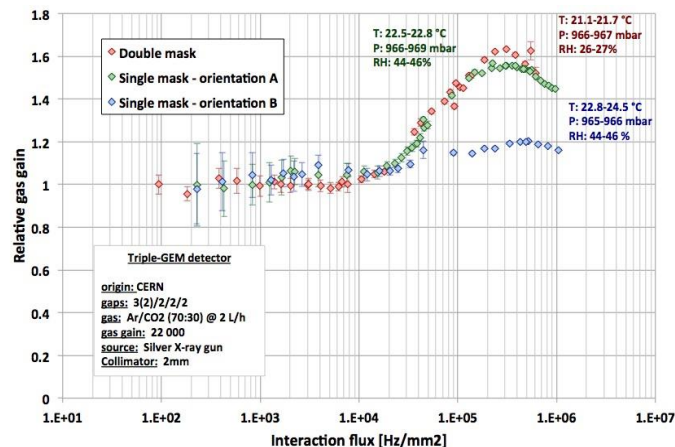

Ar/CO₂(70/30) – 3/2/2/2mm

P. Thuiner

<https://cds.cern.ch/record/2238855/files/CERN-THESIS-2016-199.pdf>

The *rate capability* of GEM-based detectors has been extensively studied in the last decade for different sizes, geometries, and configurations ... but:

Common experimental procedure:

- 1) source: **X-ray generator** (*soft X-ray photons*)
- 2) irradiated area: $\approx \text{mm}^2$
→ reaching **very high X-ray flux**
- 3) gain remains stable up to a flux above MHz/cm^2
→ demonstrating the absence of **space charge phenomena!**

but one observes ...

- 1) a **low ion current** flowing through the **protection resistors** due to the small irradiated area
→ inconsistent with a real experiment
- 2) a **negligible voltage drop** across the GEM-foils
→ as a result: high-rate capability up to tens or hundreds of MHz/cm^2

We need to stress the following points ...

- rather than the space charge, the ion current, flowing through the protect. resistors, strongly affect the detector rate capability!
- a **local irradiation** $O(3 \text{ mm}^2)$ is drastically different to a **global irradiation** $O(3000 \text{ cm}^2)$!

GEM Rate Capability

- Re-evaluating rate capability of triple-GEM detectors by irradiating medium-to-large areas (~100 cm²)
- Detector: **10×10 cm² triple-GEM** detector
 protection resistors **1 MΩ top**, 100 kΩ bottom
 per foil operated in Ar:CO₂ 70:30
 powered by **multi-channel CAEN A1515 (400 pA res.)**
- Source: two silver-target Amptek **Mini-X tubes**
- Readout: Keithley 6487 **picoammeter, 10 fA resolution**

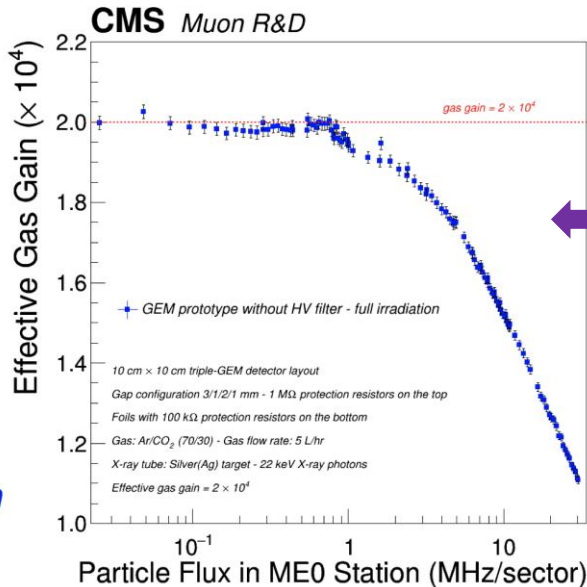
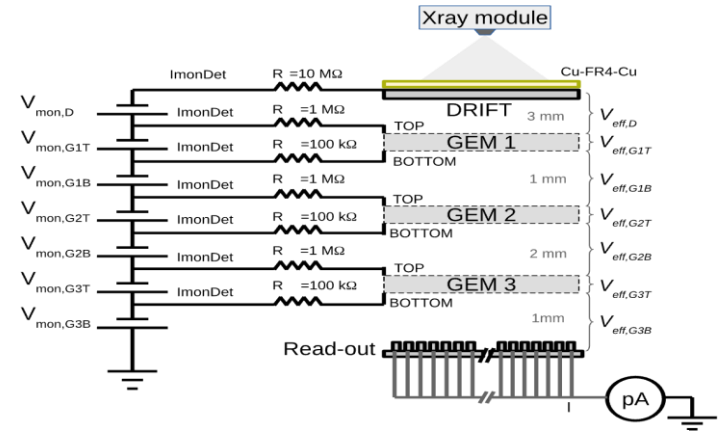

Gas gain drop estimated as:

$$g_{eff} = \frac{i_{anode}(W_{x-ray})}{q_e n_p R(W_{x-ray})}$$

Gas gain drop estimated evaluating the HV drop on the protection resistors due to the current flowing on the electrodes -> possibility to compensate for HV drop

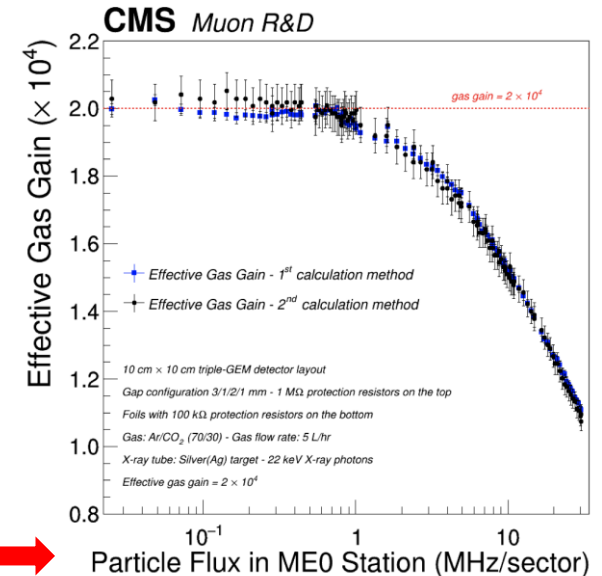

- Applying the correct HV value (correction for HV drop across the resistors) the Nominal Operation Gain is restored.

- Dedicated software with iterative correction designed on purpose

Nominal Operation Gain ($\times 10^4$)

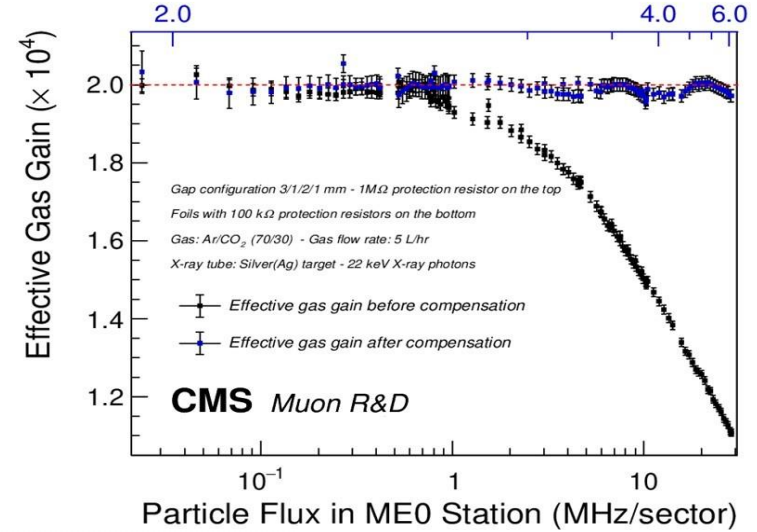

- But in ME0 each HV sectors, as a function of the eta are expected to get different integrated flux, depending on the background shape

- How to compensate different drop with a unique HV channels?

- A) Different HV sector area, to equalize the flux?
- B) Different protection resistors, to equalize the HV drop across the sectors?
- Combination of A) & B)?

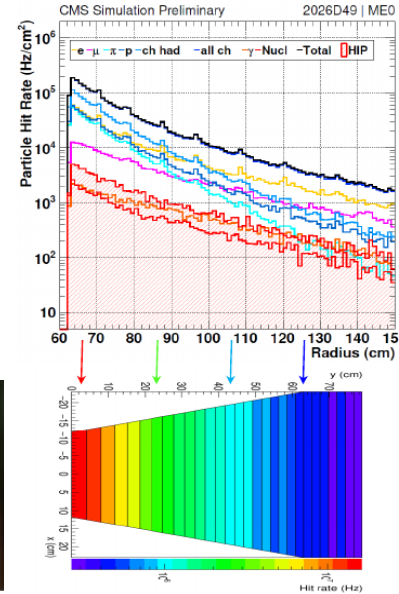

Possible HV drop equalization playing with the HV sectors area (case A)

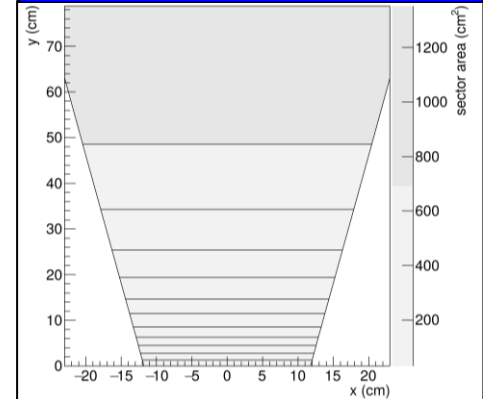

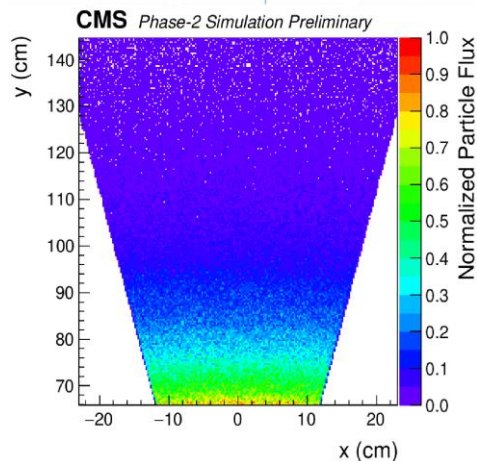
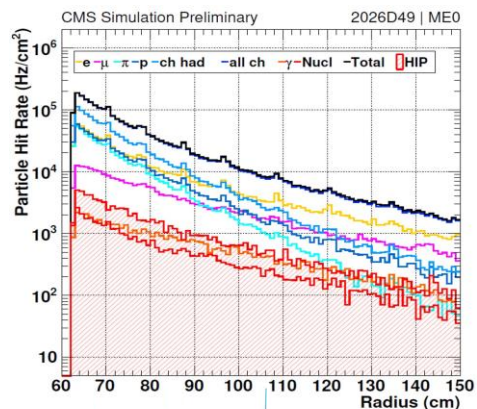

ME0 environment:

- Large rate variation between the coolest and the hottest HV segments (about two orders of magnitude)

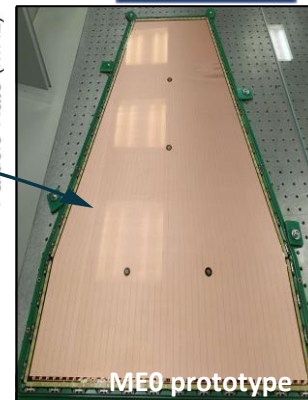
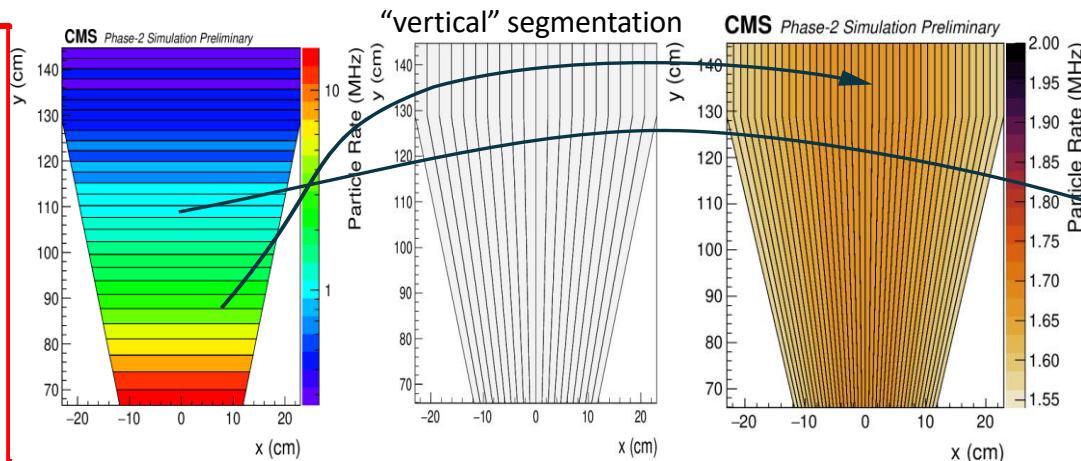

New segmentation introduced

- Change the orientation of the HV segment → “vertical pattern”
- Each segment will see the full BKG gradient i.e. collect the same current as the neighbor segments
 - No dependency with the BKG shape
 - Uniform current across all segment
 - Uniform voltage drop that can be globally compensated
- A first prototype was assembled and tested in summer 2021
 - Reduced protection resistors based on past discharges studies (2 MΩ top, 100 kΩ bottom)
 - Both filter resistance and protection resistance are “merged” to minimize the overall HV resistance



The egg of Columbus

On-going work in 904/GIF++:

- Rate capability comparison between different HV segments
- Gain compensation comparison
- Compensation validated along one HV segment

Next steps:

- Rate capability measurements and gain compensation @GIF++

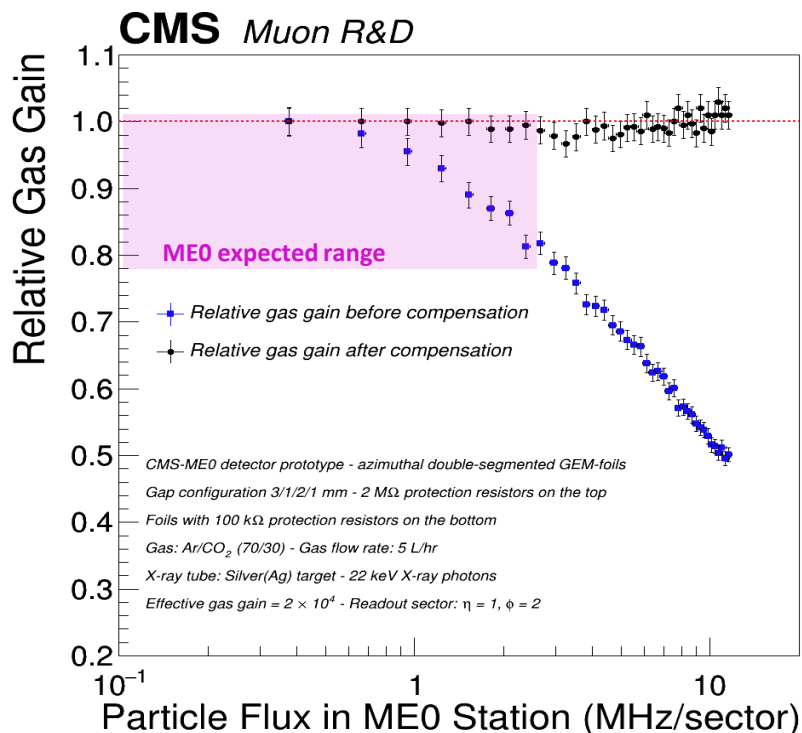
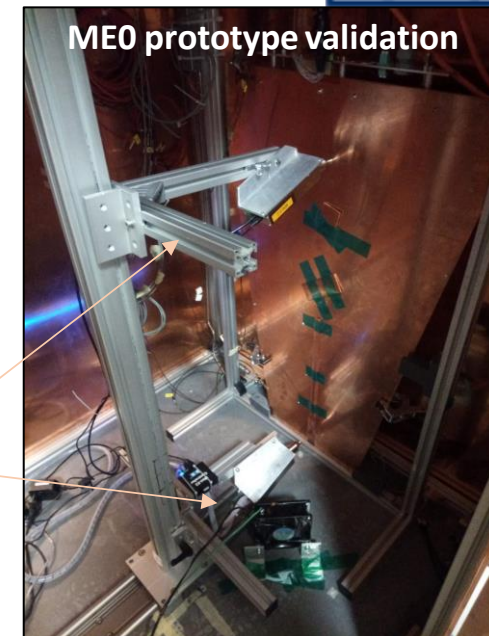

CMS BKG emulation with multiple X-ray sources

Measured effective gas gain as a function of the expected hit rate on the whole electrode area in the ME0 station. The detector under test was irradiated with an X-ray tube: Silver(Ag) target.

The compensation is obtained by applying overvoltages to each electrode separately to compensate the voltage drop induced by the moving charges in the gas.

- resistive HV filter installed: RC filter (2.5 kOhm + 2.2 nF)

■ Motivations

- Simplification of large area GEM foils production
 - Removing GEM holes/Sectors alignment issue
- Possibility to design HV sectors of any possible shape, with reduced dead area between HV sectors
- Improve the GEM foils transparenence
- Remove possible overlap between HV sectorization and readout strips/pad in detectors realized with HV sectors and readout pattern overlapping along the same coordinate
- Expect to improve efficiency and uniformity within the entire detector area covered by GEM foils
- Prove that the single mask technique allow to master GEM foils without any issue against HV distribution stability
 - In the past similar R&D based on GEM foils produced were abandoned due the GEM foils instability against HV distribution (Sparks)

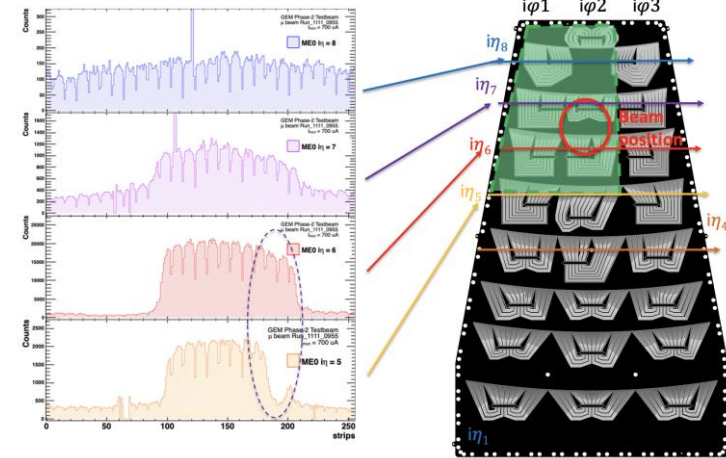
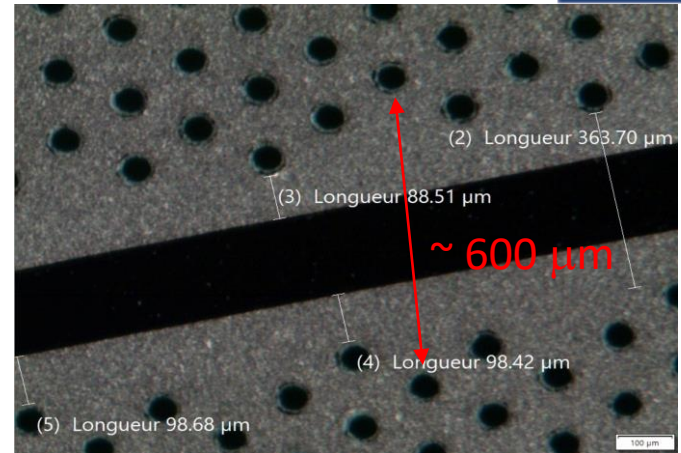

CMS-ME0 Module, equipped with GEM foils “Blank” sectorized along the RO Strips. Longitudinal HV segmentation clearly observed in occupancy plot

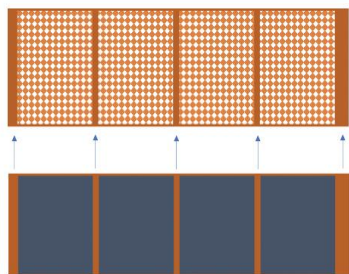
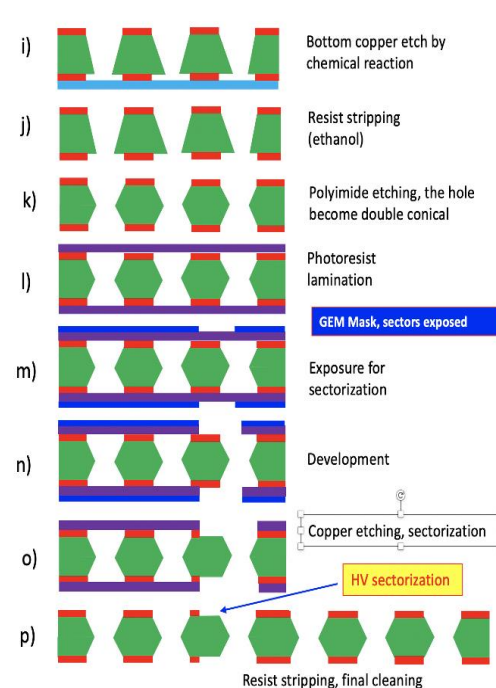
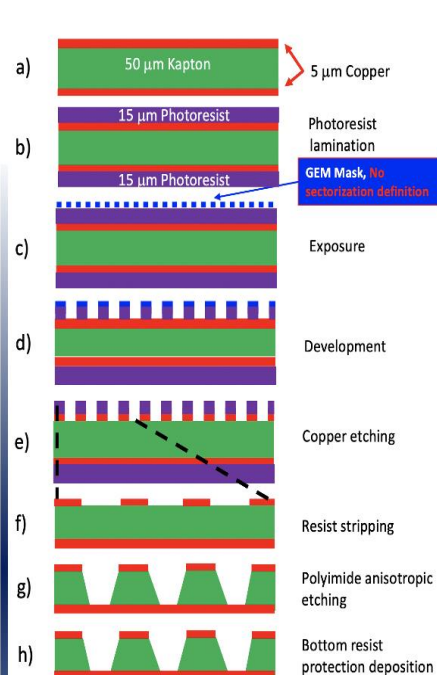
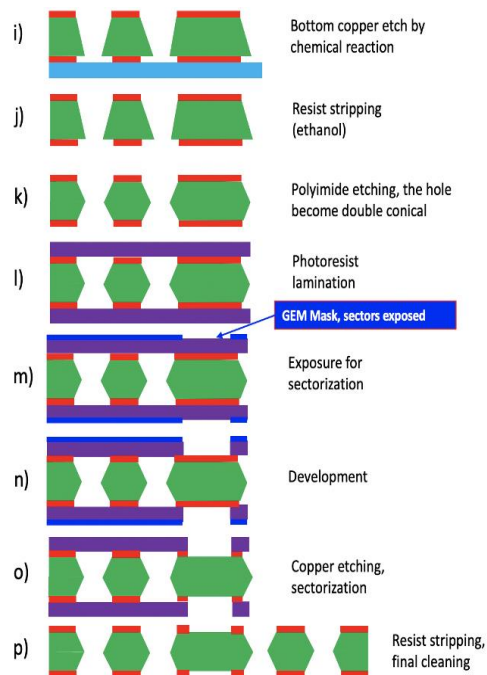
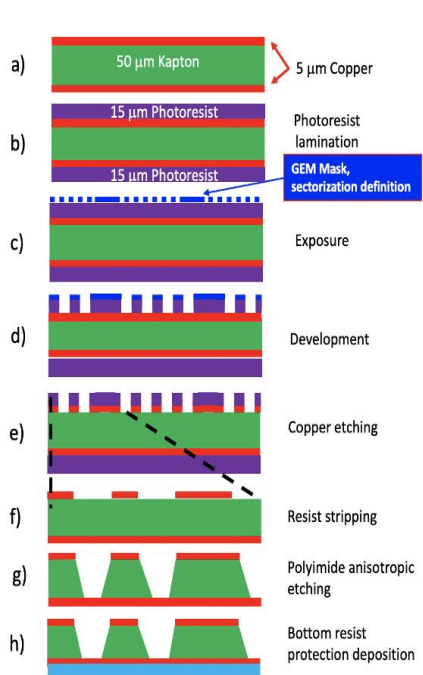

Zoom on step "m"

GEM Mask:
sectorization pattern defined

Sectorization mask and holes
pattern must be carefully aligned

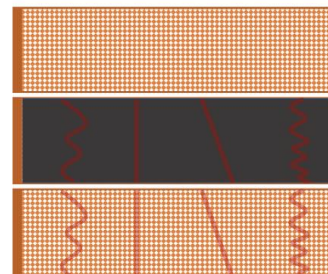
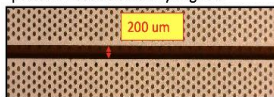

Zoom on step "m"

GEM Mask:
• No sectorization pattern defined

Sectorization mask:
• HV sector can assume any shape without alignment mast problem
• GEM holes can be partially surrounded by copper

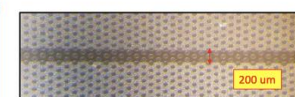

Triple-GEM detector prototype

- ✓ active area: 10 cm × 20 cm
- ✓ gas configuration: 3/1/2/1 mm
- ✓ double-sided random segmented GEM-foils
- ✓ operating gas mixture: Ar/CO₂ (70/30) - 5 l/h
- single-mask photolithography technique
- 200 μm width copper free gaps produced at an angle of ~ 100 μm w.r.t. the hole pattern
- 1MΩ prot. resist. on top, 100kΩ prot. resist. on bottom

Double-sided random segmented GEM-foils

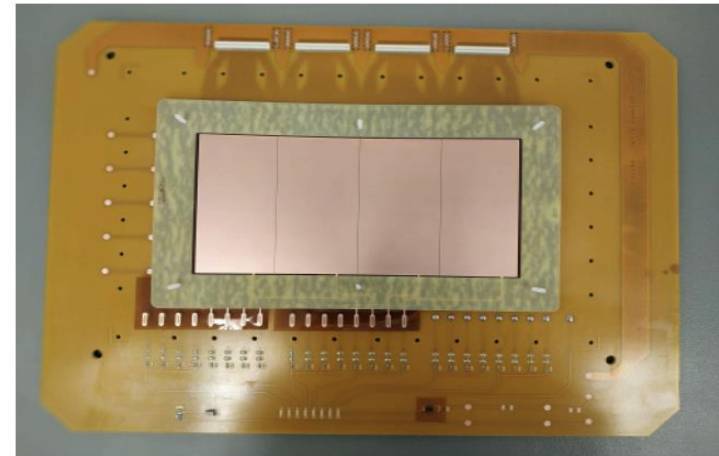

Optical inspection results:

- ✓ optical inspection by backlight → good
- ✓ holes uniformity → good
- ✓ holes diameter → good

copper rings diameter: $\varnothing_{Cu} \sim 74 \mu\text{m}$
 (required specs $70 \pm 5 \mu\text{m}$)
 polyimide rings diameter: $\varnothing_{PI} \sim 53 \mu\text{m}$
 (required specs $50 \pm 5 \mu\text{m}$)

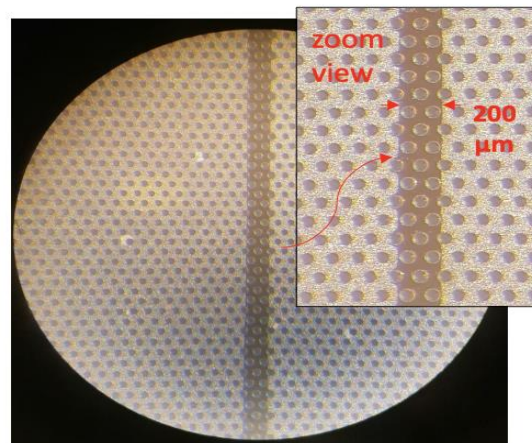

Microscopic pictures of the random electrode sectorization

To be verified:

- ✓ Possible copper delamination risk in the vicinity of the insulating region between adjacent sectors
- ✓ Minimize the electric field distortion and recover the potential efficiency loss at the sector gaps

High Voltage and Linearity Test in pure N₂

- ✓ High voltage and linearity test aims to determine the current voltage curve in order to identify possible malfunctions, defects in the HV circuit and intrinsic noise rate
- ✓ High voltage test includes the operating of the chamber at HV values leading to electric current values exceeding 40% the nominal ones as required by a final experiment

NO trips of the power supply or disruptive events were recorded

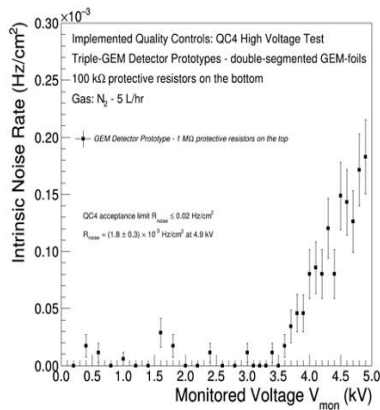
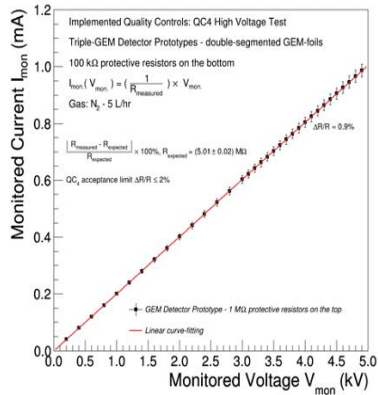

Measurement of the Effective Gas Gain in Ar/CO₂ (70/30)

- ✓ Effective gas gain for the prototype with random electrode sectorization comparable to triple-GEM detector with standard sectorization

Effective gas gain in Ar/CO₂ (70/30) of about 2×10⁴ at 680 μA of equivalent divider current (i.e. drift voltage 3.2 kV)

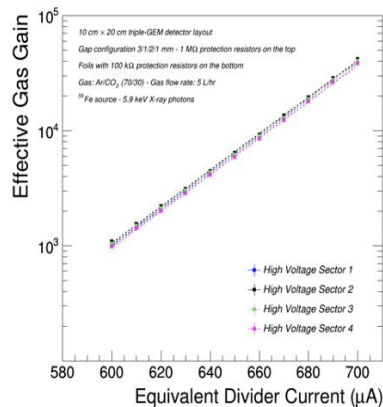

Gas Gain Uniformity

Gas gain map of the triple-GEM detector. Collimated 5.9 keV ⁵⁵Fe source (~ 2 mm²) used to scan the 10 cm × 20 cm area at a 3 mm (x-coord.) × 4 mm (y-coord.) grid

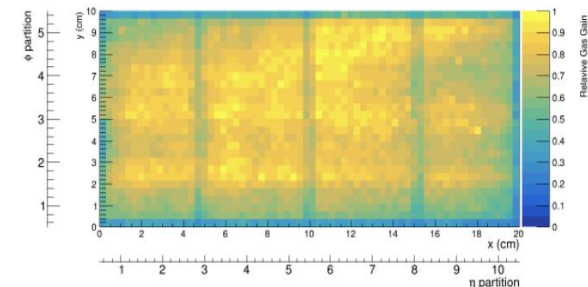
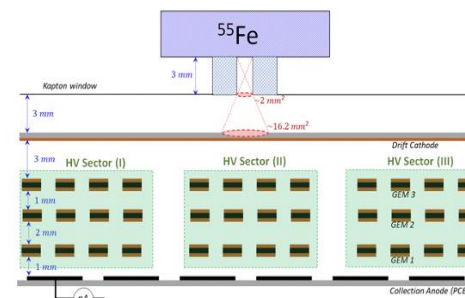

Energy Spectrum in Ar/CO₂ (70/30)

Typical energy spectrum of ⁵⁵Fe source: clean separation of the main photopeak and the Ar-escape peak is achieved

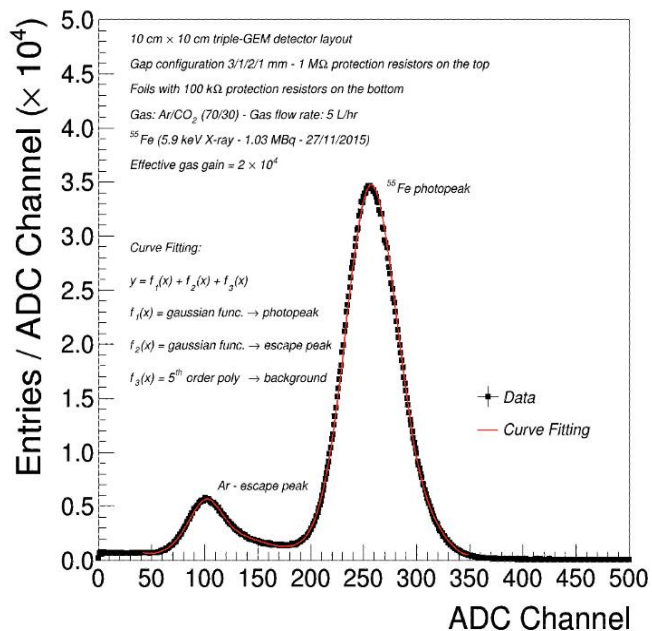

Energy resolution in Ar/CO₂ (70/30):
 $FWHM/\mu \sim 15\%$

High Voltage Stability in Ar/CO₂ (70/30)

- ✓ If a sector of the GEM-foils is in short-circuit, the current flowing through the top and bottom side of the foil increases
- ✓ A short circuit is introduced in the sector 2 of GEM₁ (or GEM₂, or GEM₃)

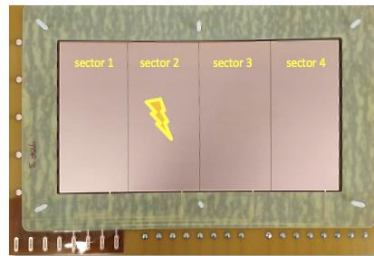

- ✓ The current flowing through the other sectors and foils is proved to be stable. No abnormal leakage current or discharges were detected during several hours of measurement

Energy Spectrum in Ar/CO₂ (70/30)

Energy spectra measured after positioning a ⁵⁵Fe source over a sectors adjacent to the short-circuited one are not affected by the presence of the short

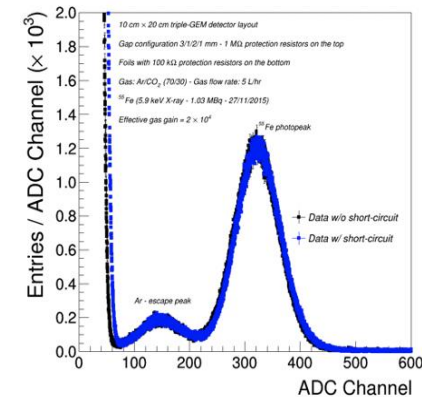
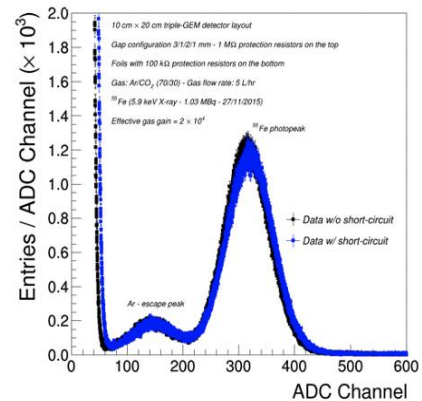
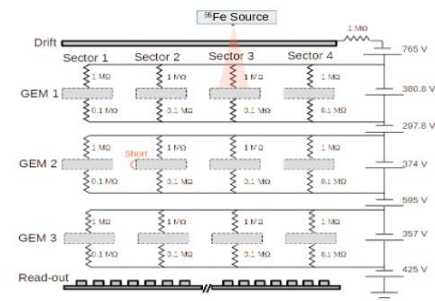

Efficiency measured in GE2/1 –M1 Module

Zoom on “Standard Segmentation”

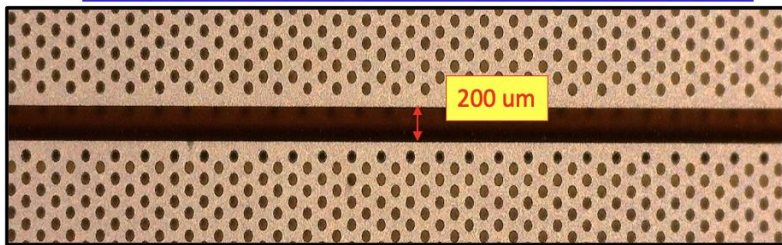

Efficiency in 10x20 prototype

Zoom on “Random Segmentation”

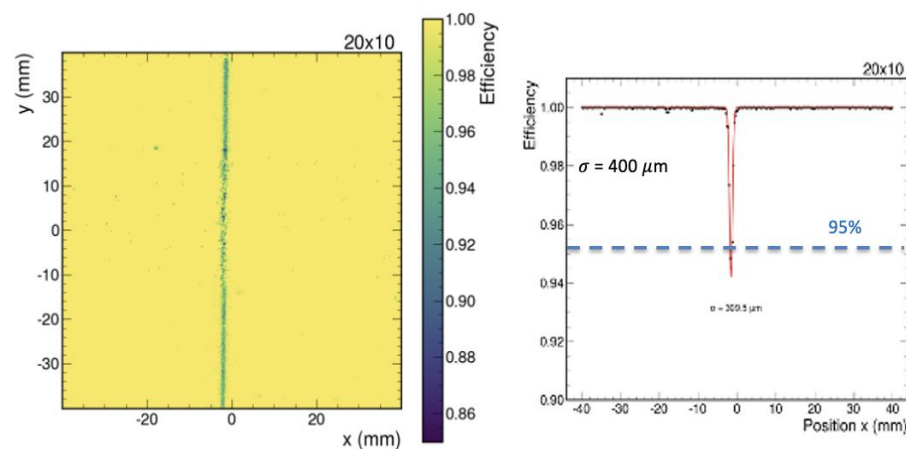
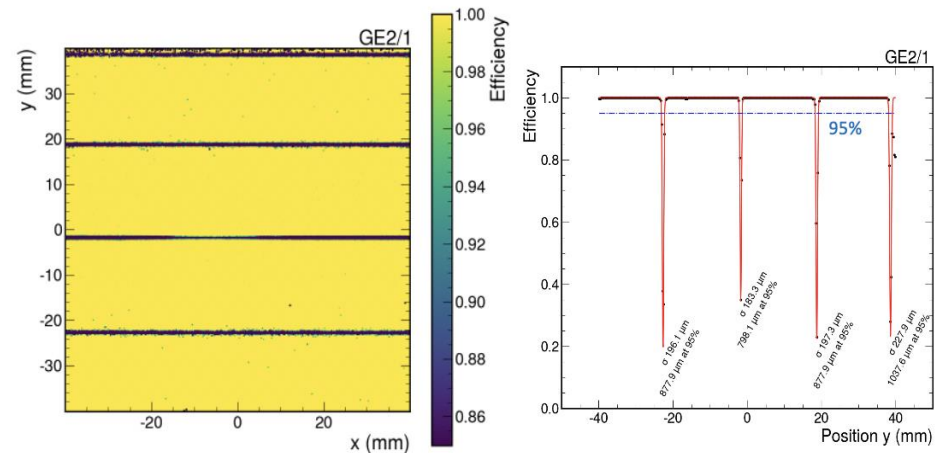
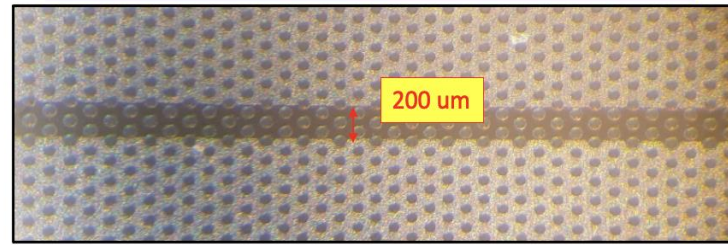

- Efficiency measured in CMS - GE2/1 chamber operated at GAIN: 2E4, instrumented with Standard Segmented GEM foils
- Sigma Efficiency dip due to the HV segmentation is 200 μm (Dip @ 95%: $w = 900 \pm 100 \mu\text{m}$)
- Efficiency drop also up to ~20%

- Window of 9cm x 9cm, in 10x20 chamber with Random Segmented foils defined by the Tracker coverage
- Sigma Efficiency dip due to the HV segmentation is 400 μm (\ll width 95% efficiency)
- Efficiency drop very limited ~94%



Summary



- A lot of work has been done in the last 15 years, but even more is still in front of the CMS-GEM collaboration
- The challenges posed by the CMS-GEM projects have been and excellent stimulus for the general development of the GEM technology
- GE1/1 project as been delivered during LS2 and now must be correctly operated in LHC Run3 to deliver good physics data
- Experiences acquired with GE1/1 projects fully reversed in GE2/1 and ME0
- GE2/1 is in full production, expected to be installed in the YETS 2023/24 & EYTES 2024/25
- ME0 design refinement in progress, the harsh environment in which the ME0 chambers will be operated pose new challenges for the triple GEM-GEM technology
 - Specific improvements in matter of rate capabilities, gain uniformity, discharge protection have been studied and introduced

**Thank you for your attention,
and very happy to be with you in person!**

GE1/1 Taking data @13.6 TeV



CMS Experiment at the LHC, CERN
Data recorded: 2022-Jul-05 14:48:56.743936 GMT
Run / Event / LS: 355100 / 51596902 / 53

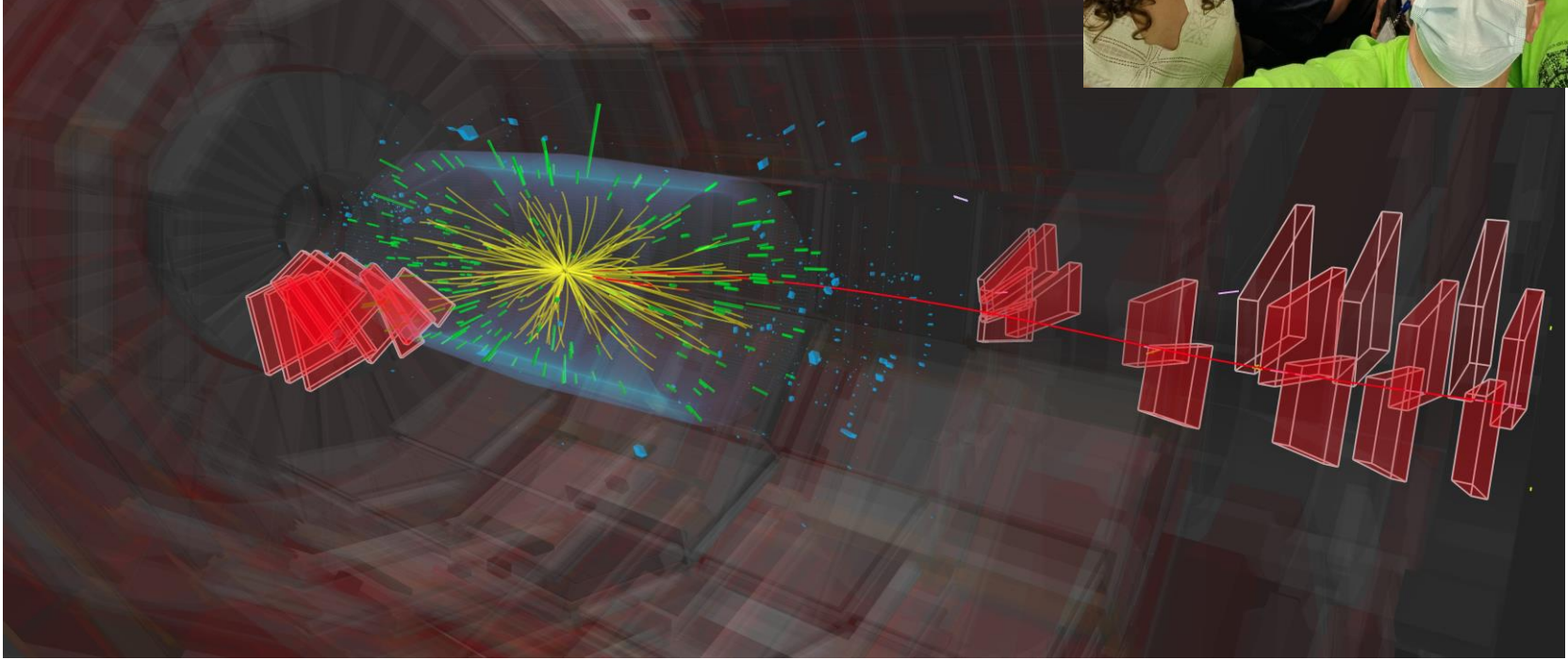

- **Annex A** : GE1/1 Components QA/QC
- **Annex B** : GE1/1 Chamber Assembly
- **Annex C** : GE1/1 Chamber QA/QC
- **Annex D** : Discharges studies with CMS-GEM Chambers
- **Annex E** : Aging studies with CMS-GEM Chambers

QC1 - Detectors Components Inspection and Qualification

All the GE1/1 detector components produced by industrial companies are delivered to CERN where they are immediately verified for defects and tested

→ *Internal / external frames*

- Optical inspection to identify possible cracks, mechanical unconformities and manufacturing defects on the epoxy glass structure
- Measurements of the width and depth of the grooves along periphery of the external frame that will accommodate the Viton O-ring in order to ensure greater degree of the gas-tightness of the detector

→ *Viton O-ring*

- Measurements of the external diameter in order to ensure a correct coupling between the O-ring and the external frame and ensure a correct gas-tightness

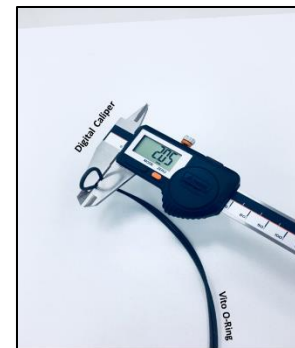
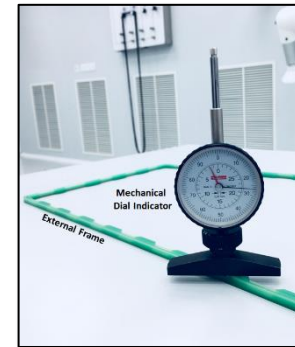

QC1 - Detectors Components Inspection and Qualification

→ Drift Board

- Optical inspection to identify possible mechanical damage and surface anomalies on the drift electrode and its planarity

→ Readout Board

- Optical inspection to check the planarity of the readout board and possible macroscopic scratches and defects on the readout strips or Panasonic adopters for signal readout
- Connectivity test in order to inspect the readout board for possible shorts between strips or open strip-readout connections
- The readout board under test is rejected if:
 - **short circuit ≥ 4**
(in the whole readout board)
 - **faulty channels ≥ 3**
(inside the same Panasonic adapter)

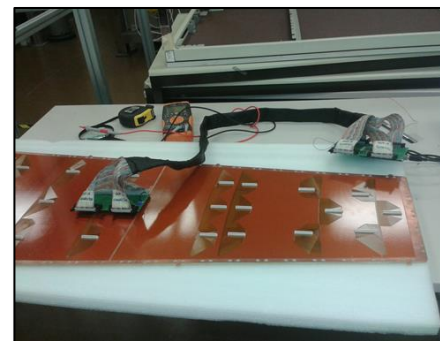

Connectivity Test

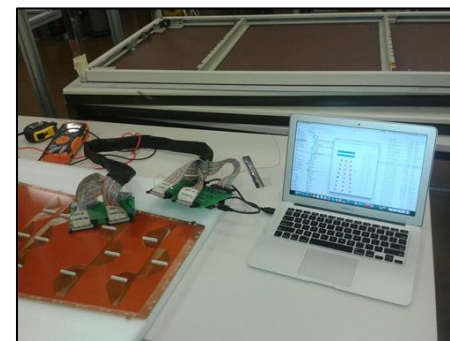

Connectivity Test



Microscopy photos of the readout strips showing some examples of defects and short circuits between the readout strips.

QC2 - Leakage Current Test

The QC2 - leakage current test aims to determine the quality of a GEM-foil by measuring the maximum leakage current flowing on the surface of the GEM-holes.

GEM-foils produced in the CERN PCB workshop are delivered to CMS GEM clean room, where they undergo to dedicated QA/QC test:

1. Optical inspection to identify macroscopic defects on the copper or Kapton layers, which could increase the probability of electrical breakdown and/or short circuit
2. Dedicated quality control test (QC2 - Leakage Current test) to measure the **leakage current** and possible **discharge**

When a voltage is applied across the GEM-foil, a current flows from its top to bottom due to the surface conductivity of the Kapton which is known as **leakage current**

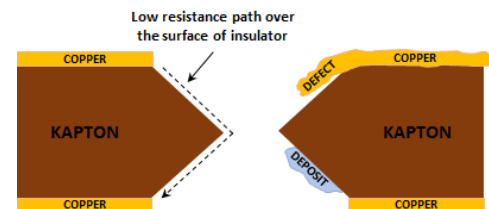

Presence of dust, pollution or defects could provoke an increase the leakage current flowing through the polyimide surface

It is possible determinate the integrity of the GEM-foils by measuring this leakage current and/or possible discharge

QC2 - Leakage Current Test

→ QC2 Fast Term Stability

- The first step consists of applying 550 V to the GEM-foil and measure the leakage current between the top and the bottom electrodes and the number of possible discharge
- QC2 Fast Term Stability is performed both in CERN PCB workshop before the foils delivered and as soon as the foils arrive in the CMS - GEM QA/QC lab.
- The QC2 Fast Term Stability is performed with a Multi Mega-ohmmeter (Megger) over a period of 10 min. in air
- The GEM-foil is accepted if:
 - **impedance $\geq 10\text{ G}\Omega$**
 - **number of discharge ≤ 2**
(during the last two/three minutes of test)
- If the number of discharges exceed the limit, the GEM-foils have to be re-cleaned with antistatic roll or, in the worst case, with *DI water* in ultrasonic baths

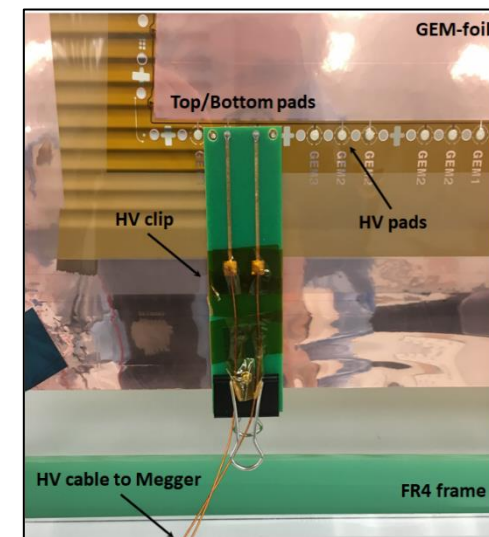
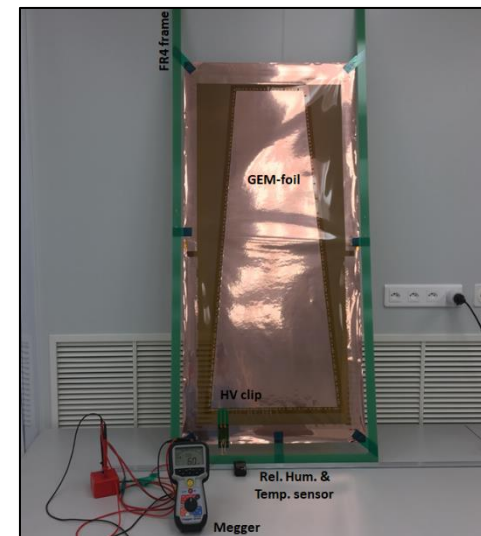

QC2 - Leakage Current Test

→ QC2 Long Term Stability

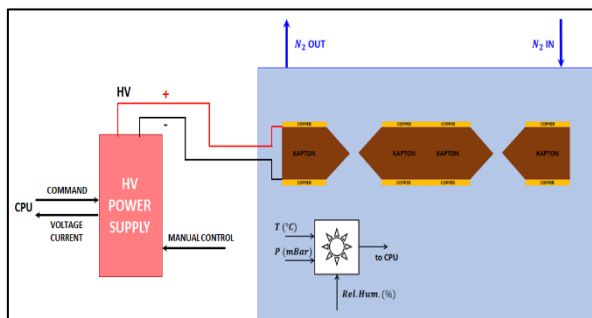

Schematic view of the QC2 long term stability setup

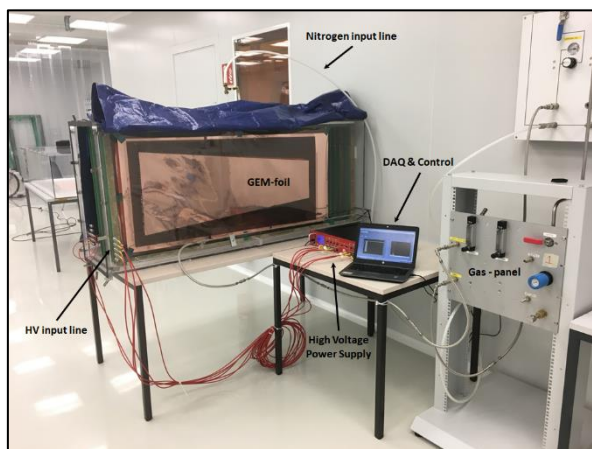

- Goal of the QC2 Long Term Stability test is the ultimate certification of the GEM-foils before the installation in the GE1/1 detectors
- QC2 Long Term Stability test is conducted using CAEN HV module with 50 pA of current resolution acquired through *LabView* based software
- The GEM-foils are kept at low humidity level ($\sim 7\%$) in a dedicated box by flushing in pure dry Nitrogen (N_2 flow rate ≈ 50 L/hr)
- GEM-foils are rejected if the test is failed more than three times (see next slide)
- GEM-foils fails the test are promptly sent back to the CERN-PCB workshop for cleaning

QC2 - Leakage Current Test

→ QC2 Long Term Stability

The Long test is divided into preliminary characterization phase and 3 steps with data monitoring:

- During the “first gas flushing period” $\sim 36/48$ hr, needed to reduce the relative humidity up to $\sim 7\%$, the GEM-foils are kept at 500/550 Volts, (Current limit 100 nA, trip time 1 sec)
- **Step 1:** Slow ramp up to 500 V, plateau monitor at 500 and 550 Volts; step is passed if no discharges occurred for 10 min. for each HV value
- **Step 2:** HV fixed at 600 Volts, current and discharges are monitored; step is passed if no discharges occurred for 15 min. or no more than two discharges during the last 6 hr (Current limit 50 nA, Trip Time 0 sec)
- **Step 3:** Voltage switches between 100 Volts and 600 Volts, to evaluate a possible off-set in the current measurement

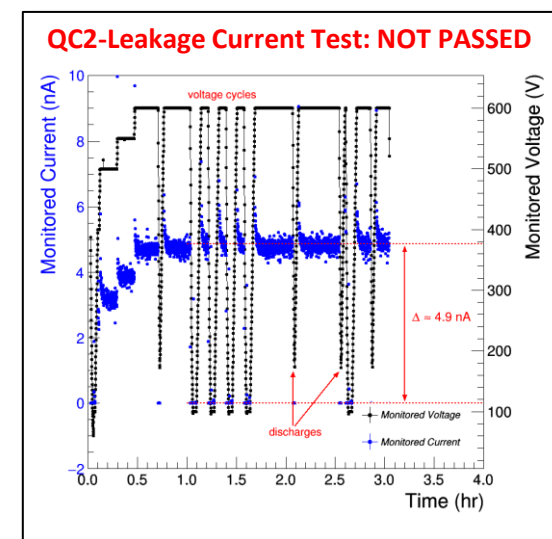
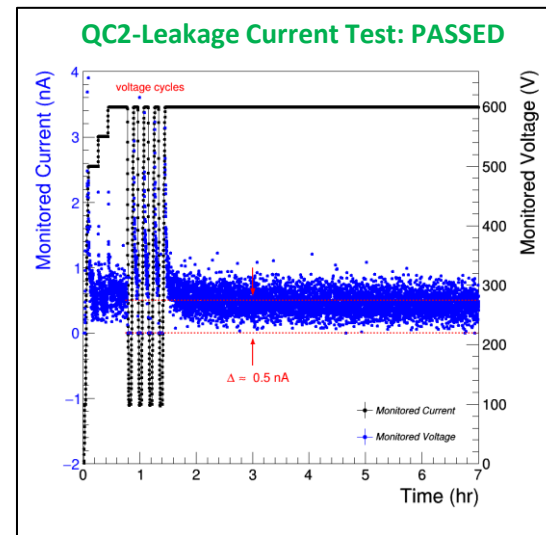

Annex B (GE1/1 Chamber Assembly)

Step 1: all the tools are prepared and carefully organized for the assembly (left). The working table, made of PolyMethyl MethAcrylate (PMMA), is cleaned with an anti-static paper and ethanol (right).

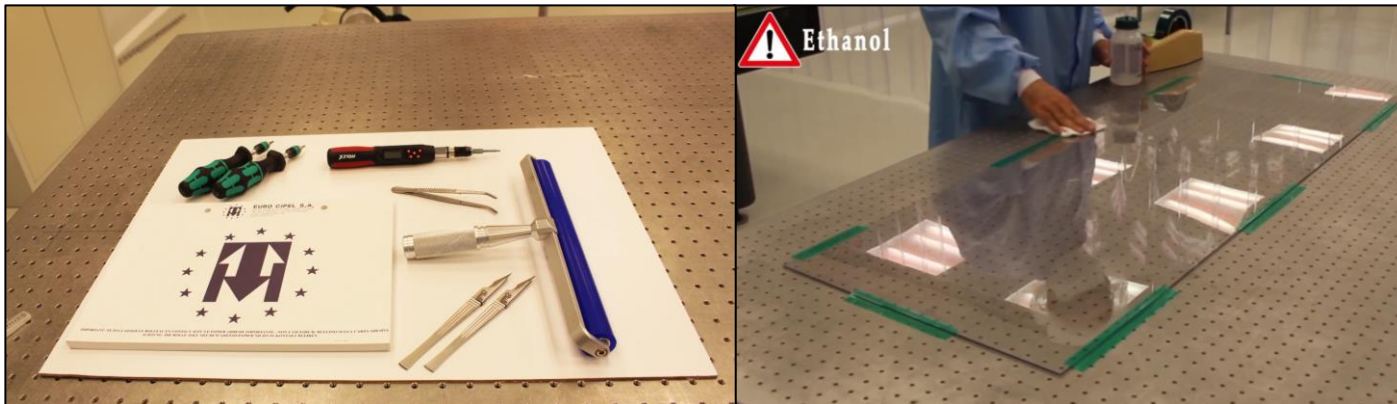

Step 2: the internal frames, responsible of holding the GEM stack, are cleaned with an anti-static roll (left) and placed on working table thanks to guiding pins (right).

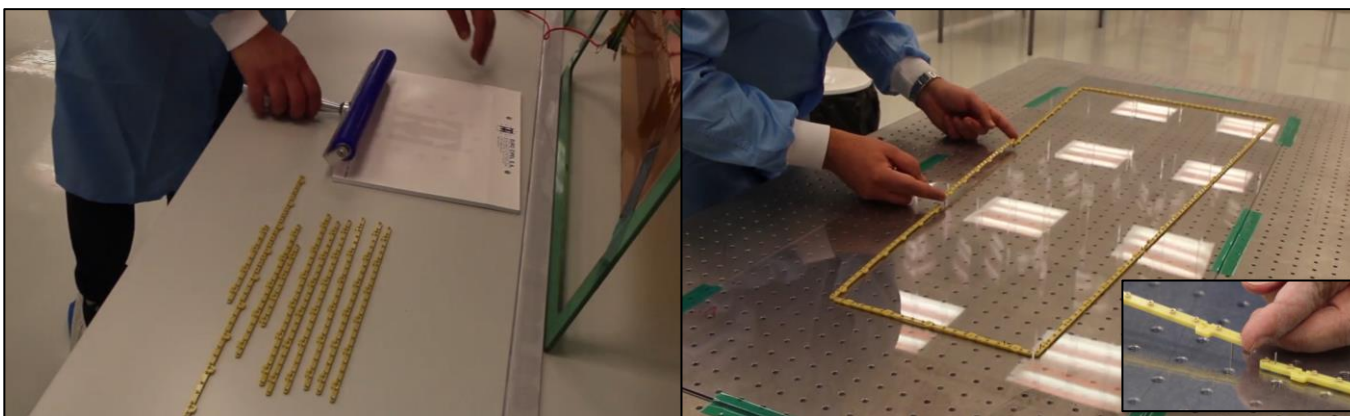

Step 3: the first GEM foil is tested at 550 V and cleaned again with the adhesive roll.

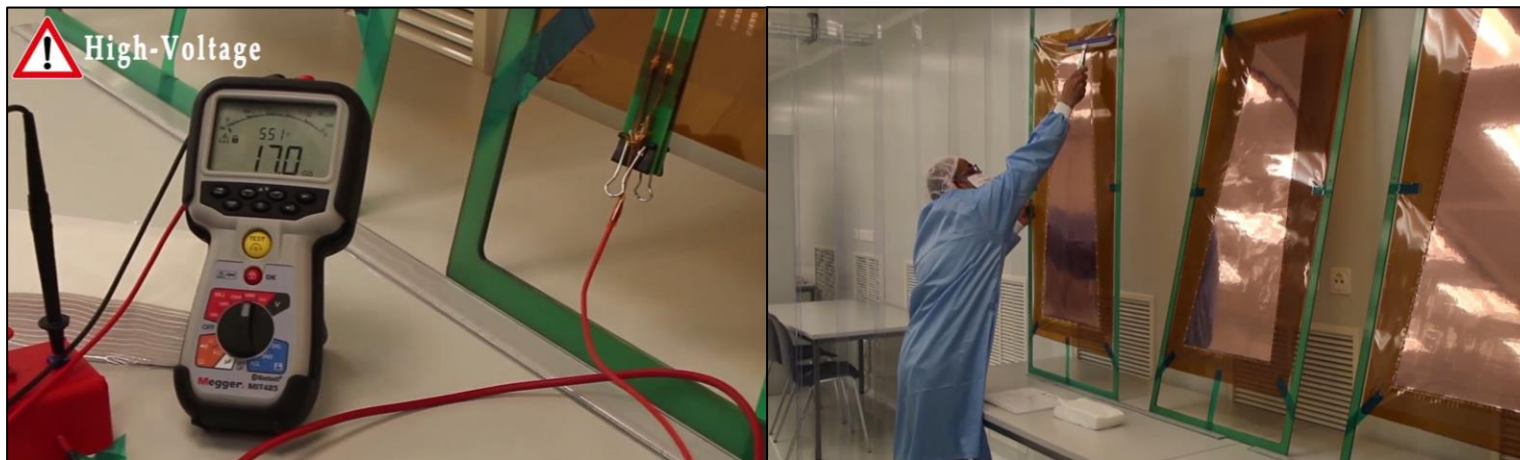

Step 4: the first GEM is placed on the first layer of internal frames (left). The foils is stretched by hand and attached to the working table to ensure the flatness and stability of the structure (right).

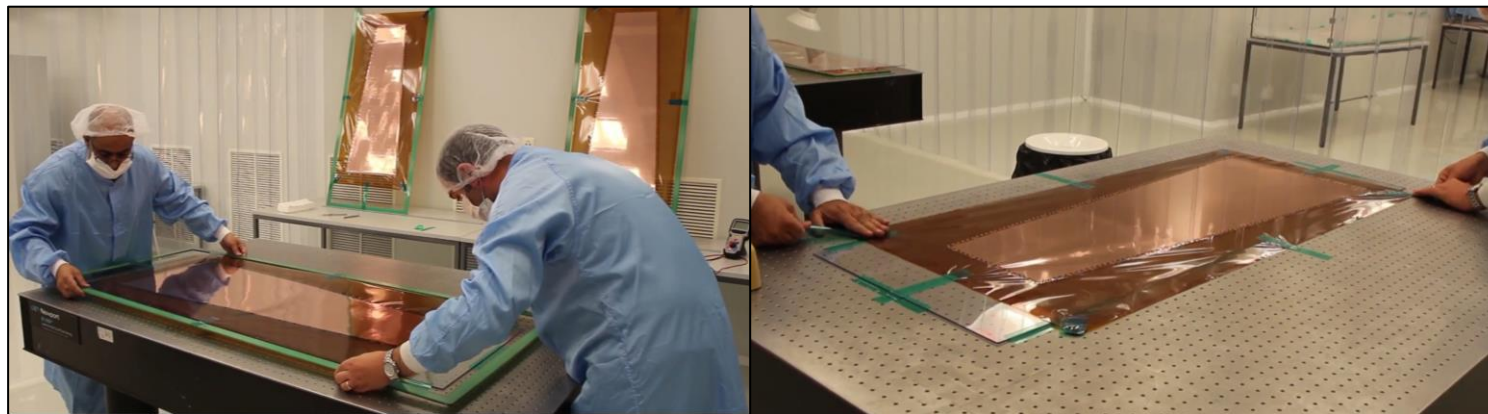

Step 5: the second layer of internal frames is placed on top of the first GEM (left). After testing and cleaning, the second GEM is added to the stack (right).

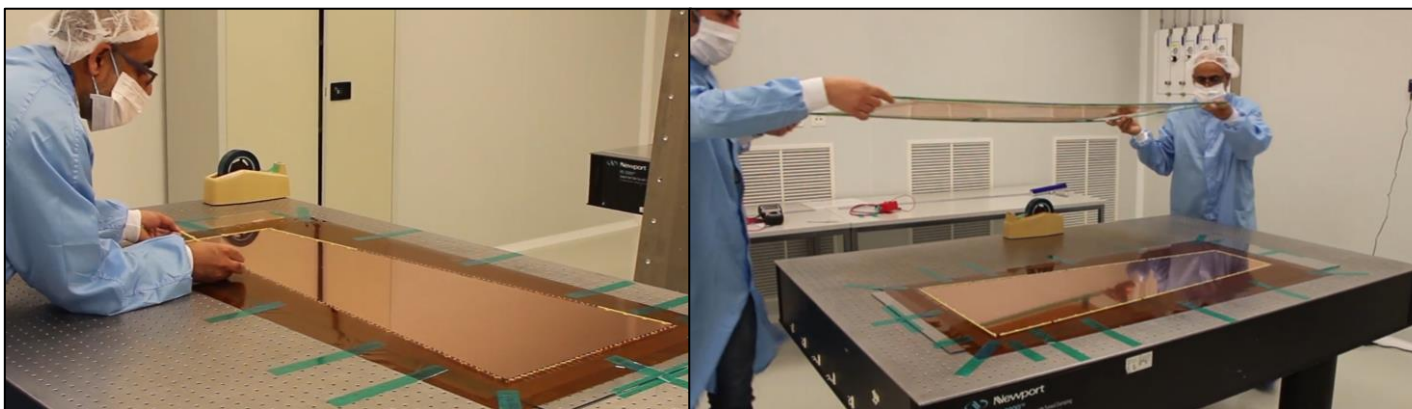

Step 6: same operation as before, the second GEM is stretched manually (left) and tested at 550 V (right).

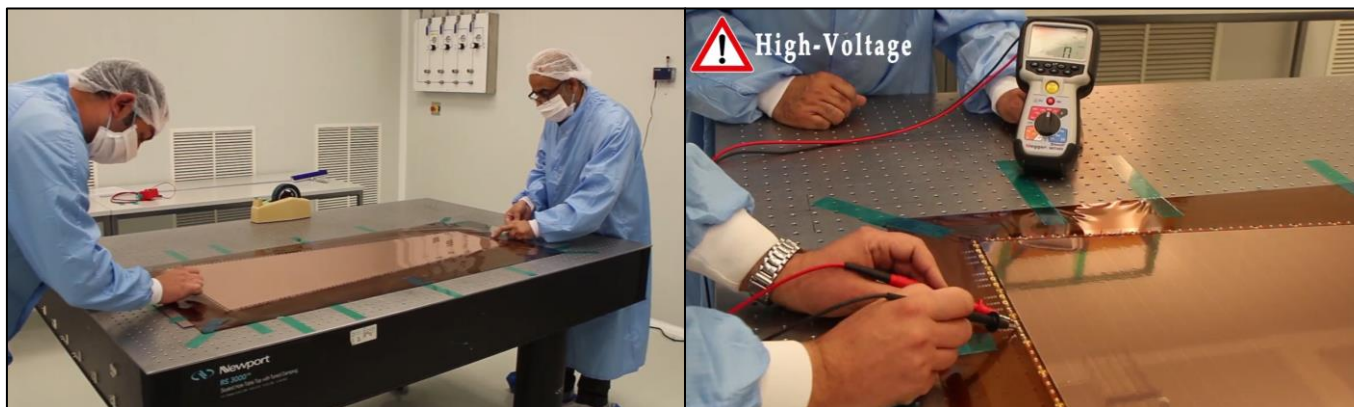

Step 7: after the third layer of internal frames is in position, metallic nuts are inserted in the dedicated housing of the frames. Then, the last GEM foils is added to the structure.

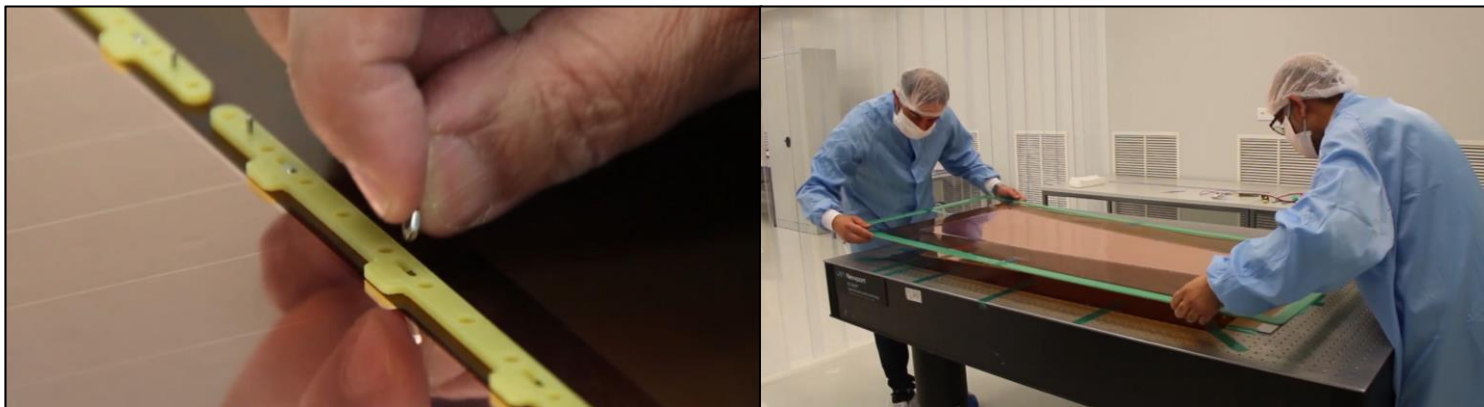

Step 8: the last layer of internal frames is added to close the stack (left), the GEM stack is protected by a PMMA cover placed fixed to the top of the internal frames.



Step 7: after the third layer of internal frames is in position, metallic nuts are inserted in the dedicated housing of the frames. Then, the last GEM foils is added to the structure.

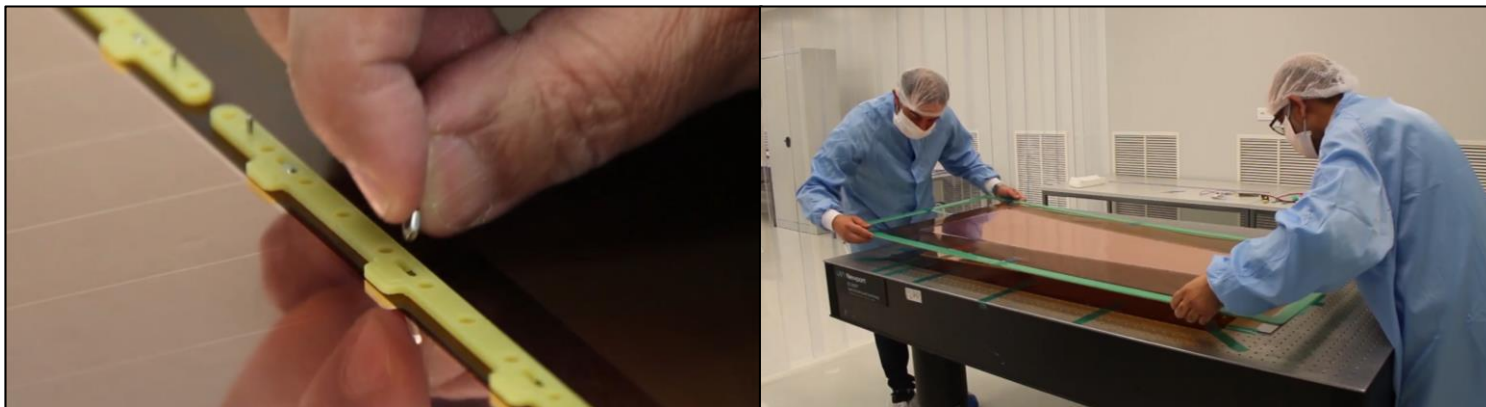

Step 8: the last layer of internal frames is added to close the stack (left), the GEM stack is protected by a PMMA cover placed fixed to the top of the internal frames.



Step 11: after being cleaned with the anti-static roll (left), the drift plane is positioned below the GEM stack (right).

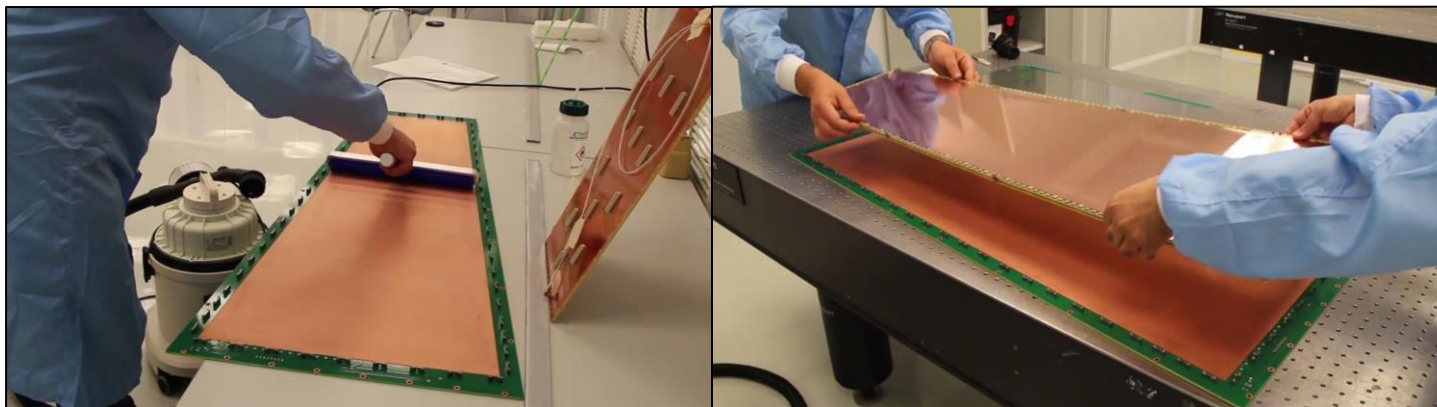

Step 12: lateral screws are inserted in the stainless steel pull-outs attached to the drift board until it reaches the embedded nuts (left). Then, torque control tools are used to stretch the foils, for a tension about $8 - 10 \text{ cN} \cdot \text{cm}$.

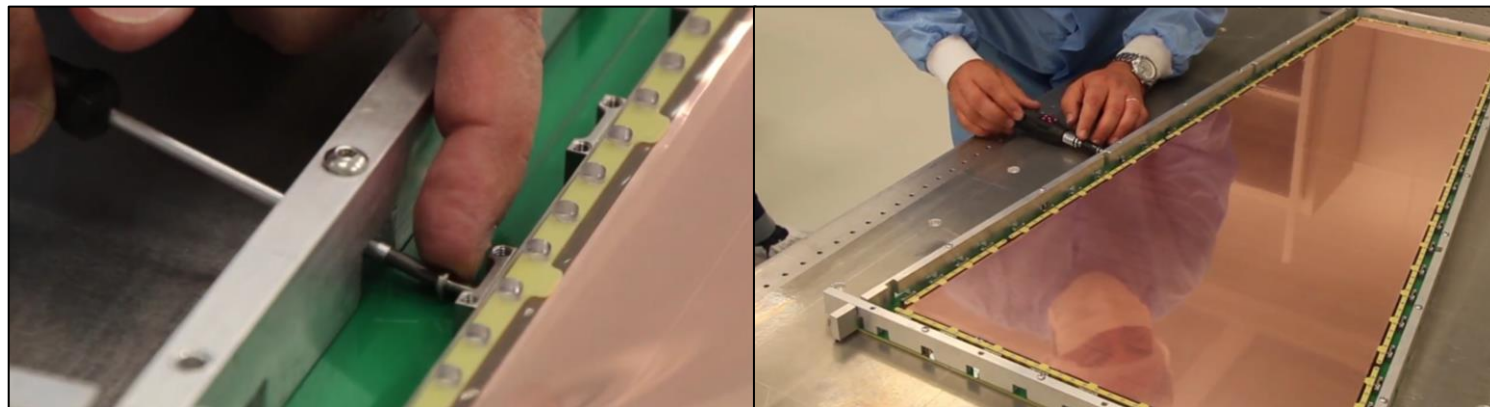

Step 13: the possible dust produced during the stretching step is removed with an anti-static roller (left) and the three GEM foils are tested once again at 550 V.

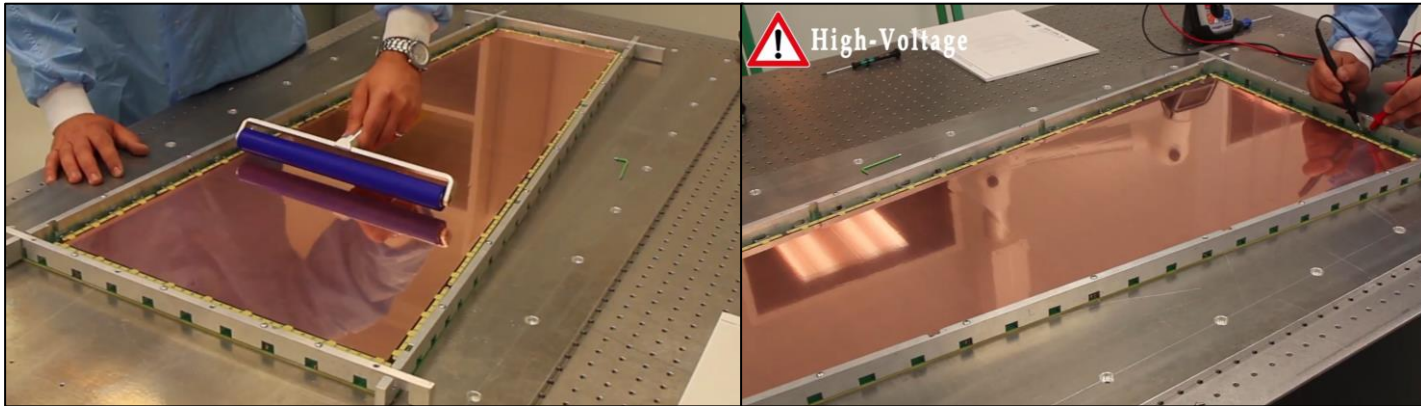

Step 14: The external frames is equipped with the O-rings (left) and it is placed around the GEM stack (right).

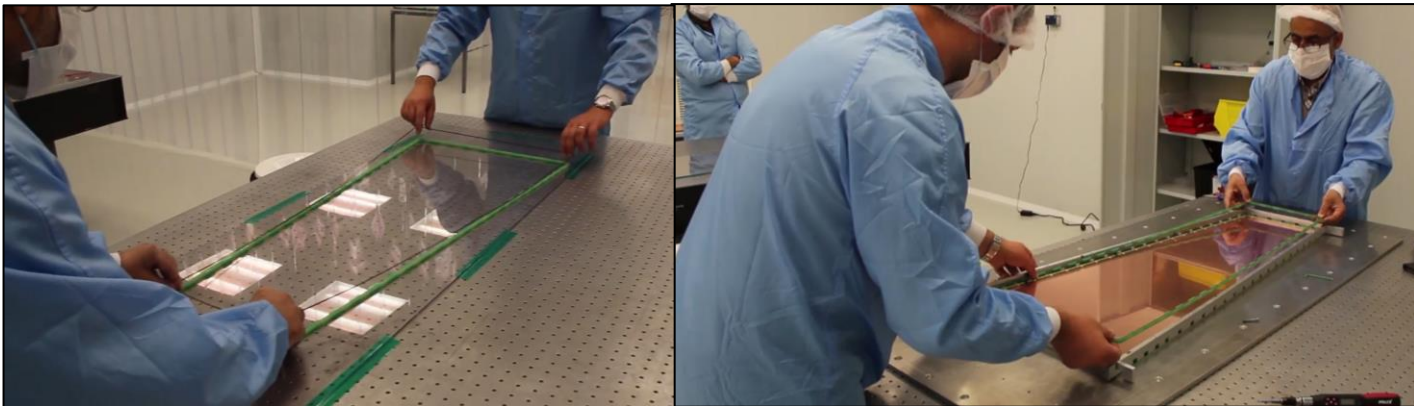

Step 15: after being cleaned (left), the readout board is placed on top of the external frame to close the chamber.



Step 16: finally, washers are inserted in the dedicated housings of the readout board before the last screws are used to attach all the elements together and close the gas volume (left). Picture of a last generation GE1/1 detector just after the assembly (right).

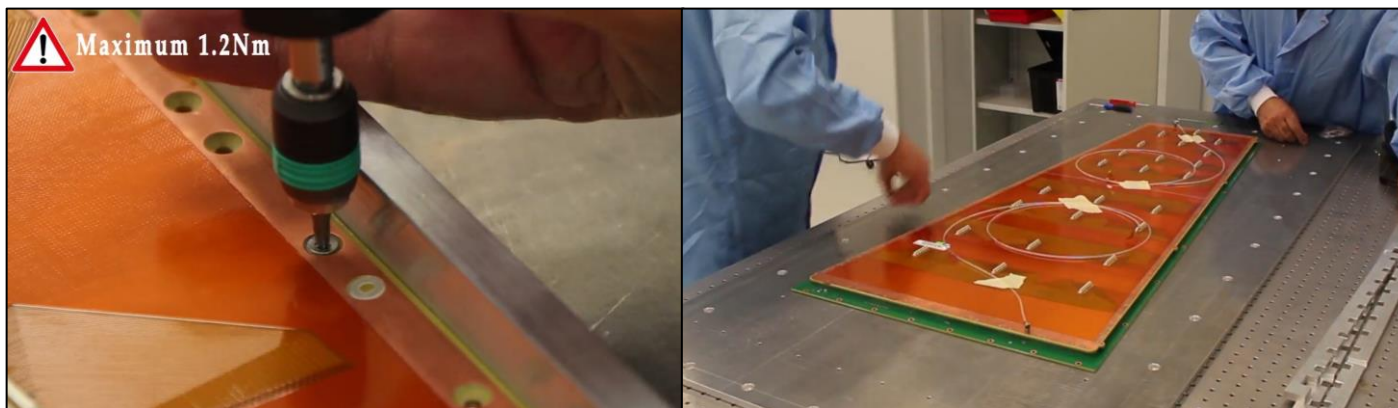

QC3 - Gas Leak Test

Identify the **Gas Leak Rate** of the detector by monitoring the drop of the internal over-pressure as a function of time and check the gas tightness

- The detector is pressurized at 25 - 30 *mbar* in pure CO_2

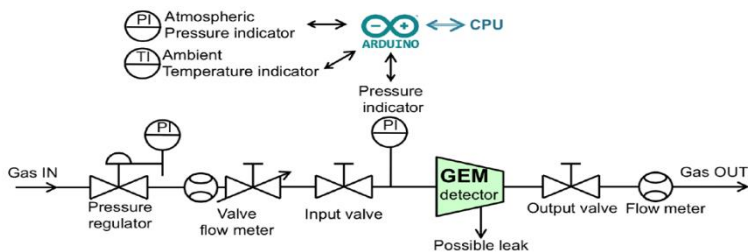

- The **pressure drop** is measured during one hour after closing the gas volume
- The experimental data are modeled by the function: $P_m = P_0 \times e^{-t/\tau}$ to extract the **gas leak time constant τ**

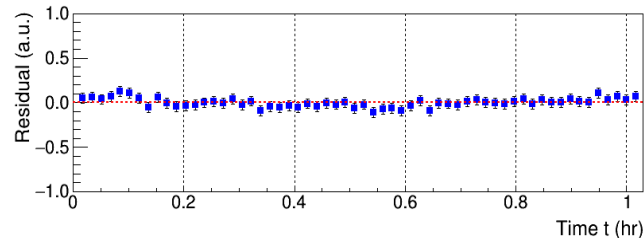
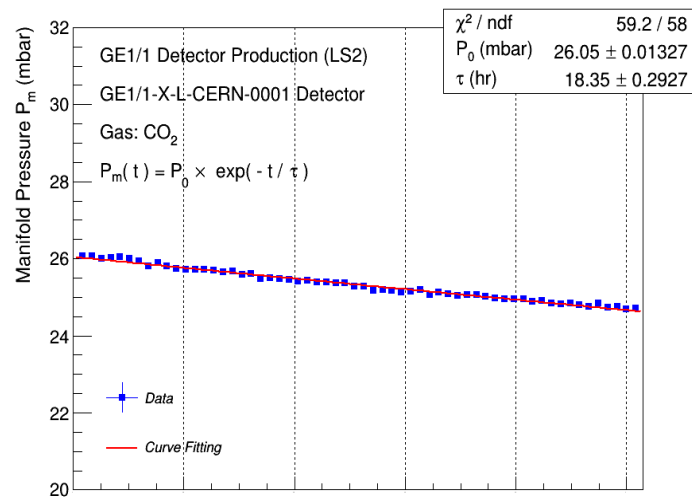

Typical *Pressure vs Time* curve obtained during the QC3 gas leak test. The parameter τ obtained by fitting is the Gas Leak Time Constant.

QC3 - Gas Leak Test

→ *Acceptance criteria*

The detector under test is validated if the pressure drop in the detector + gas system does not exceed:

$$\Delta P \leq 7 \text{ mbar/hr}$$

at initial over-pressure of 25 mbar, which corresponds to a gas leak time constant:

$$\tau \geq 3.04 \text{ hr}$$

Examples of damage assembly components identified as potential gas leak sources in the GE1/1 detectors



GAPS AT THE INTERFACE BETWEEN THE EXTERNAL FRAME AND PCBs



FAULTY WASHERS



BENDED PULLOUTS



CLOGGED GAS CONNECTORS



FAULTY SCREWS

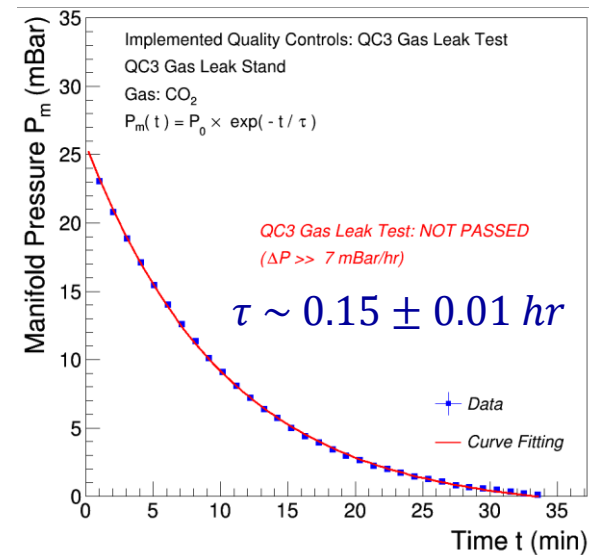
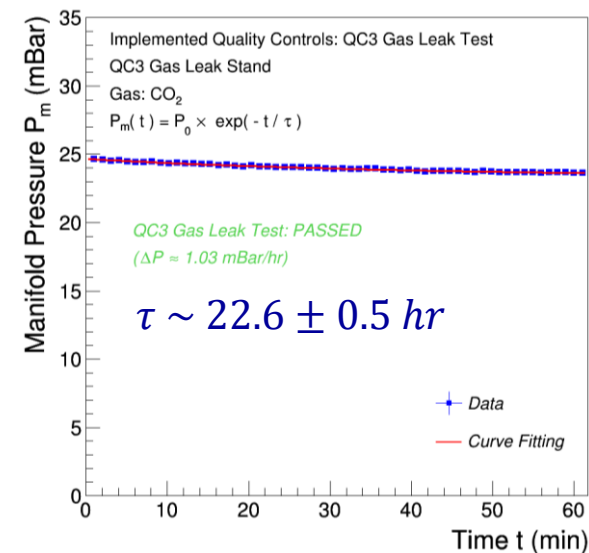

Annex C (GE1/1 Chamber QA/QC)



QC3 - Gas Leak Test

- CERN
- QC1 Material Inspection
 - QC2 GEM-foils Test

- Pressurize the detectors at 25 mbar
- Measure the pressure drop during one hour after closing the gas volume
- Fit the results to extract the time constant of the system

- Production sites
- Assembly
 - QC2 GEM-foils Test (fast)
 - QC3 Gas Leak Test**
 - QC4
 - QC5

Statistics: (*mean* ± *std.*)

Time Constant = 16.2 ± 11.8 hr

- CERN
- QC6
 - QC7
 - QC8

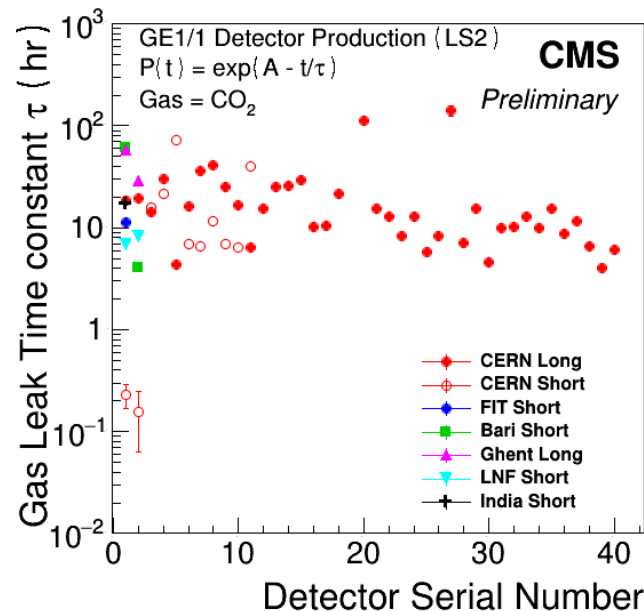
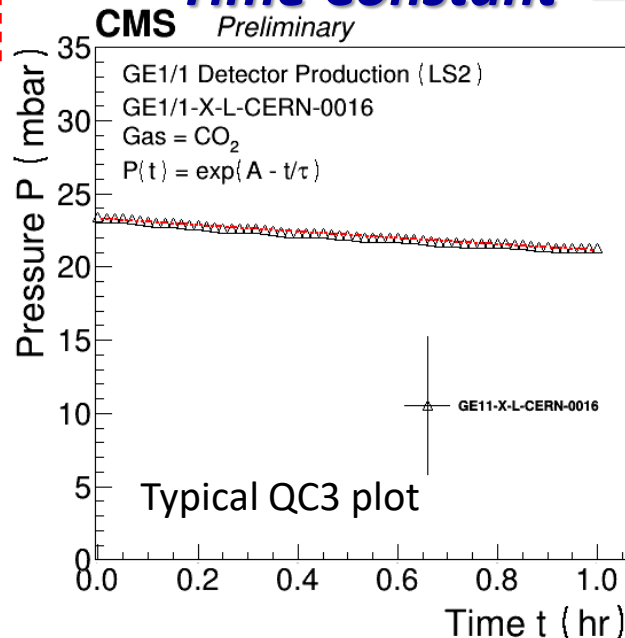

QC4 - High Voltage Test

Determine **Current vs Voltage** curve of the detector and identify possible malfunctions, defects in the HV circuit

- The detector is ramped up to 3.0 kV in step of 200 V and up to 4.9 kV in step of 100 V in pure CO₂ using a resistive HV divider
- For each step, the **current** through the HV circuit of the detector is recorded
- The experimental data are modeled by the function: $I_{mon.} = \left(\frac{1}{R_{equiv.}}\right) \times V_{mon.}$

→ **Acceptance criteria**

$$\frac{|R_{measured} - R_{expected}|}{R_{expected}} \times 100\% \leq 2\%$$

(The percentage variation of resistance reflects the goodness of the linearity of the experimental Current-Voltage curve)

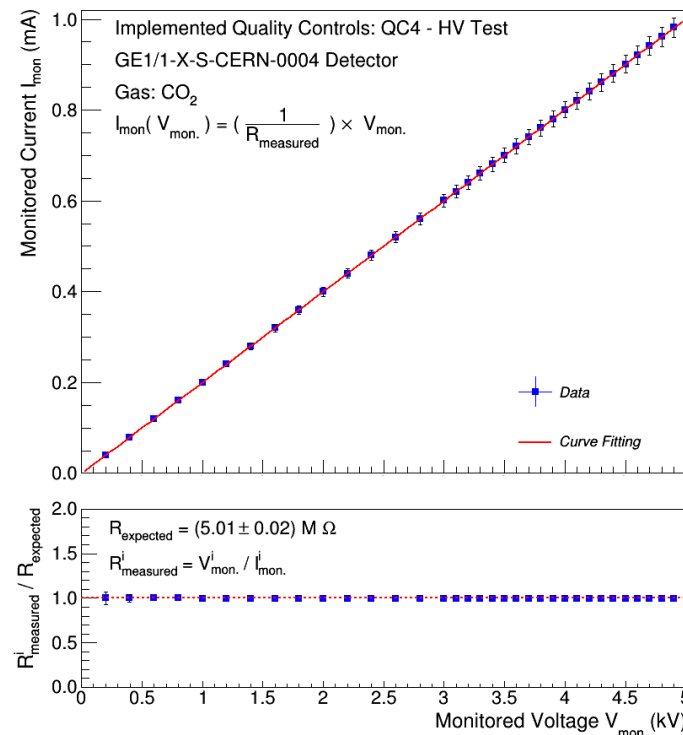

Typical *I* vs *V* curve obtained during the QC4 HV test. *I_{mon.}* represents the current flowing through the HV divider to provide power to the detector electrodes.

QC4 - High Voltage Test

Determine **Intrinsic Noise Rate** (i.e. pulses not produced by ionizing particle) over the entire detector surface

- The detector is ramped up to 3.0 kV in step of 200 V and up to 4.9 kV in step of 100 V in pure CO₂ using a resistive HV divider
- For each step, the intrinsic noise rate R_{noise} of the detector is recorded from the bottom of the third GEM-foil

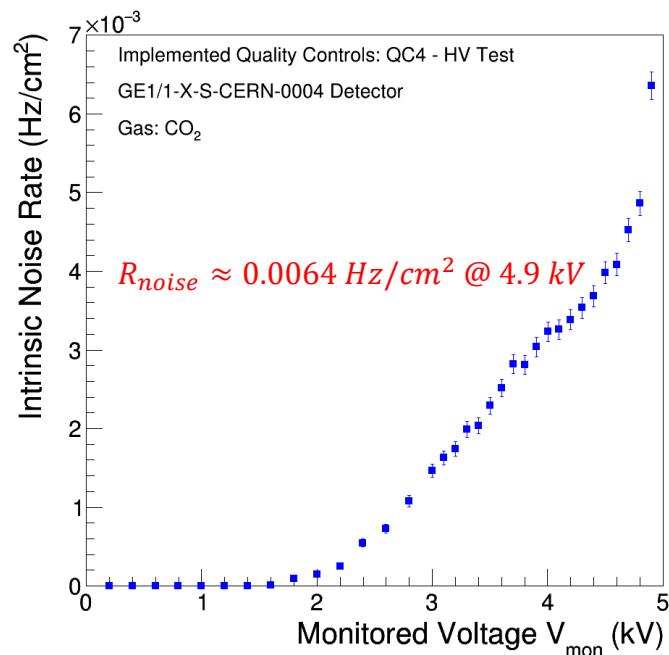
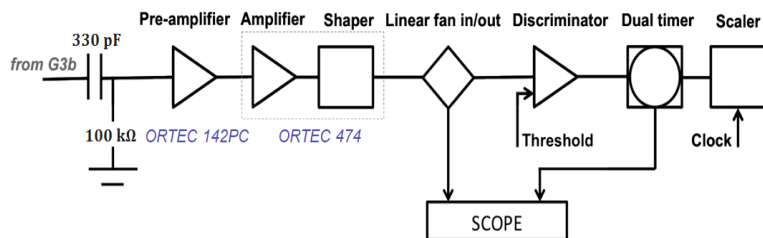

→ **Acceptance criteria**

$$R_{noise} \leq 0.02 \text{ Hz/cm}^2 \text{ (at 4.9 kV)}$$

Typical *Intrinsic Noise Rate* as a function of the applied voltage obtained during the QC4 HV test:
 $R_{noise} \approx 6.4 \times 10^{-3} \text{ Hz/cm}^2 \text{ at 4.9 kV.}$

QC5 - Gas Gain Measurement

A 2-steps procedure to measure the Effective Gas Gain

STEP 1

Effective Gas Gain Measurement

- First operation in Ar/CO₂ (70/30) at high particle flux
- Get the **effective gas gain versus HV in one readout sector**

STEP 2

Response Uniformity Measurement

- Get **“internal” gas gain variations map**
- Get **average gas gain and std. deviation after compiling with eff. gas gain meas.**

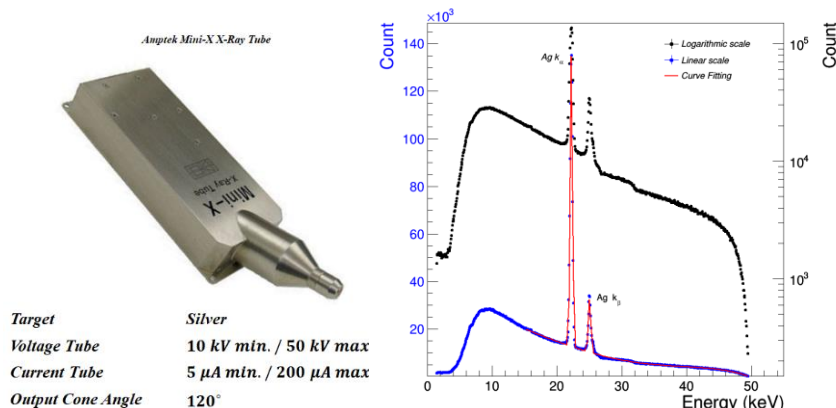

Both tests performed inside a copper box using an X-ray generator (~ 22 keV X – rays)



QC5 - Effective Gas Gain Meas.

Measure the **Effective Gas Gain** as a function of the voltage applied on the resistive high voltage divider

- Effective gas gain of GE1/1 detector is measured in a single readout sector ($\eta = 4, \phi = 2$)
- The Effective gas gain is defined as:

$$G_{\text{eff}} = \frac{I_{\text{RO}}}{(n_p \times q_e \times R_s)}$$

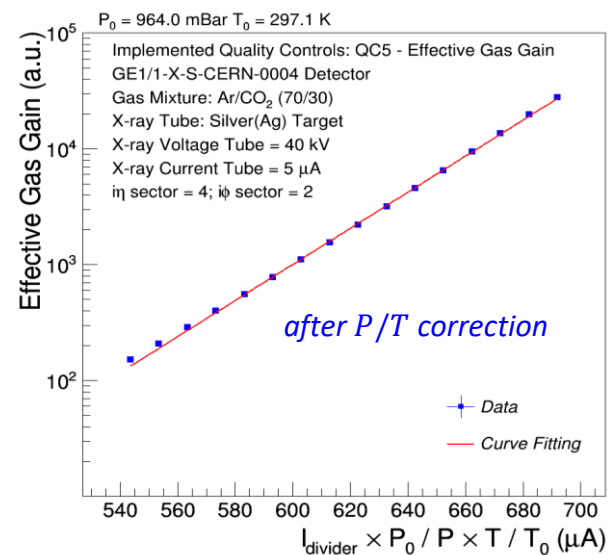
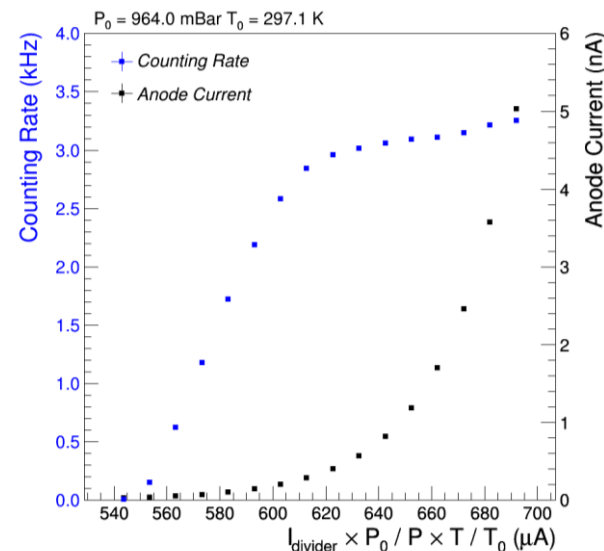
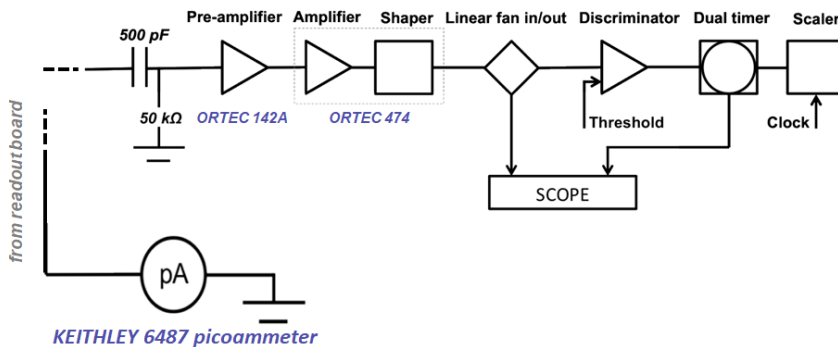
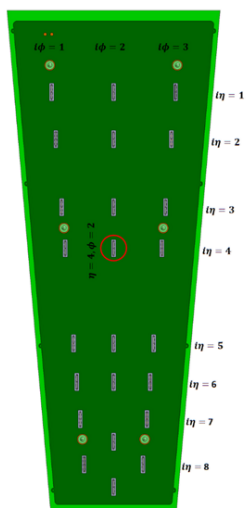

QC5 - Response Uniformity Meas.

Measure the internal gas gain variations maps for each detector

- Detector fully irradiated with X-rays
- RO based on analog electronics (APV25)
- Measure the copper fluorescence for every readout channels
- Compare ionization peak position (2D map)
- The uniformity map is used to calculate the average effective gas gain and the standard deviation for each detector

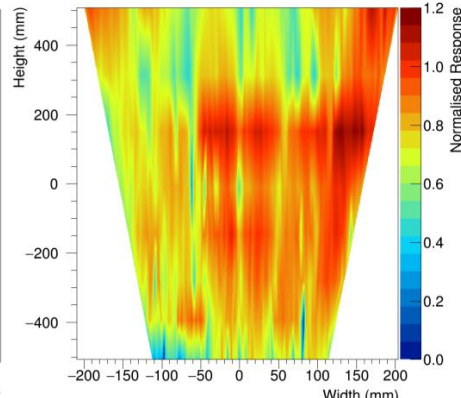
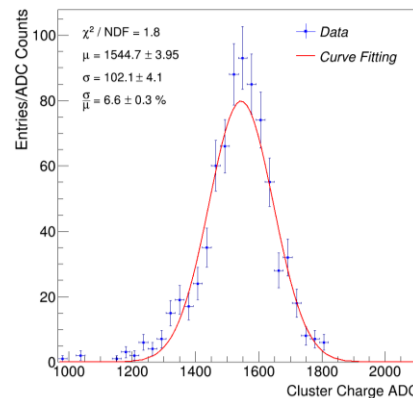
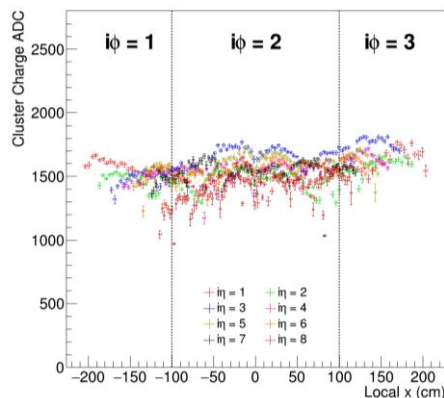
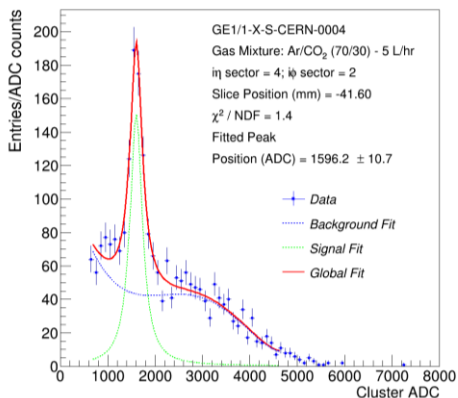
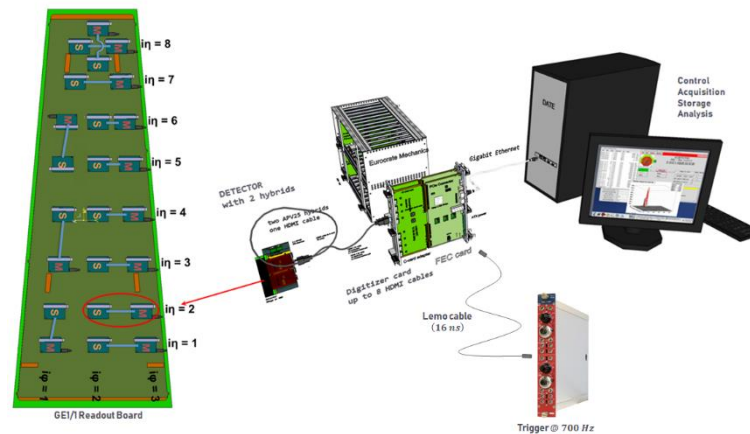

Annex C (GE1/1 Chamber QA/QC)

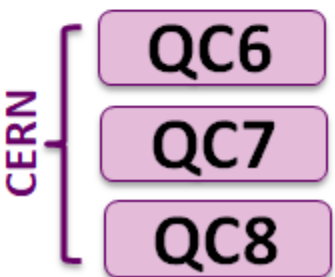
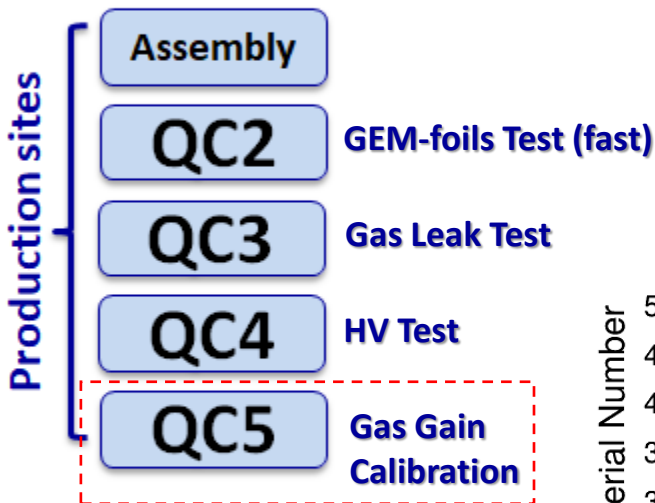

QC5 – Step 1 Effective Gain Test

→ Measure the absolute gas gain in one readout sector

Statistics: (mean ± std.)

Long → $G_{eff} = 5786.9 \pm 2108.8$ (36.4%)

Short → $G_{eff} = 7980.0 \pm 2893.3$ (36.2%)

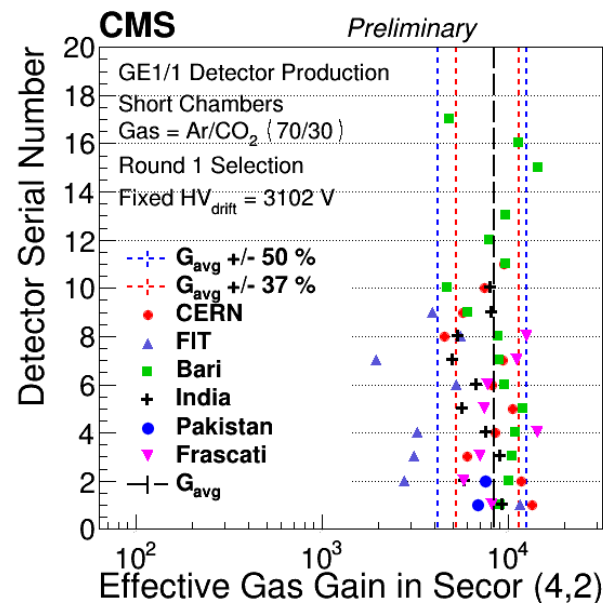
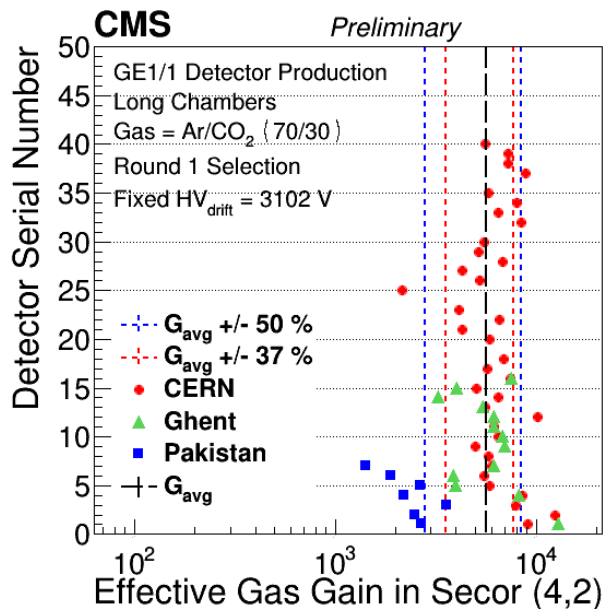

- **Measuring the discharge probability:**
 - Tests in laboratory (alpha particles) with both small and large detectors
 - Tests in neutron facilities with CMS-like particle background
- **Test results:**
 - Determined lower and upper limits for discharge probability
 - Estimate total number of discharges per cm^2 in the hottest region
 - No temporary or permanent degradation of the detector performance could be measured after alpha irradiation, nor in neutron environment

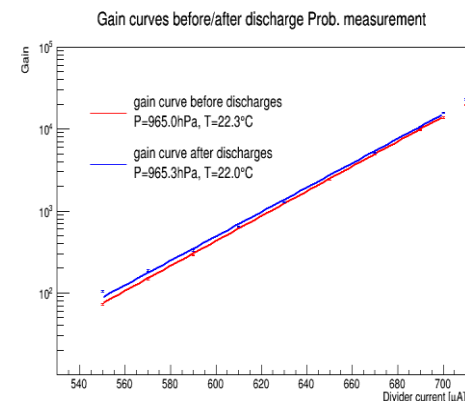
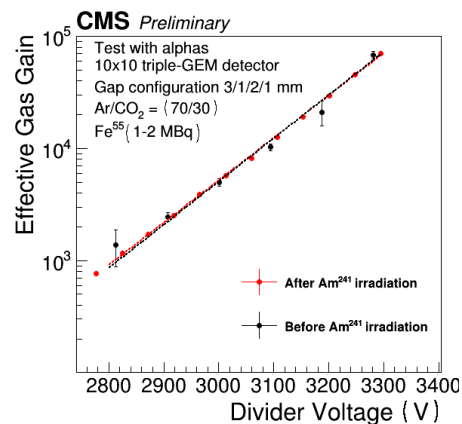
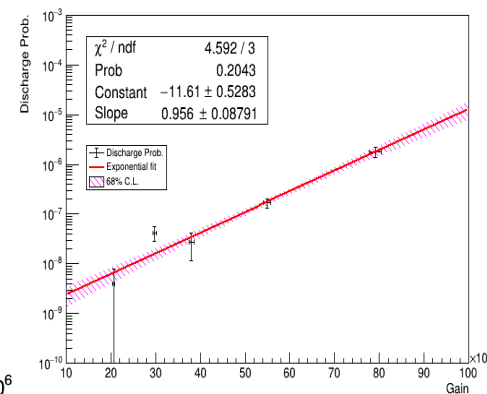
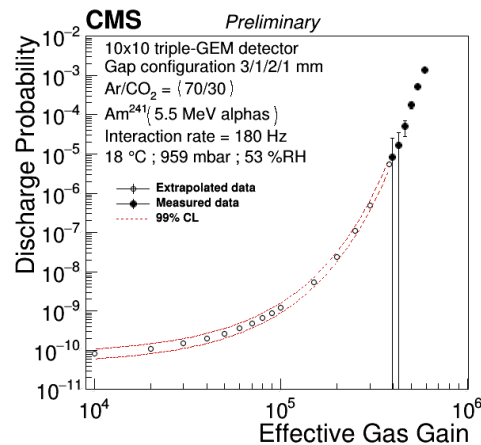

Annex D (GEM Discharges Studies)

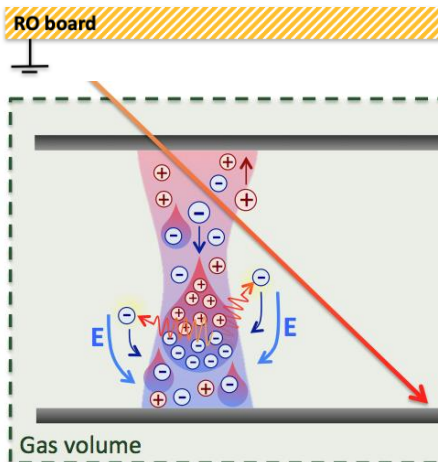
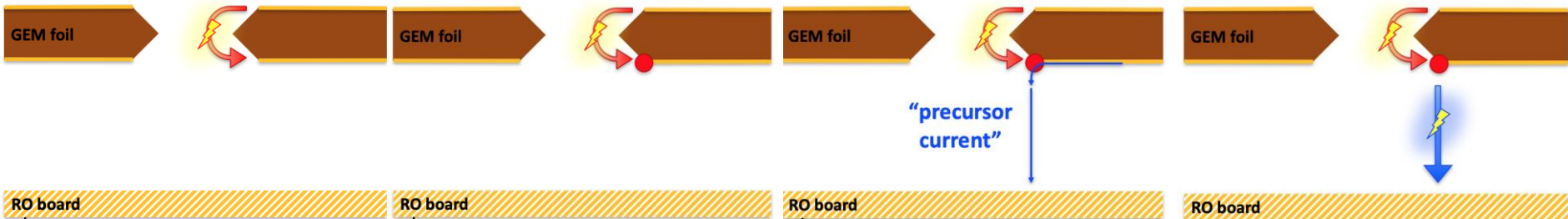

Typical development of avalanche into a streamer

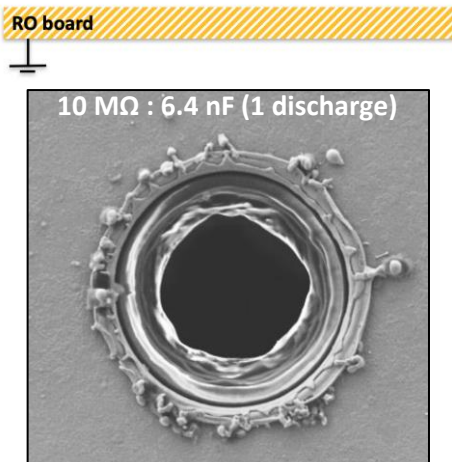

SEM picture of a GEM hole (bottom) after one discharge with an energy of 2.0 mJ

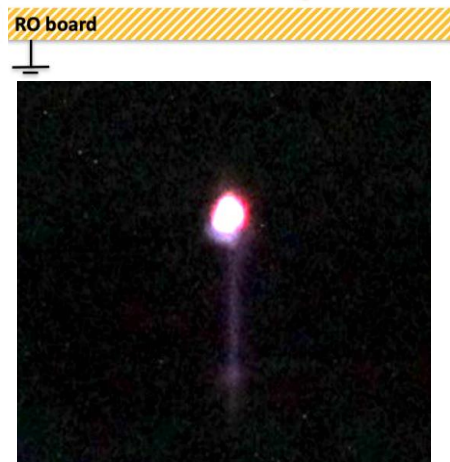

A. Utrobičić et al. (University of Zagreb), MPGD Stability Workshop June 2018

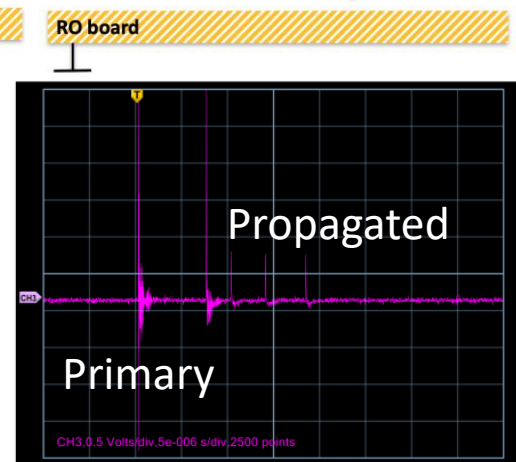

Typical EM interferences caused by propagating discharges in GEM detectors

- Step 1:** Primary discharged caused by the increase of the space charge density in the avalanche

- Step 2:** Creation of a hot spot on the copper near the hole rim $>2500\text{ }^{\circ}\text{C}$

- Step 3:** Thermionic emission of electrons in the gas, enhanced by local electric field (Schottky effect)

- Step 4:** Development of the precursor current into a streamer causing a second discharge

- **Specific study on single GEM hole systems:**
 - Special GEM foil design with single hole to control the conditions of discharges and isolate the elements that play a role
- **Test results:**
 - Measurements reveal high resistance to discharges, even at high energy ($>10^3$)
 - Slight increase of the hole diameter after 10-20 discharges
 - No effect on detector gain since sharing of amplification over several layers and several holes

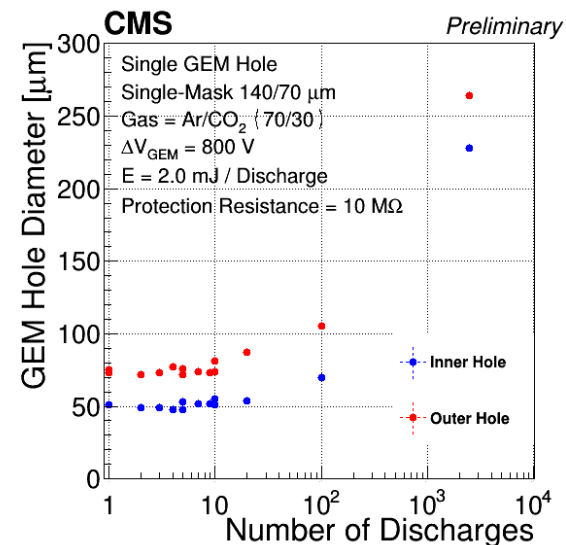
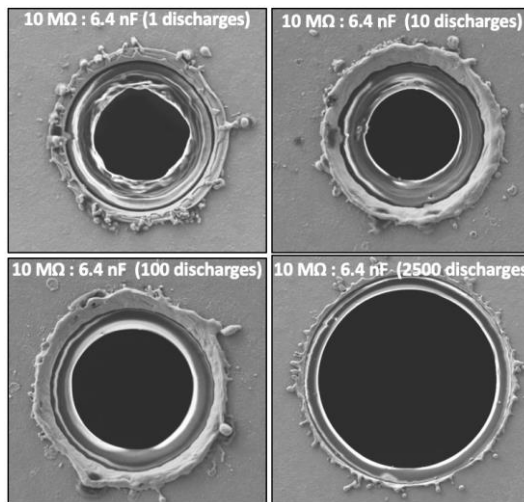
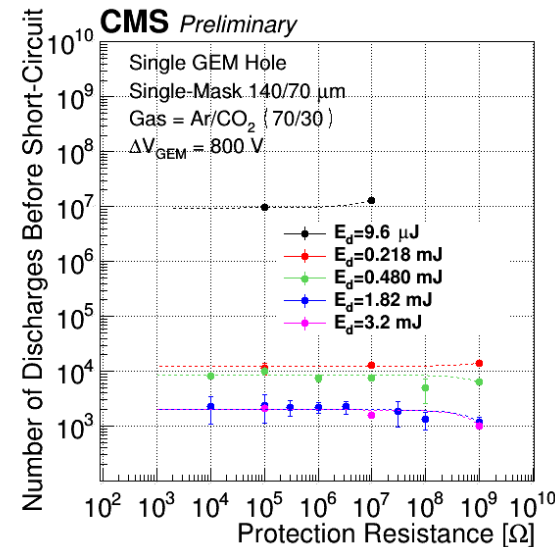
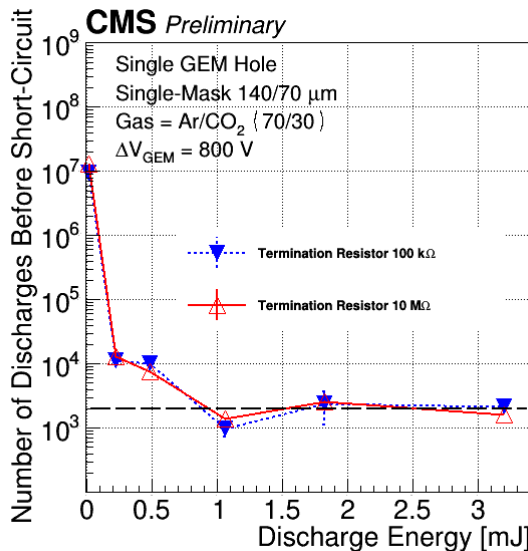

GE1/1 Discharges

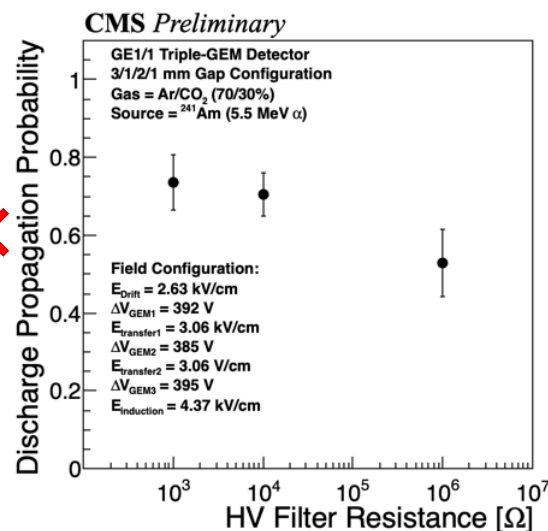
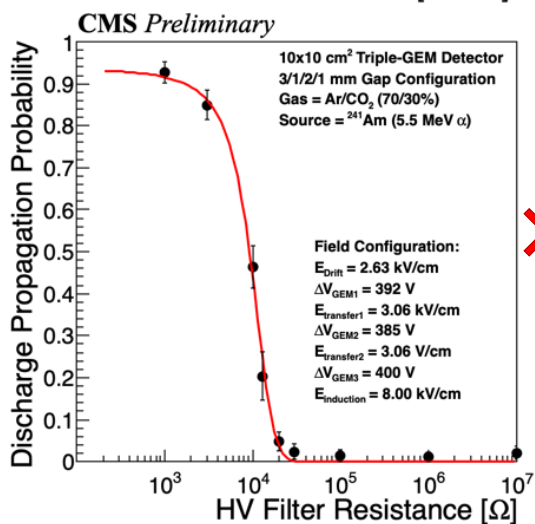
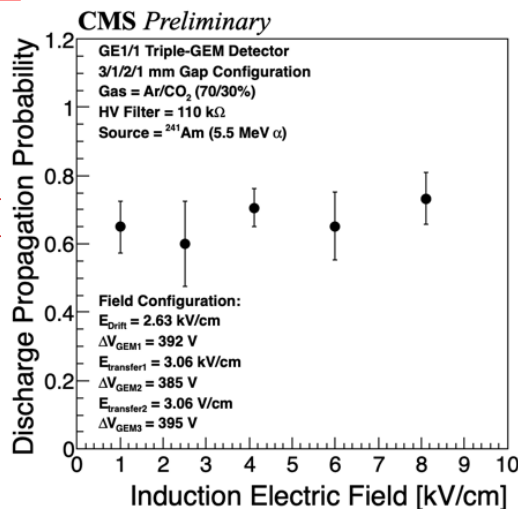
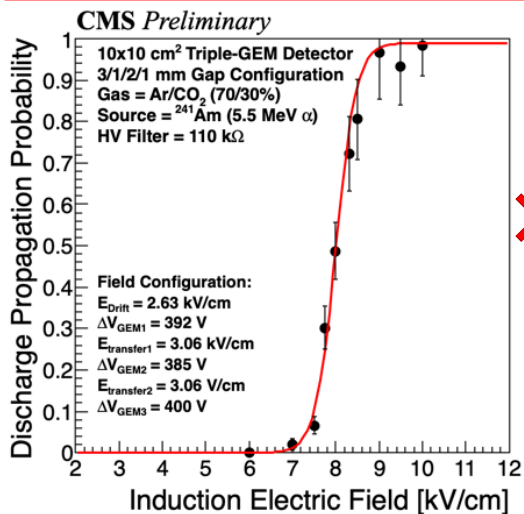

Tests with small 10x10 detectors:

- Influence of the induction field and filter resistor

Tests with large detectors:

- No dependency on the induction field
- No effect from the filter resistor
- Clear inconsistency between small and large chambers
- Clear increase of the propagation probability with the induction capacitance → i.e. sufficient amount of energy on the foil to feed the precursor current and trigger discharge propagation

GE1/1 Discharges

- Further studies to understand the differences between small and large chambers:
 - No dependency with the GEM foil capacitance → no influence of the primary discharge energy
 - Clear increase of the propagation probability with the induction capacitance → i.e. sufficient amount of energy on the foil to feed the precursor current and trigger discharge propagation
 - All measurements indicate that the discharge propagation is more likely to happen in large foils due to the availability of energy directly stored in the foil

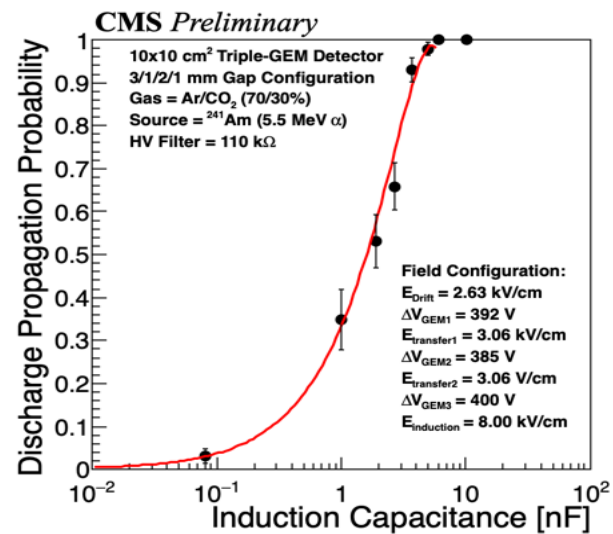
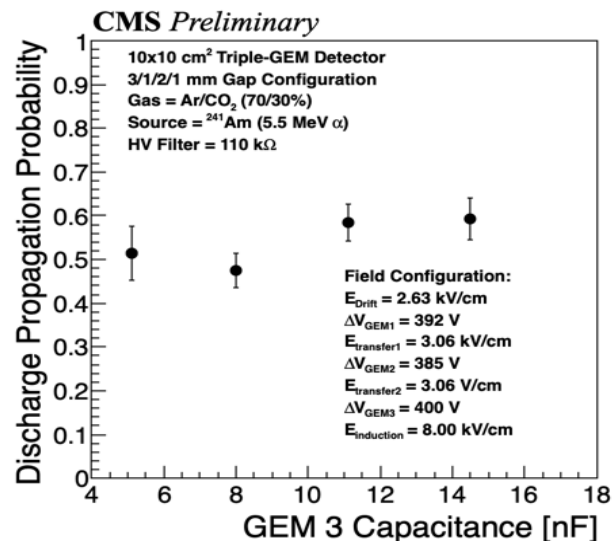

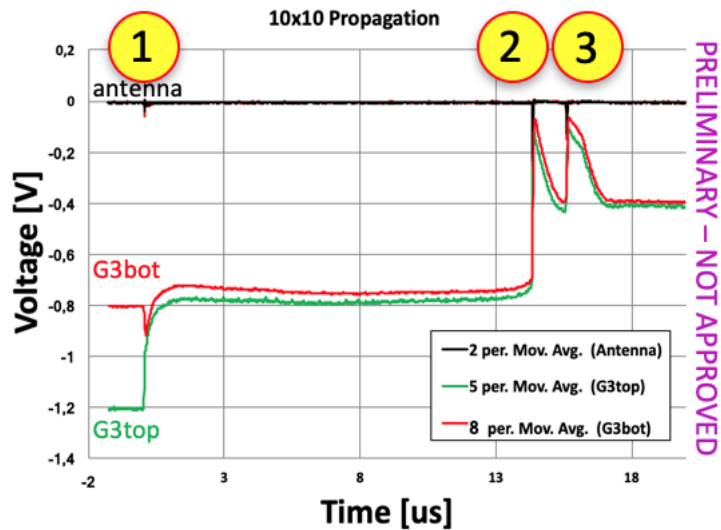

- ① Primary discharge in GEM3
- ② Propagation from GEM3 to Readout
- ③ Re-ignition of the propagation

Propagation process in small detectors is simple and localized

Large Detector

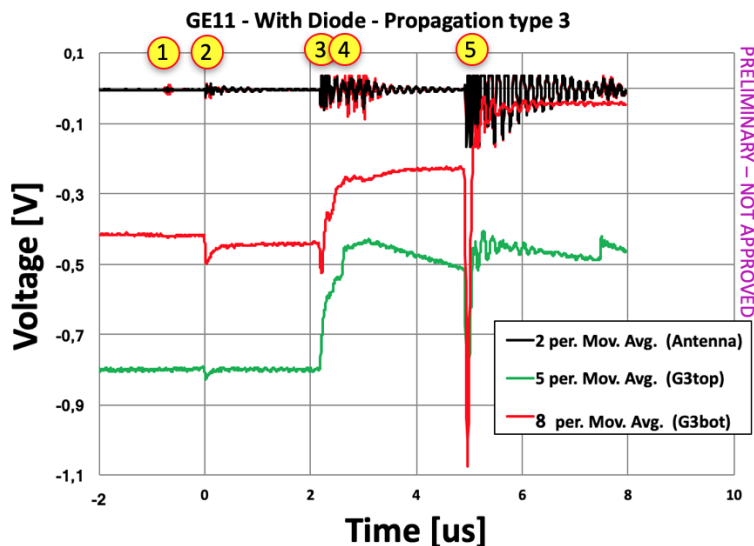

- ① Primary discharge in GEM3
- ② Propagation backward in GEM2
- ③ Propagation forward in GEM3
- ④ Propagation from GEM3 to Readout
- ⑤ Re-ignition of the propagation

Propagation process in large detectors is **more complex** (discharges "travel" backward and forward, accumulating more energy)

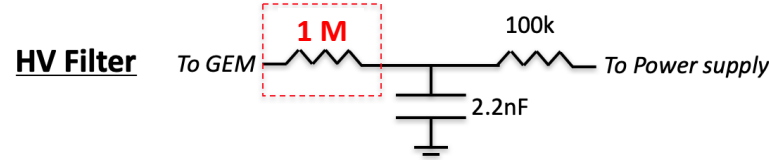
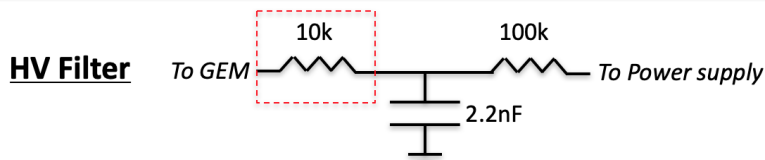
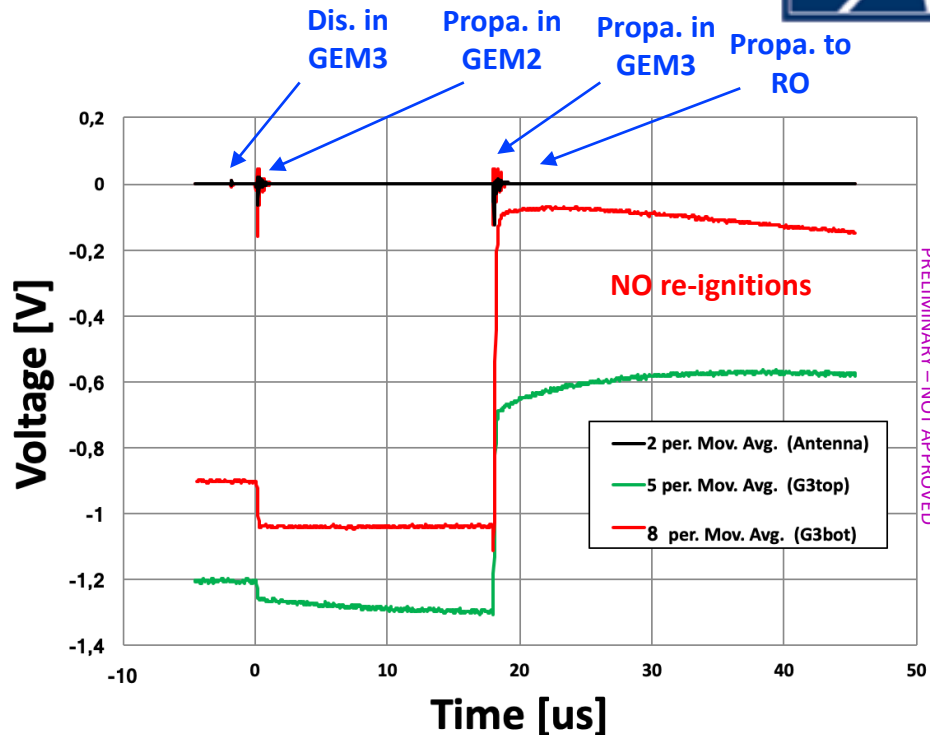
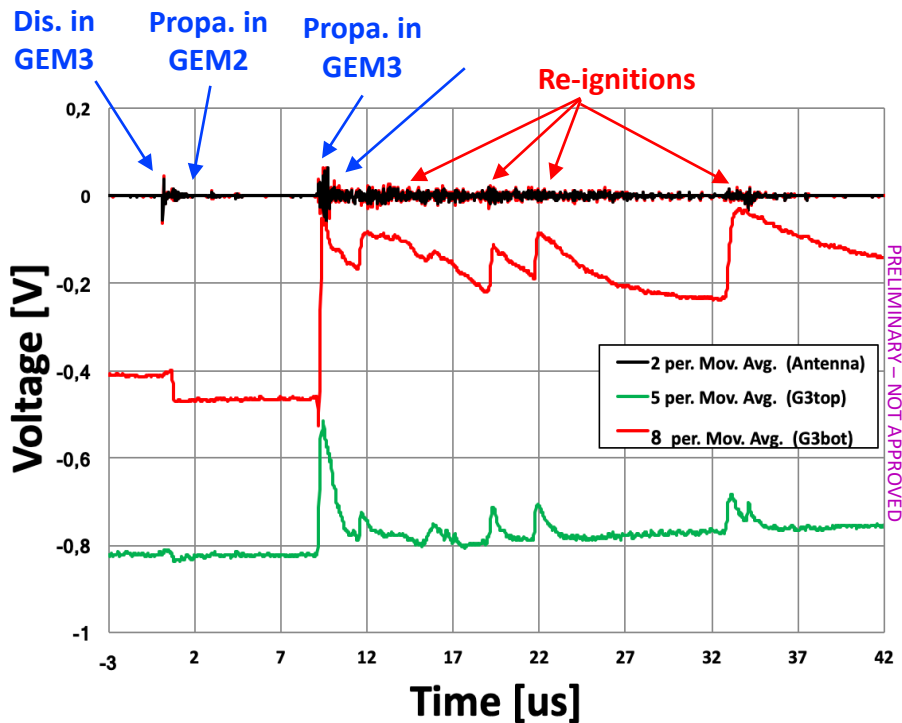

- **In-depth investigations with large detectors:**
 - Further studies indicates that the damage probability in large detectors is mainly due to propagation re-ignitions
 - Re-ignitions are fed by the energy stored in the filter capacitance → can be mitigated by tuning the filter capacitance → can reduce by a factor 10 the damage probability

Annex D (GEM Discharges Studies)

GE2/1 Discharges

Introducing the final configuration based on the “mixed” design:

- GEM1 and GEM2 are **double-segmented** to prevent the **discharge propagation**
- GEM3 is **single-segmented** to suppress the **crosstalk**
- The foil is actually double-segmented but the bottom segments are merged together using **0 Ω jumpers**

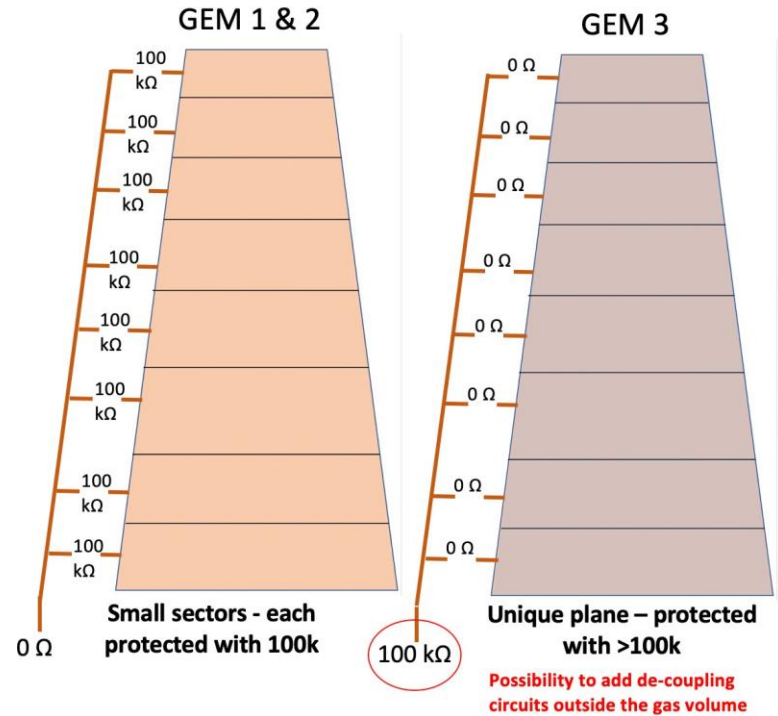
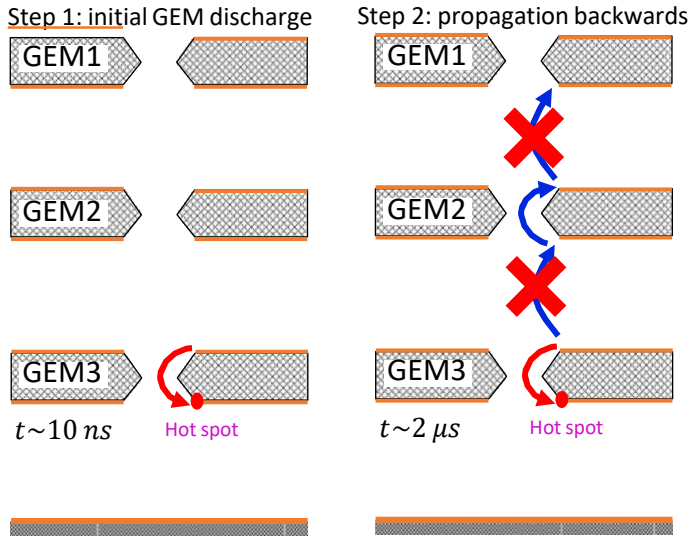

The propagation at low induction field can be stopped in the **transfer gaps** thanks to the double segmentation on the first GEMs
 → Propagation stopped before it can reach the RO

Merging the HV segments on the bottom of GEM3 allows to reproduce the single-segmented behavior while having the **same layout** for all the GEMs

ME0 Discharges

HIP with $E_{\text{deposited}} > 30\text{keV}$

$P_d = 1.24 \times 10^{-9} \pm 1.16 \times 10^{-9}$
(average of the two sets of tests we performed)
Measured with $E_{\text{deposited}} \sim 350\text{keV}$

Assuming a LHC duty cycle = 0.33

Factor based on the GEM foil design

Factor based on the RO circuitry

Factor based on the electronics protection circuit

Factor based on the optimization of the internal electric fields

System	Max HIP rate $R_{\text{HIP}}^{\text{max}}$	Disch. probability P_d	Max discharge rate R_d^{max}	Number of disch. per year	Transfer propagation probability	Induction propagation probability	Damage probability	Improvement factor (E_field optimization)	Number of damaged RO channels per 10 year	Fraction of damaged RO channels per 10 year
(Unit)	Hz/sector	-	Hz/sector	y^{-1} /sector	-	-	-	-	$(10\text{y})^{-1}$	$(10\text{y})^{-1}(\%)$
Slice test*	3.15×10^3	1.24×10^{-9}	3.90×10^{-6}	39	0.5	1	0.95	1	185 per VFAT(128 ch)	100
GE11	3.15×10^3	1.24×10^{-9}	3.90×10^{-6}	39	0.5	1	0.03	1	6 per VFAT	4.79
GE21	1.92×10^3	1.24×10^{-9}	2.38×10^{-6}	24	$< 3 \times 10^{-4}$	$< 10^{-3}$	0.03	1	7×10^{-7} per VFAT	~ 0
ME0	2.36×10^5	1.24×10^{-9}	2.93×10^{-4}	2927	$< 3 \times 10^{-4}$	$< 10^{-3}$	0.03	1	9×10^{-5} per VFAT	~ 0

* Obsolete design – for comparison purpose

Improved by the double-segmentation on GEM1 and GEM2

Improved by the decoupling circuit on the plugin cards

Improved by VFAT protection resistor and the new HV filter config.

Studies are on-going: the improvement is not yet quantified

ME0 Discharges

What is the impact of the new rate capability mitigation on the discharge behavior ?

**GE2/1 Baseline
(validated)**

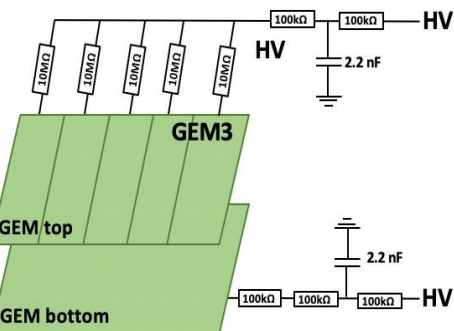
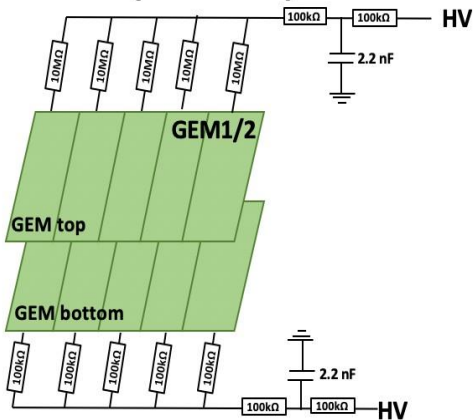

29 sectors
 $A \approx 100 \text{cm}^2$



40 sectors
 $A \approx 75 \text{cm}^2$

- Reduced area = reduced gap capacitance
- Expected reduction of the discharge propagation probability

10MΩ top protection



2MΩ top protection

- Reduced protection resistance
- Expected no impact on the discharge propagation probability (as long as $R > 30 \text{k}\Omega$)

100kΩ + 100kΩ
Filter resistors



100kΩ Filter resistors

ME0 Baseline

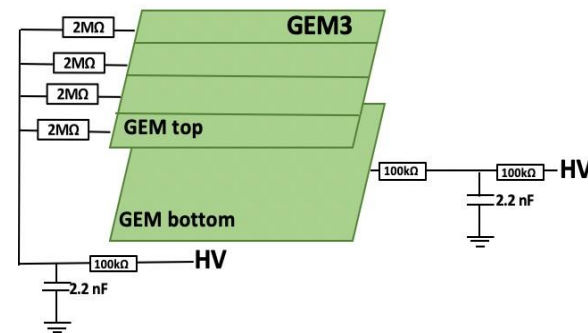
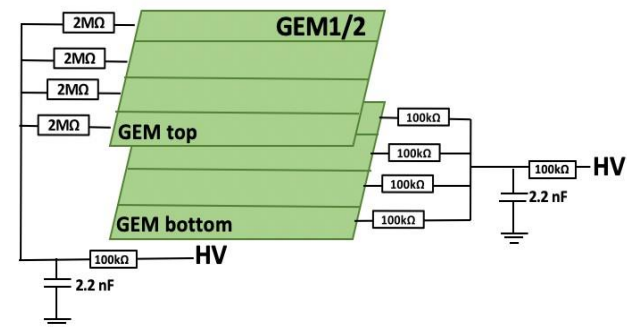

Aging of Gaseous Detectors:

How to measure longevity of gaseous detectors?

- Measure various properties of the detector at different accumulated doses
- Monitor gas gain fluctuations during the irradiation

Requirements:

- Accelerate aging with strong radiation
- **High acceleration factors reduce polymer production rate (so aging effects)**
- **Recommendations:**
 - *Acceleration factor $\ll 100 \times$ real operation (realistic conditions)*
 - *Accumulate expected dose with safety factor*
- **Monitor the environmental parameters:**
 - *Temperature*
 - *Pressure*
 - *Gas purity / gas flow rate*
- **High Purity Systems:**
 - *Aging mostly enhanced by pollution in the gas mixture*

GEM @ Gamma Irradiation Facility (GIF++)

How to reproduce the aging effects ?

- The facility consists of an intense **14 TBq** (in 2015) ^{137}Cs source emitting **662 keV photons** and lower energetic scattered photons
- The GIF++ photons have an energy fairly representative of the energy of LHC/HL-LHC photons seen by the muon detectors
- **CMS GE1/1 triple-GEM detector 4th generation** (representative of the detectors that will be installed in the CMS Muon end-caps)
- **Effective Gas Gain: 2×10^4**
- **Gas Mixture: Ar/CO₂ (70/30)** - Gas Flow Rate: **5.0 L/h**

Irradiated chamber @ GIF++ during the aging studies 2015/2016: $\sim 55 \text{ mC/cm}^2$ collected in about 6 months of continuous tests.

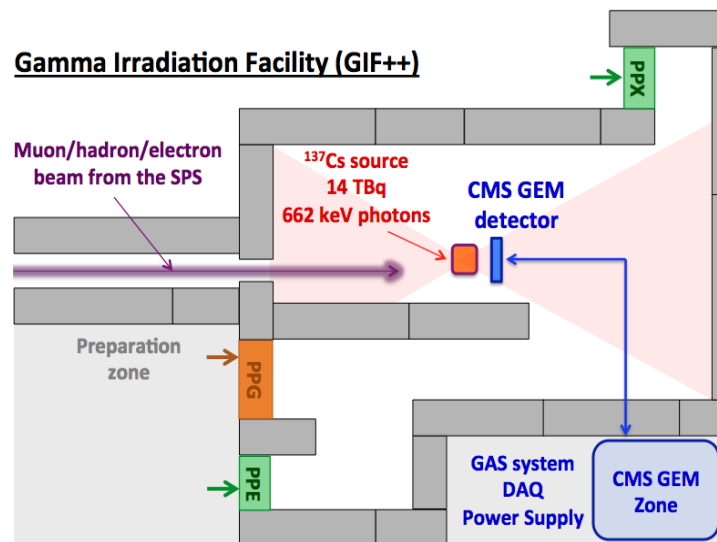
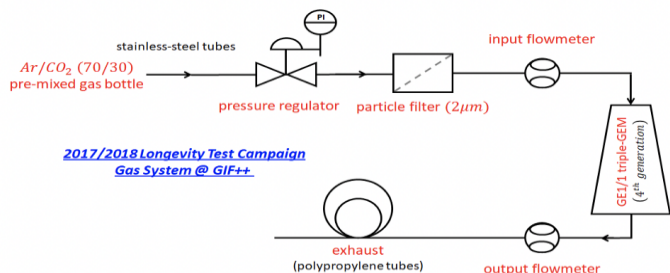

The GE1/1 detector under test is placed at $\sim 1\text{m}$ from the source point (D_1 position):

- **upper half** of the detector is operating under a particle flux just below 10^8 Hz/cm^2
- **lower half** receive a flux lower by four orders of magnitude (10^4 Hz/cm^2)

Data Acquisition System at GIF++ facility

How to identify the aging effect?

- Impossible to measure all performance and characteristics during the irradiation test.
 - Requires specific experimental condition (beam, low energy X-ray, etc.)
 - Probability to disturb the system during the irradiation test
- Aging → Effective Gas Gain → Performance/Characteristics

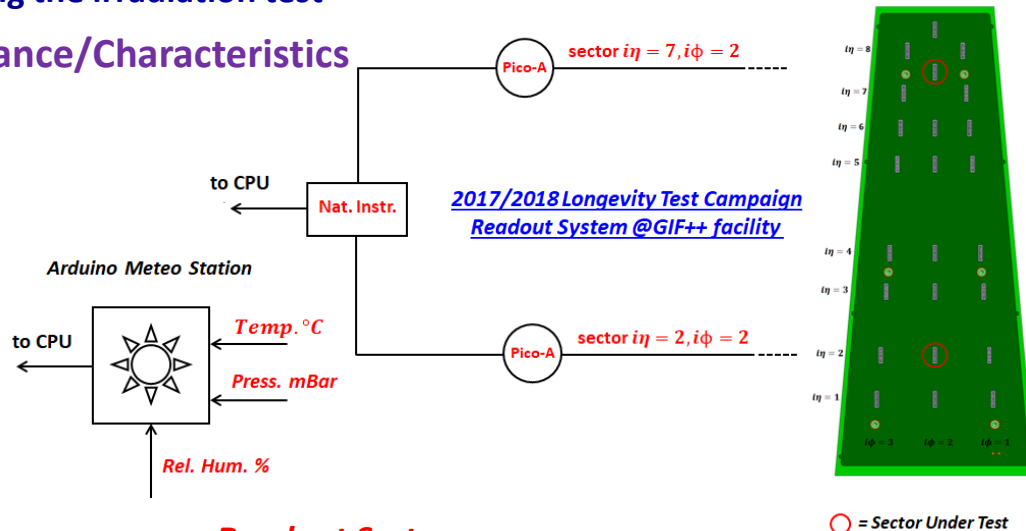
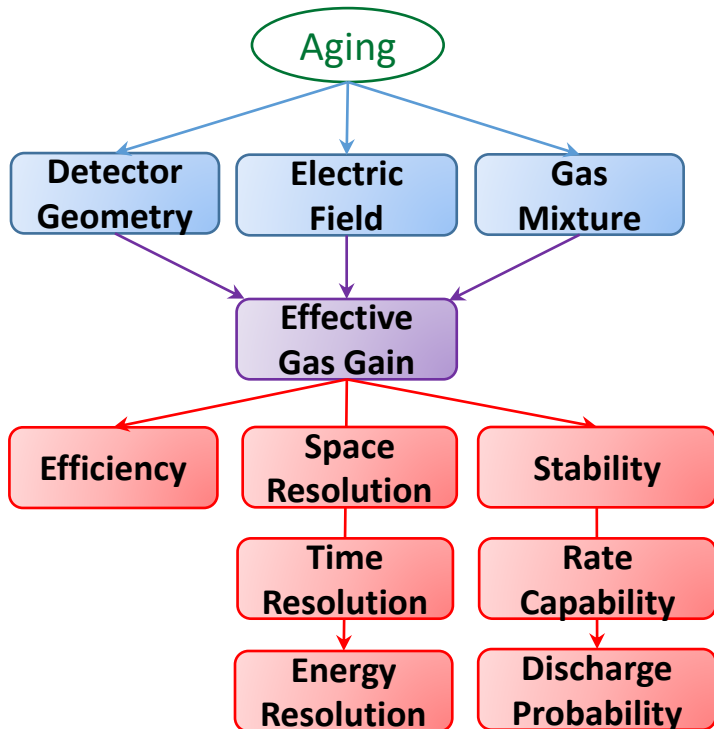

Readout System:
2 pico-ammeters to monitor the anode current during the irradiation test.

Meteo Station:
Meteo Station inside the GIF++ bunker to monitor environmental parameters.

Experimental Setup at CMS-GEM facility (904)

- QA/QC X-ray station adapted for longevity studies
- Source: 22 keV X-ray photons from X-rays generator
- Detector: LS2-GE1/1 detector with the final geometry and materials

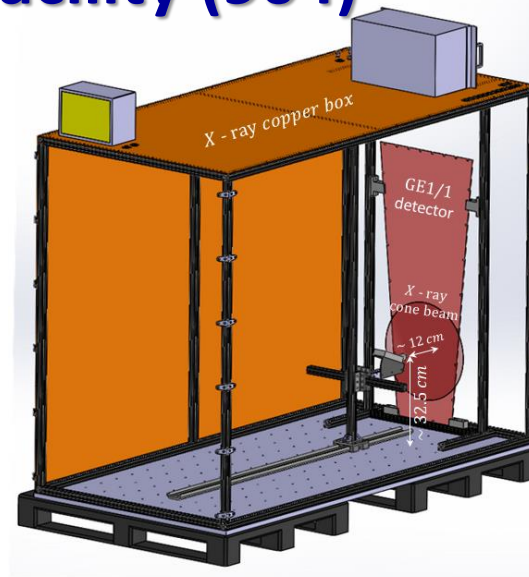

X-ray configuration:

The X-Ray gun has been placed at 12cm from the detector in order to:

- Maximize anode current and accelerate aging studies (5 months instead 5.5 years at GIF++ facility)
- Irradiate the GEM-foils, external / internal frame, O-ring, etc.

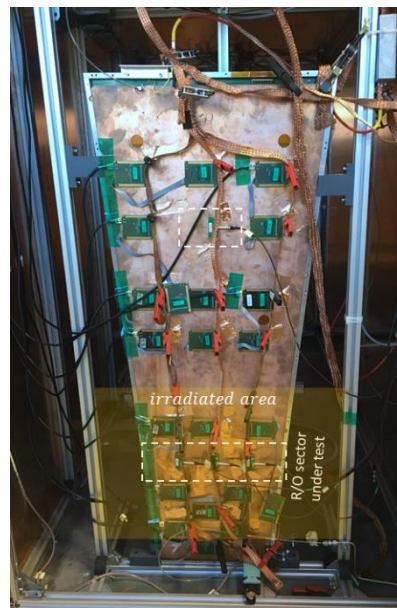
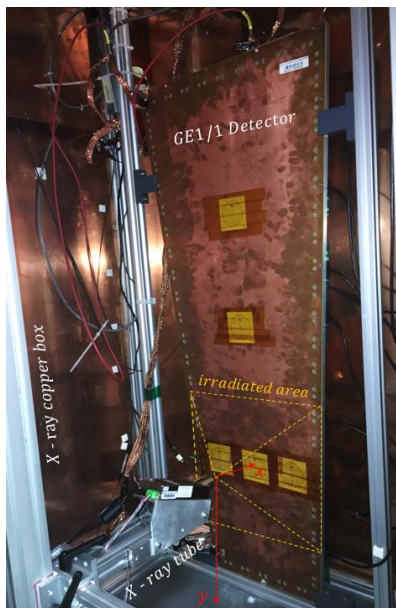

Data Acquisition and Analysis Procedure

2017/2018 Longevity Test Campaign
Readout System @ CMS-GEM QA/QC Lab.

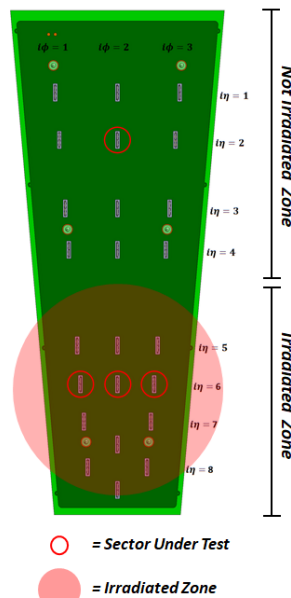
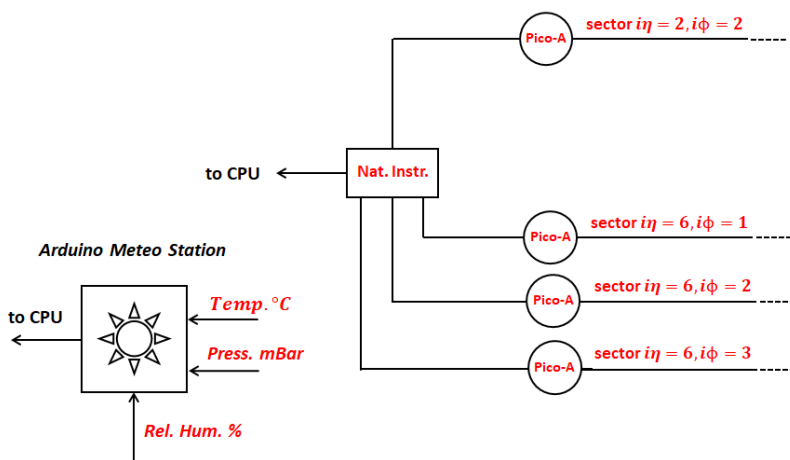

2017/2018 Longevity Test Campaign
Analysis Procedure

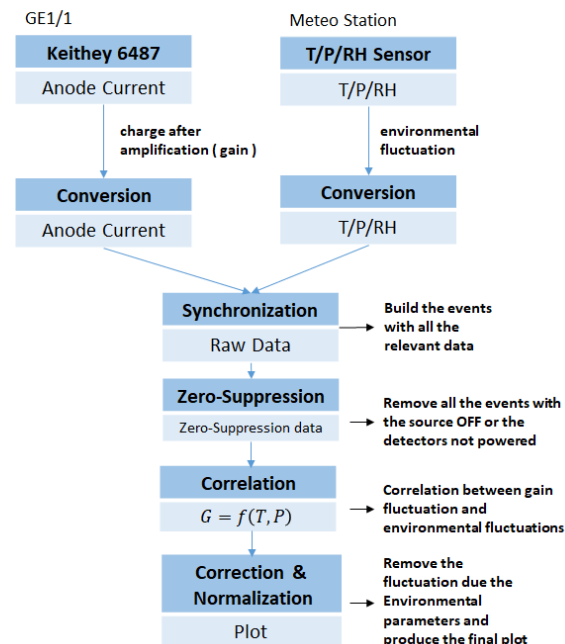

Readout System:

3 pico-ammeters on the irradiated zone to monitor the anode current during the irradiation test

1 pico-ammeter on the non-irradiated zone as a reference during the irradiation test

Meteo Station:

Arduino Meteo Station inside the X-ray copper box to monitor environmental parameters.

During the irradiation test, in addition to the monitoring of the anode current:

- The *effective gas gain* and the *energy resolution* have been continuously measured every week on the readout sectors under test.
- The *gas gain map uniformity* measurements have been performed every month to check for the gas gain variation between the irradiated and non irradiated detector active area.

Accumulated Charge and Anode Current Measurement @ GIF and 904

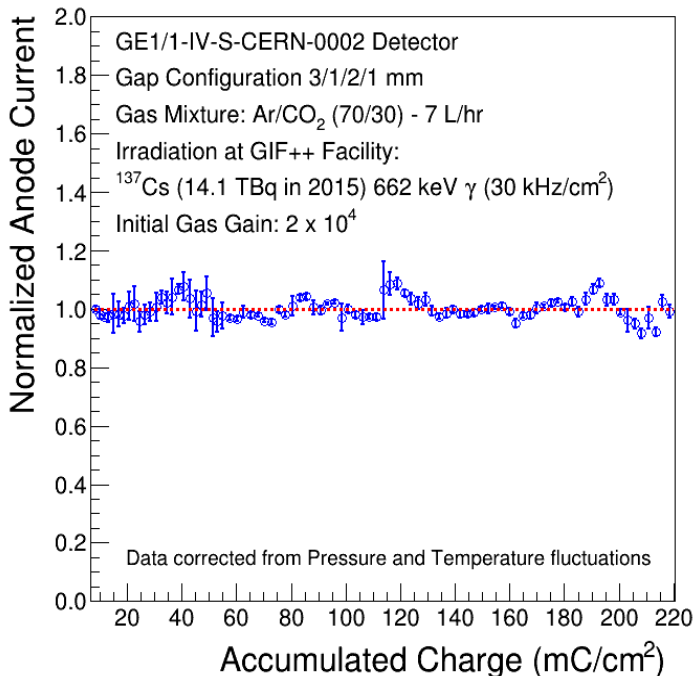

GIF++ Triple-GEM aging test. Normalized anode current as a function of the accumulated charge. Chamber operating in Ar/CO₂ (70/30) at an initial gas gain of 2×10^4 equipped with CERN GEM-foils based on single-mask photolithography technique developed by CERN PCB Workshop; The chamber accumulated a total charge of 218mC/cm² after 28 months of continuous irradiation

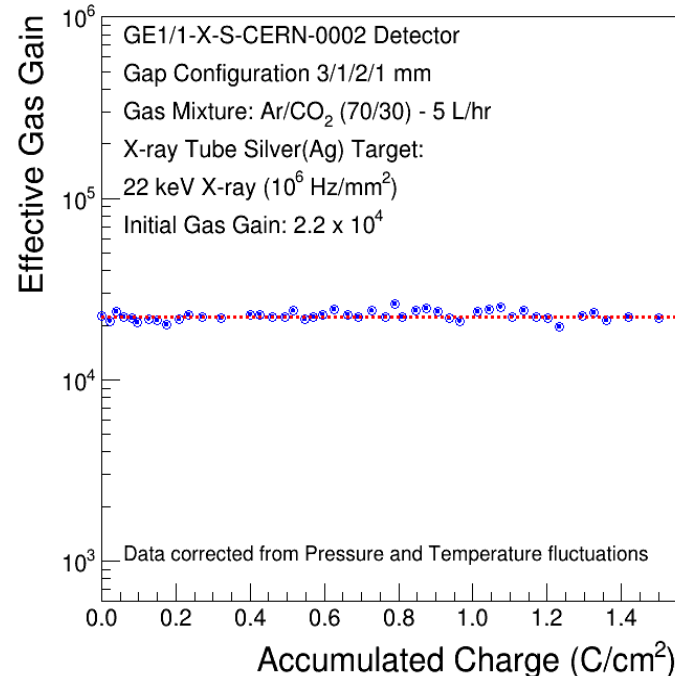

X-ray Triple-GEM aging test in 904; Normalized gas gain as a function of the accumulated charge Chamber operating in Ar/CO₂ (70/30) at an initial gas gain of 2×10^4 equipped with CERN GEM-foils based on single-mask photolithography technique developed by CERN PCB Workshop; The chamber accumulated a total charge of 1.56 C/cm² after 18 months of continuous irradiation

Annex E (Triple GEM Longevity Studies)



Weekly Energy Resolution Measurement in 904 setup

(i. e. every $\sim 30 \text{ mC/cm}^2$)

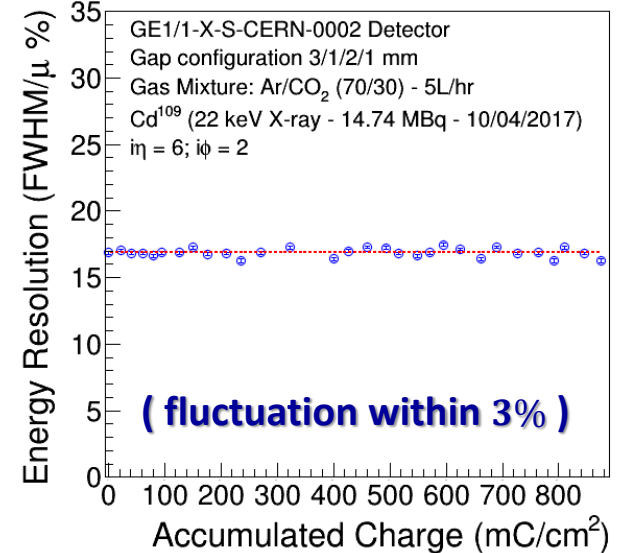
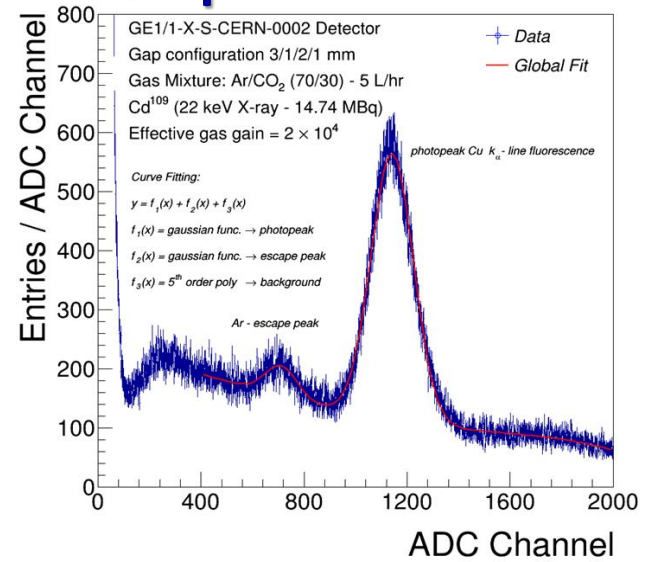
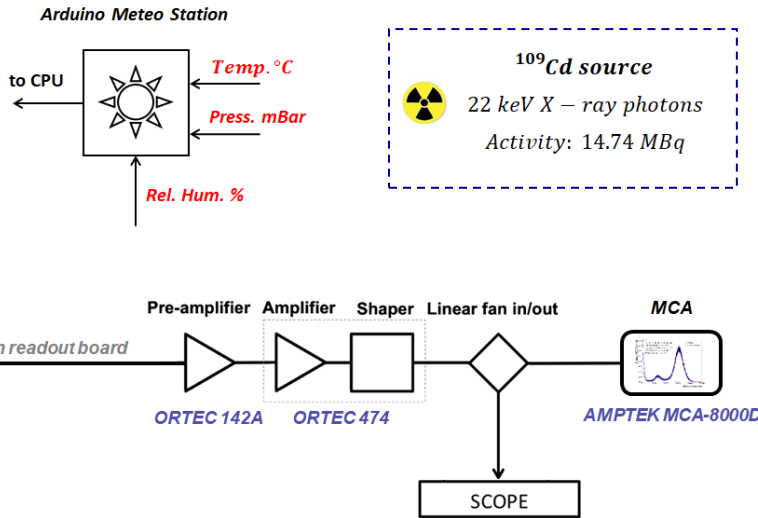
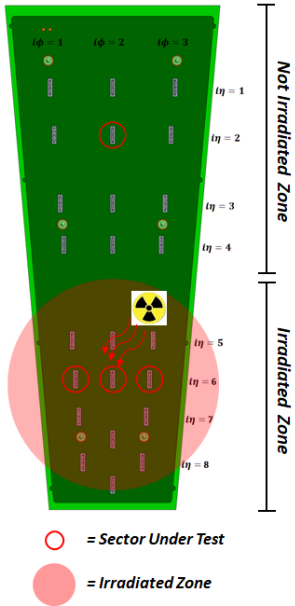

The experimental data are modeled by the function:

$$y = f_1(x) + f_2(x) + f_3(x)$$

$$f_1(x) = \text{gaussian func.} \rightarrow \text{photopeak} \rightarrow \left\{ \begin{array}{l} \text{photopeak sigma value } \sigma \\ \text{photopeak mean value } \mu \end{array} \right.$$

$$f_2(x) = \text{gaussian func.} \rightarrow \text{escape peak}$$

$$f_3(x) = \text{5th order poly} \rightarrow \text{background}$$

$$\text{Energy Resolution} \frac{FWHM}{\mu} \% = \frac{2\sqrt{2\ln(2)} \sigma}{\mu} \%$$

Advanced Longevity Studies:

- Investigate aging issues originated by particles with different ionization powers to properly represent the long-term gaseous detector behavior in real experiments:

^{241}Am : 5.6 MeV α - particle and ^{55}Fe : 5.9 keV X-rays



GEM 10x10 prototype

Detector under test:

- GEM $10 \times 10 \text{ cm}^2$ prototype irradiated in two different sectors

Method to accelerate the aging:

- Contaminate the gas mixture with pollutants (hydrocarbons and Si - based molecules)

SEM and EDS analysis to study polymer density around GEM holes

X - rays irradiated hole

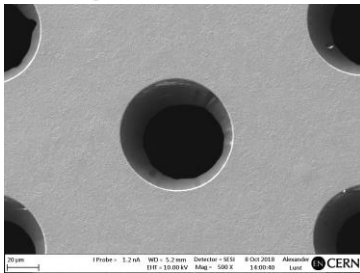

- Light Si deposits on the top layer around the holes (2 - 3 μm)
- Perfectly clean surface on the bottom side

α - particles irradiated hole

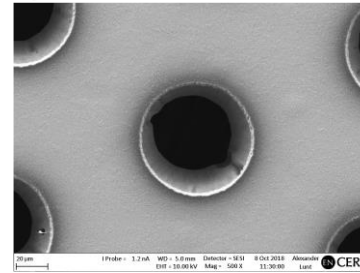

- Si deposits on the entire top and bottom surface with larger structure in a strip of 10 - 15 μm around the holes



Backup



The activity of 2017 included a **study of stability** of triple-GEM detectors into the CMS environment

Single HV channel

→ **high voltage fluctuations < 1%** observed in a period of 7 hours during LHC collisions ($L_{max} \approx 1.1 \times 10^{34} \text{cm}^{-2} \text{s}^{-1}$)



Multichannel HV

→ **high voltage fluctuations < 1%** observed for all 7 HV channels in a period of 12 hours during LHC collisions

($L_{max} \approx 9.3 \times 10^{33} \text{cm}^{-2} \text{s}^{-1}$)



LV channels

→ LV channels showed the same stability both with and without beam

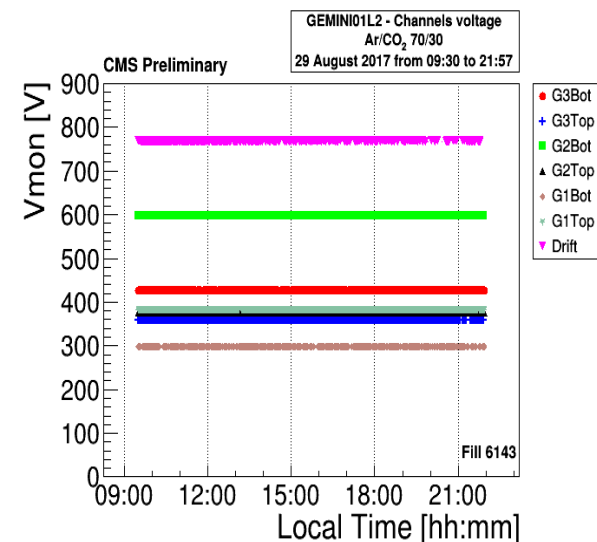
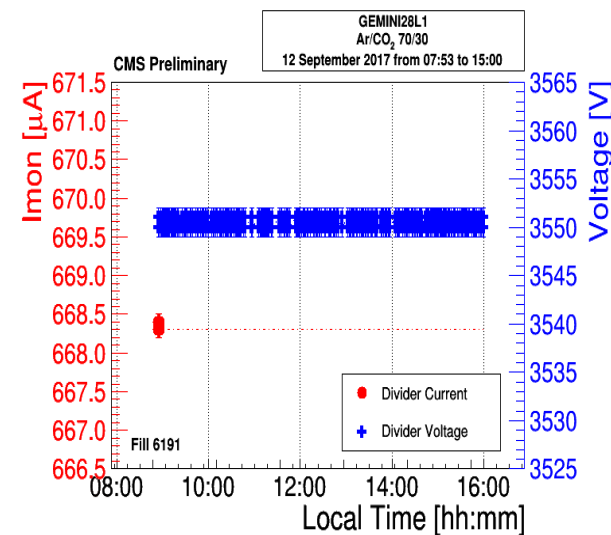

Mastering GEM

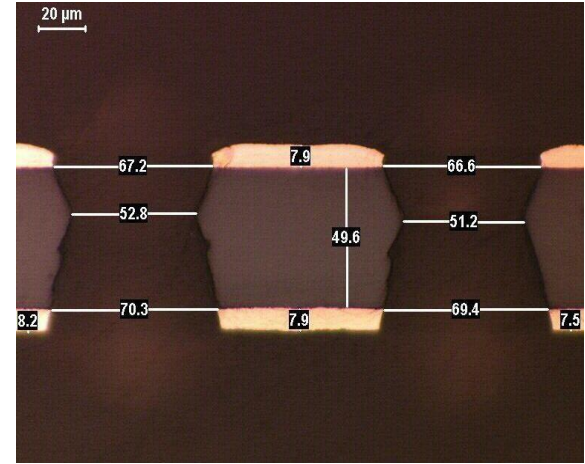
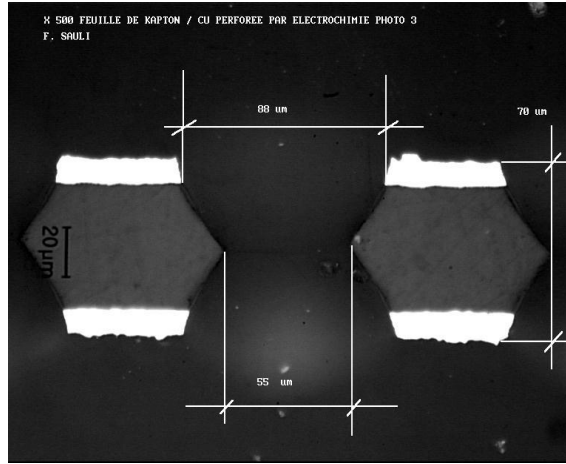
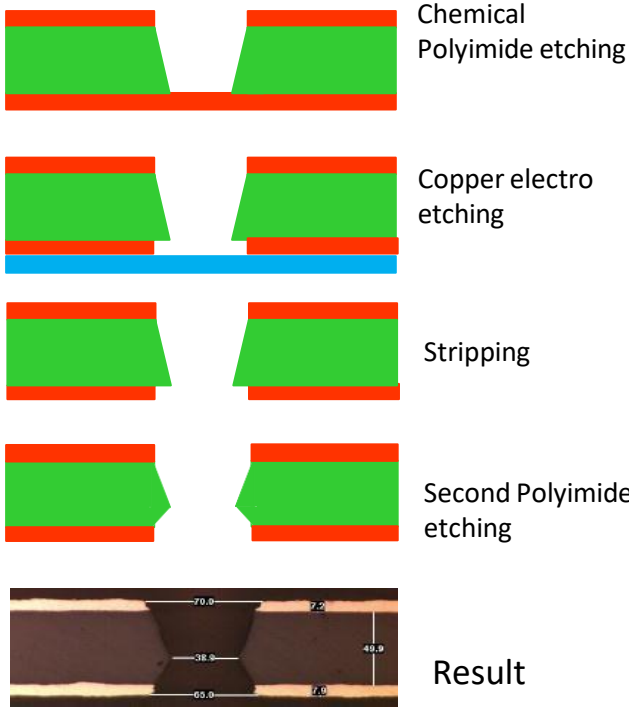

- Similar patterns , similar behavior, same material.
 - Angles can be adjusted in both structure (Typ. value : 70um copper hole , 50um polyimide hole)
- Steeper angles give lower gain but also reduced charging up**

Goals: Test the connectivity of the electronics components, monitor the communication stability, check noise level and output signals

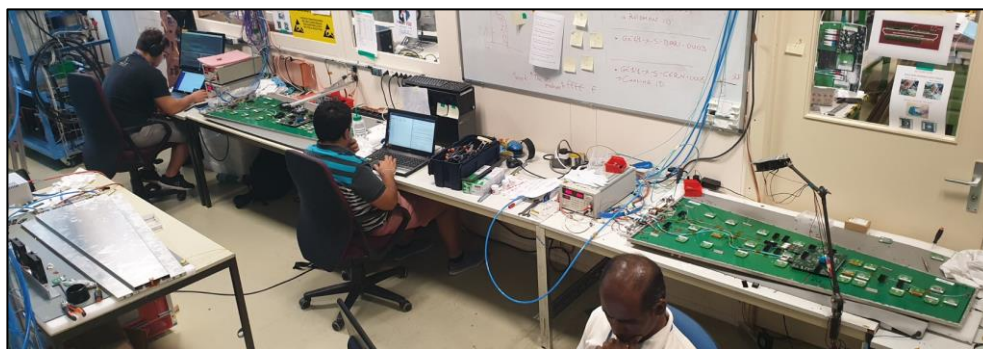

- Connectivity
- Calibration
- Identification of dead/hot channels
- Global threshold scans (SBIT line) per VFAT
- ENC measurement (S-curves)
- Local threshold scans (SBIT line) per channel (to identify disconnected channels)

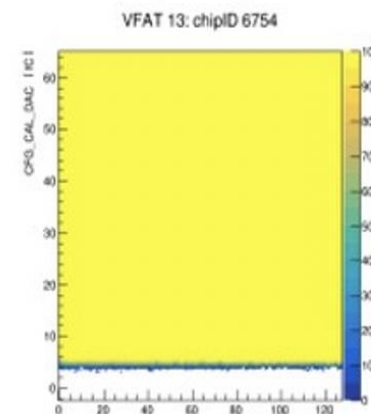
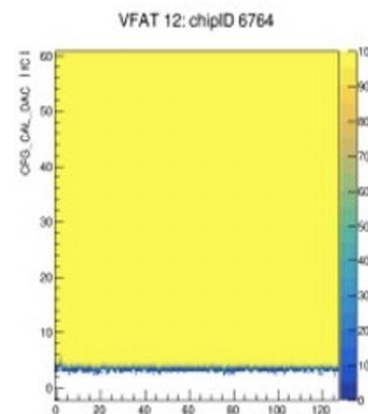

The entire procedure is repeated after mounting the cooling plate and the chimney

Production schema, material flow and validation/certification as for GE1/1

- Mass-production organized in parallel in several production sites, at CERN and outside (same as GE1/1)
- 8 production sites:
 - 6 already participated to GE1/1
 - 2 new sites already validated
- Dedicated pre/post-production teams
- Chambers assembly & validation at CERN, as for GE1/1, with the contribution of the whole GEM community

Note: Additional training sessions and refreshing courses are continuously organized in 904



- **Vendors**
 - Manufacturing of the detector components
 - Shipment to CERN
- **Central Site (at CERN)**
 - Material inspection (QC1/QC2)
 - Pre-assembly work
 - Preparation of assembly kits
 - Shipment to/back from production sites
- **Production Sites**
 - Module assembly
 - QC2-QC5 tests
 - Data Base updates

