

Eucard WP 10.8

(Orsay, 5 May, 2011)

W. Kaabi, Y. Peinaud, A. Thiebault, E. Herry, A. Variola, M. Lacroix,
F. Letellier-Cohen, B. Mercier and C. Prevost

Eucard WP10.8



Summary

- Introduction
- Automatic Cleaning System
- Plasma Discharge Cleaning
- Schedule

Introduction

Coupler preparation

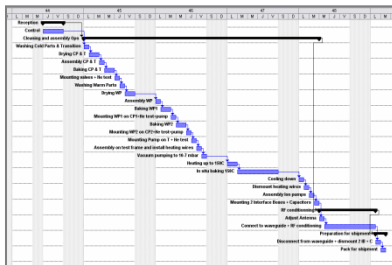

Cold coupler part

Warm coupler part



Coupler parts after manufacturing

3 Weeks

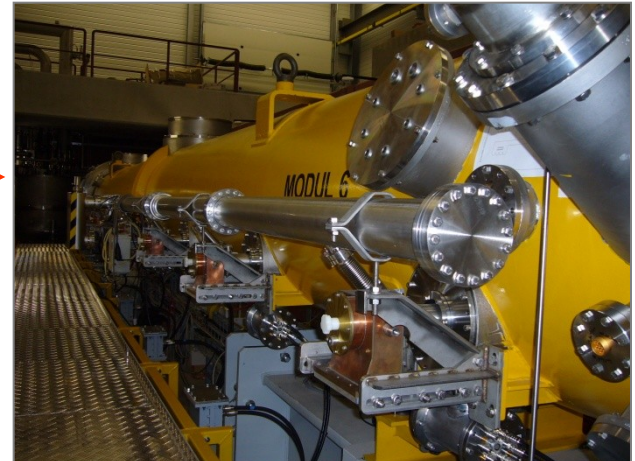

Cryomodule assembly

Cleaning

Assembling

Desorption

Conditioning

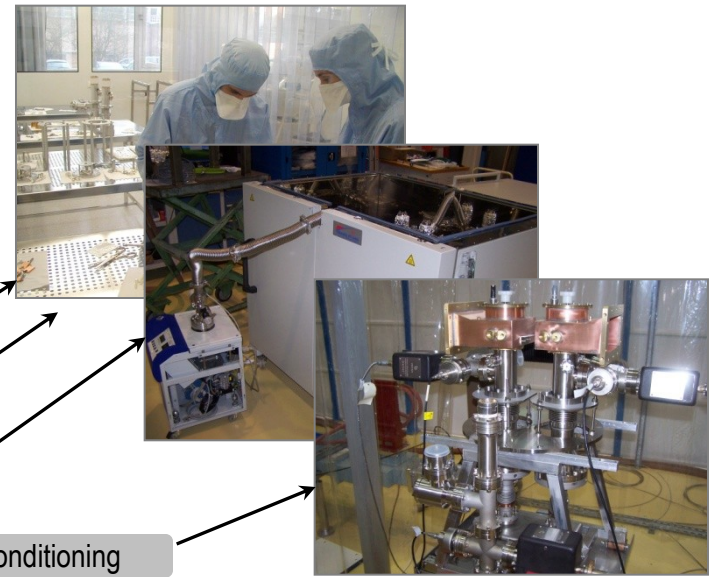

Global goals

- For mass production (ILC, 16000 couplers?) : improve quality and reduce the time of the preparation

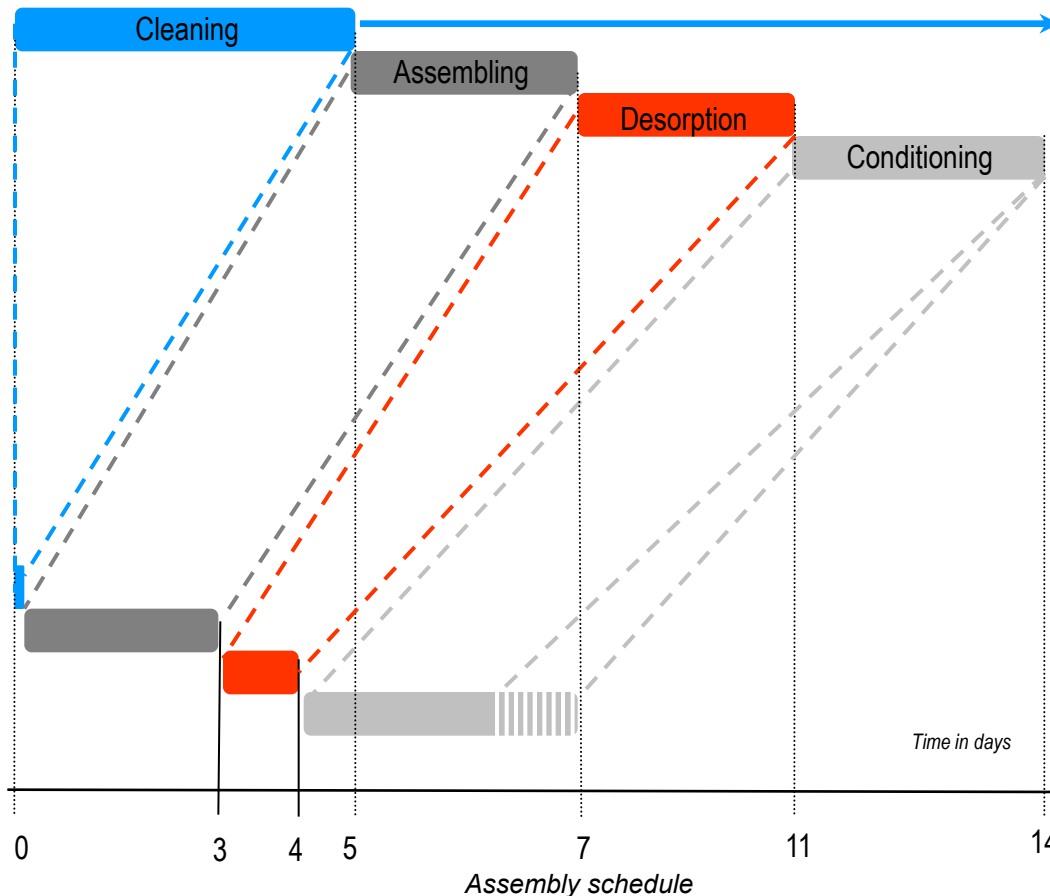

- Actual process
 - 5 days
 - No repeatability
 - Pollution risk from manual handling
- Automatic Cleaning System
 - 3 hours
 - Full repeatability and control of each parameters
 - No handling but risk of pollution due to the machine → Main challenge

Eucard WP 10.8.2

Cleaning

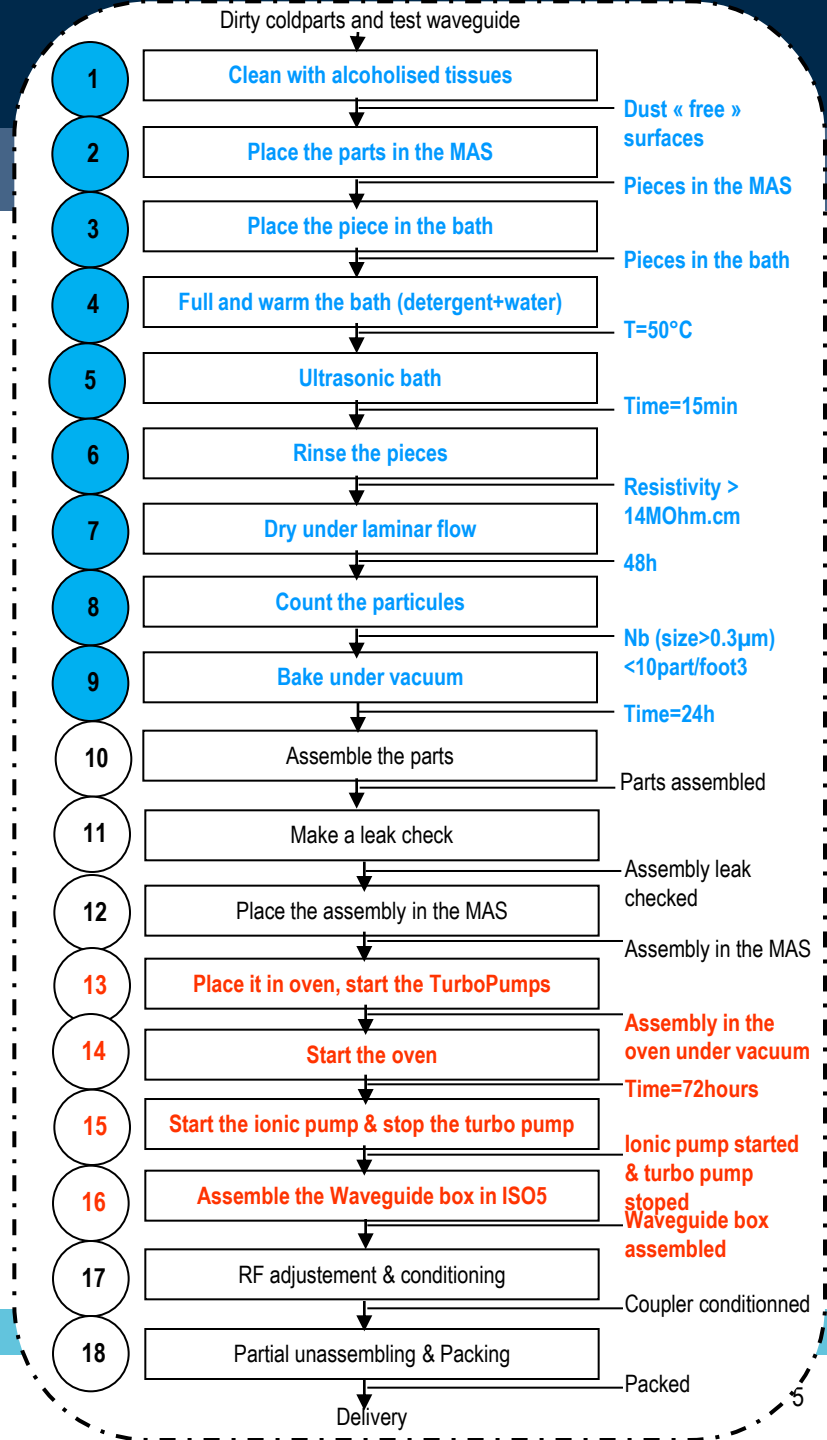
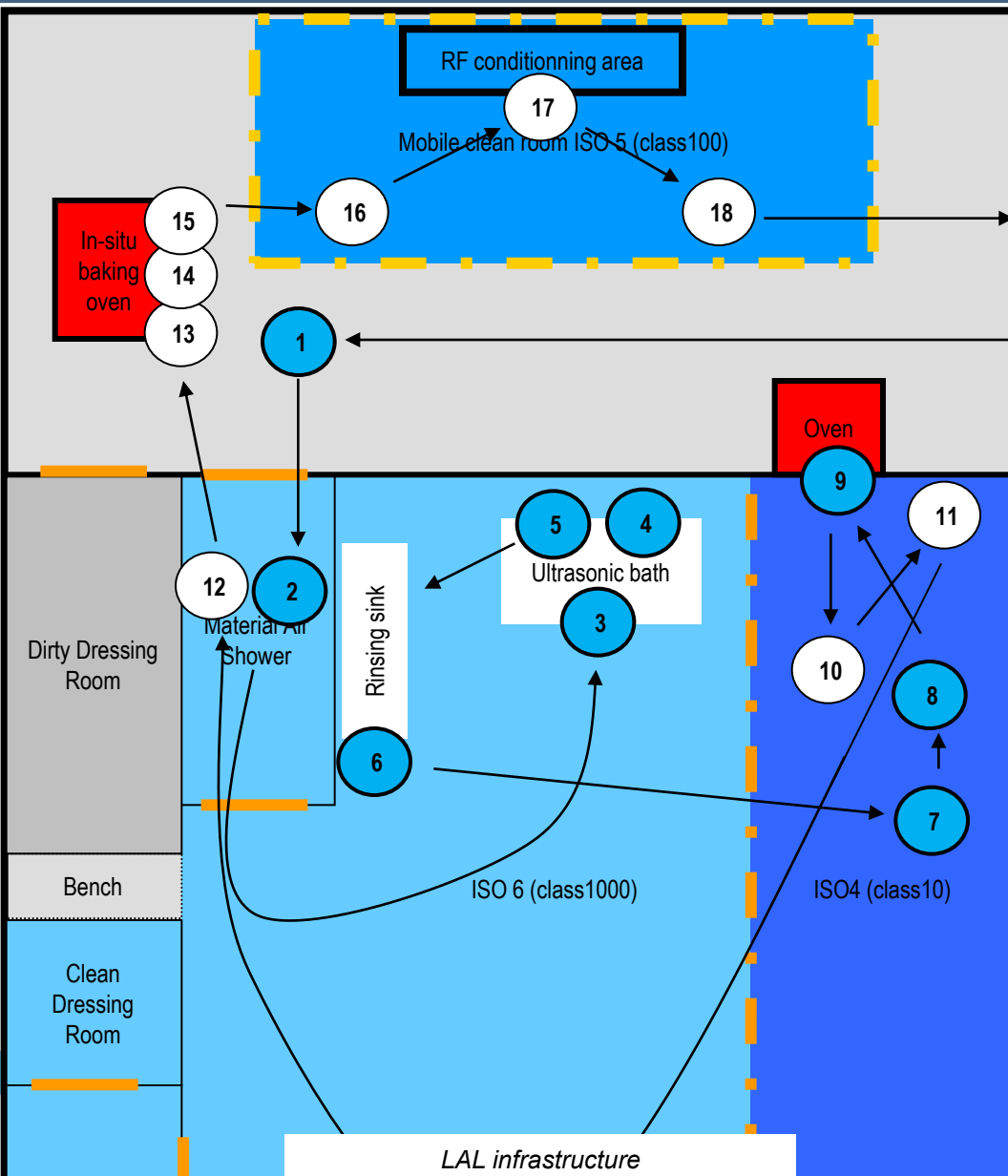

Automatic Cleaning System

- Integration: → Service hatch
 - The machine can be load and started by o
 - No clean-room contamination due to the m

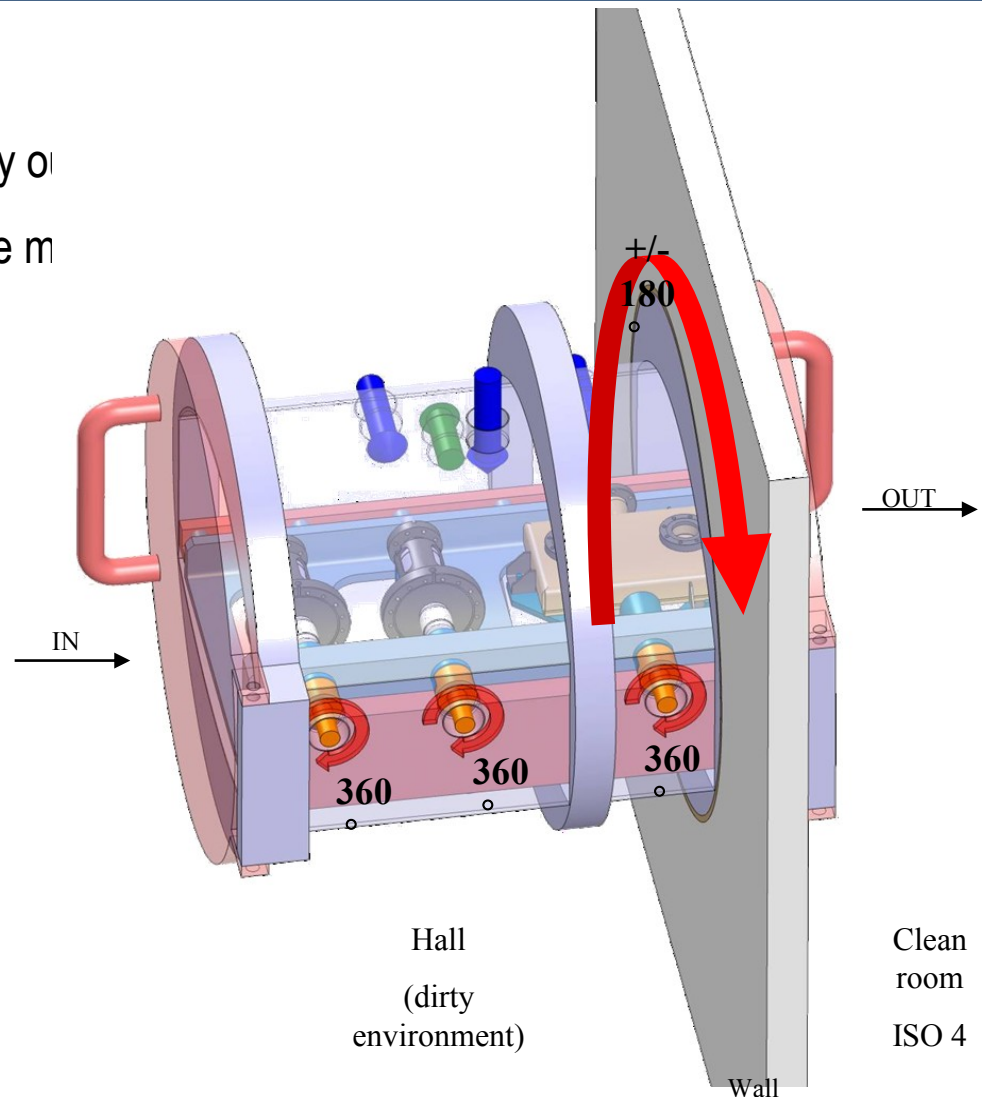
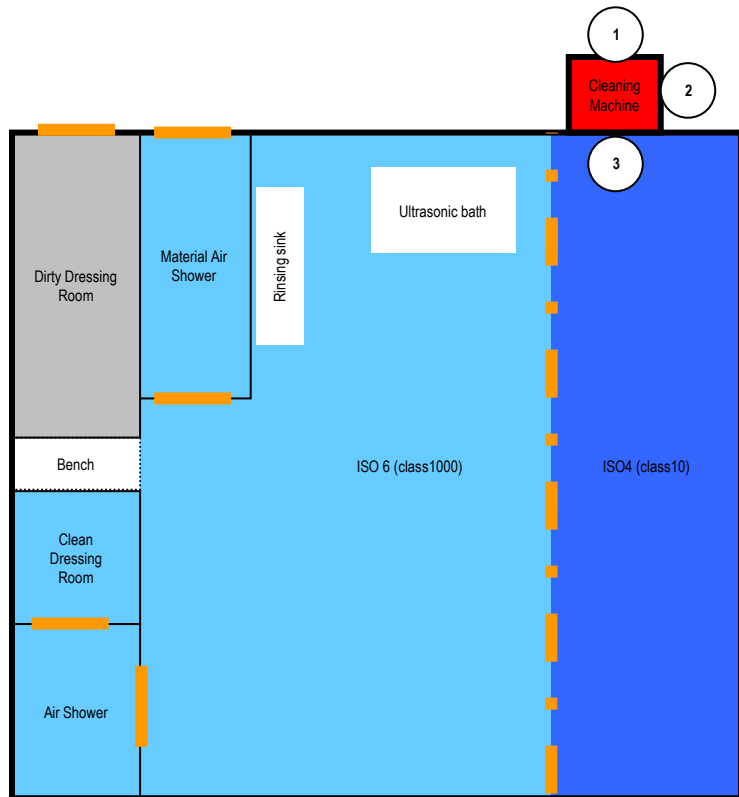

Automatic Cleaning System

- Logical Synoptic of the full cleaning cycle
 - Ultrasonic washing
 - Rinsing
 - Resistivity measurement
 - Air drying

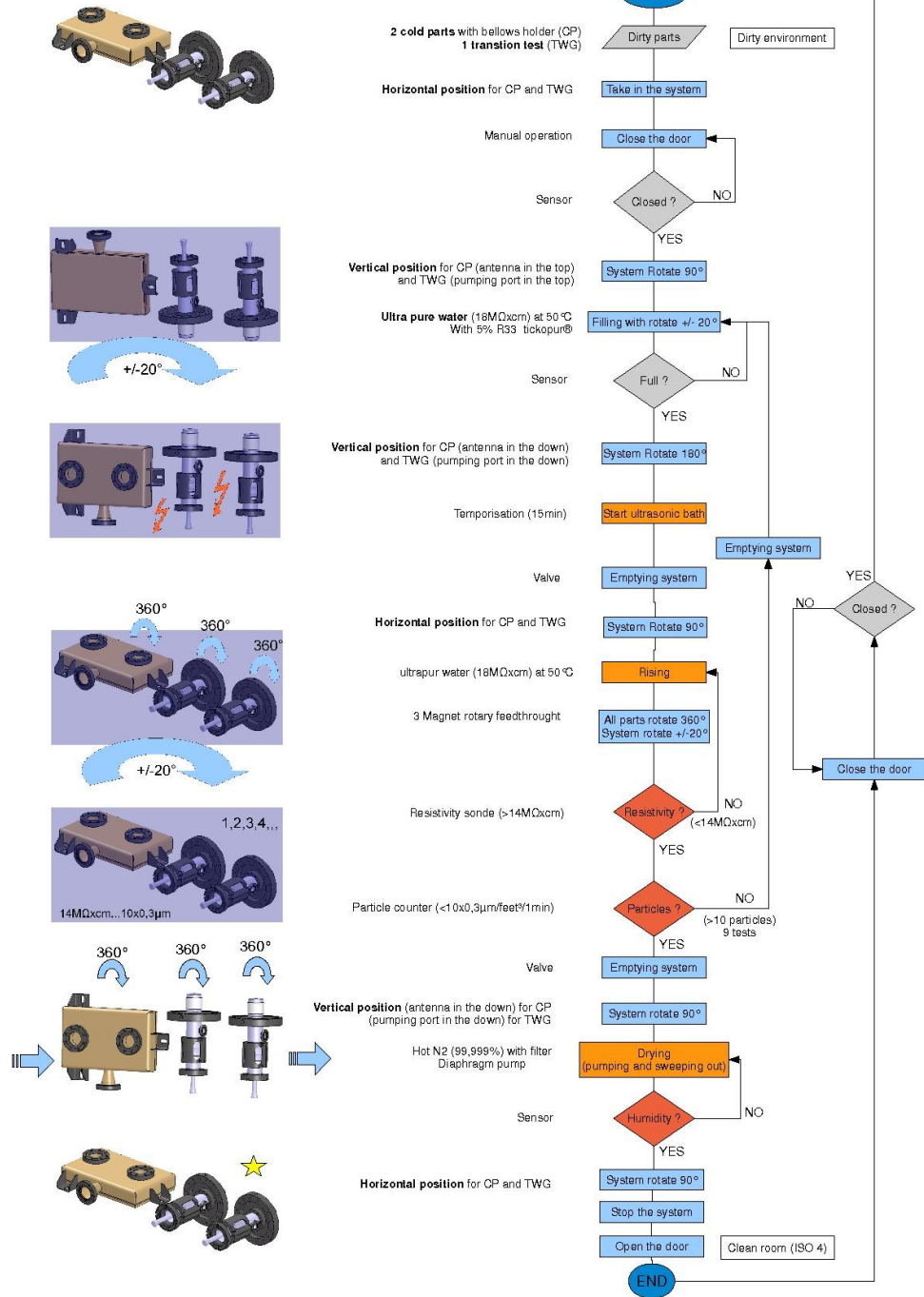
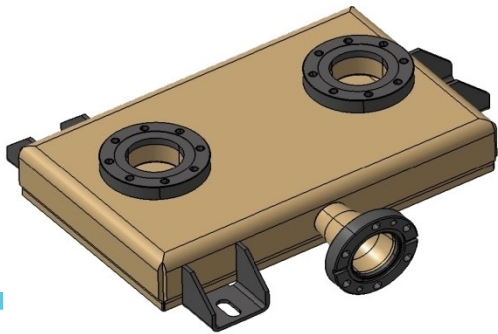
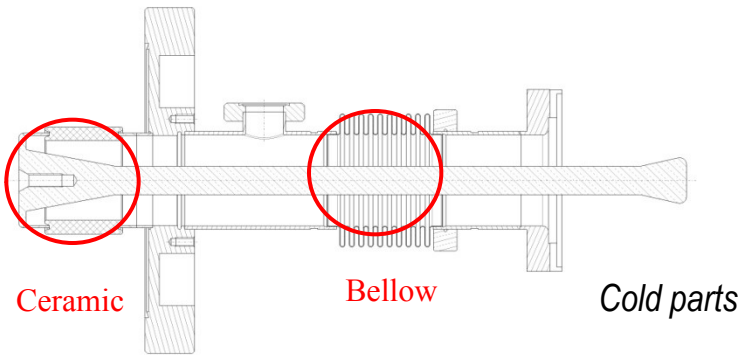

Automatic Cleaning System

- Motion:
 - A first rotation around the axle of the device
 - A second rotation around the axle of each
 - Dust free & UltraPure water resistant
 - Special materials
 - Stainless steel
 - PVDF
 - Titanium
 - No friction
 - Ball bearings
 - Magnetic coupling

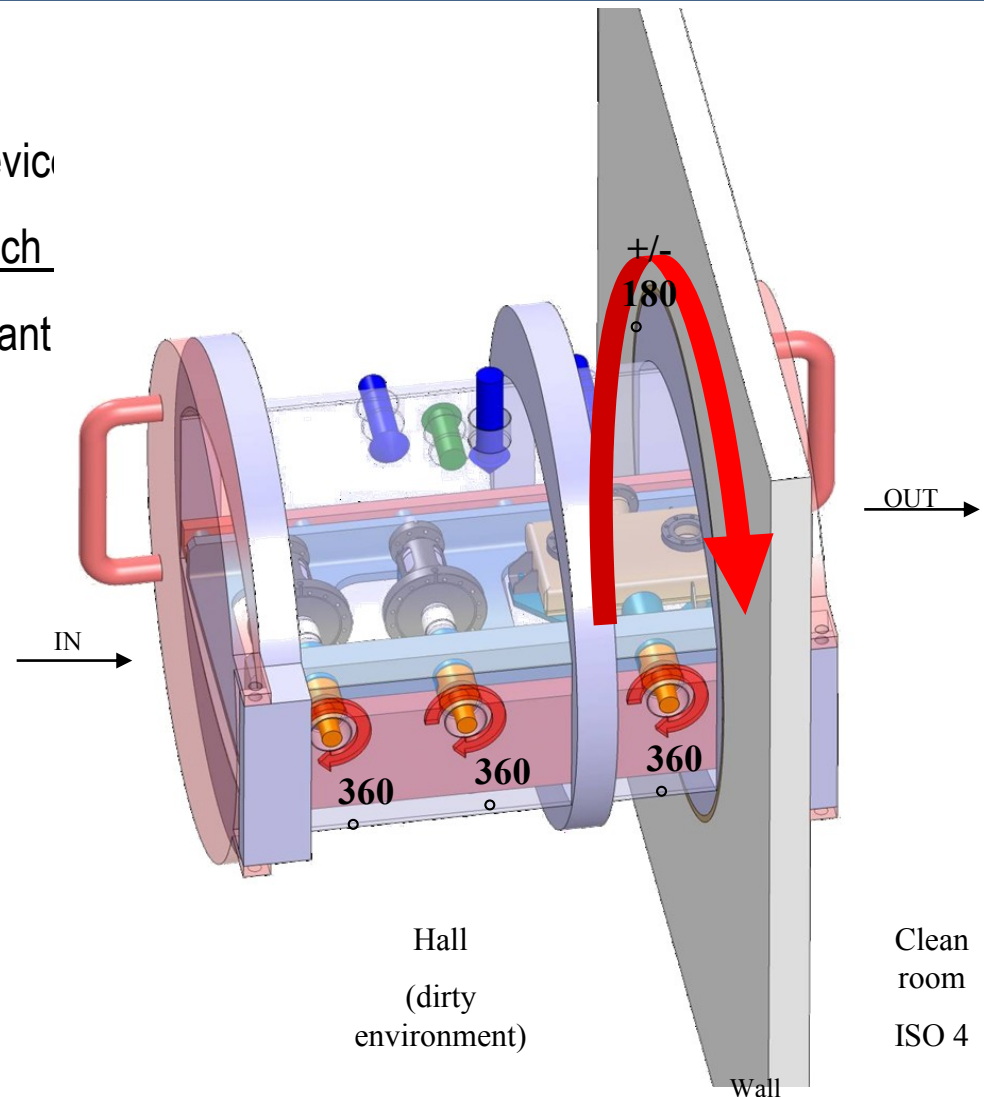

Automatic Cleaning System

- Design of the chan

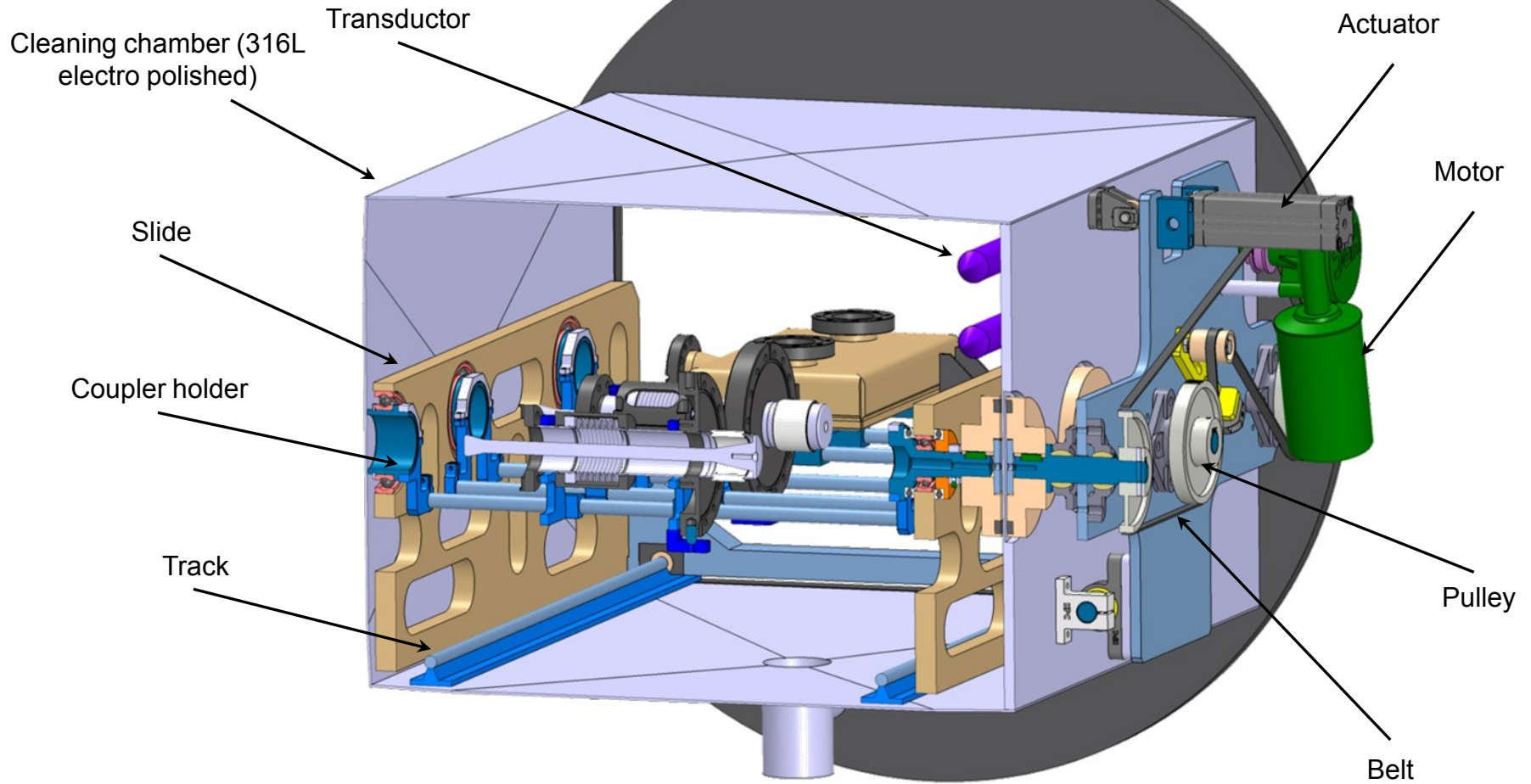

Automatic Cleaning System

- Design of the main motion

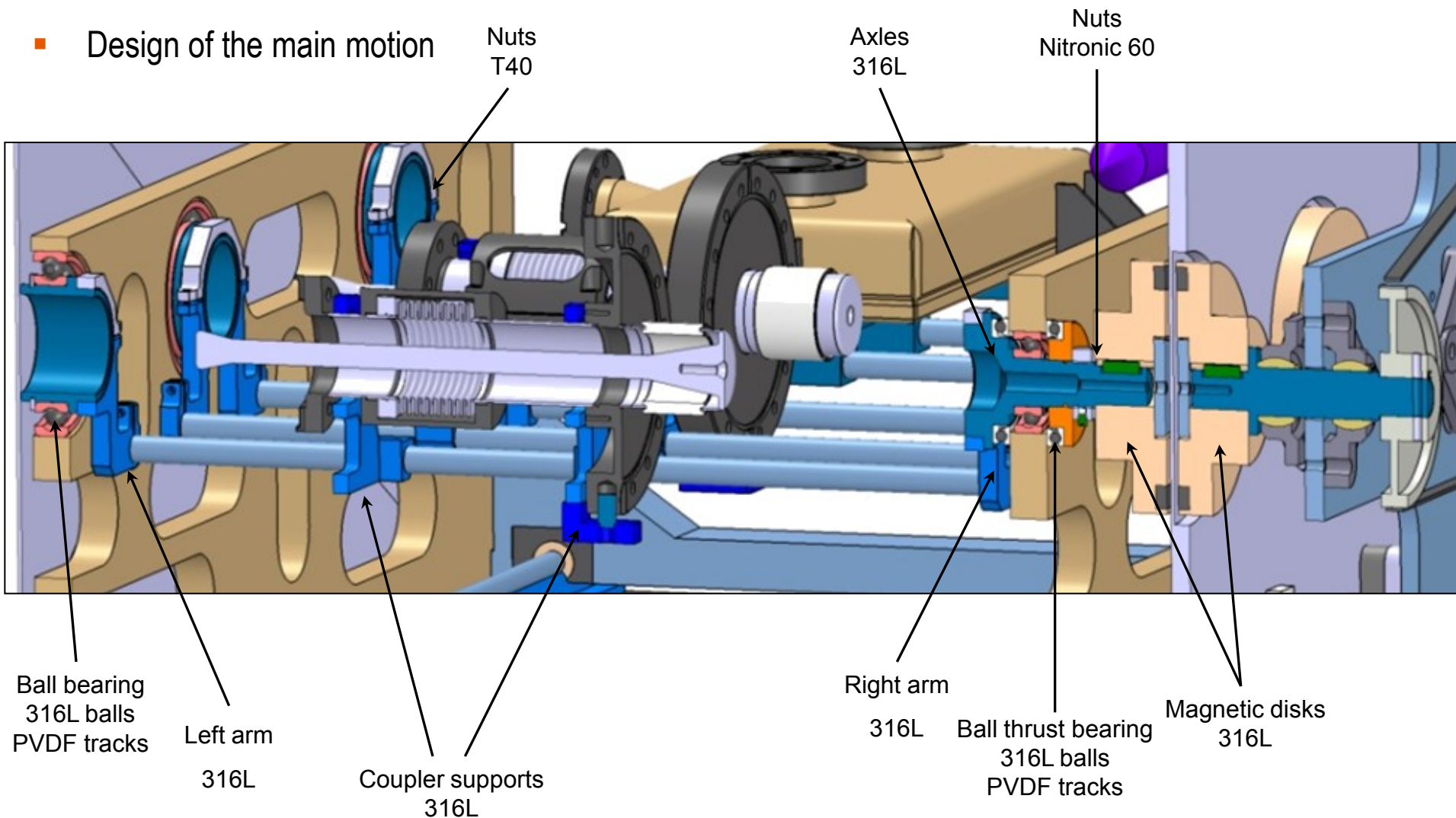

Automatic Cleaning System

- Coupler holder test
 - Test bench production → end of May
 - Particules tests → beginning of June (2weeks)

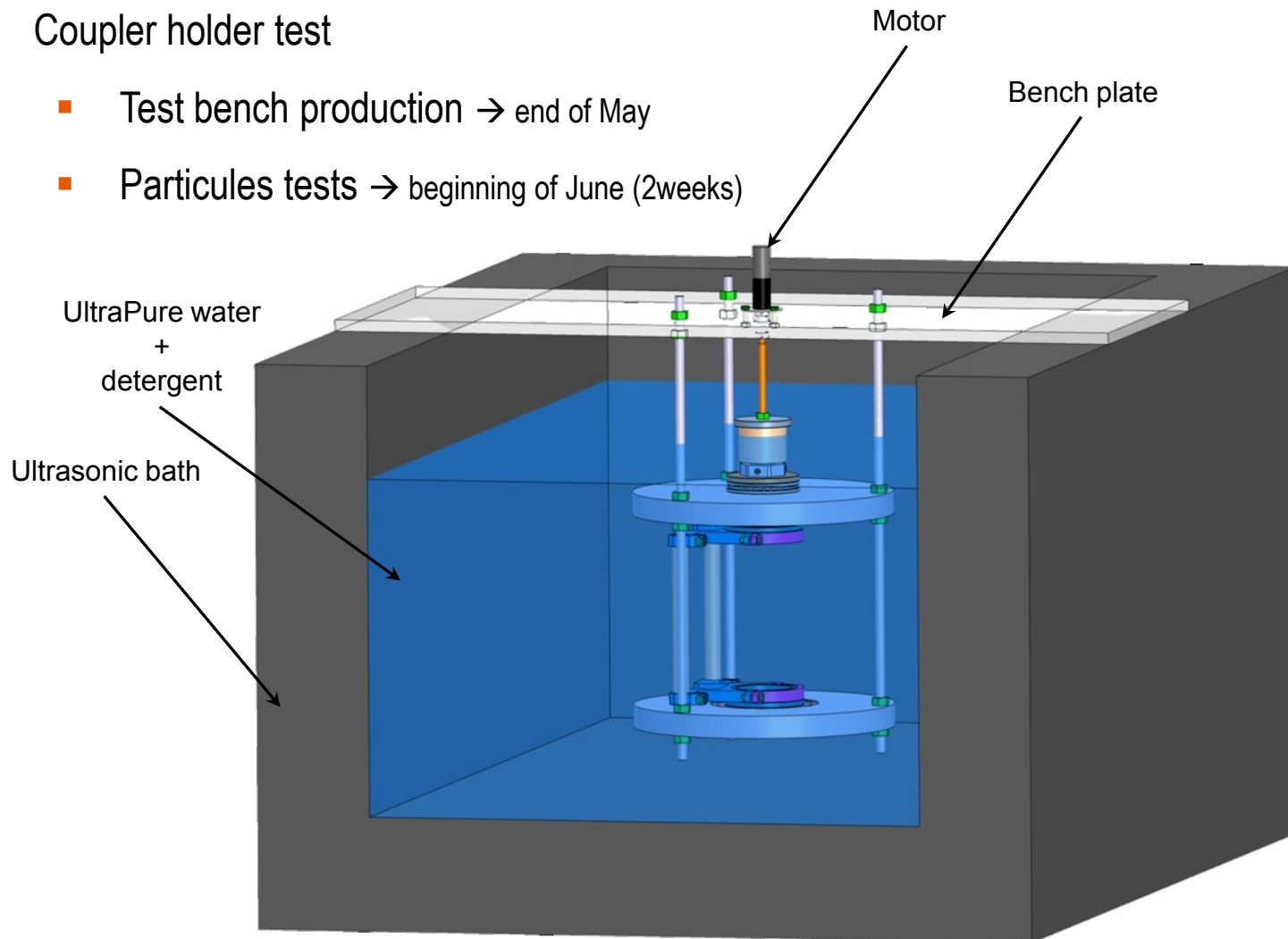

Thank you