

Electron-Ion Collider Overview

2nd FCC EPOL Workshop
19 September 2022

F. Willeke, BNL

Electron-Ion Collider

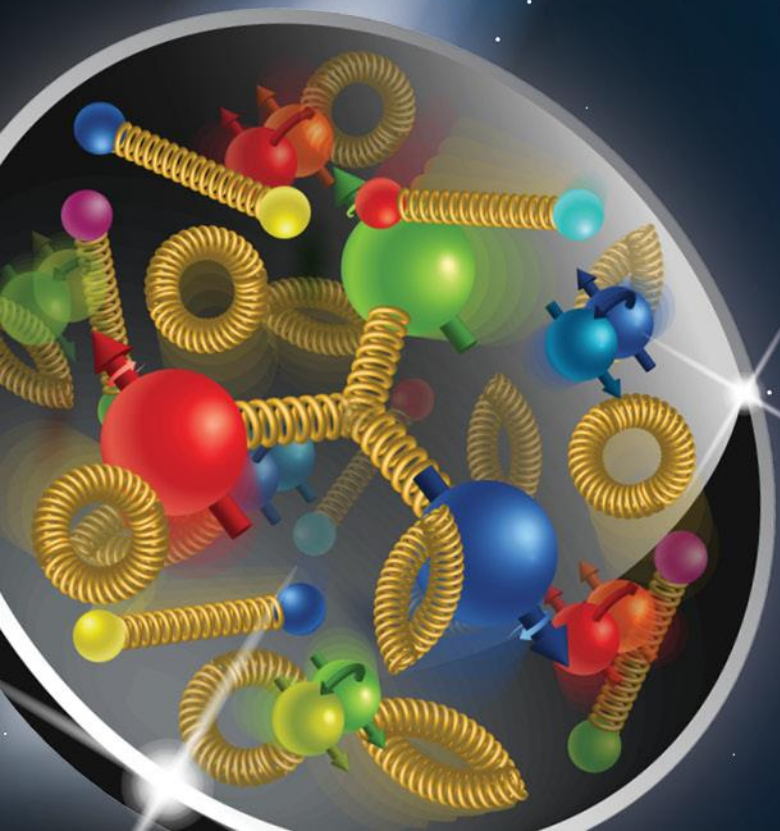

Outline

- Requirements
- Scope and design Overview
- Recent Progress on Accelerator
 - Global accelerator design, beam interaction, polarization, strong hadron cooling
- Progress on accelerator R&D
 - Vacuum, SC RF, SC IR magnets
- Summary

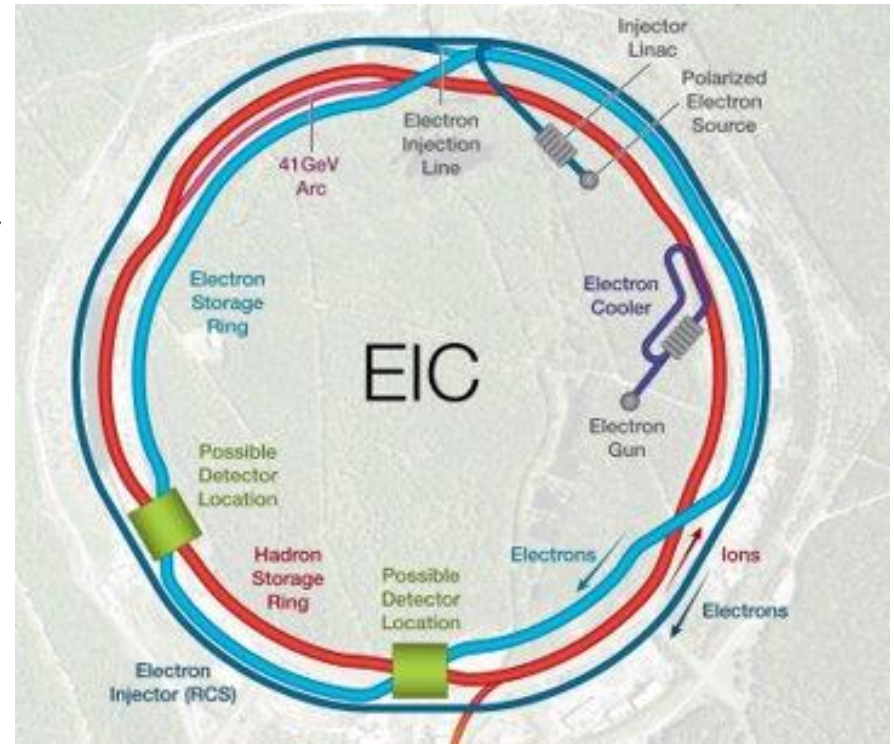

Requirements

- EIC Design Goals
 - High Luminosity: $L=(0.1-1)\cdot 10^{34}\text{cm}^{-2}\text{sec}^{-1}$, need 10 -100 fb^{-1}
 - Collisions of highly polarized e and p (and light ion) beams with flexible bunch by bunch spin patterns : 70%
 - Large range of center of mass energies: $E_{\text{cm}} = (20-140) \text{ GeV}$
 - Large range of Ion Species: Protons – Uranium
 - Ensure Accommodation of a second IR
 - Large detector acceptance
 - Good background conditions (hadron particle loss and synchrotron radiation in the IR)
- Goals match or exceed requirements of Long-Range Plan & EIC White Paper, endorsed by NAS
- EIC Design meets or exceeds goals and requirements

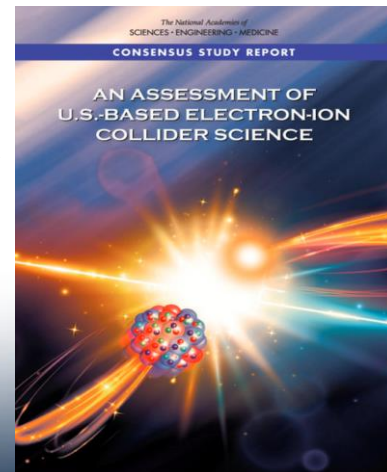
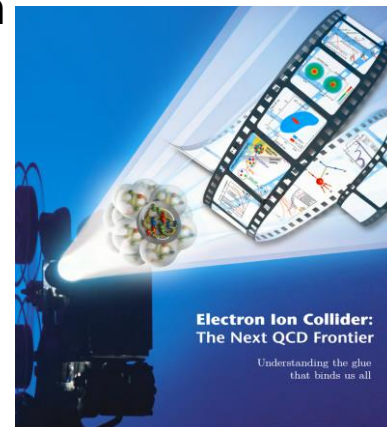
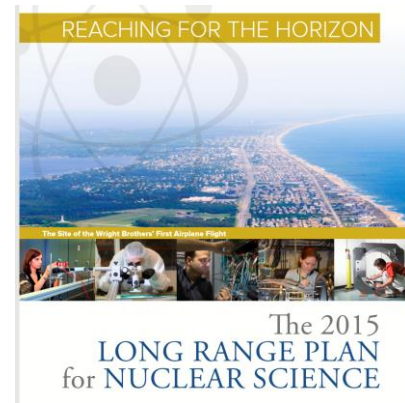

Electron-Ion Collider

EIC Design Overview

Design based on **existing RHIC Complex**
RHIC is well maintained, operating at its peak

- **Hadron storage Ring (RHIC Rings) 40-275 GeV (existing)**

- 1160 bunches, 1A beam current (3x RHIC)
- bright vertical beam emittance 1.5 nm
- strong cooling (coherent electron cooling)

- **Electron storage ring 2.5–18 GeV (new)**

- many bunches,
- large beam current, 2.5 A → 9 MW S.R. power
- S.C. RF cavities
- Need to inject polarized bunches

- **Electron rapid cycling synchrotron 0.4- 18GeV (new)**

- 1-2 Hz
- Spin transparent due to high periodicity

- **High luminosity interaction region(s) (new)**

- $L = 10^{34} \text{cm}^{-2}\text{s}^{-1}$
- Superconducting magnets
- 25 mrad Crossing angle with crab cavities
- Spin Rotators (longitudinal spin)
- Forward hadron instrumentation

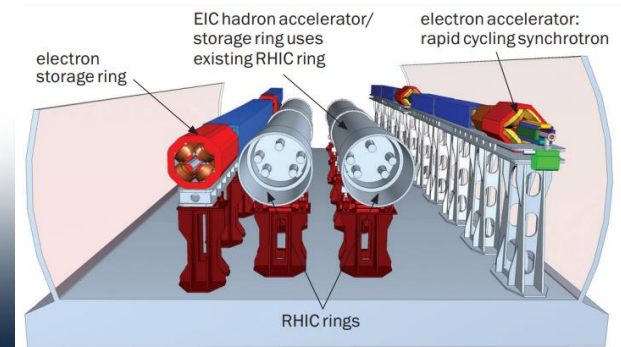
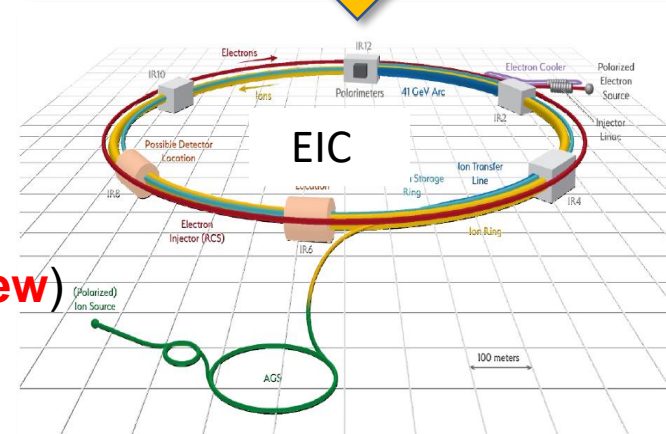

EIC CDR Parameters for E_{cm} and Luminosity

	Electrons	Protons
Beam energies	2.5 - 18 GeV	41- 275 GeV
Center of mass energy range	$E_{cm} = 20-140$ GeV	

	Electrons	Protons
Beam energies	10 GeV	275 GeV
Center of mass energy	$E_{cm} = 105$ GeV	
number of bunches	nb =1160	
crossing angle	25 mrad	
Bunch Charge	$1.7 \cdot 10^{11}e$	$0.7 \cdot 10^{11}e$
Total beam current	2.5 A	1 A
Beam emittance, horizontal	20 nm	9.5 nm
Beam emittance, vertical	1.2 nm	1.5 nm
β - function at IP, horizontal	43 cm	90 cm
β - function at IP, vertical	5 cm	4 cm
Beam-beam tuneshift, horizontal	0.073	0.014
Beam-beam tuneshift, vertical	0.1	0.007
Luminosity at $E_{cm} = 105$ Gev	$1 \cdot 10^{34} \text{cm}^{-2} \text{s}^{-1}$	

Luminosity vs. CM Energy

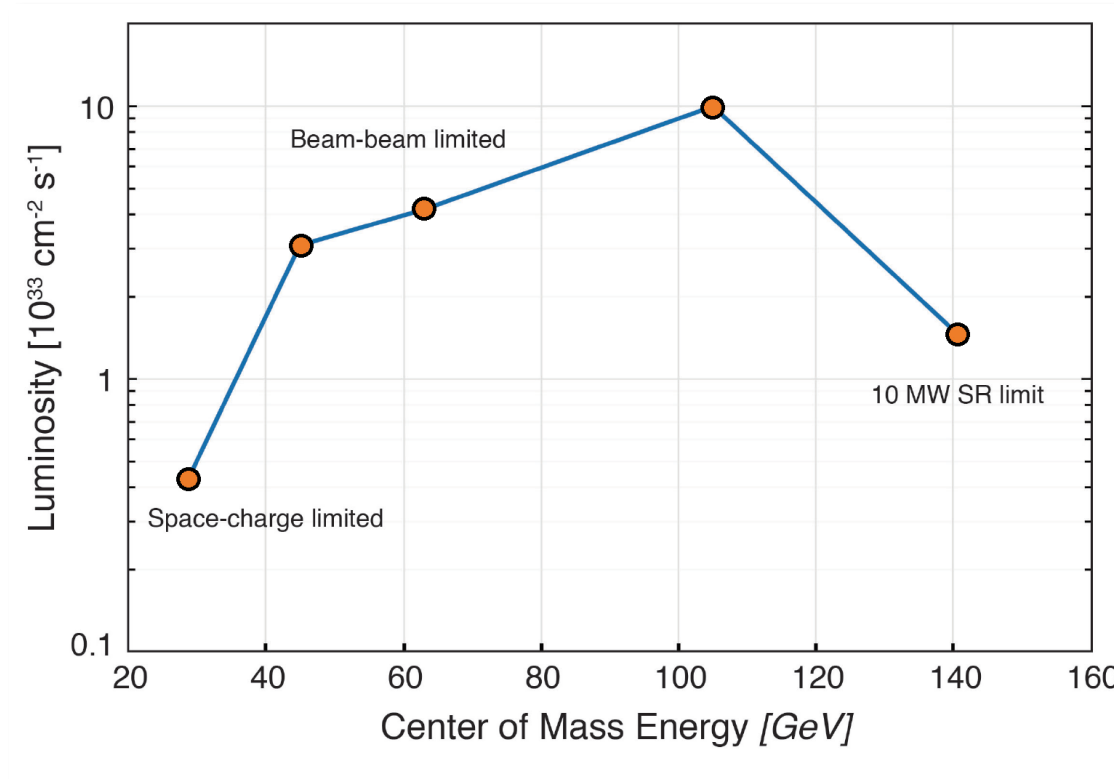

- Parameter and IR **optimization at 105 GeV** center-of-mass energy
- Optimization yields $10^{34} \text{ cm}^{-2} \text{ sec}^{-1}$ luminosity at 105 GeV

Dynamic Aperture

- Luminosity requires small beam size at collision point, implies large divergence

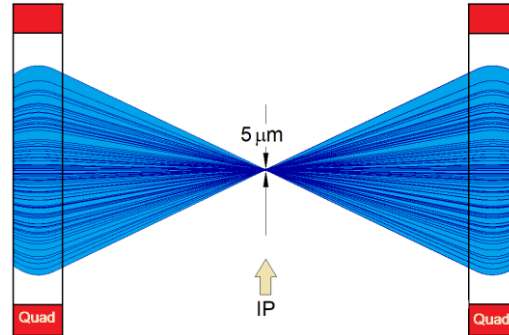

- Particles with slightly different beam energies experience weaker/stronger focusing (“chromaticity”) → beam optics distortions: must be corrected to store a beam
- Need nonlinear sextupole magnets to compensate
- Contributions from IR where beam size is large and final focus quadrupoles a strong dominate → strong nonlinear sextupoles
- Strong sextupoles limit betatron oscillations (@beam size)
- As the electrons beam size generated by from synchrotron radiation effects we must
 - limit the focusing (affects beam size at IP and luminosity)
 - Optimize distribution of nonlinear sextupole fields around the machine to keep the beam stable.
 - → sophisticated linear and nonlinear lattice design

Beam-Beam Interactions & Crossing Angle

- We fill 1160 bunches for collisions, and we need to make sure that beams collide only at the IP → need to collide under a crossing angle of 25 mrad
- The crossing angle would greatly reduce luminosity because the bunch length contributes to the cross section

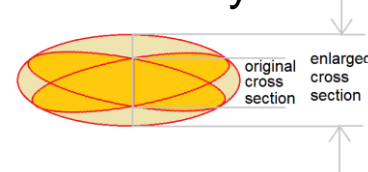

- We need crab rf deflectors to compensate for this effect, → beam directions are restored to parallel
- This complicates the beam-beam interaction, especially for hadrons: more sources of hadron emittance blow-up
- Electrons are more resilient to transient distortions while hadron emittance blow-up is irreversible (without strong hadron cooling)

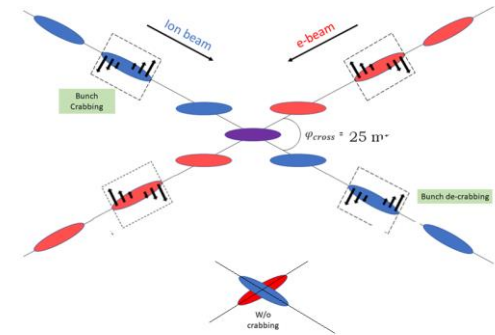

Once hadron beam size is blown up, electron will re-shrink and the blow-up will be accelerated

- Fluctuating beam-beam offset will cause rapid emittance growth (increase of beam size), many sources, including phase noise of crab cavities → extremely small tolerances

Interaction Region

- 25 mrad crossing angle
- Superconducting final focus magnets
- Crab cavities
- Spin rotators
- Large acceptance for forward scattered hadrons

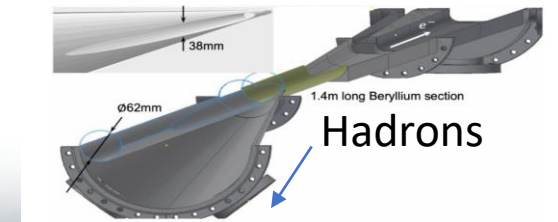
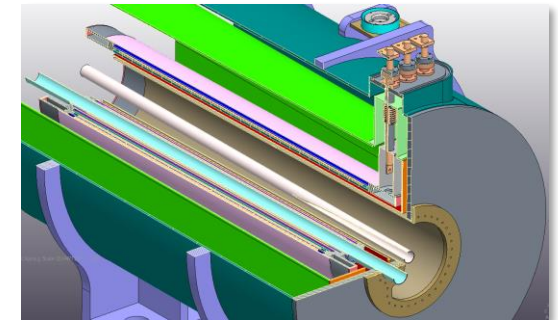
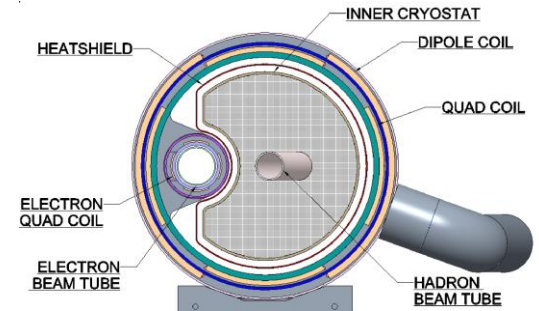
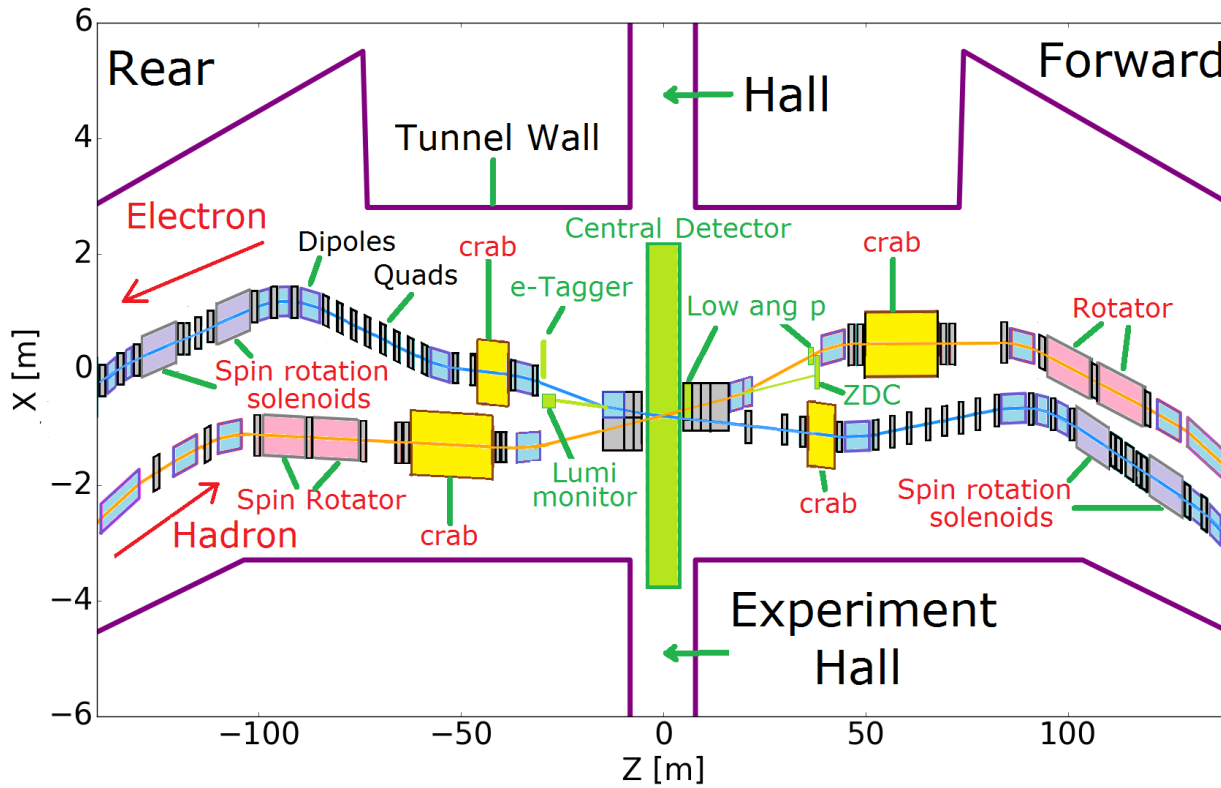

IR-6

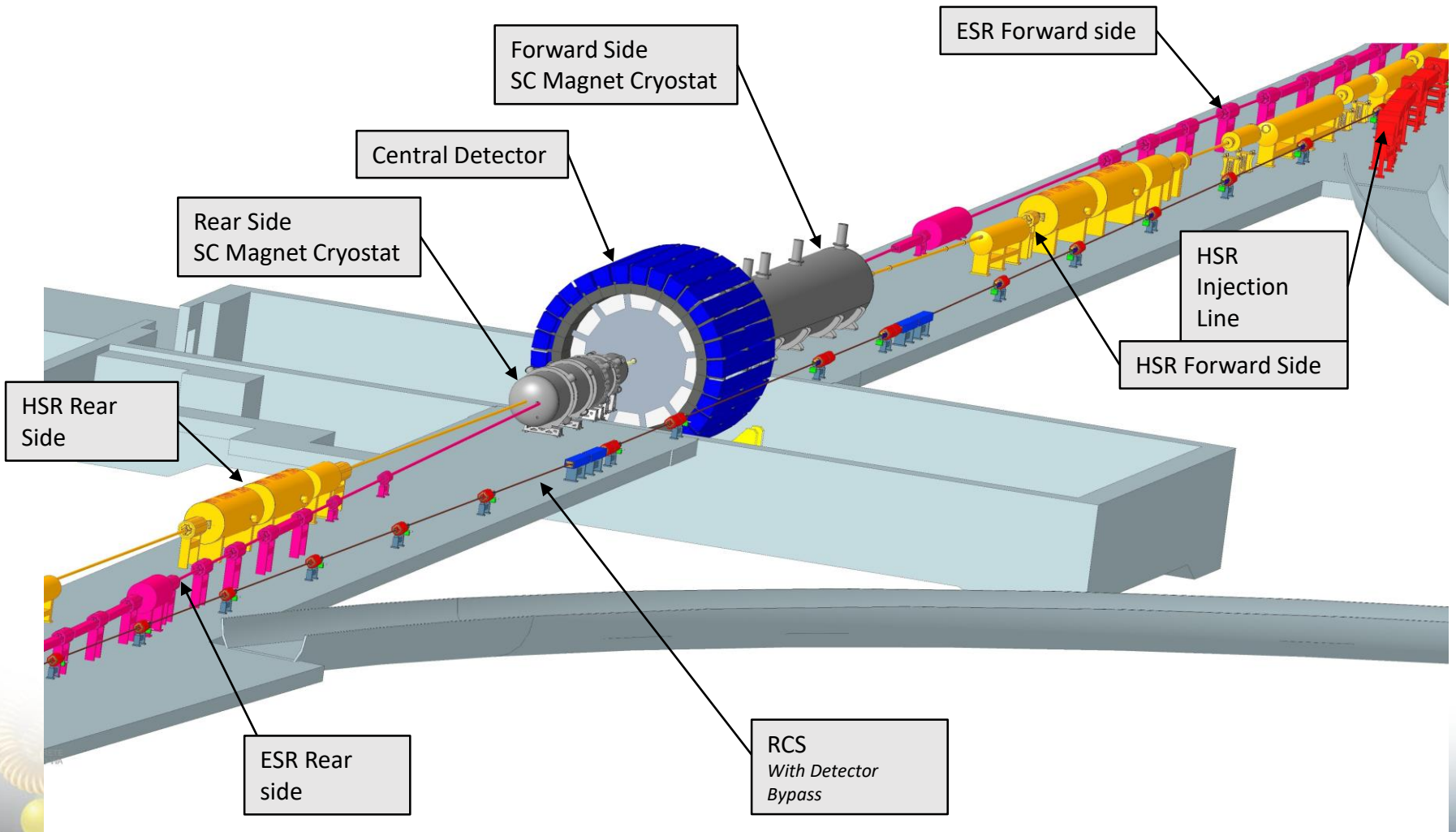

ESR polarization

- In ESR, synchrotron radiation helps building up polarization slowly
- but there are counteracting effects that destroy polarization
- Equilibrium polarization is only 30%-60% in ESR, but need we 70-80%
- Buildup would work only for upward direction
- Electron polarization electrons created by polarized source
- and preserved during acceleration in the RCS (quite tricky)
- In ESR, long list of effects that destroy injected polarization
- need
 - Extremely careful orbit control (microns)
 - Extremely careful compensation of cross coupling between transverse planes
 - Very careful choice of tunes hor, vert, long, and spin
 - Careful compensation of detector solenoid by rotated quadrupoles

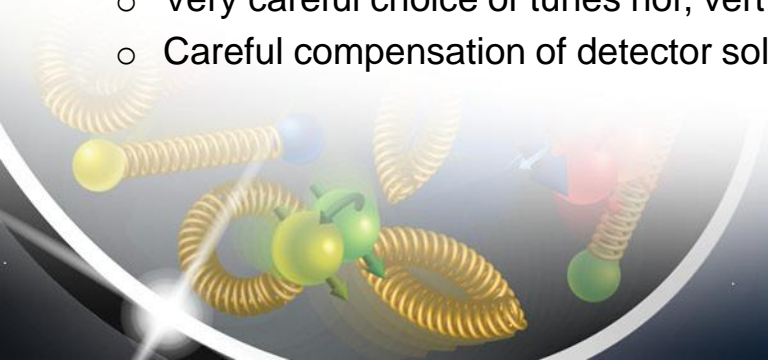

Strong Hadron Cooling Design

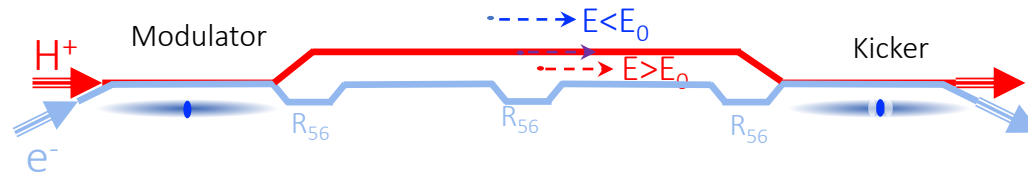

- Cooling Concept unch Coherent electron cooling with microbunching amplification
- Cooling process and amplification process supported by extensive simulations 1-D and 3-D simulations show slightly reduced cooling rates
- Challenging beam diagnostic tasks: beams have to remain synchronous across the cooling section on the micron level
- Pre-cooling at injection energy integrated into strong hadron cooling sharing many hardware components.

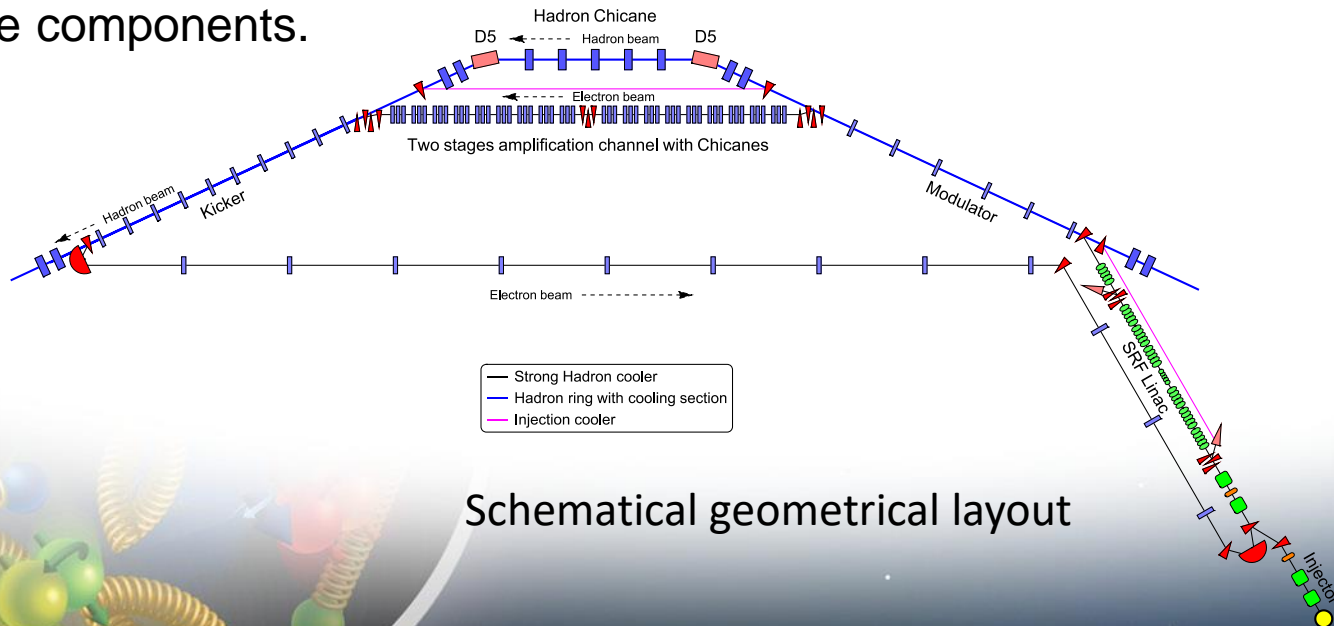

Schematical geometrical layout

Progress in Beam Dynamics

- **Beam-Beam interaction:** Comprehensive simulations and studies investigating numerous effects. Simulations confirm feasibility of EIC beam-beam performance parameters.
- **ESR dynamic aperture**
Now ensures sufficient dynamic aperture with 2 IRs @ 18GeV including magnet imperfections, sophisticated distribution of sextupole-magnets.
- **Collective effects and beam-vacuum vessel interaction** assessed and there are no issues with excessive heating by the beam or instabilities.
- **ESR Impedance** budget is complete with assessment of all vacuum hardware components.
- **Electron Beam Polarization:** Achieving required level of electron spin polarization up to 18 GeV with the vertical beam size required for stable beam-beam interaction resolved by “spin-matching” ESR beam optics.
- **Tolerance studies** for magnets, alignments, strength of correctors well underway.
- **Tolerances for crab cavity phase noise** worked out – very tight, also require strong direct feedback to suppress fundamental mode driven transverse instability. Requirement: Install RF power and controls on the accelerator tunnel berm, close to the cavities.

Accelerator R&D Overview

EIC R&D is prototyping of novel, challenging, or critical components to obtain confidence for final design and production of the components in industry or in-house

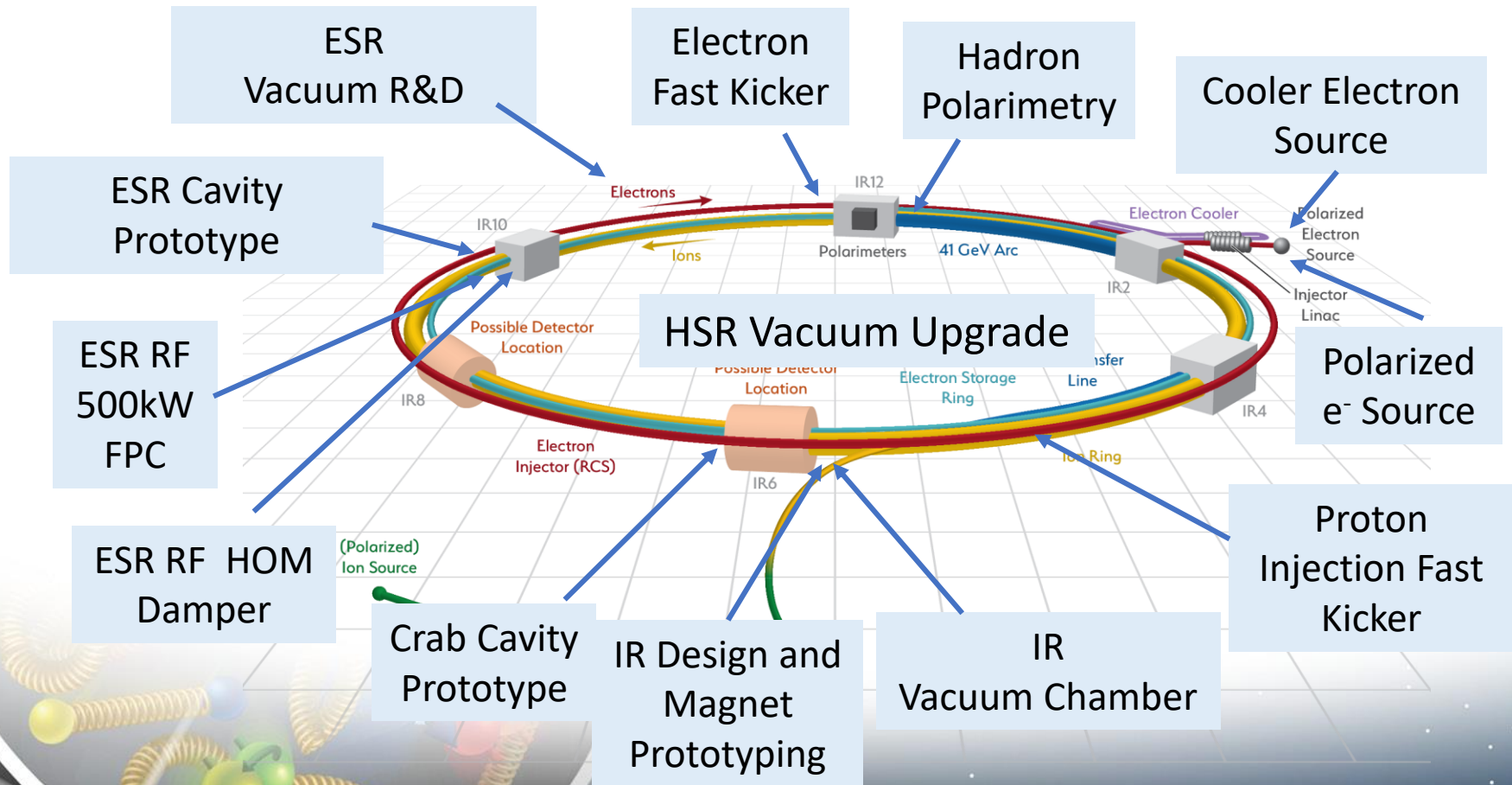

ESR Vacuum: Shielded Bellows

Prototype Design

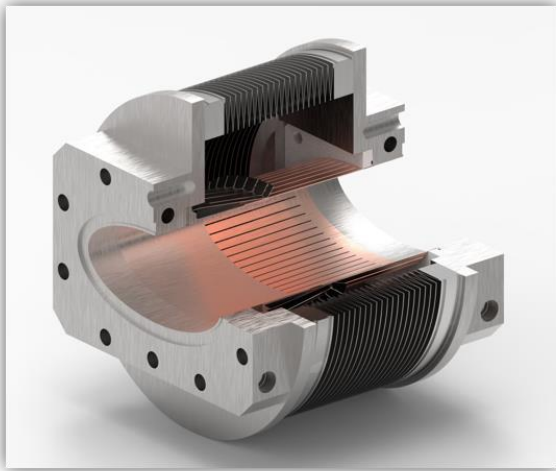

Manufactured parts for a prototype

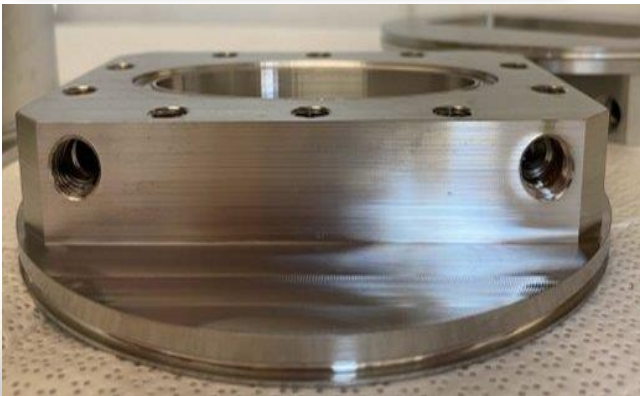
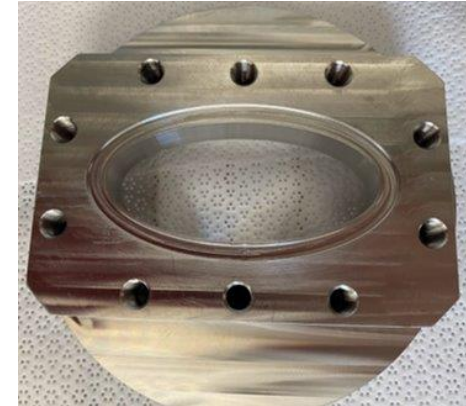
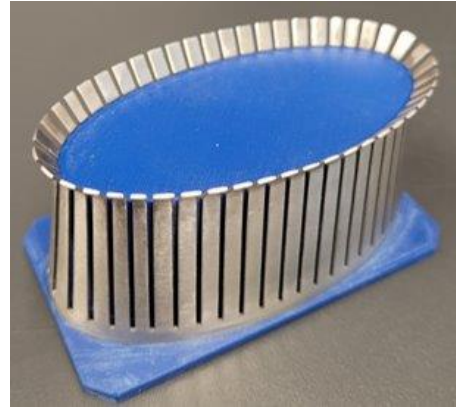

Plans for lifetime testing



HSR Vacuum Cu/aC Coated Beam Screen

WBS 6.05.04, 6.02.03.04

HSR vacuum beam screen design change from passively cooled conduction cooling to actively cooled.

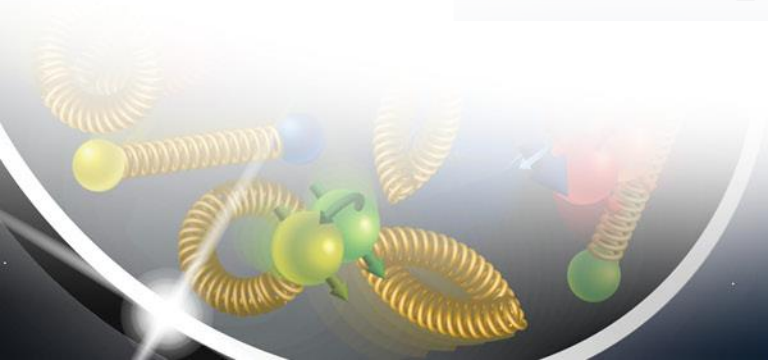
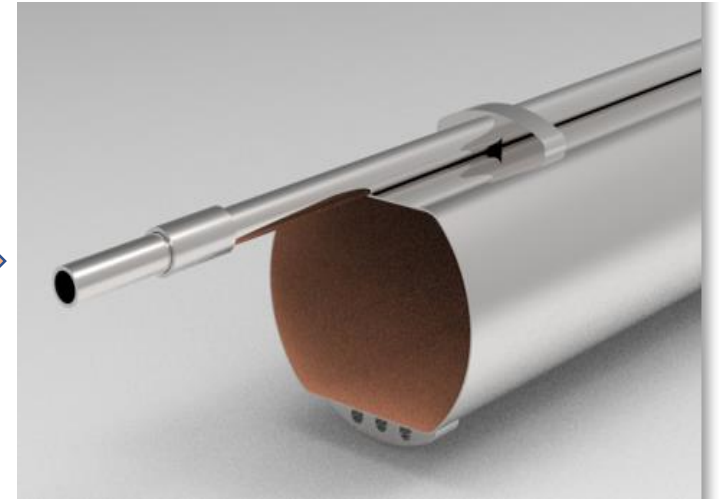
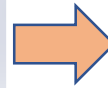
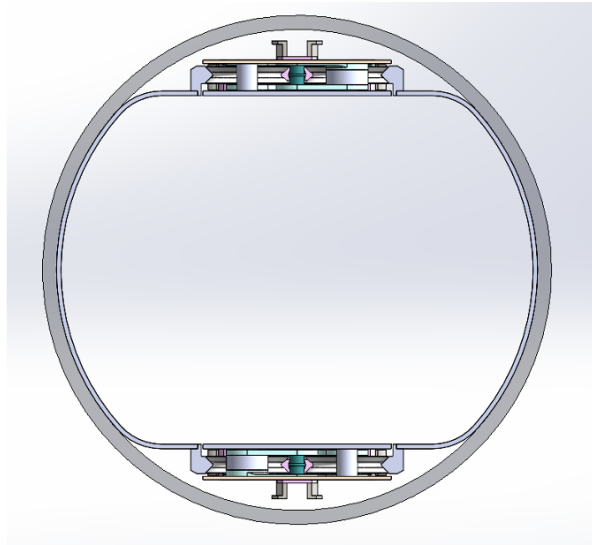

197 MHz Crab Cavity Status WBS 6.08.02.01

- 197 MHz HSR crab cavity is one of the cavities that will be prototyped first
- Bare cavity rf design is complete
 - Including HOM damping, FPC design
 - Two possible HOM damping schemes: Waveguide loaded and coaxial couplers
 - Waiting for final rf multipole specifications and are not considered in the current design
- Stress analysis is near completion
- Preliminary fabrication plan is completed

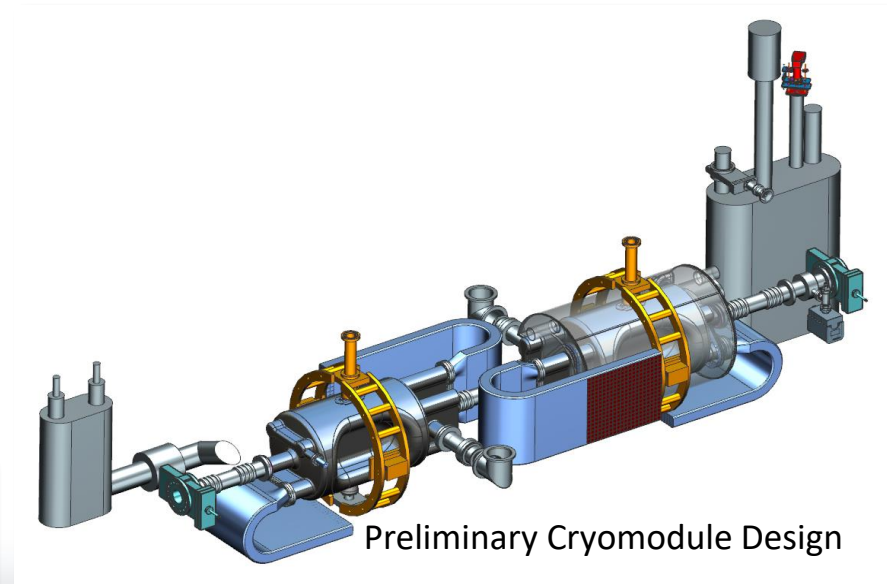
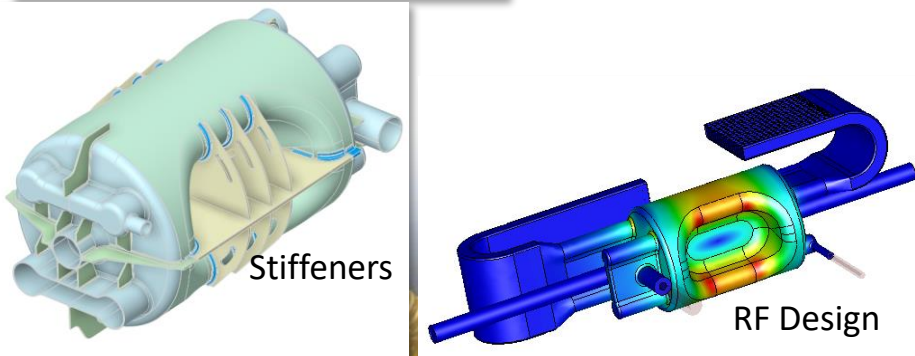
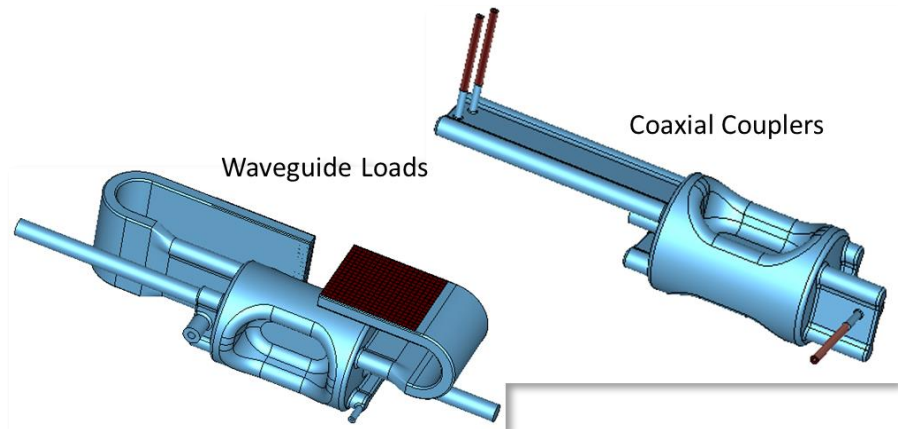

R&D on High power FPC Status

- A high power (CW 500 kW standing wave) alumina window FPC was designed for EIC ESR SRF cavity.
- The design was reviewed by an international technical review committee in June 2021.
- The review committee stated their “support moving forward with this design into prototype stage”.
- Detailed engineering design for window and vacuum side has been finalized and in the process of prototyping.
- FPC airside is almost finalized and getting ready to purchase materials for fabrication.

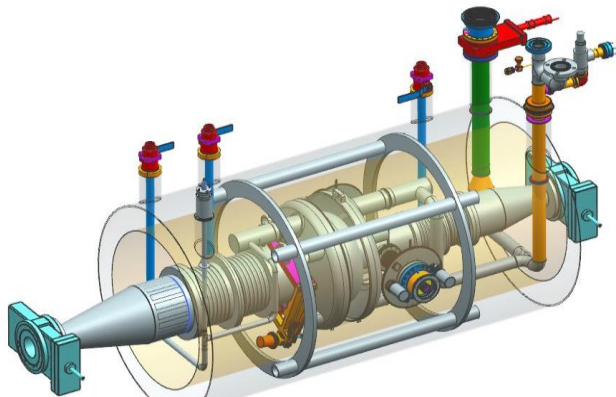

Preliminary Cryomodule Design

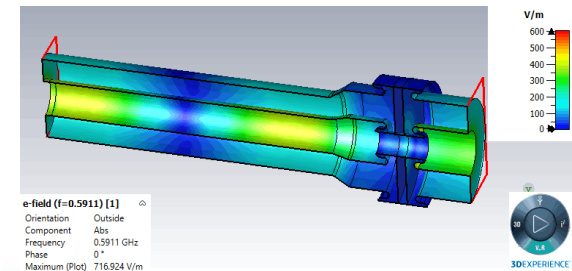
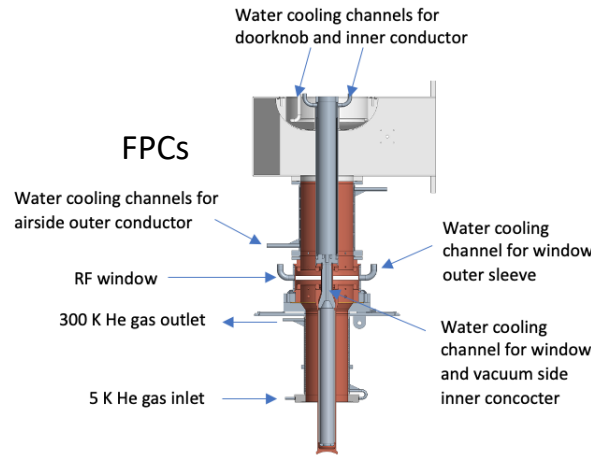

Superconducting IR Magnets

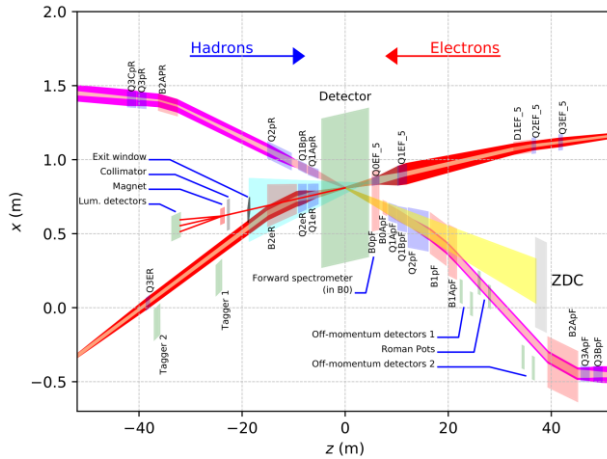

Forward site s.c. magnet integration

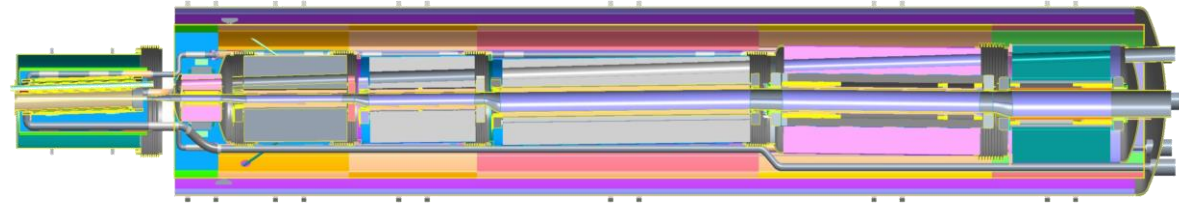

Multiple function spectrometer magnet at the forward hadron side

Rear Side Integration / Beampipe

Separate cold masses - helium vessels
 Separate circular cryostats with decreasing OD's toward IP

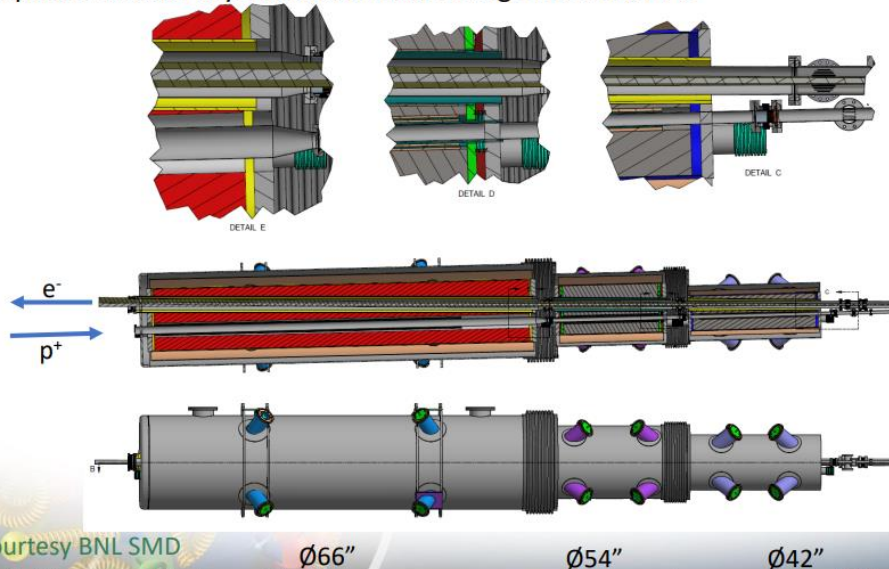

IP
 X

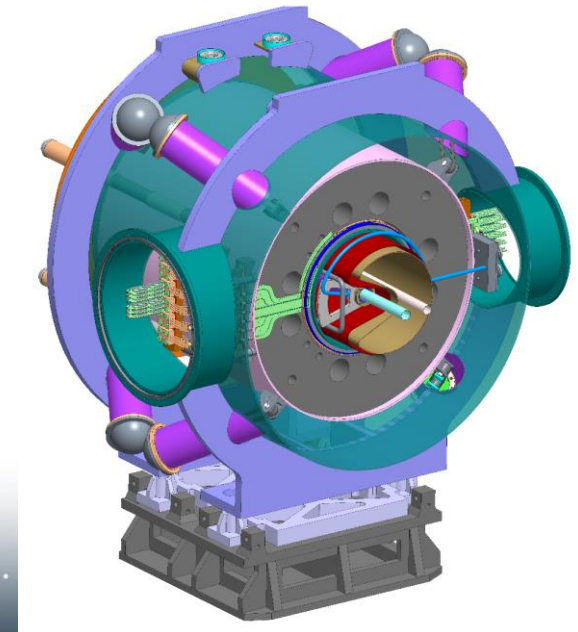

EIC Schedule

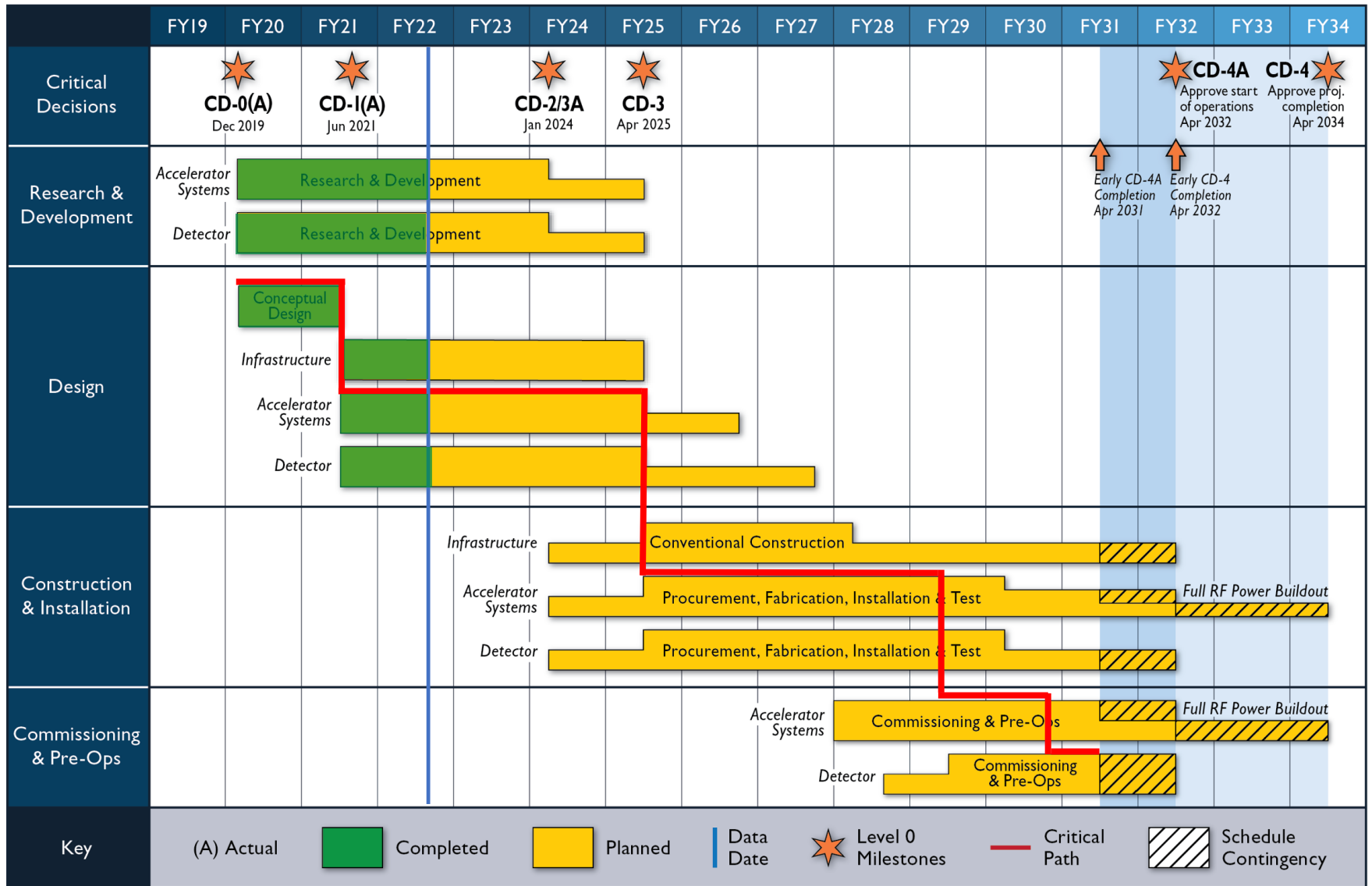

Worldwide Interest in EIC

The EIC Users Group:
<https://eicug.github.io/>

Formed 2016 –

- 1331 collaborators,
- 36 countries,
- 266 institutions as of June 07, 2022.

Strong and Growing
International Participation.



EICUG membership @ time of
EICUG Meetings

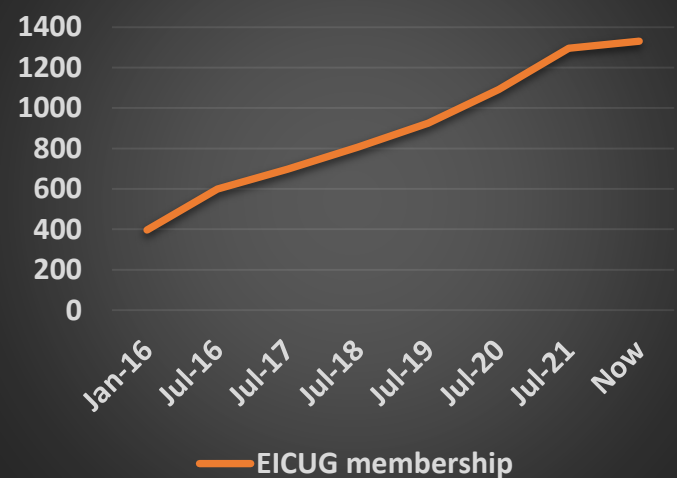

Annual EICUG meeting

2016 UC Berkeley, CA
2016 Argonne, IL
2017 Trieste, Italy
2018 Washington, DC
2019 Paris, France
2020 Miami, FL
2021 VUU, VA & UCR, CA
2022 Stony Brook U, NY
2023 Warsaw, Poland

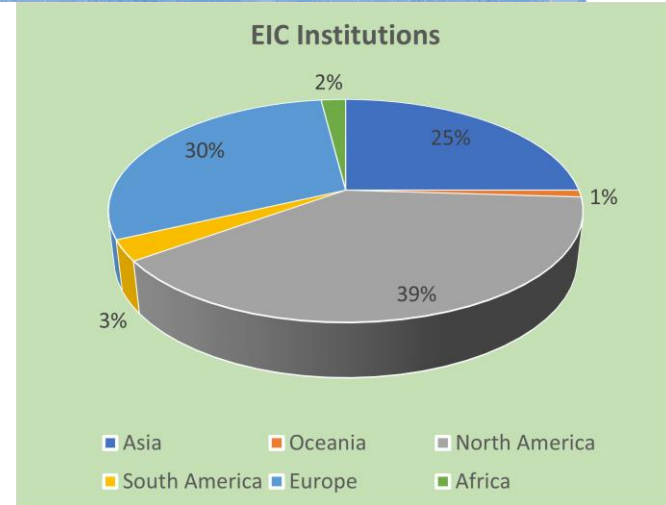

Summary

- The EIC is one of the most complex colliders because of several performance requirements that all are require reaching at or beyond state of the art
- The challenging accelerator science questions of the EIC have all been addressed and remaining open question will only have a minor impact of EIC performance
- Accelerator global design is close to be completed and designs are now stable to serve a base for engineering design
- R&D made good progress in all areas that did not require large material expenses
- Engineering of components is still in an early stage
- The project will increase collaboration with other DOE laboratories to deliver the EIC scope.
- Scientists and Engineers contributing to EIC are developing into a strong competent team that will deliver the EIC project.

Evolution of Accelerator Design

The time since CD-1 and the last OPA review with limited PED funds was well used to advance and mature the accelerator lattices and resolve corresponding design issues. Designs are now very robust and provide a solid base for the engineering design of accelerator hardware components.

Updated design and R&D plans posted on review site; **accelerator lattices now stable**

- **Electron Injection** Moved from IR-2 to IR-12
- **Electron injection into ESR** modified: Eliminated slow bumps (because residuals affect the entire fill every second). Now fast kickers are stronger (1 mrad). We are also looking into nonlinear injection (for example a sextupole in the injection trajectory).
- **Strong Hadron Cooling ERL** moved from ring outside to ring inside
- **The bypass for low energy hadron storage** was moved from sector 2-12 to sector 12-10, now use 4 sextants from the yellow ring and two sextants from the blue ring for the HSR
- **Hadron straight sections:** beam transport uses now normal conducting dipoles instead of superconducting dipoles
- **ESR accelerator lattice design** is (nearly) complete
- **RCS accelerator design** complete
- **Interaction region further matured**, lattice stable, synchrotron radiation masking laid out, collimation in progress
- Many details on **HSR lattice** resolved ...

Polarization

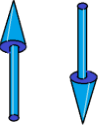

- Spin: fundamental parameter of elementary particles associated with a magnetic moment
- Polarization of beam means most of spins are oriented in the same direction
- EIC physics requires collisions of highly polarized hadron and electron beam with polarization in two opposite directions
- In the arcs, the polarization processes around the direction of the bending field (vertical)
- In the IP, polarization needs to be in the direction of the beam motion
- ➔ Need spin rotator magnets to turn polarization into longitudinal direction(s)
- For hadrons this was already accomplished in RHIC, requires only minor improvements

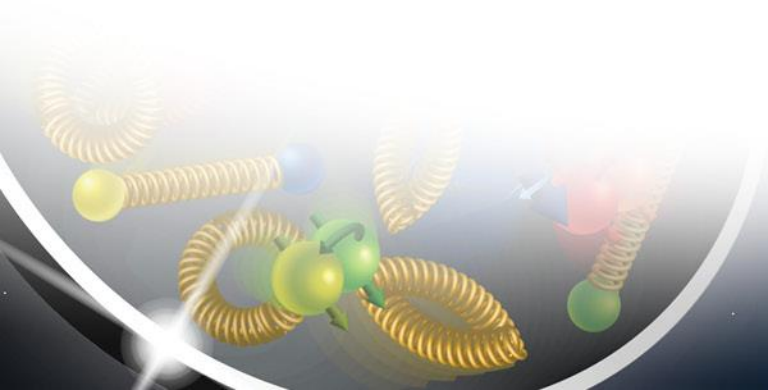

Large Detector Acceptance & Low Backgrounds

- Large accelerator component-free space around IP: -4m to + 5.5 m → challenge for beam focusing
- Large aperture of hadron magnets on the forward side to provide acceptance for scattered low- p_T particles to be detected by roman plots along the outgoing hadron beam-pipe
- Neutron spectrometer in the forward hadron direction (need strong hadron orbit bend)
- Very good vacuum <1ntorr despite presence of SR around the IR to prevent scattering of hadrons in the IR (use NEG, ion, TSP, turbo pumping)
- Straight electron orbit, synchrotron masking and Au coating of Be detector beam prevent/mitigate direct hits

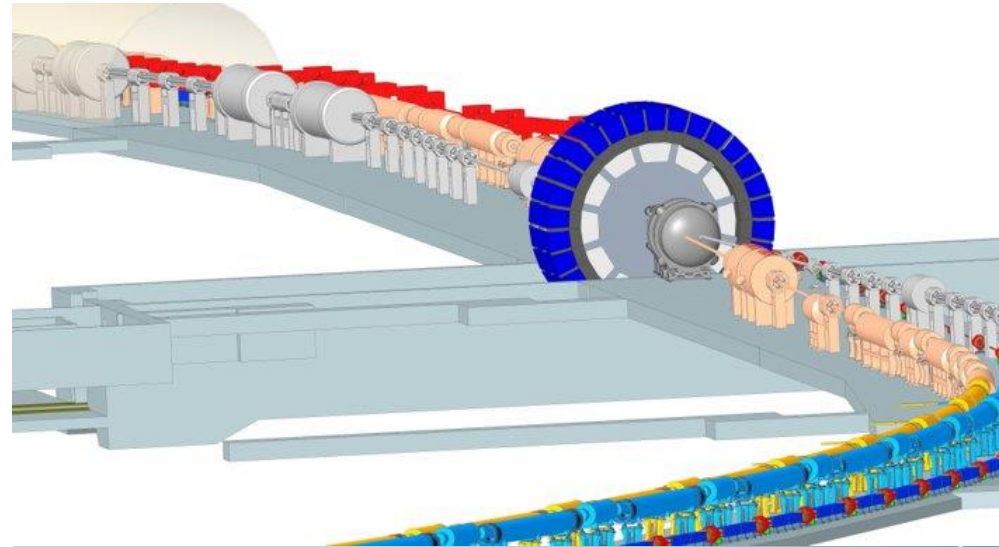
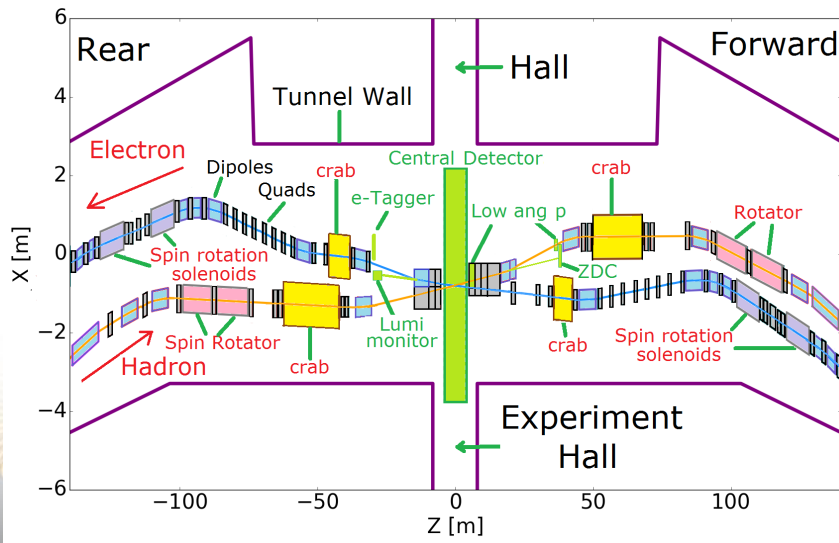

Superconducting IR Magnets

Rear Side Integration / Beampipe

Separate cold masses - helium vessels

Separate circular cryostats with decreasing OD's toward IP

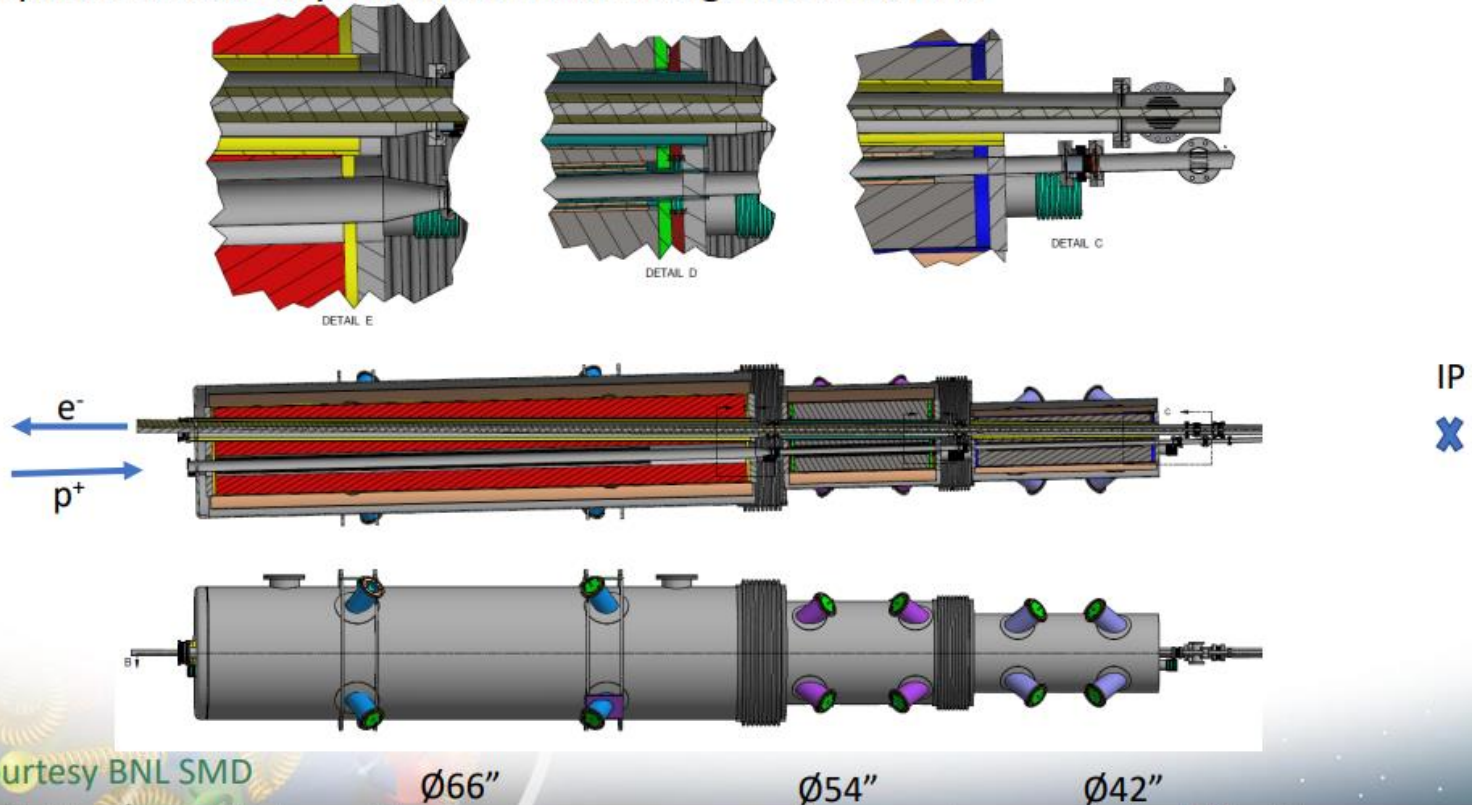

Courtesy BNL SMD

Accelerator R&D

6.02.03	Accelerator Systems R&D	Q. Wu
6.02.03.01	Accelerator Systems R&D Management	Q. Wu
6.02.03.02	Polarized Electron Source R&D	J. Skaritka
6.02.03.03	IR Design and Magnet Prototyping	H. Witte
6.02.03.04	Hadron Ring Vacuum Chamber Upgrade	S. Verdu Andres
6.02.03.05	Proton & Electron Fast Kickers	J. Sandberg
6.02.03.06	Vacuum Systems Development	C. Hetzel
6.02.03.07	Cooling R&D	E. Wang
6.02.03.08	Hadron Polarimetry	O. Eyser

Note: RF R&D captured by 6.08

- Polarized Electron source prototype comfortably achieved EIC design parameters.
- IR Magnet Prototyping design now based on 2K Iq He cooling.
- Vacuum Chamber upgrade is now based on actively cooled beam screen.
- Good progress and refinement of HSR fast kicker design.
- ESR Vacuum design: simplified vacuum chamber profile to ensure manufacturability.

Luminosity Optimization

$$\text{Luminosity} = f_{\text{rev}} \cdot n_b \cdot N_{\text{eb}} \cdot N_{\text{hb}} / (4\pi \cdot \sigma_x \cdot \sigma_y)$$

$$= I_h \cdot I_e / (4\pi \cdot e^2 \cdot f_{\text{rev}} \cdot n_b \cdot \sigma_x \cdot \sigma_y) \quad \sigma_{y,y} = \sqrt{\varepsilon_{x,y} \beta_{x,y}}$$



Beam currents limited (SR, Cryo load)
always make s large as possible

Minimize number of bunches to the
extent beam dynamics allows

However, stronger bunches means strong beam-beam interaction

Beam-beam interaction strength $\xi_{h,e} \sim N_{h,e} / (\varepsilon_{h,e} \cdot (\sigma_x + \sigma_y))$

Thus, with high $N_{h,e}$ thus small n_b , need to increase emittances,
and the luminosity is unchanged

What is the advantage?

**Emittance can be relatively large and that reduces the demand on
keeping it small by strong hadron, which is more than desirable**



Matching Dipole

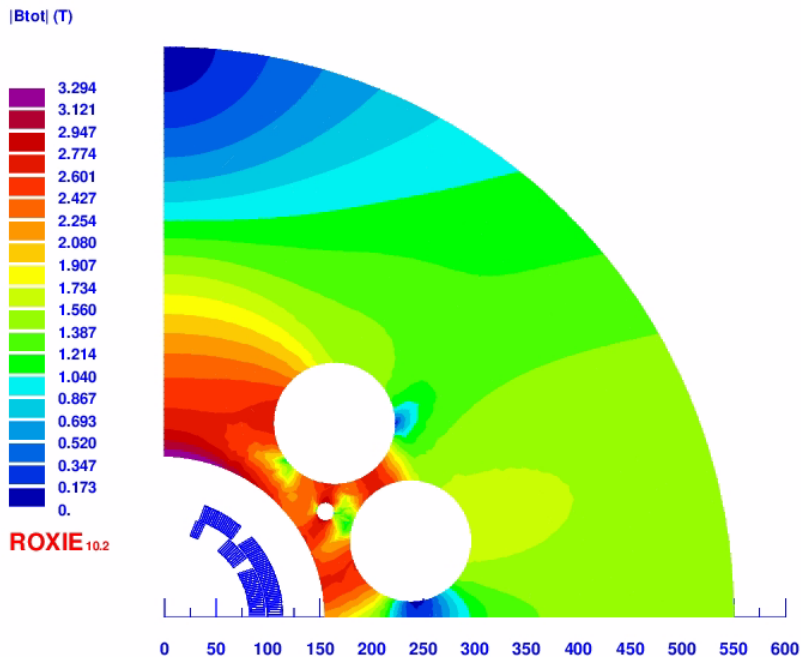

Harmonics for different excitations

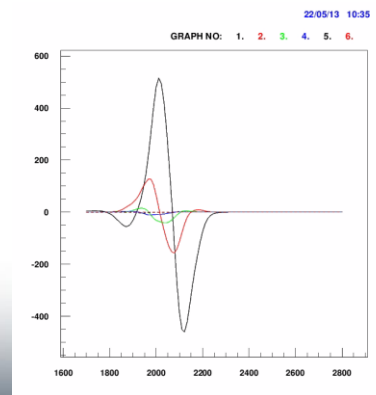
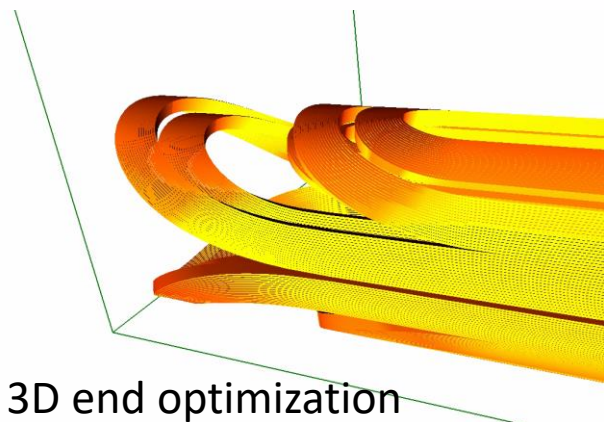
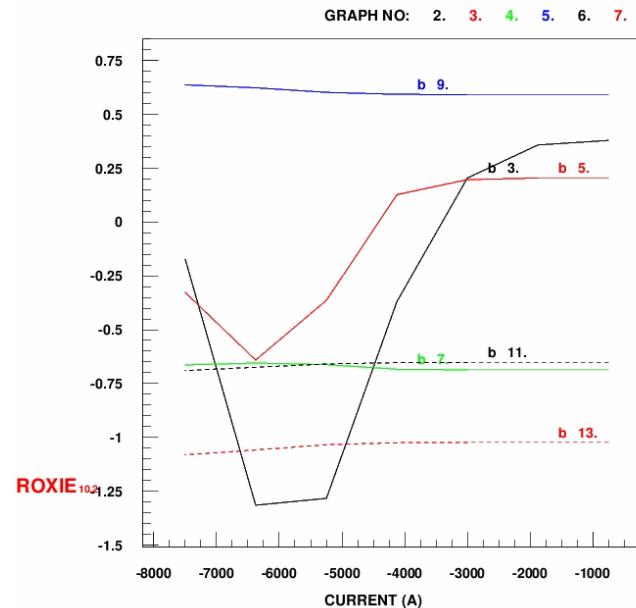

Harmonics in ends

SC IR Magnet R&D

EIC Q2pF 15mm cable, 2K - or=600 mm, NO tie rods 7.5kA, hole366.8mm 22/04/01 17:33

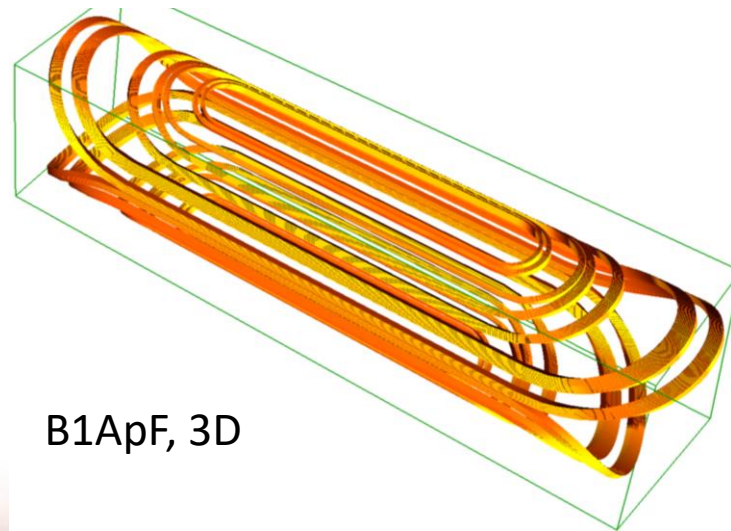
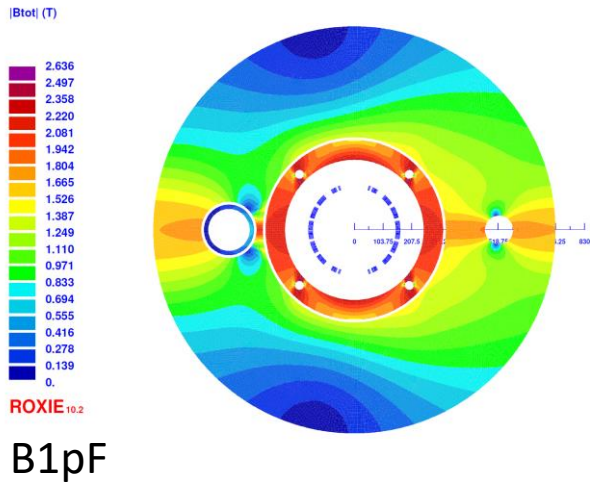
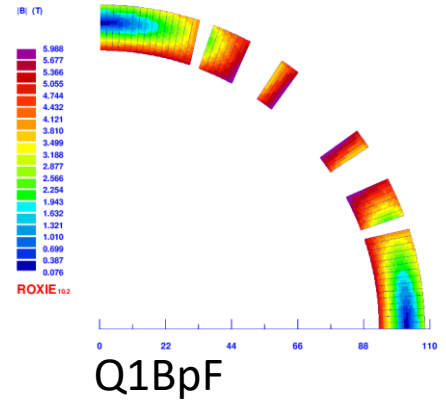
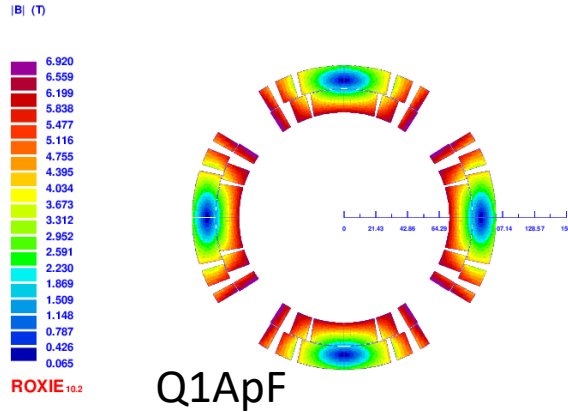
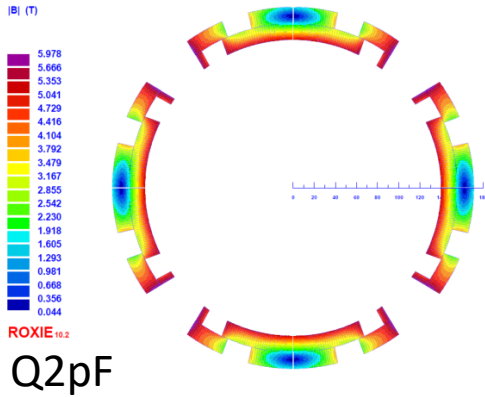

B1ApF, end harmonic optimization

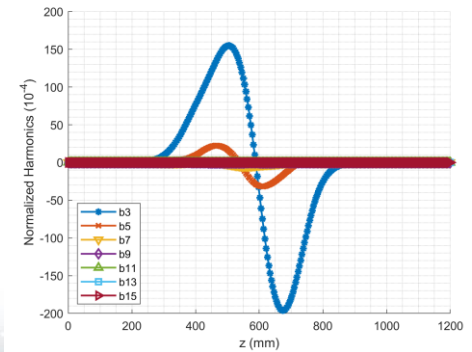

Progress in PED and R&D

- **ESR and RCS Magnets** (WBS 6.04.02, 6.04.03, 6.03.02.01,6.03.02.02):
 - Value engineering efforts: Single turn coils changed to multi-turn coils (change request pending), RCS dipoles split into two (cost saving and manufacturing simplification)
 - Specifications for RFI developed, RFI published, 16 of 24 vendors responded positively.
- **ESR Vacuum** (WBS 6.04.05)
 - Vacuum chamber profile optimized for better manufacturability (extruded → attached cooling chamber)
 - Shielded bellows: Fabrication of prototype in progress.
 - Novel self-supporting NEG strip design, greatly simplifies installation and activation

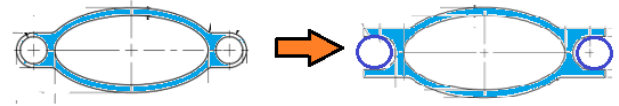

IR-10

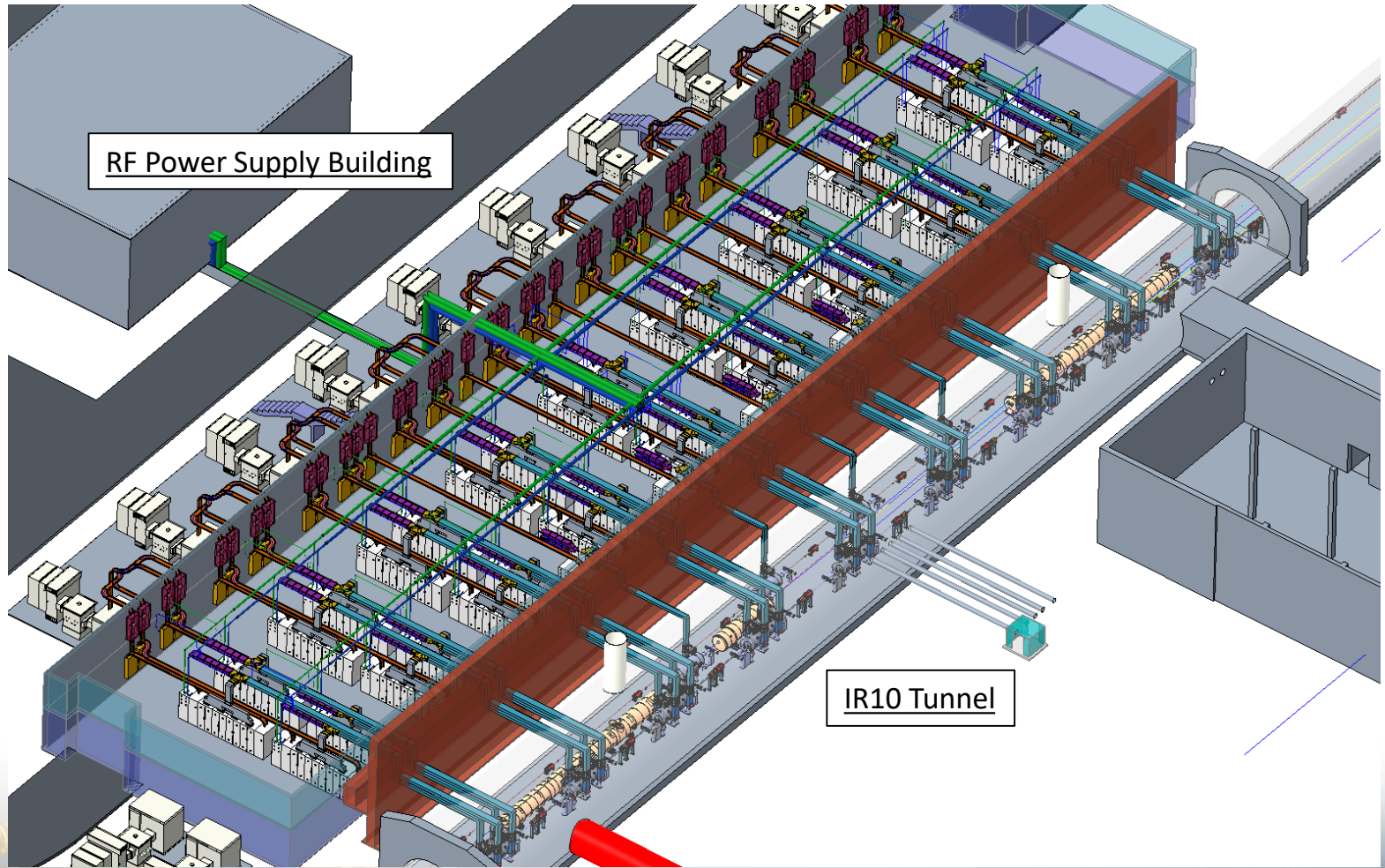

IR-12

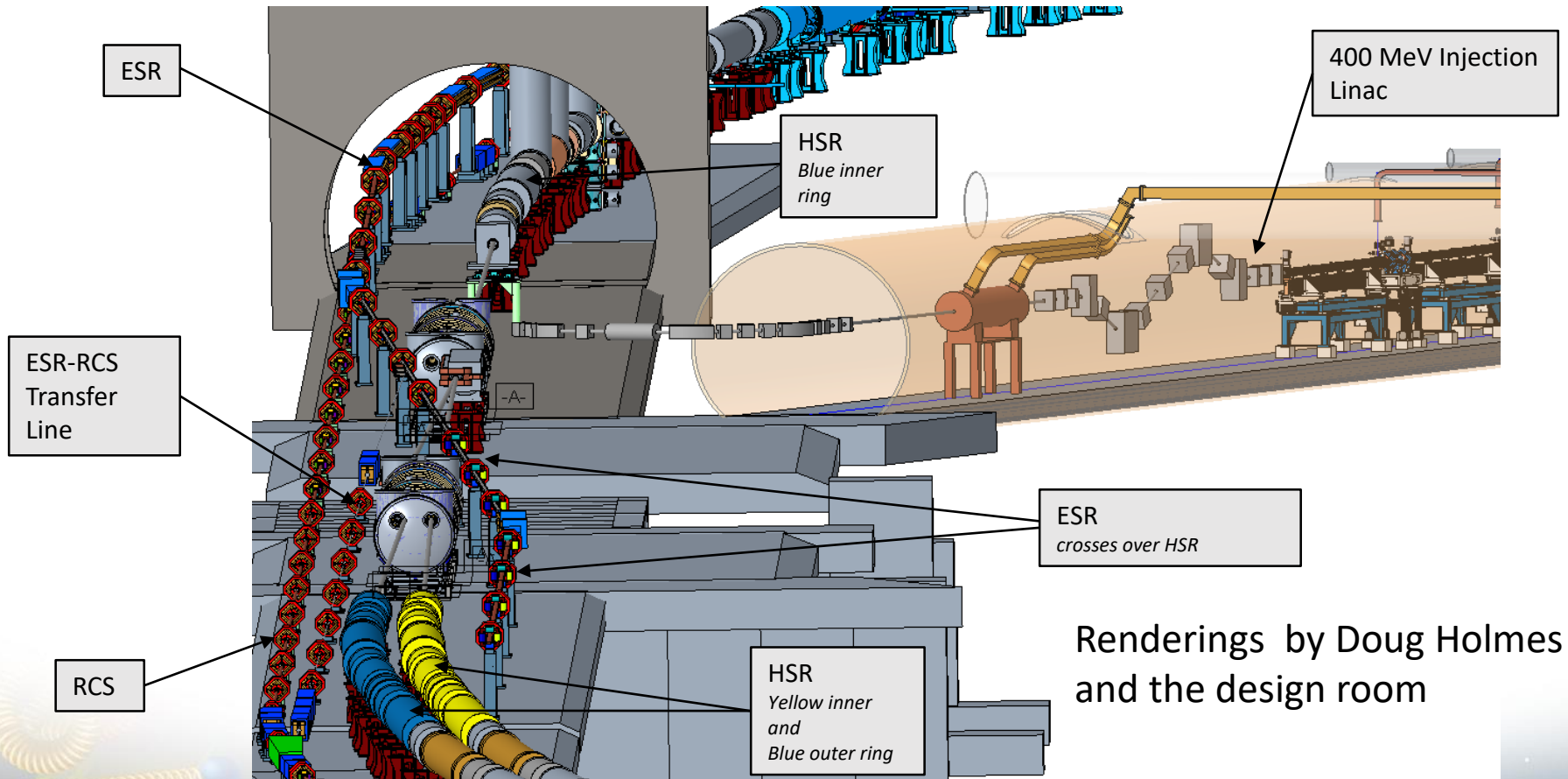

Renderings by Doug Holmes and the design room

IR-2

Renderings by Doug Holmes and the design room

