

# CONSIDERATIONS FOR BEAMSTRAHLUNG DUMP INTEGRATION

## FCC-ee Underground Structure Overview

## FCC-ee Machine tunnel Layout

## FCC-ee main and booster rings Layout

## FCC Underground structure point A

- *FCC Experiment underground structure*
- *FCC-ee wide machine tunnel (beamstrahlung dump integration)*

# FCC-ee Underground Structure Overview

Only schematic, and not to scale.

- █ FCC Tunnels
- █ Experimental points
- █ Access points
- █ Service caverns
- █ Connection tunnels
- █ Electrical alcoves
- █ Klystron galleries
- █ Tunnel widening
- █ Cryo cavern
- █ LHC

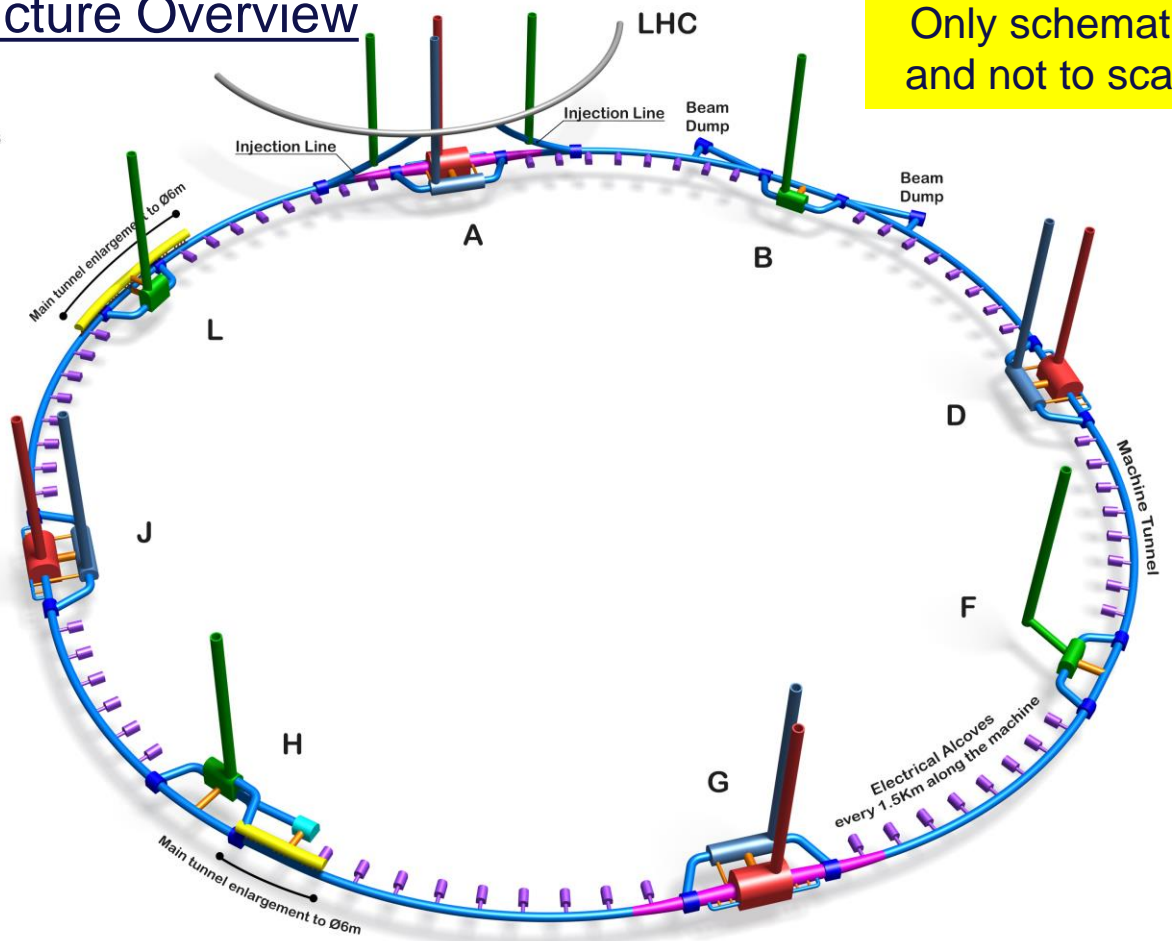

Courtesy A. Navascues Cornago

# Integration of FCC-ee machine elements (regular arc)

Machine tunnel 5.5m in diameter

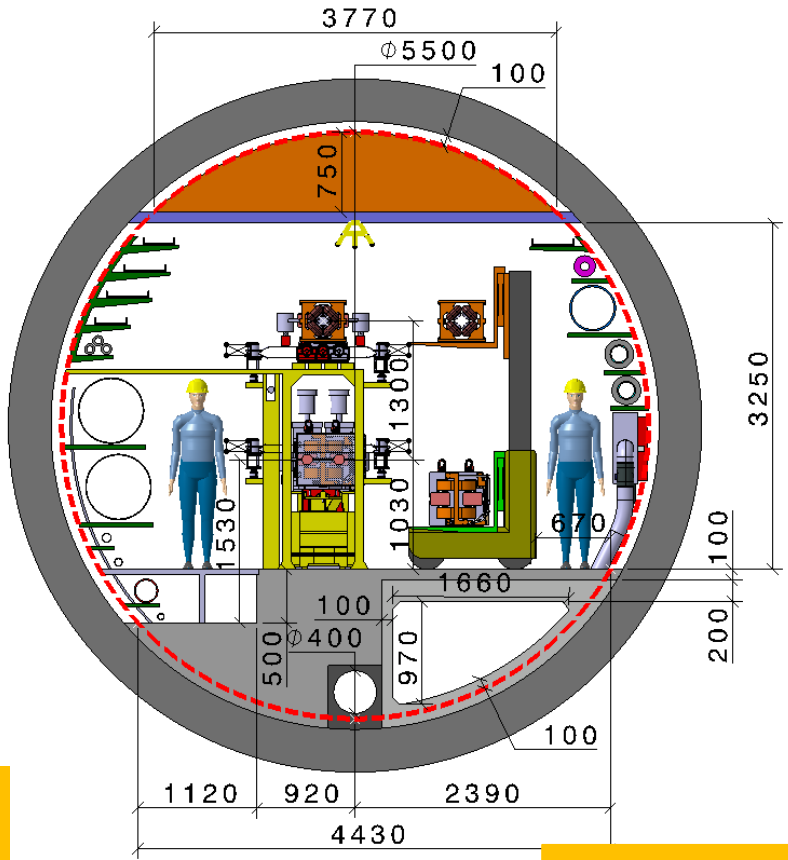
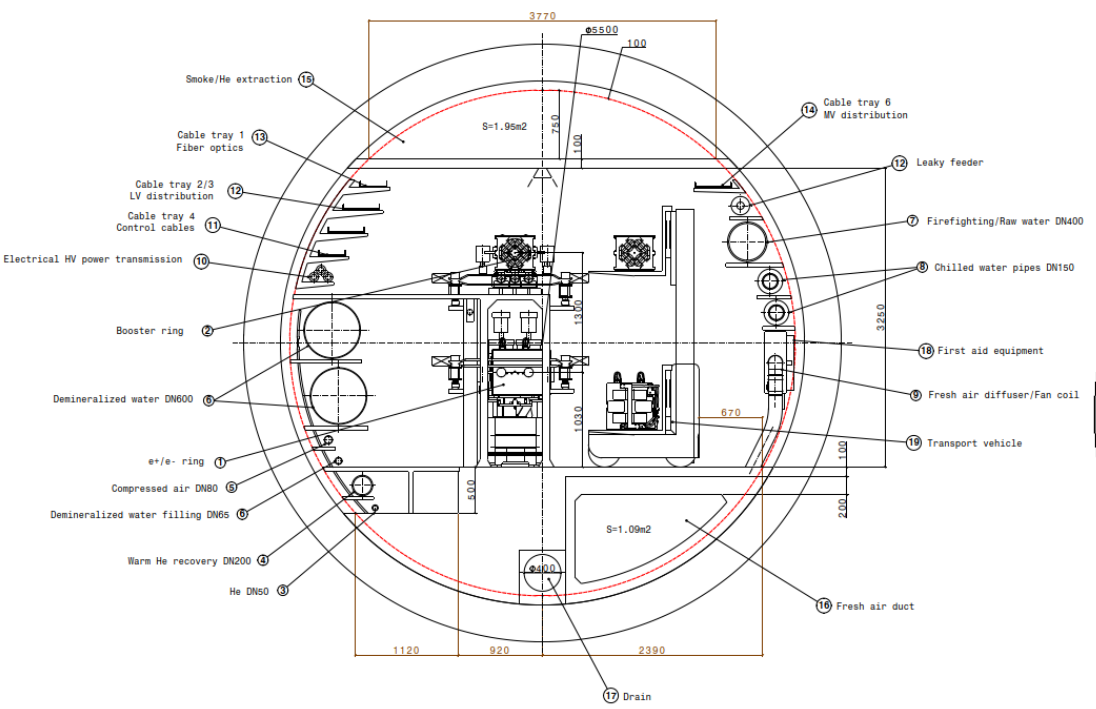

Main ring below of booster ring  
 Main ring and booster ring 1.3 m distant  
 Water distribution changed

Collider Center



# FCC-ee main and booster rings Layout

Two different trajectories for booster ring

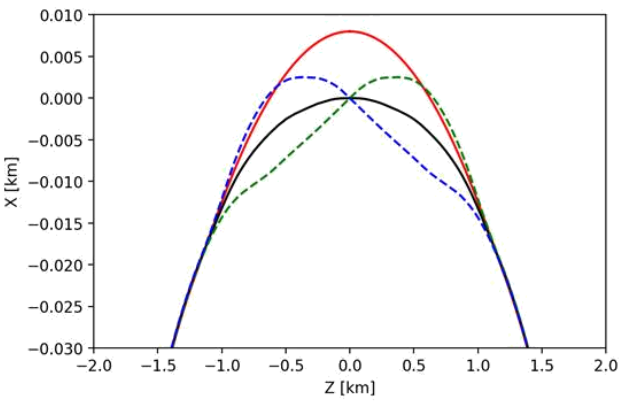
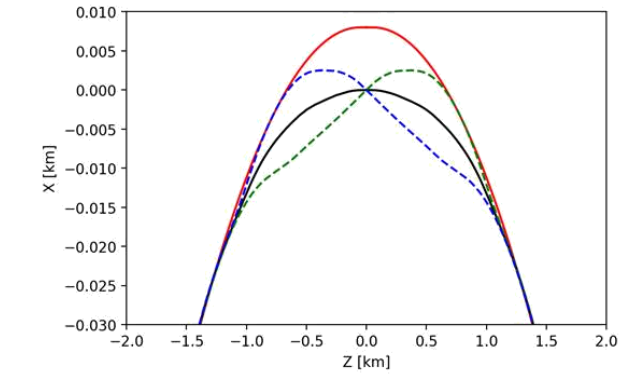

- E- ring
- E+ ring
- Booster ring
- - Beamstrahlung Dump

Courtesy K. Oide/ A. Chance

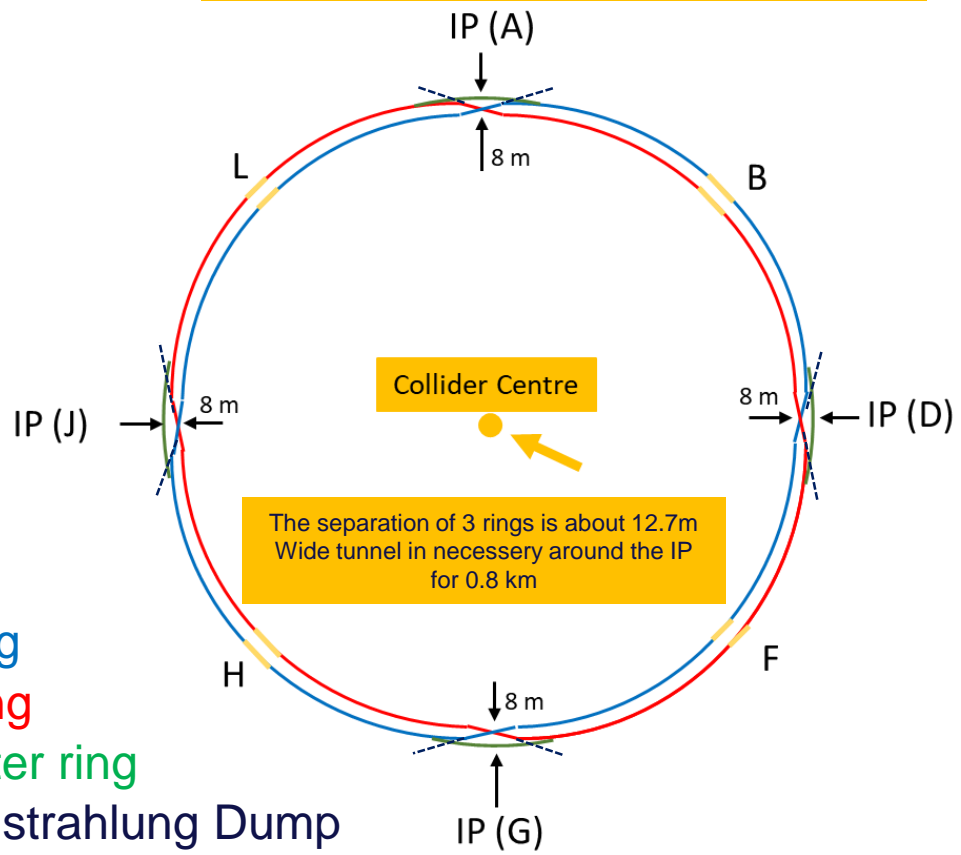

# FCC Experiment Underground Structure point A

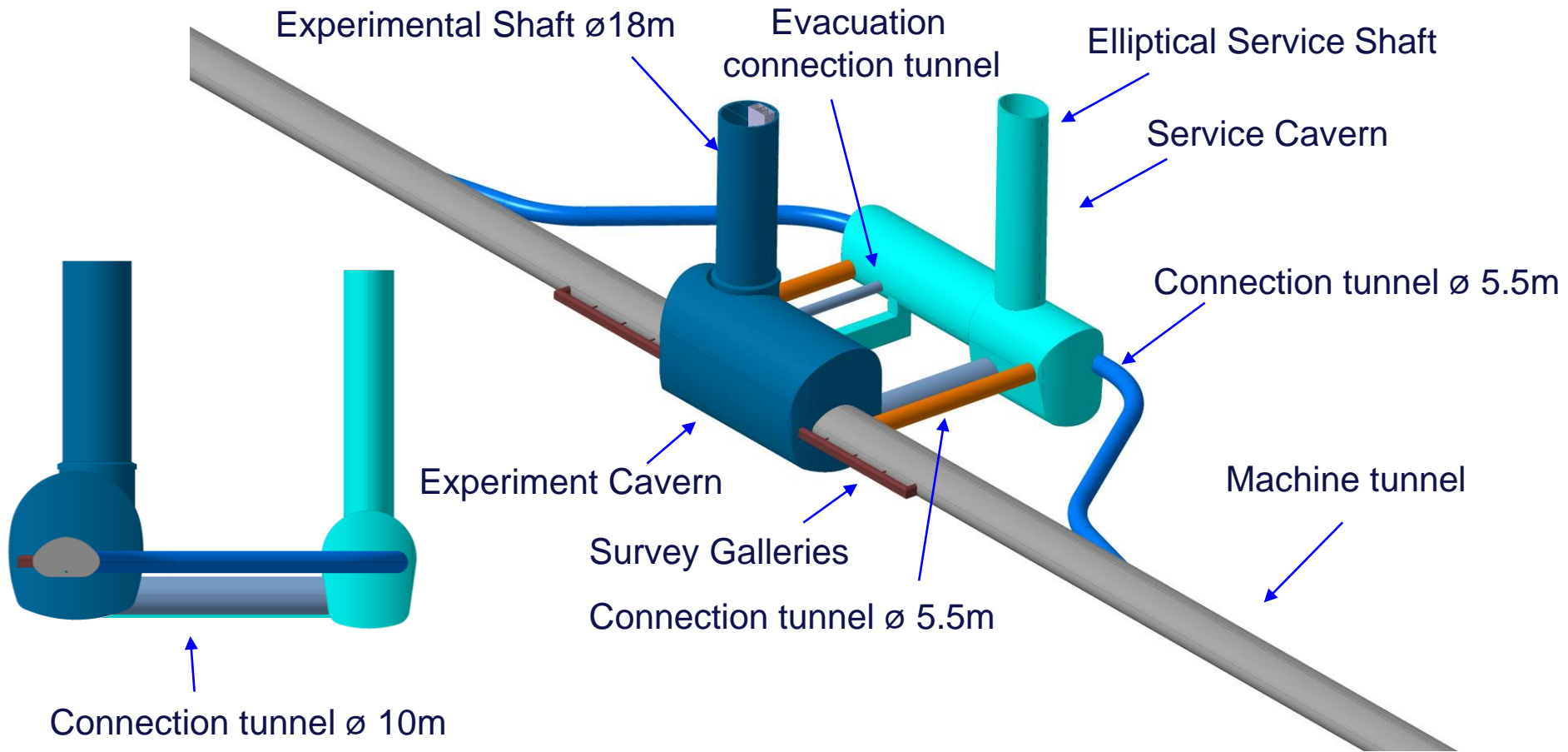

# FCC Experiment Underground Structure point A

Experimental Shaft  $\varnothing 18\text{m}$

Elliptical Service Shaft 18x12

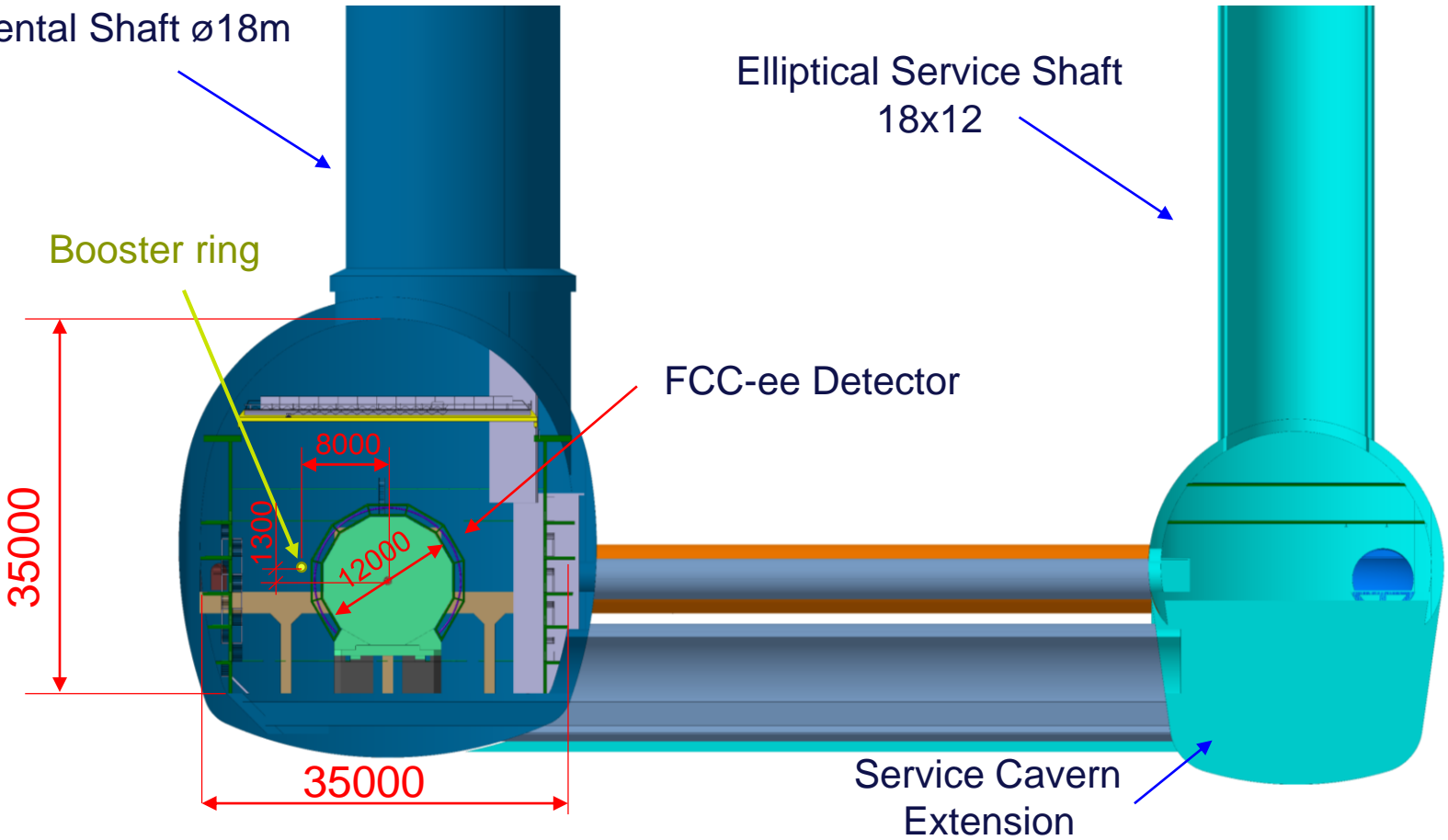

# FCC Experiment Underground Structure point A

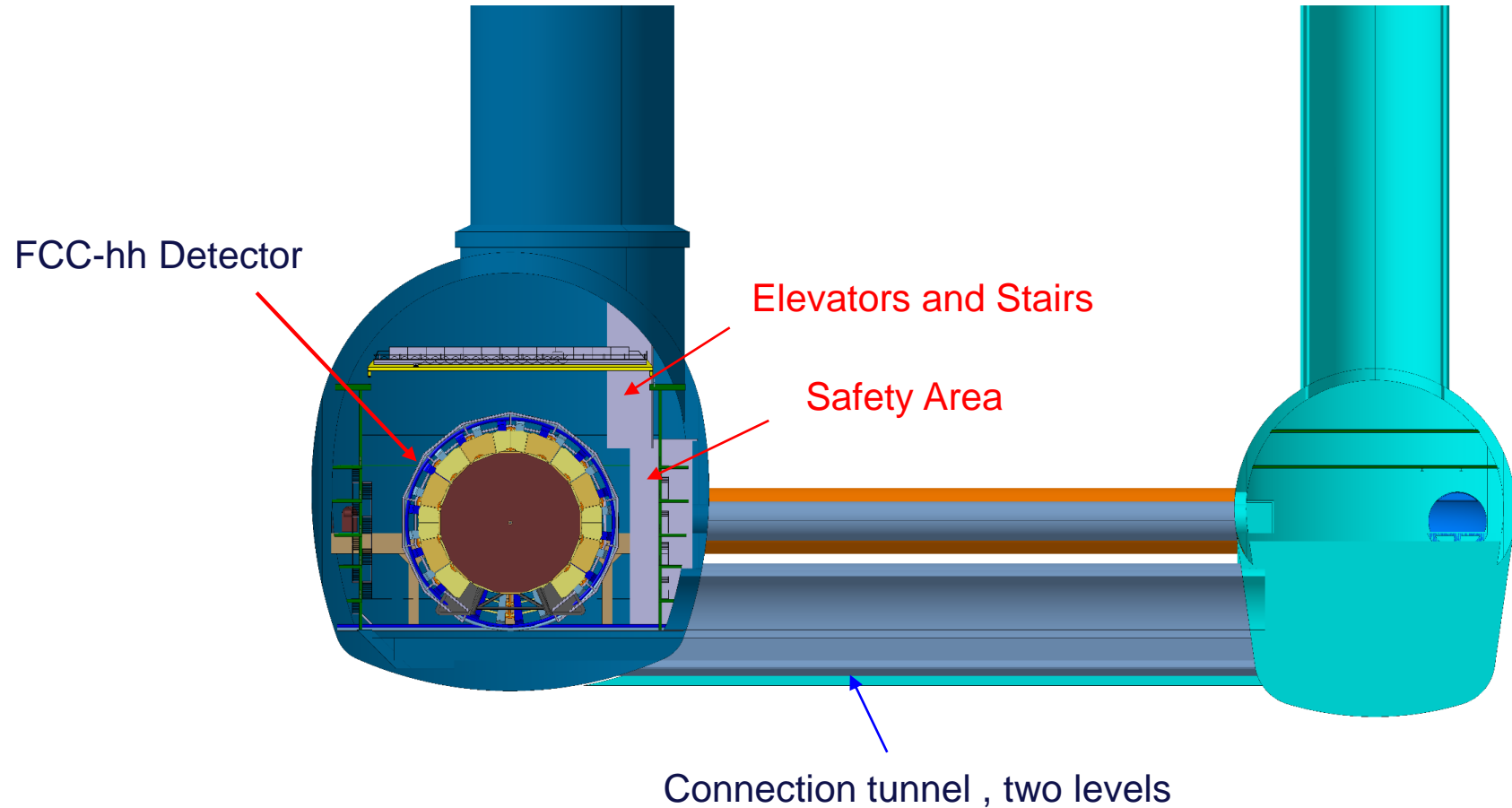



# FCC Experiment Underground Structure point A

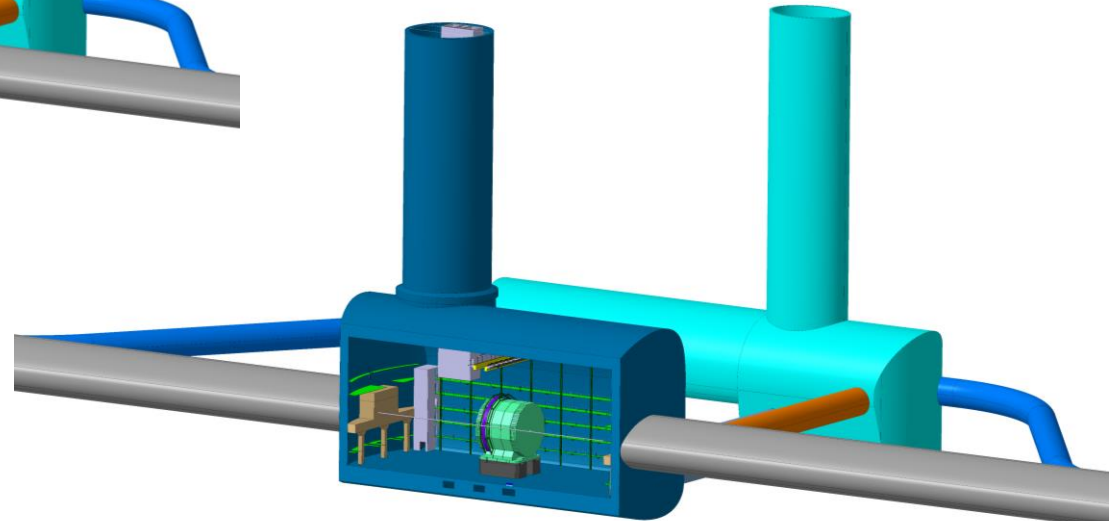
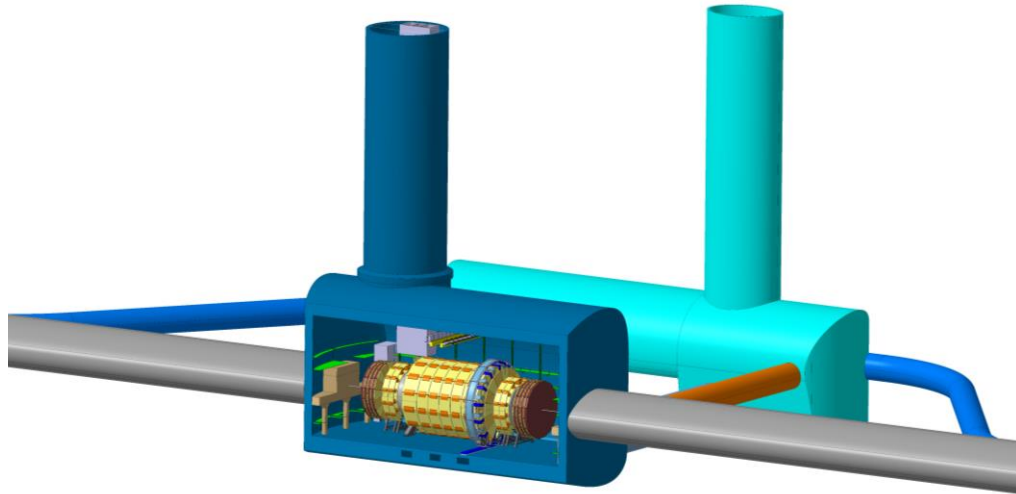

# FCC-ee beamstrahlung dump integration at point A

- E- ring
- E+ ring
- Booster ring
- Beamstrahlung Dump

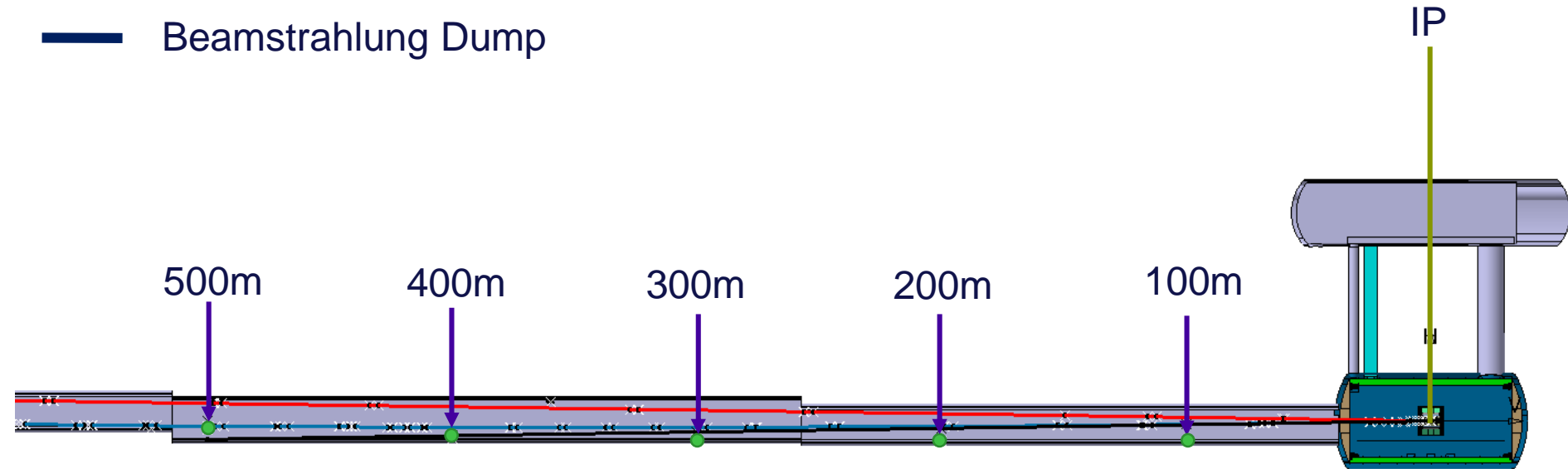

# FCC-ee beamstrahlung dump integration at point A

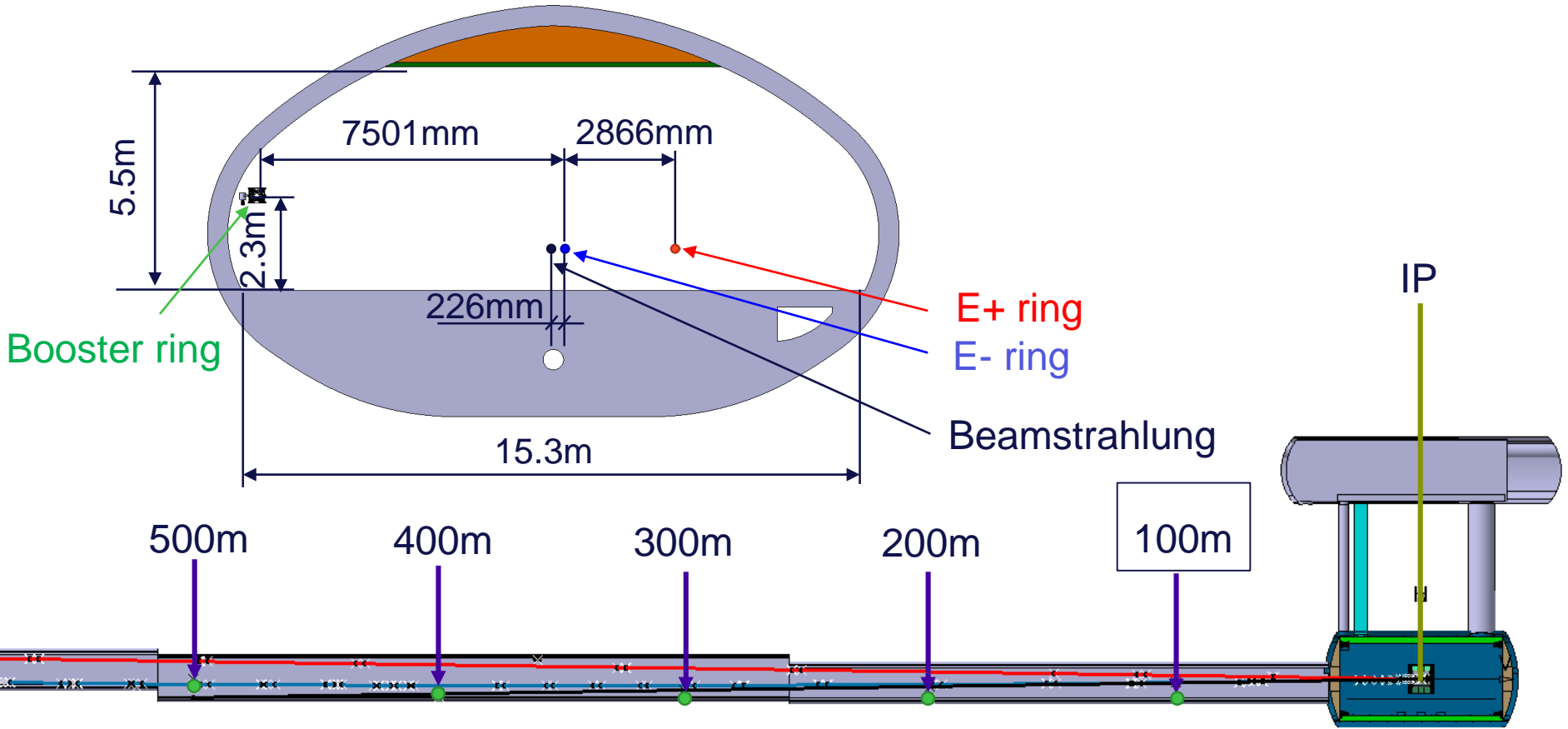

# FCC-ee beamstrahlung dump integration at point A

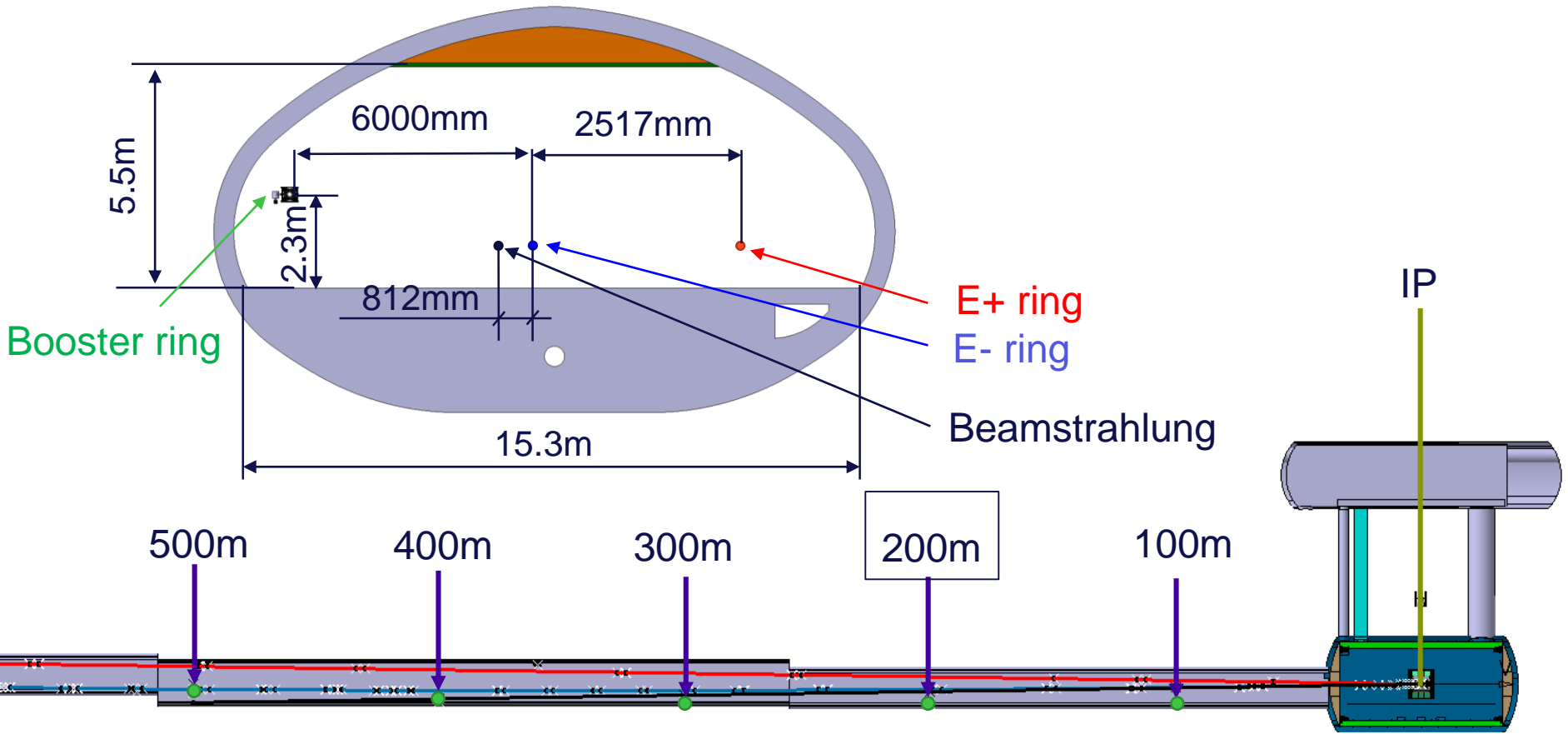

# FCC-ee beamstrahlung dump integration at point A

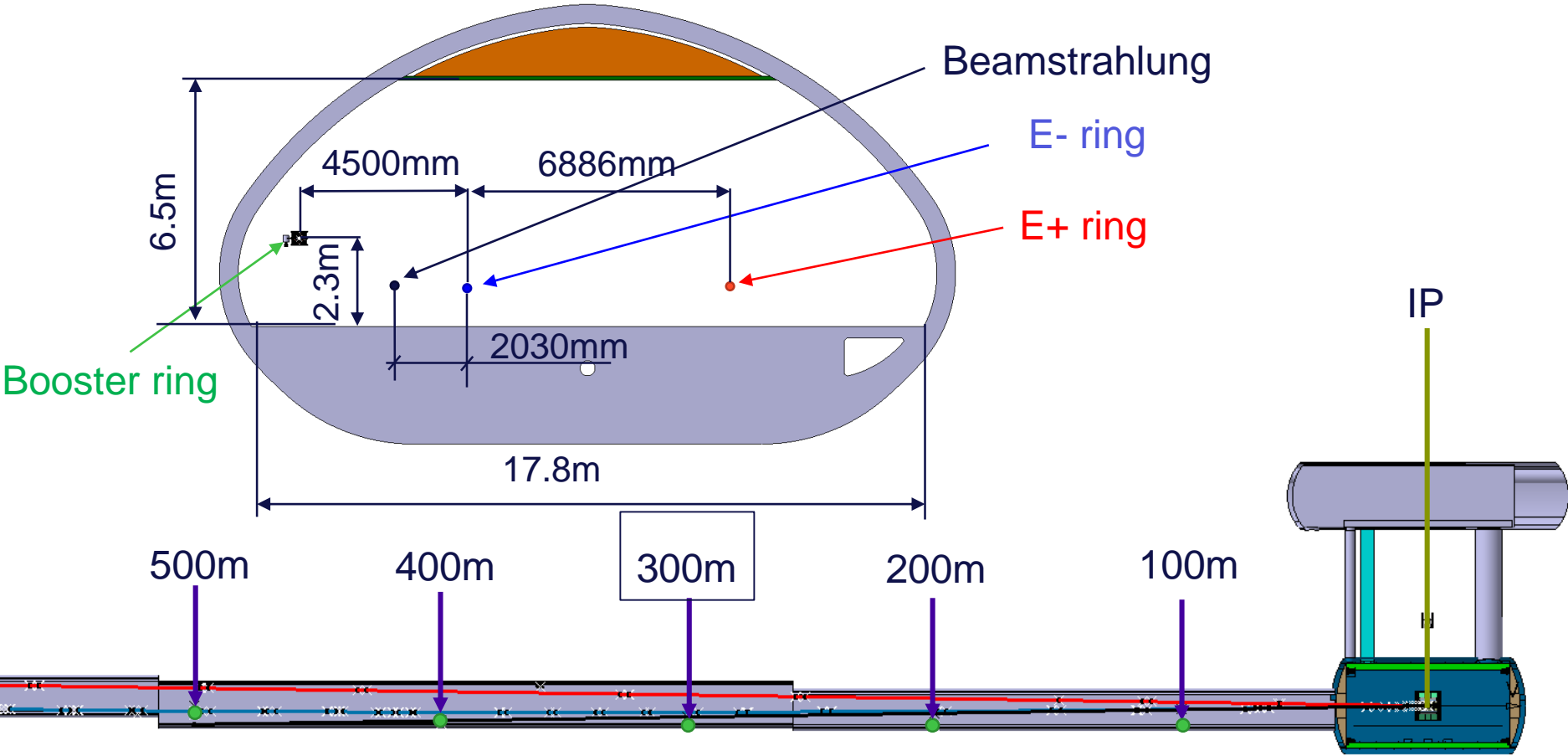

# FCC-ee beamstrahlung dump integration at point A

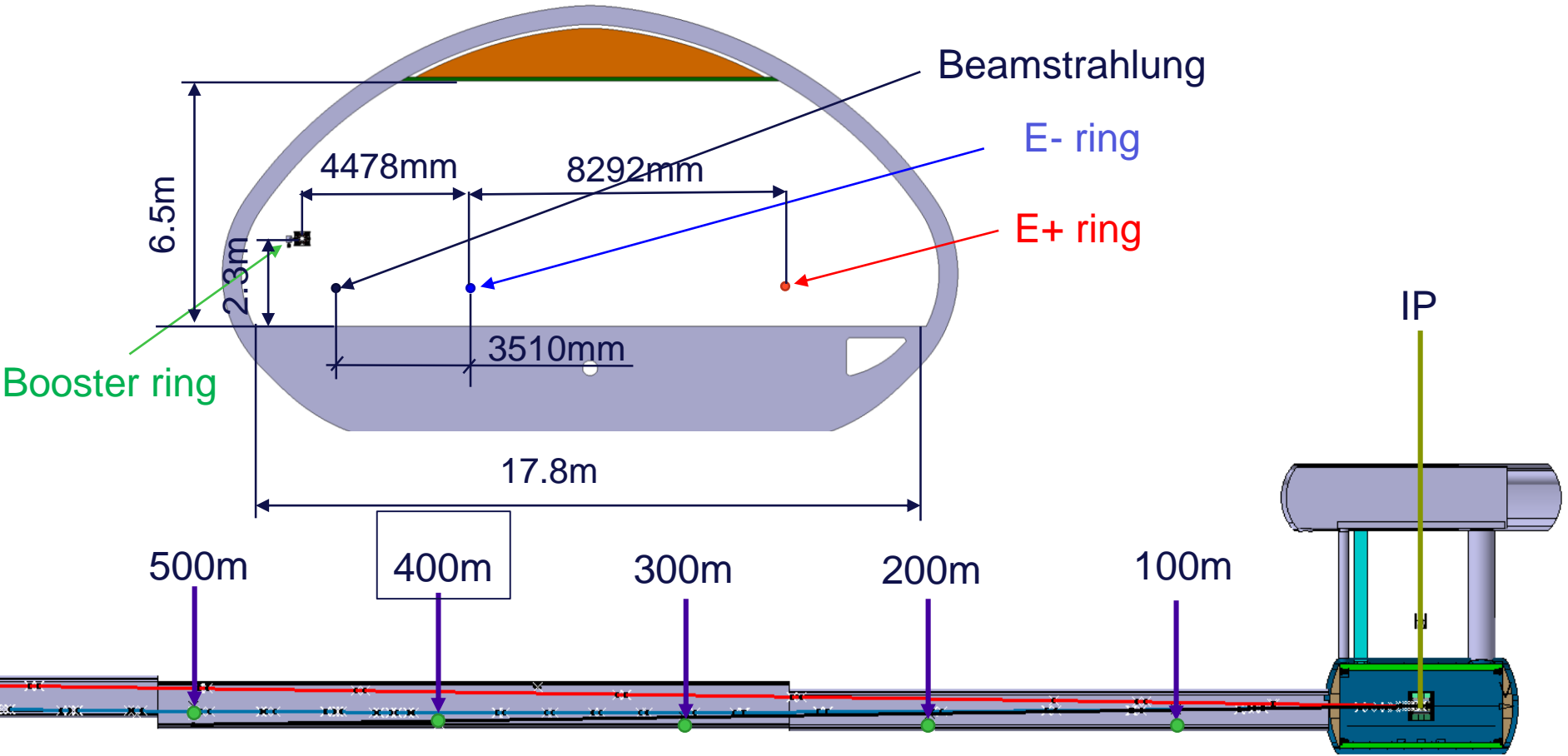

# FCC-ee beamstrahlung dump integration at point A

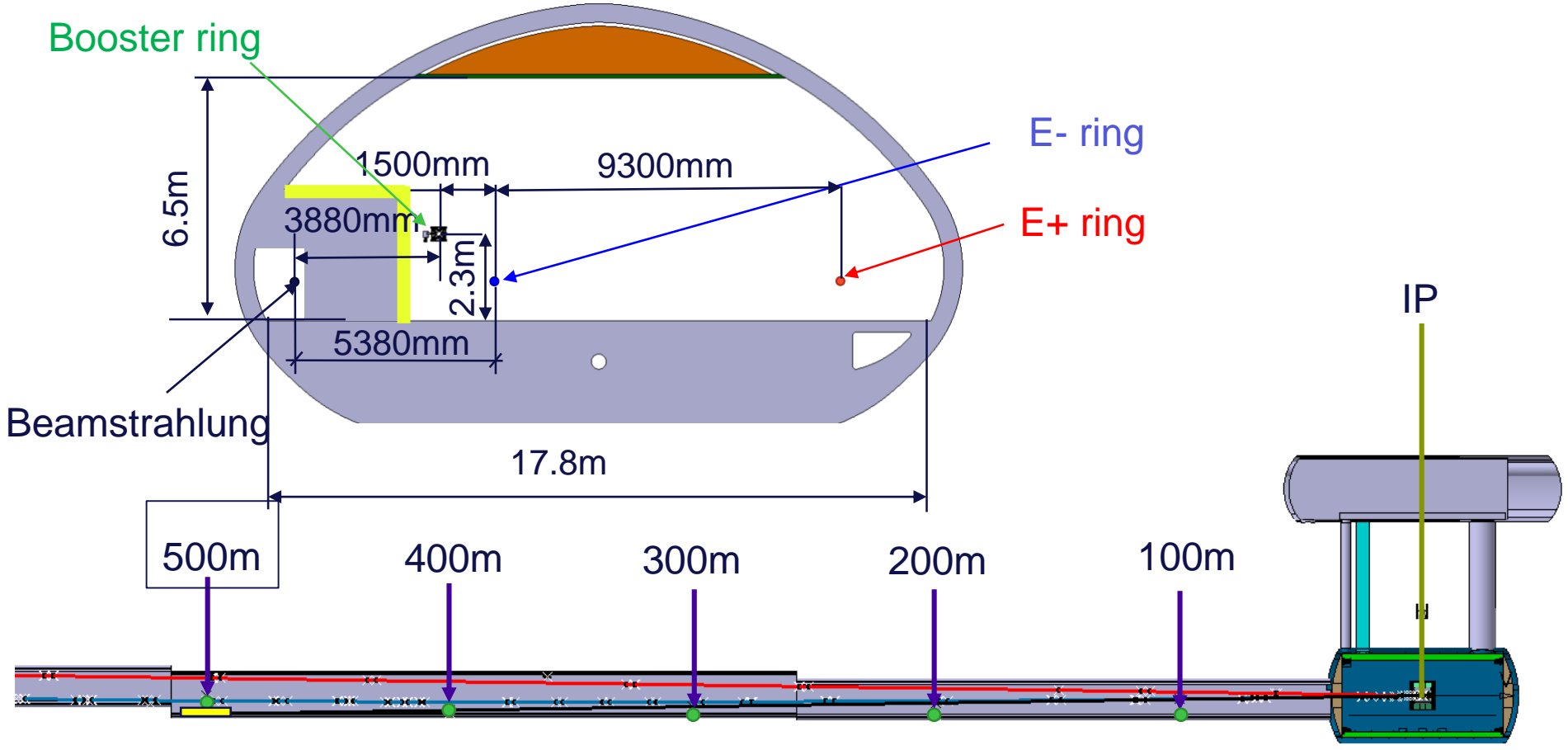



Thank you  
for your attention.