

# Accelerator Physics Requirements for Electron Cooler at the EIC Injection Energy

Alexei Fedotov, Dmitry Kayran, Sergei Seletskiy  
*Collider-Accelerator Department*  
Brookhaven National Laboratory

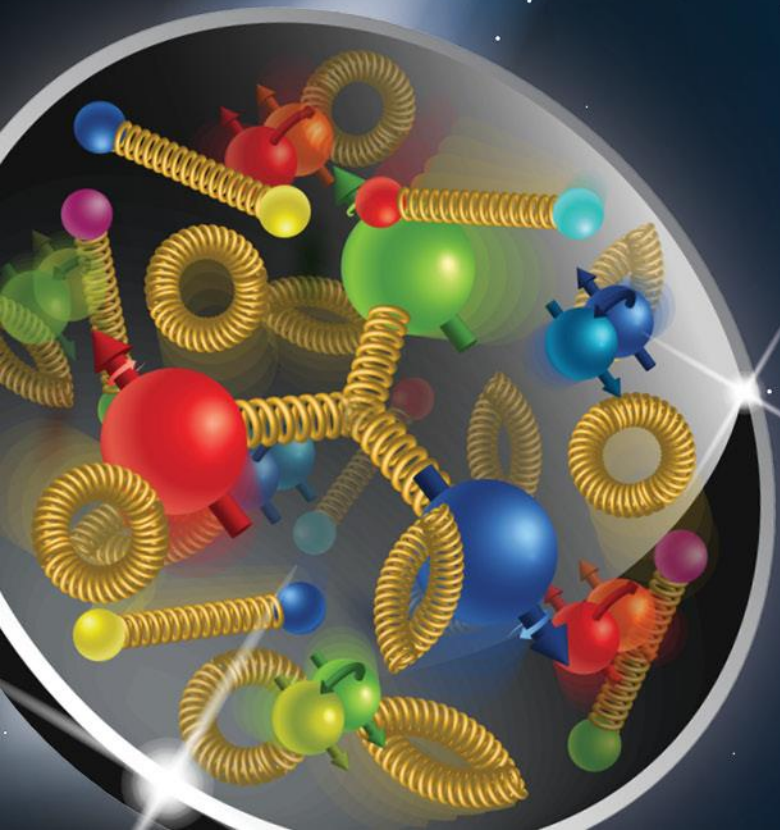

8th - 13th October 2023  
Royal Plaza Hotel  
Montreux  
Switzerland

Electron-Ion Collider

# Outline

- Electron Ion Collider (EIC) cooling requirements
- EIC cooling methods and coolers
- High-energy cooling in EIC
- Precooling at the EIC injection energy
- Precooler design parameters
- Precooler challenges
- Summary



# EIC Introduction

- Design is based on **existing RHIC complex**
  - RHIC accelerator chain will provide EIC hadrons
- High luminosity interaction region(s)
  - $L = 10^{34} \text{cm}^{-2} \text{s}^{-1}$
- Hadron Storage Ring (HSR: RHIC Rings) 40-275 GeV
  - Supplied by AGS and Booster Injectors
  - **Hadron cooling**
- Electron Storage Ring (ESR) 5–18 GeV
  - Need to inject polarized bunches every second
- Rapid Cycling Synchrotron (RCS)
  - Designed to supply polarized bunches to the ESR every second
  - Polarized e-source and pre-injector

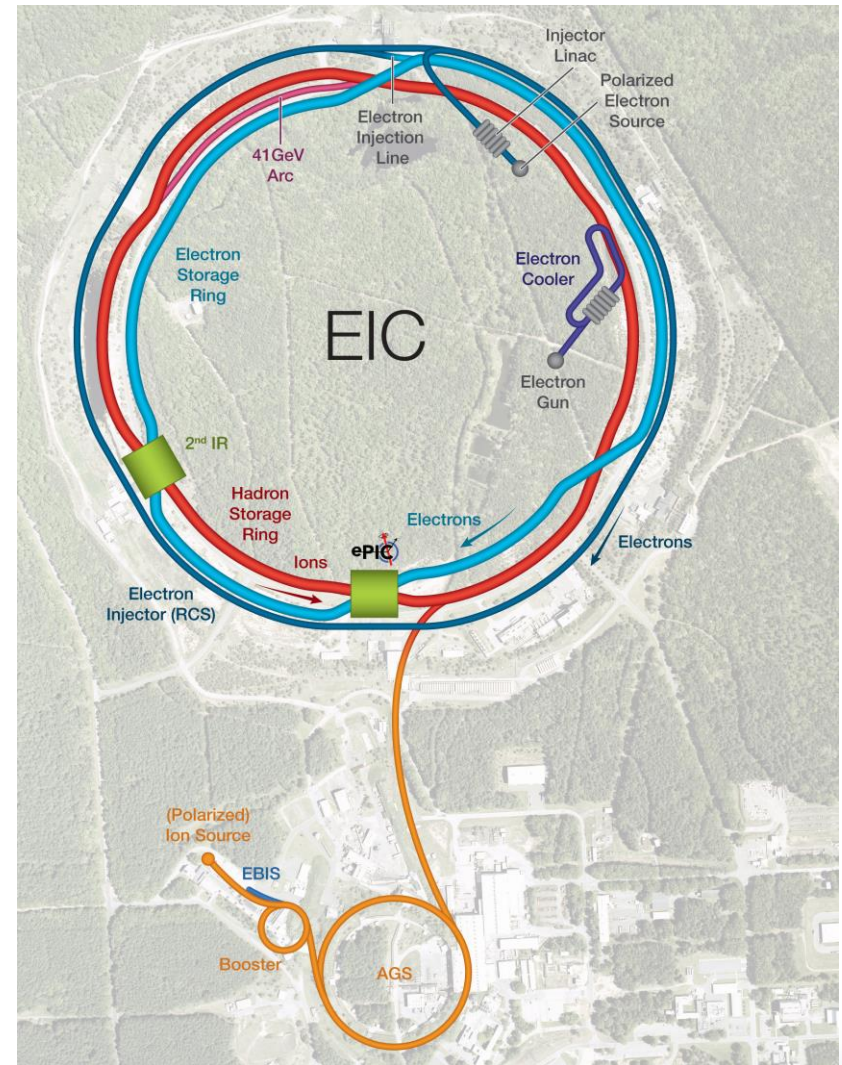

$E_{\text{cm}} = 20 \text{ GeV} - 141 \text{ GeV}$   
High luminosity goal:  $L = 10^{34} \text{cm}^{-2} \text{s}^{-1}$

# High Luminosity and Hadron Cooling

- The luminosity in the EIC strongly benefits from cooling of hadrons transverse and longitudinal beam emittances.
- At collision energies, IBS longitudinal and transverse(h) growth time is 2-3 hours. Beam-beam growth time(v) is > 5 hours. The cooling time shall be equal to or less than the diffusion growth time.

## With Hadron Cooling:

- EIC design luminosity  
 $L = 1 \cdot 10^{34} \text{cm}^{-2} \text{s}^{-1}$  at  $E_{\text{cm}} = 105 \text{ GeV}$  can be achieved & full range of EIC physics exploited.

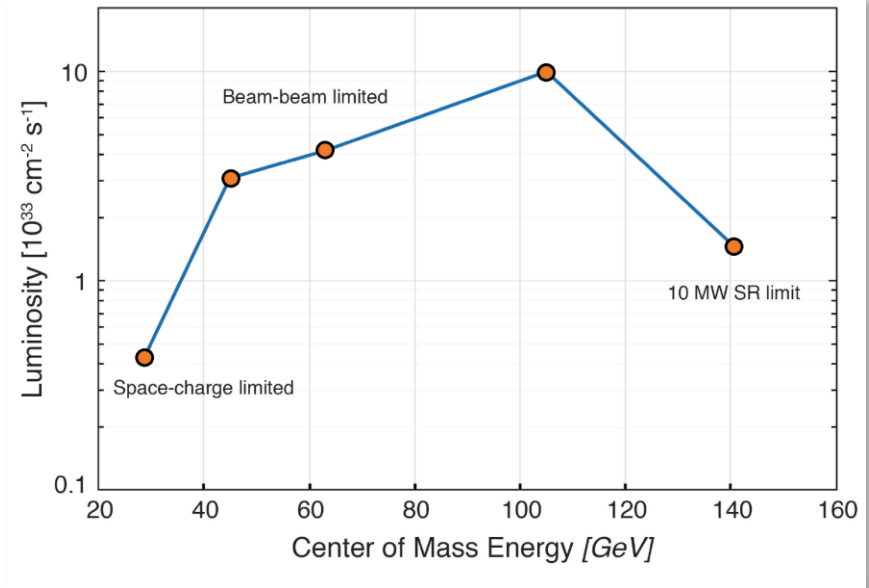

Integrated luminosity with cooling is 10 x larger than without cooling.

# Hadron cooling requirements for EIC

## High-energy cooling of protons (275, 100 GeV):

At EIC proton collision energies of 41, 100 and 275 GeV, cooling should counteract longitudinal and transverse emittance growth and maintain close to initial beam emittances.

## Low-energy Cooling:

- **Precooling of protons at injection energy (24 GeV):**

The goal of cooling at injection energy of protons (**Precooling**) is to obtain initial proton parameters by cooling vertical emittance to 0.3-0.5  $\mu\text{m}$  (rms normalized). This requires 13 MeV electron accelerator.

- **Cooling protons at low collision energy (41 GeV):**

13 MeV electron cooler (**Precooler**) can be extended to 22 MeV, which would provide required cooling for protons at collision energy of 41 GeV.

# Cooling methods for EIC

- **Electron Cooling (13MeV):**

Precooling of protons at injection energy of 24 GeV to reduce vertical emittance to 0.3  $\mu\text{m}$  (rms, normalized).

- **Electron Cooling (22MeV):**

Cooling of protons at collision energy of 41 GeV.

- **Coherent Electron Cooling, CeC (55, 150MeV):**

High-energy cooling of protons at collision energies of 100, 275 GeV.

- **Electron Cooling (55, 150MeV):**

High-energy cooling of protons. Considered as a backup for CeC method.



# High energy cooling based on CeC

Similar to **stochastic cooling**, tiny fluctuations in the hadron beam distribution are **detected, amplified** and **fed back** to the hadrons **by electron beam**, reducing emittance of the hadron beam.

- High bandwidth (small slice size)
- Detector (Modulator), amplifier and feedback (kicker)

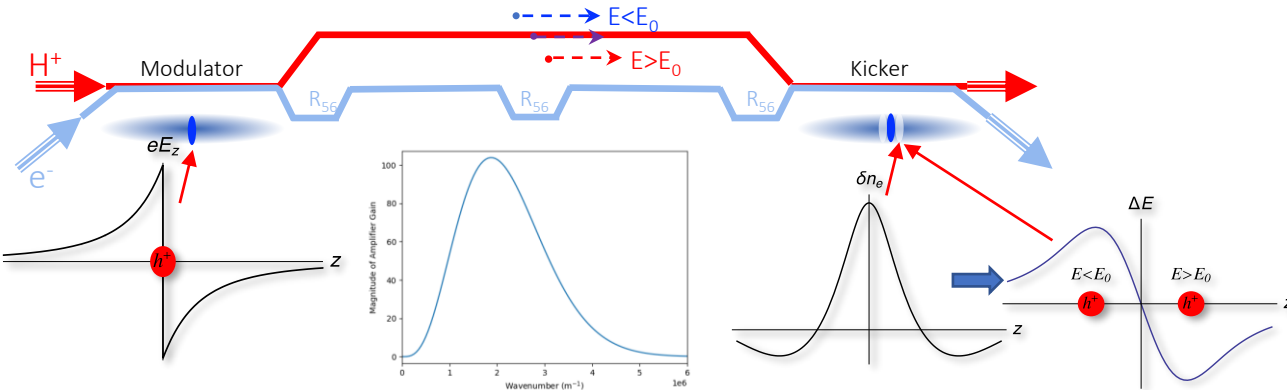

For high-energy protons, a large bandwidth (tens of THz) is required:  
➔ **Using an electron beam** to **pickup** fluctuations, to **amplify** and to **kick** back.

EIC CDR baseline Amplification method: micro-bunched amplifier.

# EIC High Energy-CeC/Precooler facility layout

COOL'23 presentation:  
K. Dietrick et al.

## EIC High-Energy CeC-based cooler (Strong Hadron Cooling, SHC) design:

E. Wang et al., "The accelerator design progress for EIC strong hadron cooling", IPAC21 (2021).

W. Bergan et al., "Design of the MBEC Cooler for the EIC", IPAC21 (2021).

C. Gulliford et al., "Design and optimization of an ERL for cooling EIC hadron beams", IPAC23 (2023).

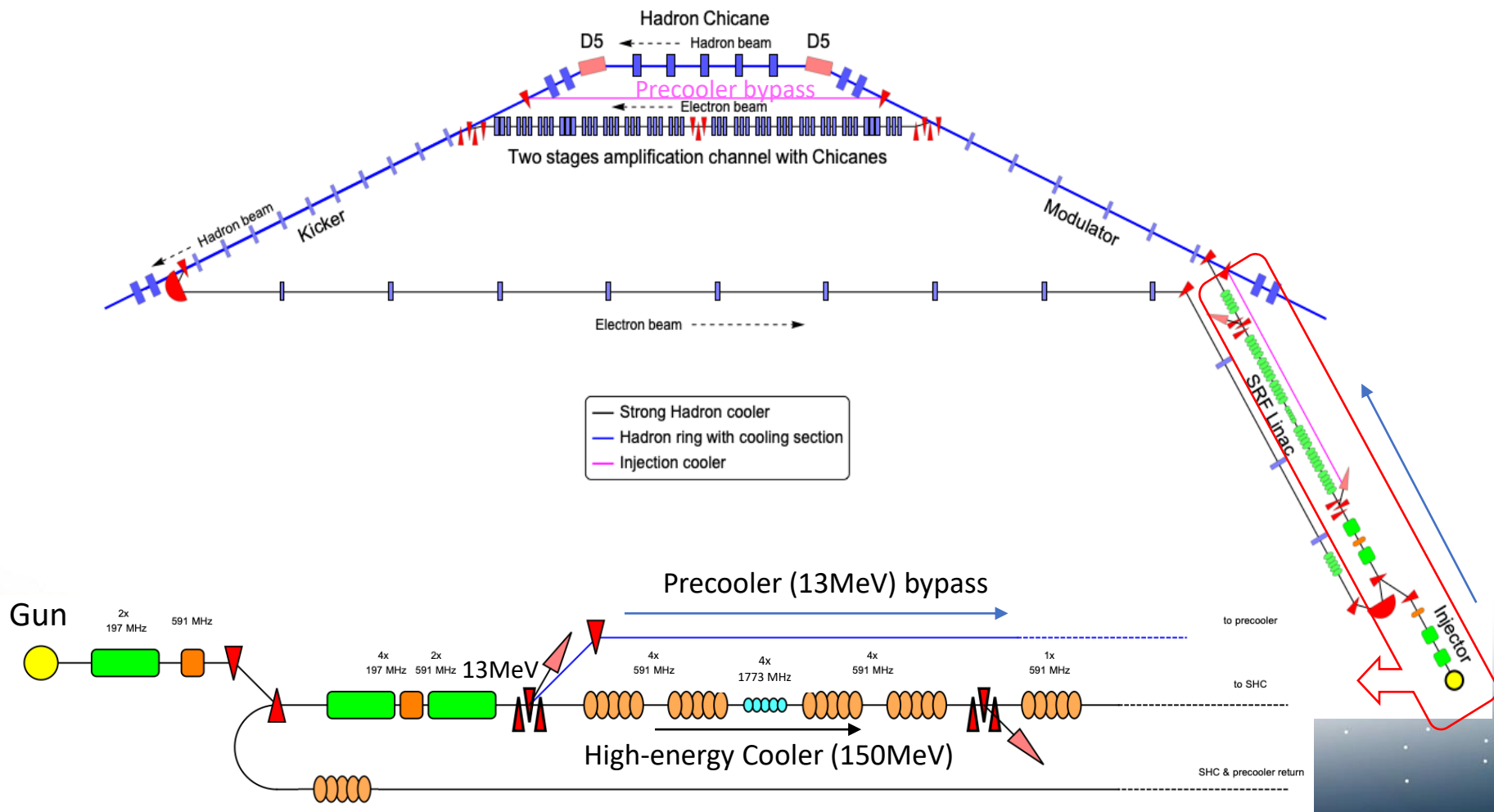



# CeC-X: Proof of Principle experiment

COOL'23 talks:  
V. Litvinenko et al.  
Y. Jing et al.  
G. Wang et al.

At BNL, efforts are underway to demonstrate CeC experimentally.

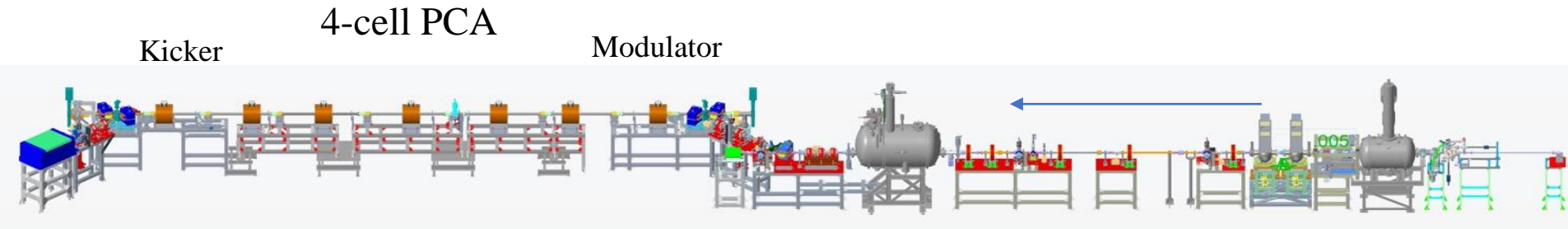

- 2014-17: Built and commissioned electron accelerator.
- 2018: Experiments with FEL-based CeC.
- 2019: Built and commissioned PCA-based system.
- 2020-23: Experiments towards PCA-amplified CeC.

# Electron Cooling



The method of electron cooling was presented by G.I. Budker (Novosibirsk) in Saclay, 1966.

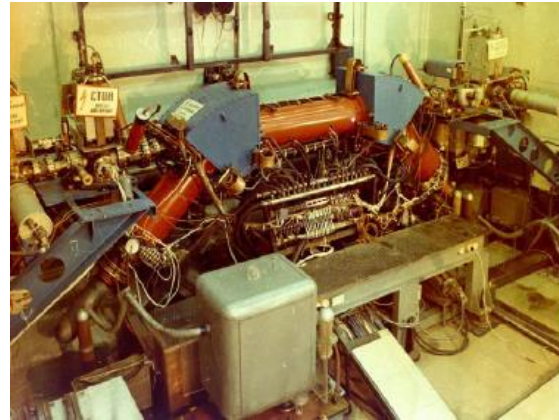

First experimental demonstration of electron cooling at NAP-M storage ring (Novosibirsk, 1974).

- **Electron Cooling is a well-established technique with almost 50 years of experimental experience.**

**High Voltage DC coolers: (1974-):** all DC electrostatic accelerators; all use magnetic field to confine electron beam (magnetized cooling). FNAL Recycler cooler: Pelletron electrostatic generator (4MeV electrons), transport of electron beam without continuous magnetic field.

**RF acceleration (High Energy approach): BNL LReC electron cooler (2019-21):** First RF-linac based electron cooler (**approach is directly extendable to higher energies**). LReC does not use any magnetization of electrons. LReC was successfully used for RHIC operations in 2020-21 to cool ion bunches directly at collision energy.

# Electron Cooling at high energy

Cooling rate

$$\lambda \propto \frac{r_e^2 m_e c Z^2 \Lambda_c}{A_i m_p} \cdot \frac{1}{\gamma^2} \cdot \frac{N_e}{\varepsilon_{xn} \varepsilon_{yn} \sigma_z \sigma_\delta} \cdot \frac{L_{CS}}{C_{ring}}$$

Reduction in a cooling rate with energy can be compensated by:

- Increasing the 6-D phase space density of the electron bunch
- Increasing the length of the cooling section
- Precooling an ion bunch, because ions with a small velocity spread are cooled faster

What is needed is to design accelerator which can provide electron beam parameters required for cooling.

Several approaches to electron accelerator were considered.

# High-energy cooling for EIC

Several approaches based on **conventional electron cooling**, as **alternative** to Coherent Electron Cooling (which is present baseline for EIC Strong Hadron Cooling), were considered:

## 1. Induction Linac based Ring cooler (FNAL):

V. Lebedev, S. Nagaitsev et al., "CDR: A ring-based electron cooling for EIC", JINST 16 T01003 (2021).

## 2. Dual-ring electron accelerator (JLAB):

B. Dhital et al., "Beam dynamics study in a dual energy storage ring for ion beam cooling", Proc. IPAC21, TUXA07 (2021).  
 COOL'23 talk: F. Lin et al.

## 3. ERL-based Circulator Ring (JLAB):

S. Benson et al., ERL19, LINAC20 presentations

## 4. Storage Ring electron cooler (BNL):

H. Zhao, J. Kewisch et al., "Ring-based electron cooler for high energy beam cooling", PRAB 24, 043501 (2021)

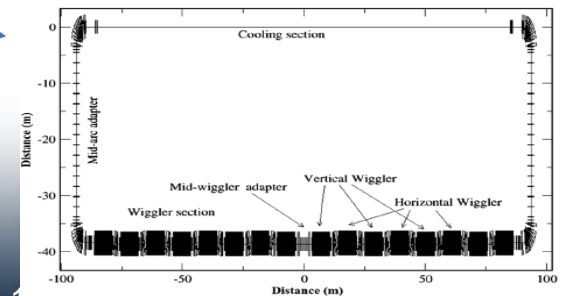
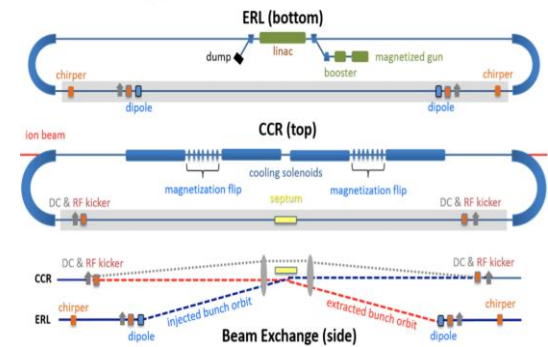
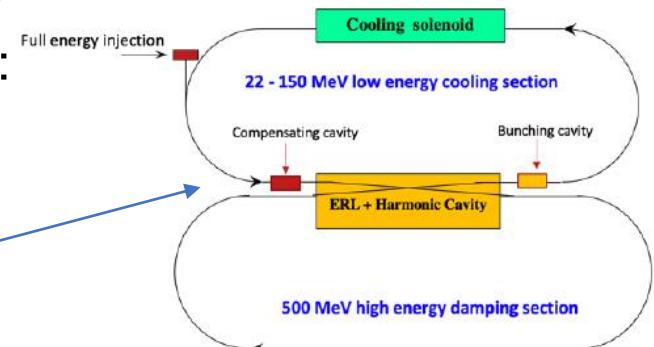
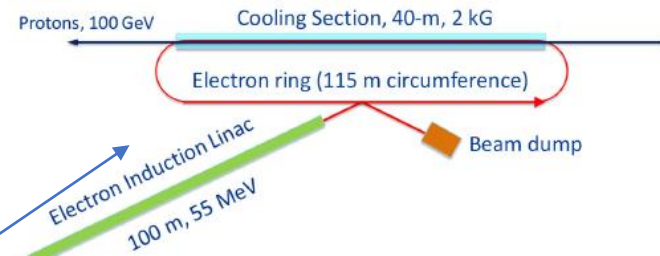

FIG. 2. Layout of the ring cooler.



# EIC Ring Electron Cooler

COOL'23 talk:  
S. Seletskiy et al.

- The **EIC Ring Electron Cooler** is a non-magnetized, bunched beam electron cooler based on an electron storage ring, which **utilizes damping wigglers to provide needed radiation damping for the electrons**.
- Ring cooler counteracts IBS-driven emittance growth of the proton bunches at 275 GeV with cooling times  $\tau_{cool(x,z)} = 2, 3$  hours.

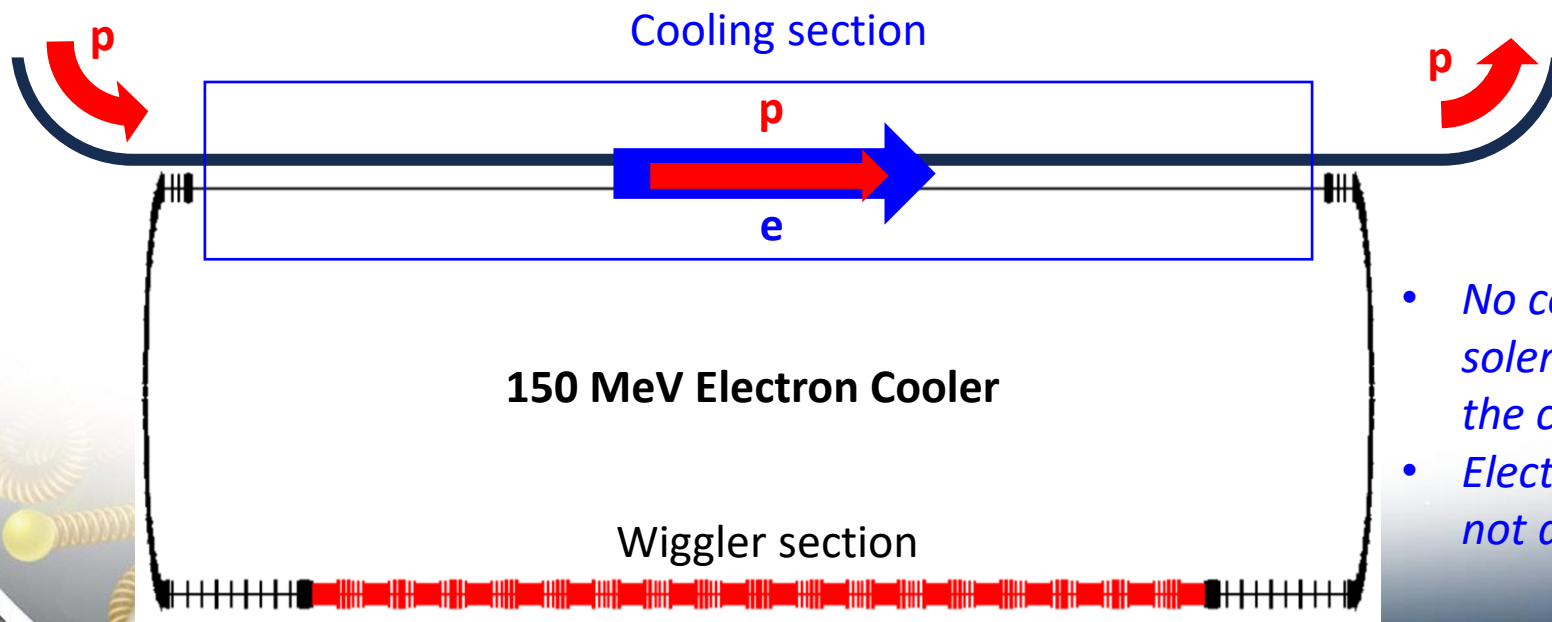

- *No continuous solenoidal field in the cooling section*
- *Electron bunches, not a DC beam*

# EIC cooling requirements for Precooler

Table 3.3: EIC beam parameters for different center-of-mass energies  $\sqrt{s}$ , with strong hadron cooling. High divergence configuration.

Species	proton	electron	proton	electron	proton	electron	proton	electron	proton	electron
Energy [GeV]	275	18	275	10	100	10	100	5	41	5
CM energy [GeV]	140.7		104.9		63.2		44.7		28.6	
Bunch intensity [ $10^{10}$ ]	19.1	6.2	6.9	17.2	6.9	17.2	4.8	17.2	2.6	13.3
No. of bunches	290		1160		1160		1160		1160	
Beam current [A]	0.69	0.227	1	2.5	1	2.5	0.69	2.5	0.38	1.93
RMS norm. emit., h/v [ $\mu\text{m}$ ]	5.2/0.47	845/71	3.3/0.3	391/26	3.2/0.29	391/26	2.7/0.25	196/18	1.9/0.45	196/34
RMS emittance, h/v [nm]	18/1.6	24/2.0	11.3/1.0	20/1.3	30/2.7	20/1.3	26/2.3	20/1.8	44/10	20/3.5
$\beta^*$ , h/v [cm]	80/7.1	59/5.7	80/7.2	45/5.6	63/5.7	96/12	61/5.5	78/7.1	90/7.1	196/21.0
IP RMS beam size, h/v [ $\mu\text{m}$ ]	119/11		95/8.5		138/12		125/11		198/27	
$K_x$	11.1		11.1		11.1		11.1		7.3	
RMS $\Delta\theta$ , h/v [ $\mu\text{rad}$ ]	150/150	202/187	119/119	211/152	220/220	145/105	206/206	160/160	220/380	101/129
BB parameter, h/v [ $10^{-3}$ ]	3/3	93/100	12/12	72/100	12/12	72/100	14/14	100/100	15/9	53/42
RMS long. emittance [ $10^{-3}$ , eV·s]	36		36		21		21		11	
RMS bunch length [cm]	6	0.9	6	0.7	7	0.7	7	0.7	7.5	0.7
RMS $\Delta p/p$ [ $10^{-4}$ ]	6.8	10.9	6.8	5.8	9.7	5.8	9.7	6.8	10.3	6.8
Max. space charge	0.007	neglig.	0.004	neglig.	0.026	neglig.	0.021	neglig.	0.05	neglig.
Piwinski angle [rad]	6.3	2.1	7.9	2.4	6.3	1.8	7.0	2.0	4.2	1.1
Long. IBS time [h]	2.0		2.9		2.5		3.1		3.8	
Transv. IBS time [h]	2.0		2		2.0/4.0		2.0/4.0		3.4/2.1	
Hourglass factor $H$	0.91		0.94		0.90		0.88		0.93	
Luminosity [ $10^{33}\text{cm}^{-2}\text{s}^{-1}$ ]	1.54		10.00		4.48		3.68		0.44	

Goal of precooling at injection energy of protons is to obtain required small vertical emittance of protons.

# LEReC electron cooler

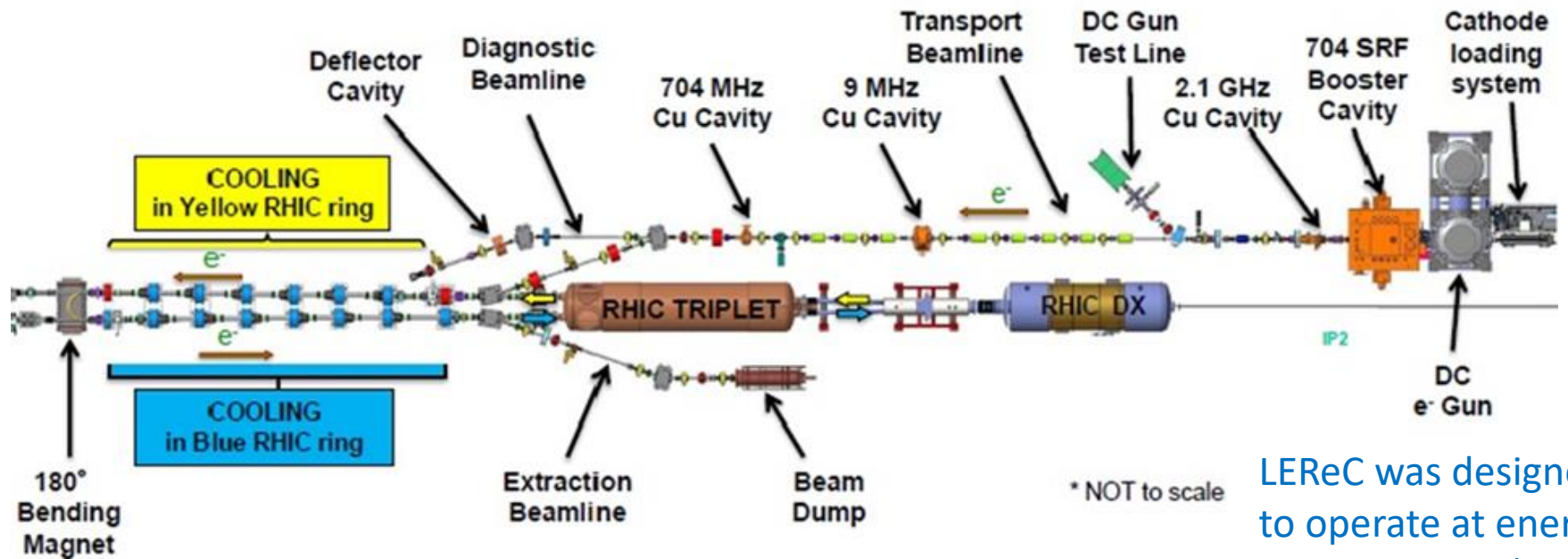

LEReC was designed to operate at energies up to 2.6 MeV\*.

\*A. Fedotov et al., in Proc. NAPAC'16, Chicago, IL, USA, Oct. 2016, pp. 867-869.

- **LEReC is fully operational electron cooler which:**

- utilizes **RF-accelerated** electron bunches
- uses non-magnetized electron beam (there is no magnetization at the cathode and there is no continuous solenoidal field in the cooling section)

- **LEReC approach was chosen for the EIC Precooler (13 MeV electron energy).**

# 13 MeV Precooler combined with 150 MeV HEC-CeC

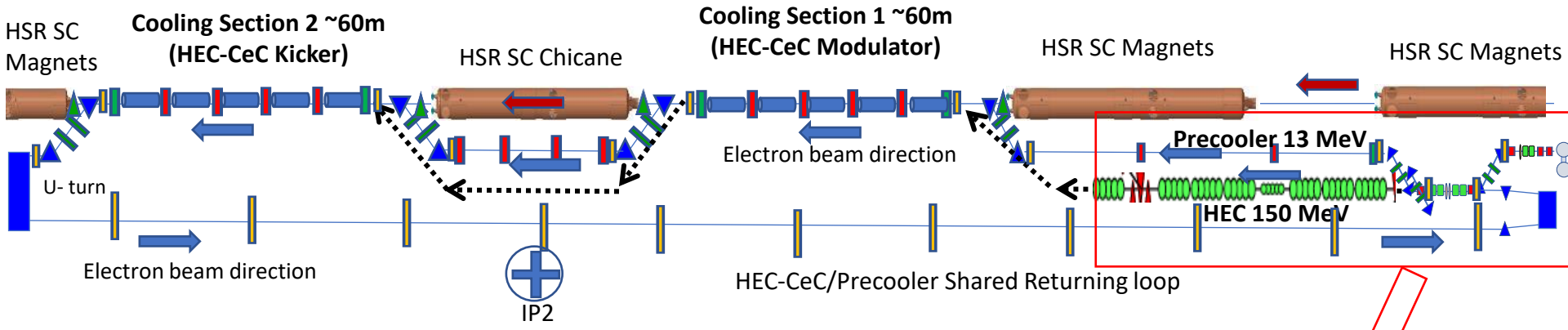

Zoom in

←..... SHC only transport  
 ▼ Hor. dipoles      Solenoids  
 ▽ Vertical dipoles      Quadrupoles  
 ■ 197MHz cavities      DC Gun  
 ○ 591 MHz cavities      DC Gun  
 ■ μ- shielding  
 ▲ 4 Hor. comp dipoles might be needed

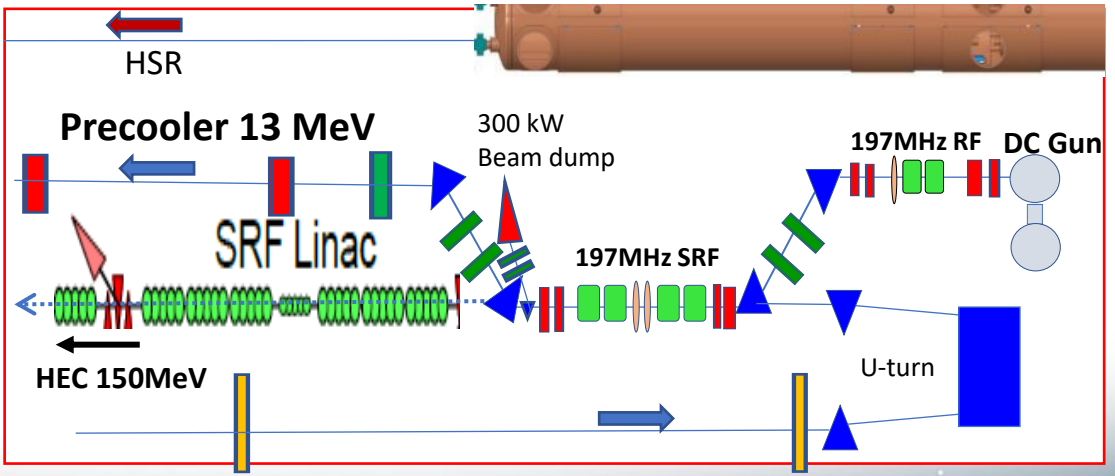



# Cooler parameters for protons at 23.8 GeV

	electrons	protons
gamma	25.4	25.4
RHIC RF frequency, MHz	197	24.6
Cooling section length, m	120	120
Cooling sections beta function, m	200	200
Hadrons Dx, Dx', m, rad		<0.5, <0.04
Charge per bunch, nC	4	45
Electrons kinetic energy, MeV	12.5	
Electron average current, mA	98	
Normalized emittance, rms, $\mu\text{m}$	1.5	2
rms bunch length, cm	5	70
rms dp/p	5e-4	6e-4
rms angles in cooling section, $\mu\text{rad}$	20*	20

\*Required rms angular spread of electrons is about factor of 5 smaller than in LEReC.

# Cooling simulations

Total electron charge per ion bunch:  $Q_{total}=4nC$   
 Average current of electrons:  $I_{av}=98mA$   
 Electrons rms angles in the cooling section:  $20\mu rad$   
 Effective cooling section length: **120 meters**

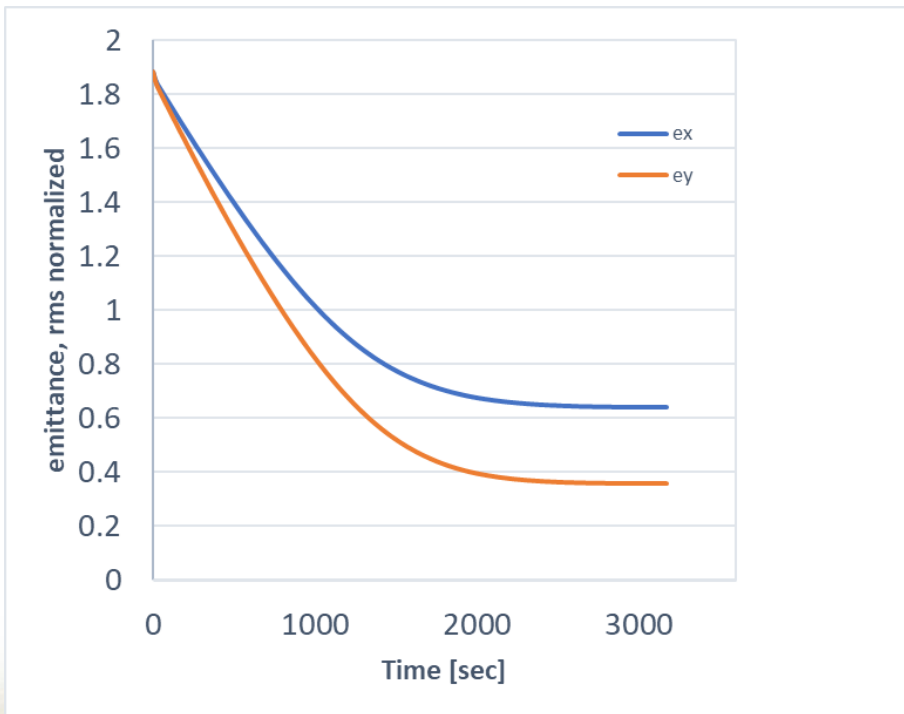

Fig. Cooling of protons at  $\gamma=25$ , with decoupled transverse motion (IBS+Cooling only).

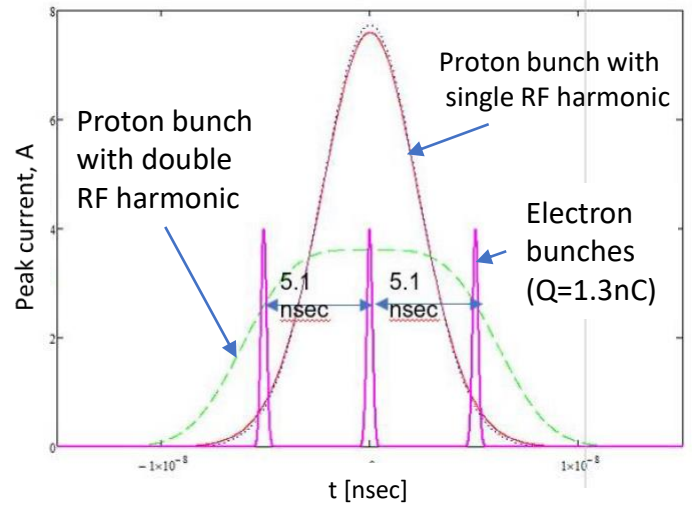
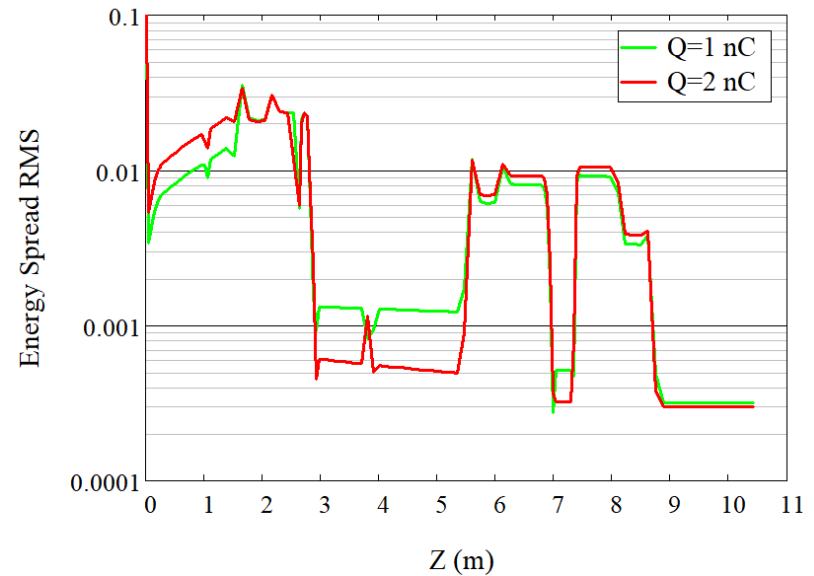
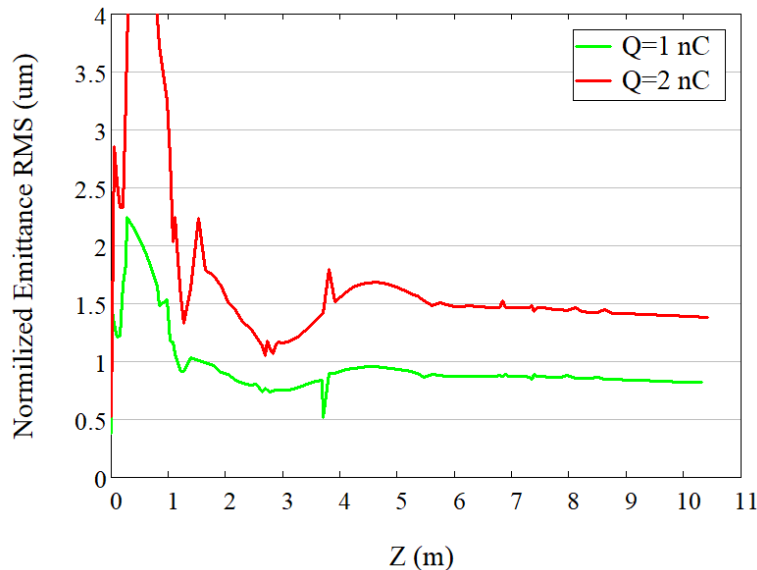
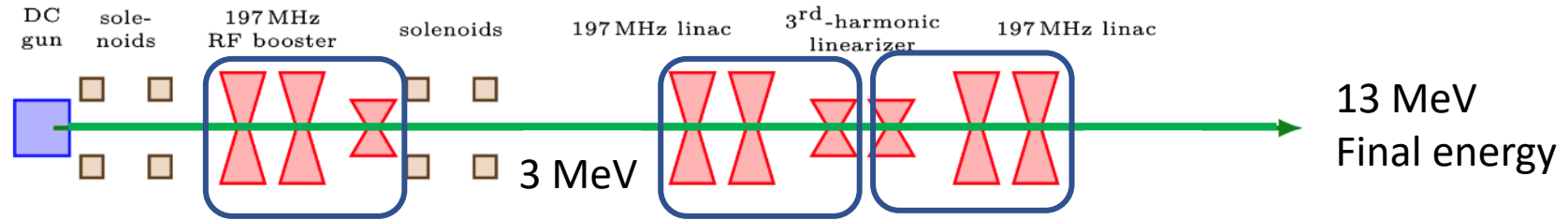

Fig. Electron beam time structure (3 electron bunches per single bunch of protons).

2<sup>nd</sup> harmonic RF alleviates space-charge effects reducing peak current of protons to about 3A (space charge tune shifts after cooling  $\Delta Q_{sc,x,y}=0.06, 0.1$ ), allowing vertical emittance to be cooled without introducing additional heating of horizontal emittance.

One can accelerate such cooled beams with 1:2 or 1:1 (round) emittance ratio to top energy, at which horizontal emittance can be increased as needed.

# Beam dynamics simulation



Achievable beam quality at the linac exit for bunch charge of 1-2 nC:

- Energy spread  $< 3e-4$
- Normalized emittance  $< 1.5\mu\text{m}$

Designed beta-function in cooling section 200 m, angular spread from emittance  $< 17 \mu\text{rad}$  (for 2nC bunches)

Simulations show that required electron beam parameters at 13 MeV can be achieved.

Such electron beam parameters should be preserved through very long electron beam transport and through the cooling sections.

# Cooling sections requirements

- The design of the cooling section will closely follow the LEReC approach\*.
- To maintain the transverse angle deviation of the electron beam trajectory  $< 20 \mu\text{rad}$ , the integral of residual transverse magnetic field between correctors in the cooling region **must be kept below  $1 \mu\text{Tm}$** .
- Shielding of the residual magnetic field to such level can be achieved using concentric cylindrical layers of high-permeability alloy in the cooling sections\*\*.
- Some cooling section space will be taken up by short weak solenoids, which control the angular spread of the electron beam due to its space charge.

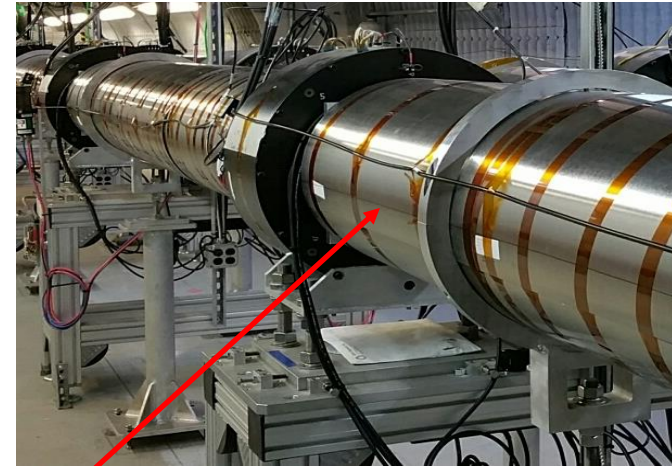

Picture: LEReC cooling sections.

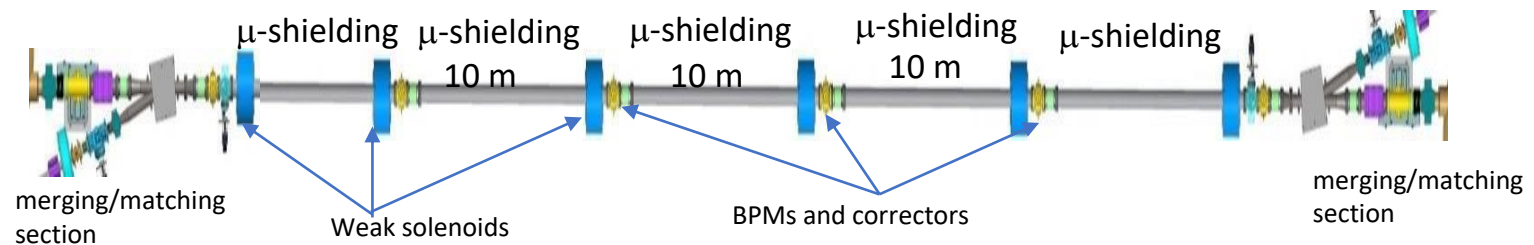

[\*] A. Fedotov et al., in Proc. NAPAC'16, Chicago, IL, USA, Oct. 2016, pp. 867-869.

[\*\*] S. Seletskiy et al., in Proc. NAPAC'16, Chicago, IL, USA, Oct. 2016, pp. 1030-1032.



# Electron angles in cooling sections

- Design of cooling sections and optimization of electron beam dynamics are being developed to minimize various contributions to electron angles in cooling sections.

## Largest contributions to electrons angles are:

- Electron beam emittance
- Electron beam space charge
- Focusing from proton beam
- Remnant magnetic fields

For electron bunches with about 2nC charge per bunch (highest planned electron intensities), several solutions were developed to keep total rms electron angular budget in cooling sections **around 20-30urad**.

We are now looking into optimization with lower intensity bunches, 1.3-1.4nC per bunch.

# Evolution of electron angles in cooling section

**Electron bunch charge of 2nC**  
Initial pulse duration **600 ps**  
 **$Q_{90\%} = 1.8 \text{ nC}$**  (90% of the beam)  
**Average divergence is around 20 $\mu$ rad**

For **non-uniform** electron distribution, space charge leads to tails of the distribution with large velocity spread. These particles do not contribute to cooling process and can be neglected for an estimate of effective portion of the beam participating in cooling.

Simulations of electron beam divergence (including space charge) through long cooling section.

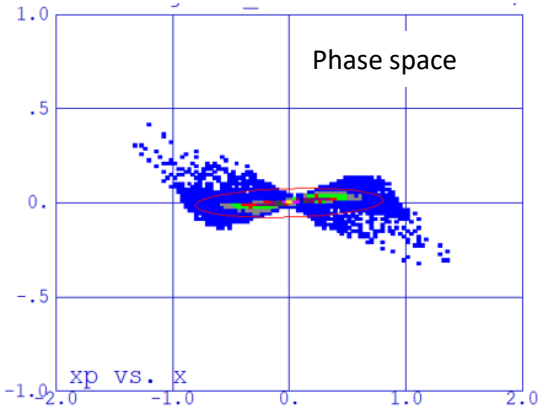
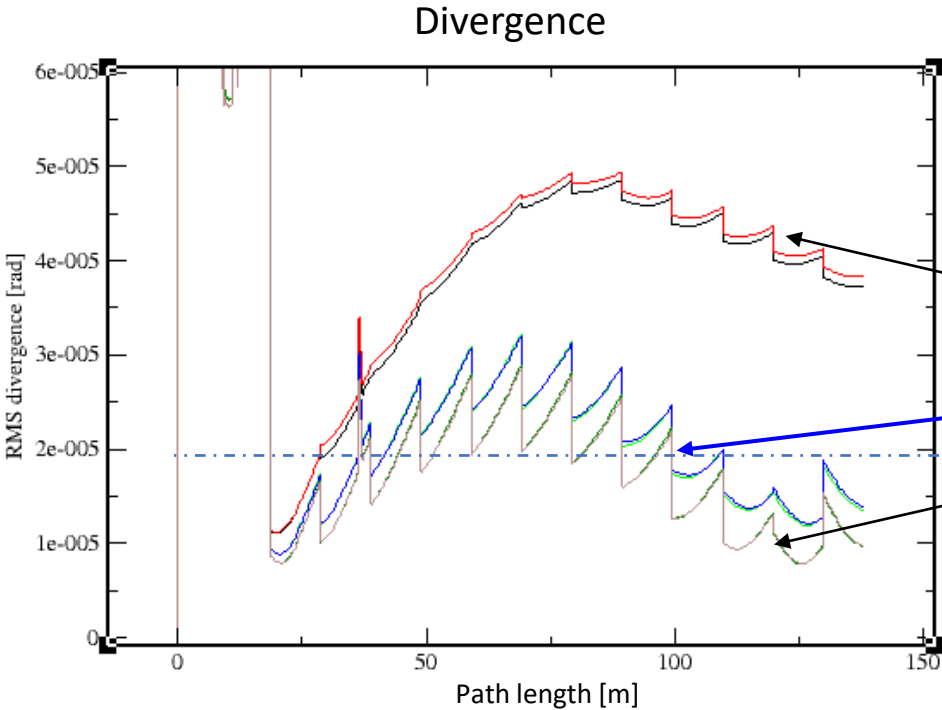

100% of the beam  
90% of the beam  
70% of the beam

# Precooler challenges

**Designing of 13MeV electron cooler to cool protons at 24 GeV is very challenging.**

Such a cooler requires:

- Achieving required electron beam parameters from injector
- Beam transport of electron bunches without significant degradation of beam emittance and energy spread at low energy (requires control of space charge and RF gymnastics)
- Achieving very small angular spread in cooling sections
- Operation of electron accelerator at high current

**Integration of 13MeV electron cooler with high-energy (150MeV) cooler based on CeC approach adds additional constraints:**

- Limited space available for effective cooling
- Additional merges and optics matching sections (due to split into two separate cooling sections)
- Finding proper solutions for mu-metal shielding of cooling sections with numerous magnetic elements needed for CeC-based cooler
- Linac SRF frequency should cover operation at low and high energy

# Summary

The luminosity in the EIC benefits strongly from hadron cooling.

LEReC-type RF-based electron cooler is being developed to provide cooling of protons at injection energy of 24 GeV. Such a Precooler requires 13 MeV electron accelerator.

Obtaining small angular spread of electrons (about factor of 5 smaller than in LEReC) in cooling sections is very challenging, especially with many additional constraints.

Precooler accelerator can be extended to 22 MeV to provide cooling of protons at a store energy of 41 GeV.

Optimization of Precooler parameters and its integration with the high-energy EIC coolers is in progress.

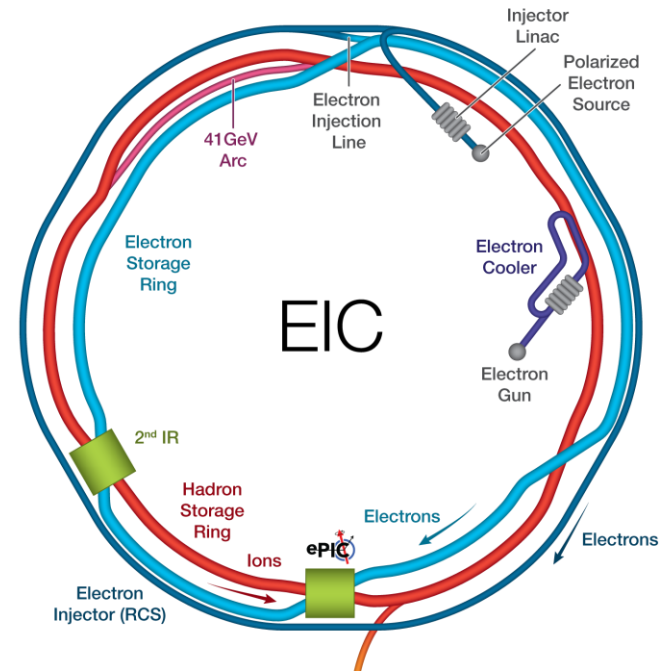



# Acknowledgement

Design of Electron Cooler for EIC injection energy of protons greatly benefits from help and expertise of many people from Brookhaven and Jefferson Lab EIC teams and BNL's Collider-Accelerator Department Beam Cooling Group.

Special thanks to Erdong Wang and Sergei Nagaitsev for many useful discussions and help.

Work supported by the U.S. Department of Energy.

Thank you!