

S. Rey*, W. Bastos, F. Caspers, B. Dupuy, D. Gamba, W. Hofle, R. Louwerse, L. Thorndahl
CERN, Geneva, Switzerland

Beam transfer function measurements have regularly been used to set-up the adjustable parameters for stochastic cooling systems.

Automation of these measurements at CERN enables efficient set-up of the cooling loops in the anti-proton decelerator (AD) and insight into the bandwidth (nominal frequency range of 850 MHz to 1.7 GHz) of the overall system for the longitudinal, horizontal and vertical cooling at the two different beam momenta of 2 GeV/c and 3.5 GeV/c.

Data collected in machine development sessions can be used to identify areas of improvement and will be indispensable in defining the planned path for consolidation and upgrade of the system.

It allows the comparison of the bandwidth with the computed shunt impedance of the currently used kickers. The unwanted interplay between the three different planes of cooling is also evaluated and will help to define improvements in the system for the future.

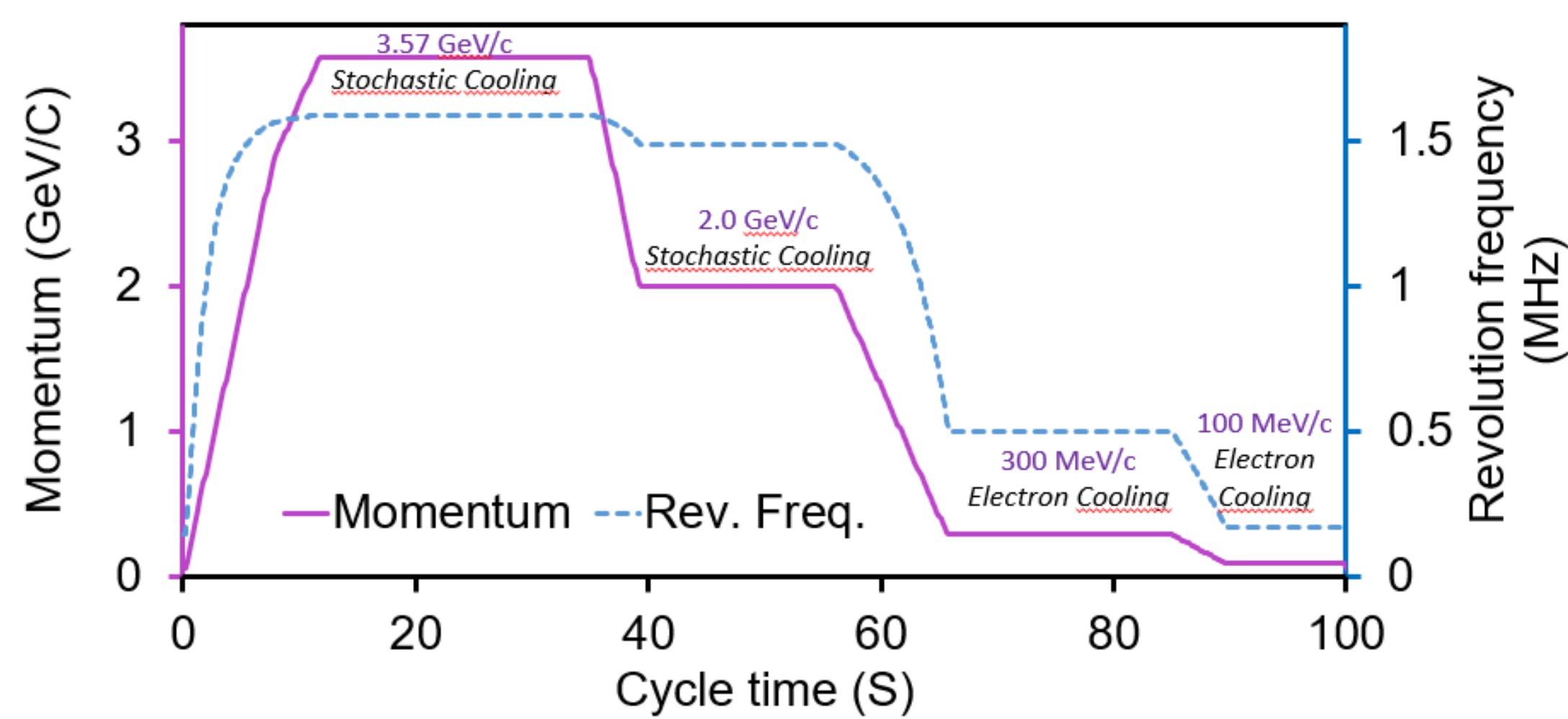

Figure 1 – The AD decelerating cycle

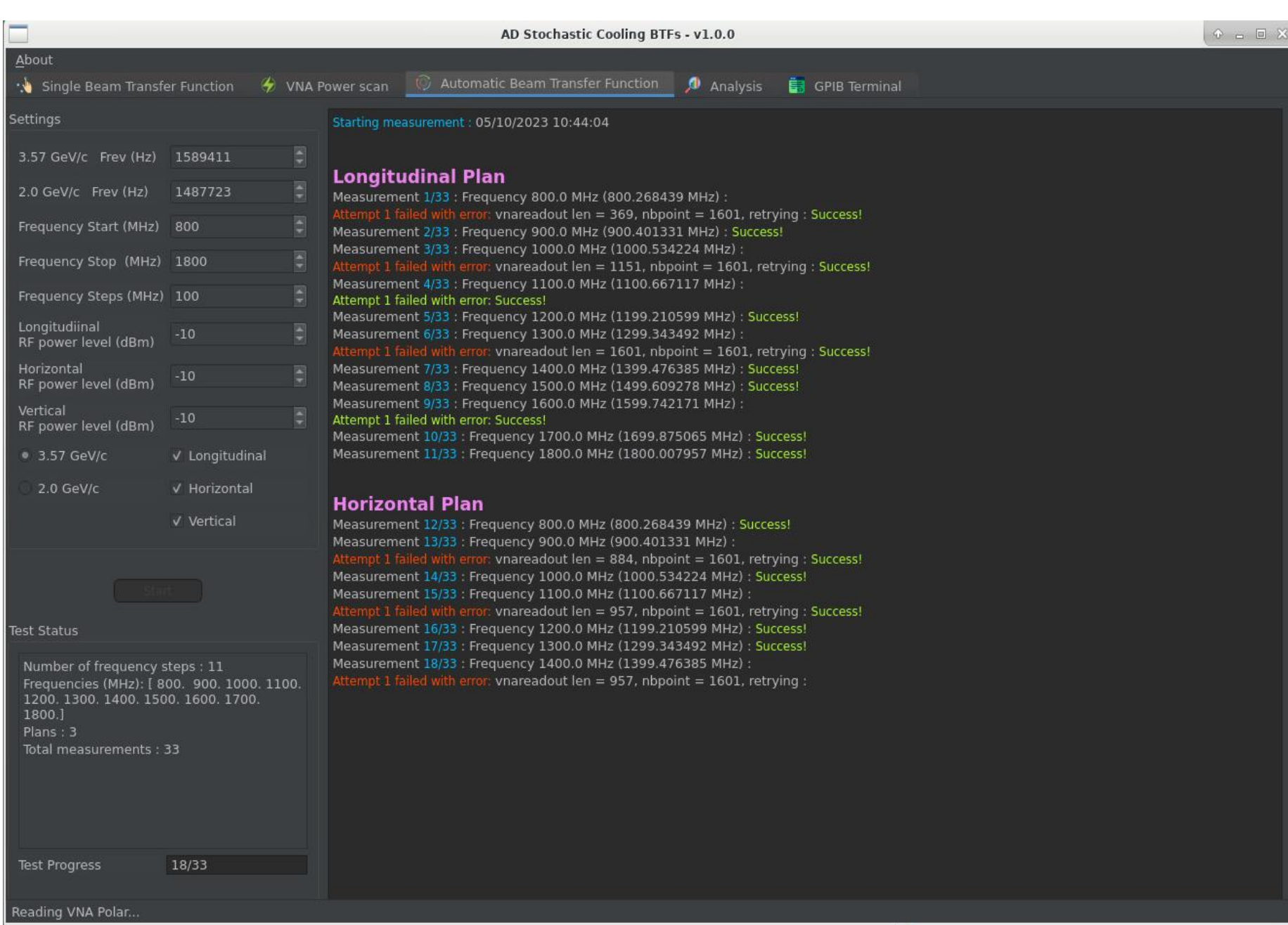

Figure 3 – Automated acquisition of VNA measurements

A Python application has been developed to offer a toolbox for conducting Beam Transfer Functions more quickly and accurately.

- Cycle through all the cooling plans and frequencies,
- Set and calibrate the VNA, and take measurements,
- Controls various machine relays and knobs,
- Provides a convenient method to analyse and display the processed data.

Figure 5 indicates that the longitudinal phase is incorrect :

- Correction by reducing the longitudinal delay and adjusting the phase.
- Measurements could be completed in 30 minutes instead of a full working day.

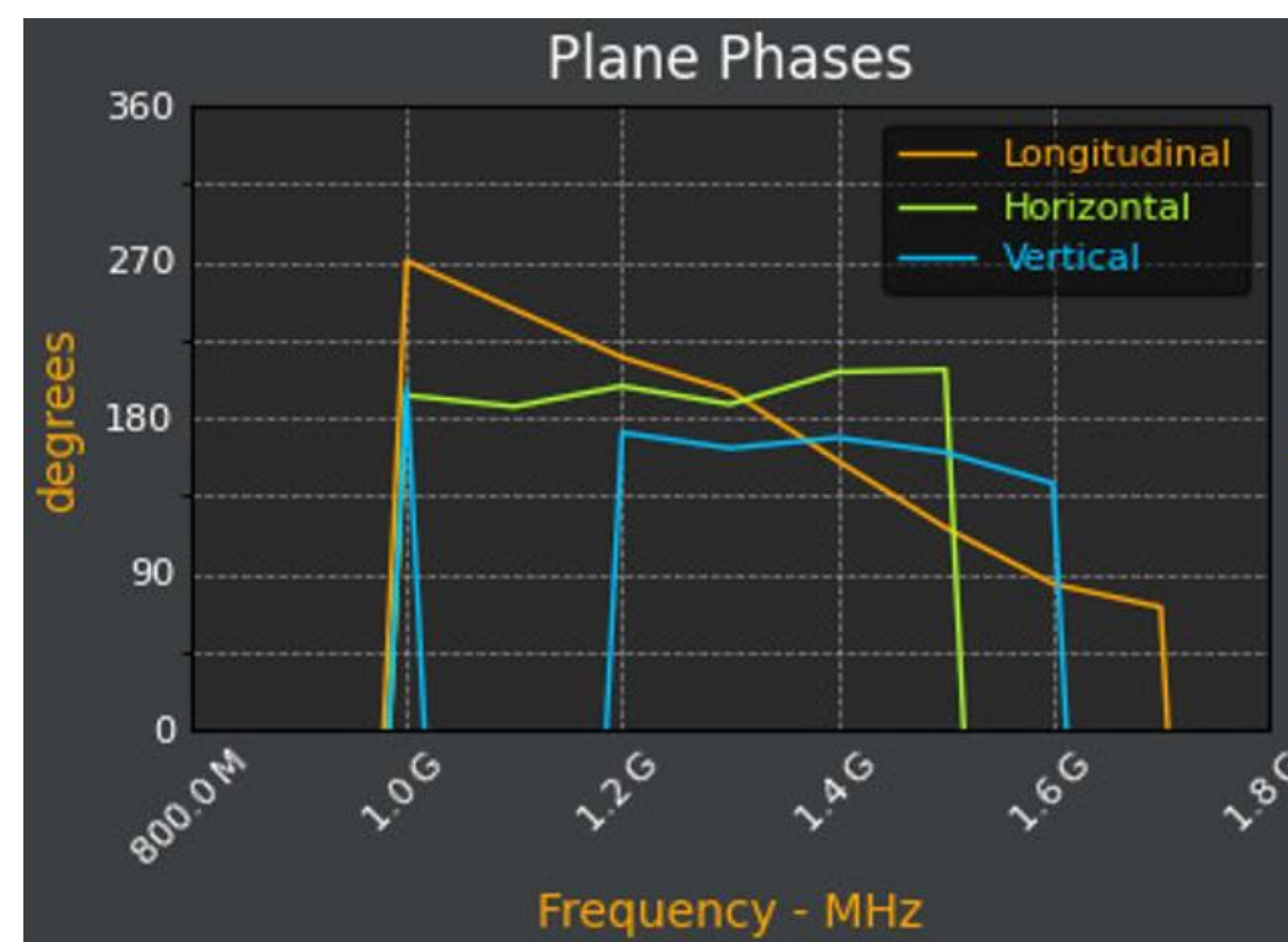

Figure 5 – 2.0 GeV/c BTF showing Longitudinal phase error

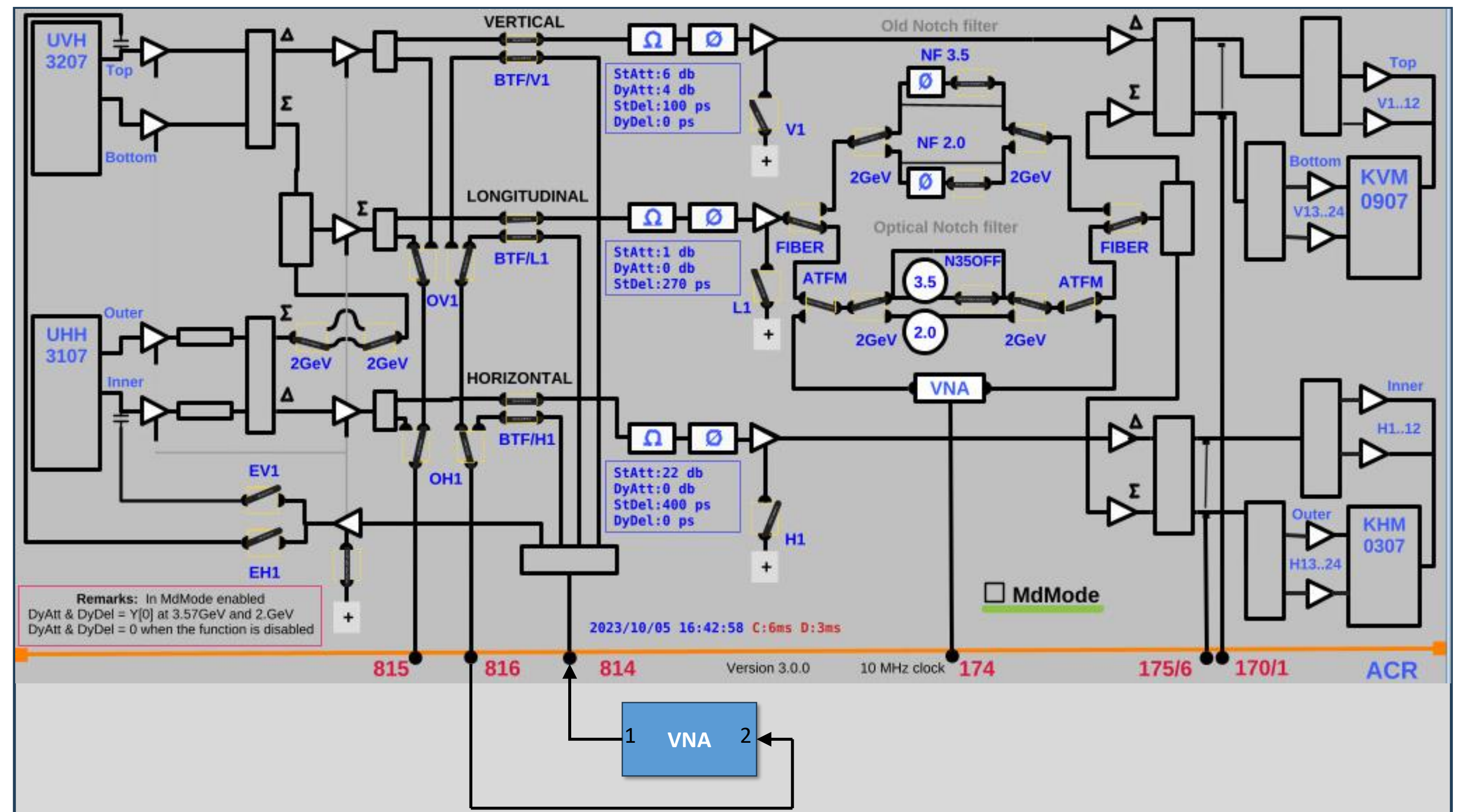

Figure 2 – BTF measurements synaptic

Beam Transfer Functions are performed with a Vector Network Analyzer located in the AD Control Room (Figure 2). During BTFs measurement the VNA output port is routed to the kickers KVM0907 and KHM0307 on the desired plan thanks to RF relays switching (BTF_V, BTF_L and BTF_H) and the receive port is connected to pickups UHH3107 and UVH3207 via OV1/OH1 relays. Longitudinal BTF is achieved with the notch filter disabled.

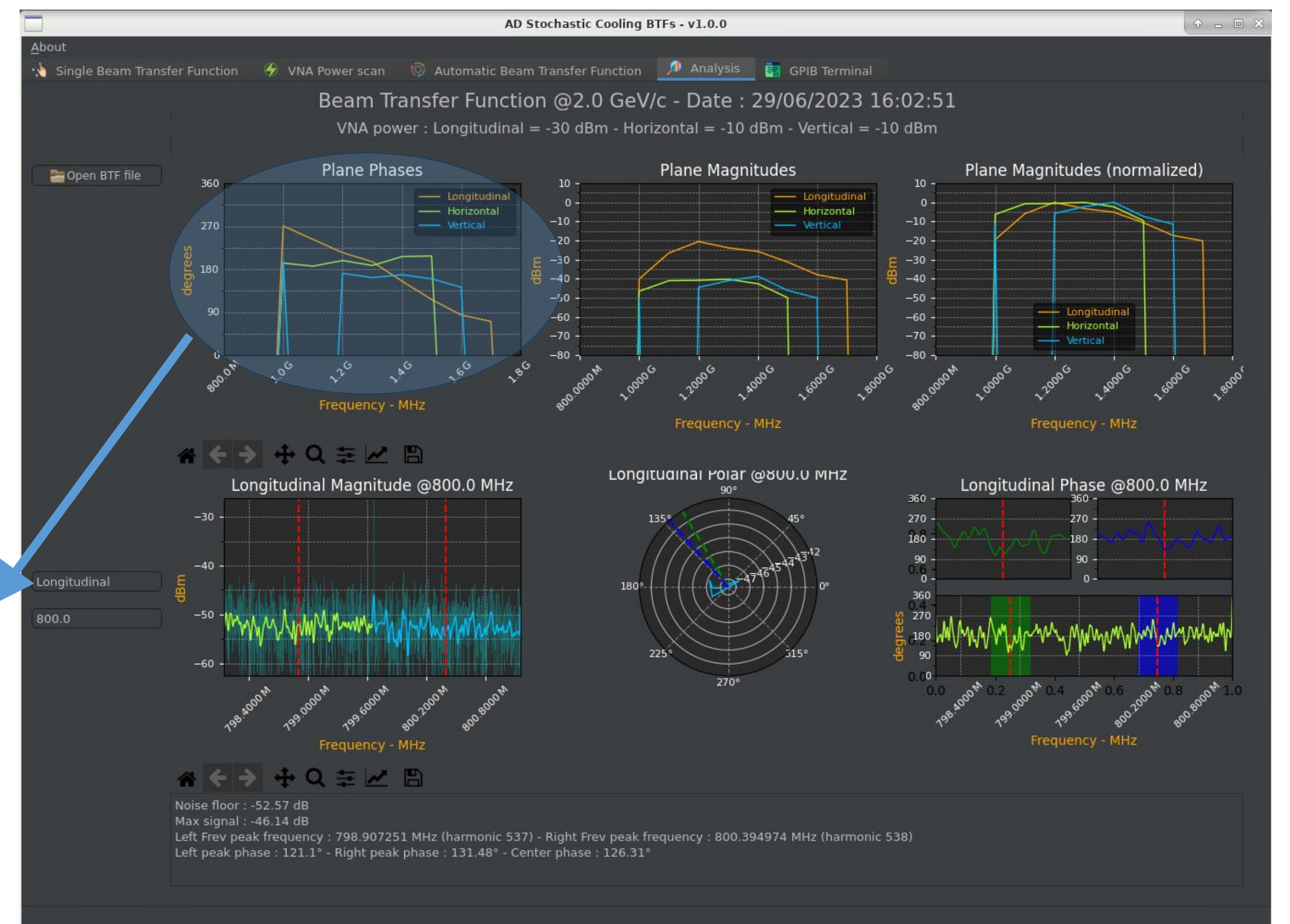

Figure 4 – Automated data analysis displaying measurement synthesis and enabling scrolling data

- Measured data are processed and displayed with the option to scroll through the data to retrieve specific frequency measurements.
- All the measurements taken are used to build magnitude and phase plots across the bandwidth.

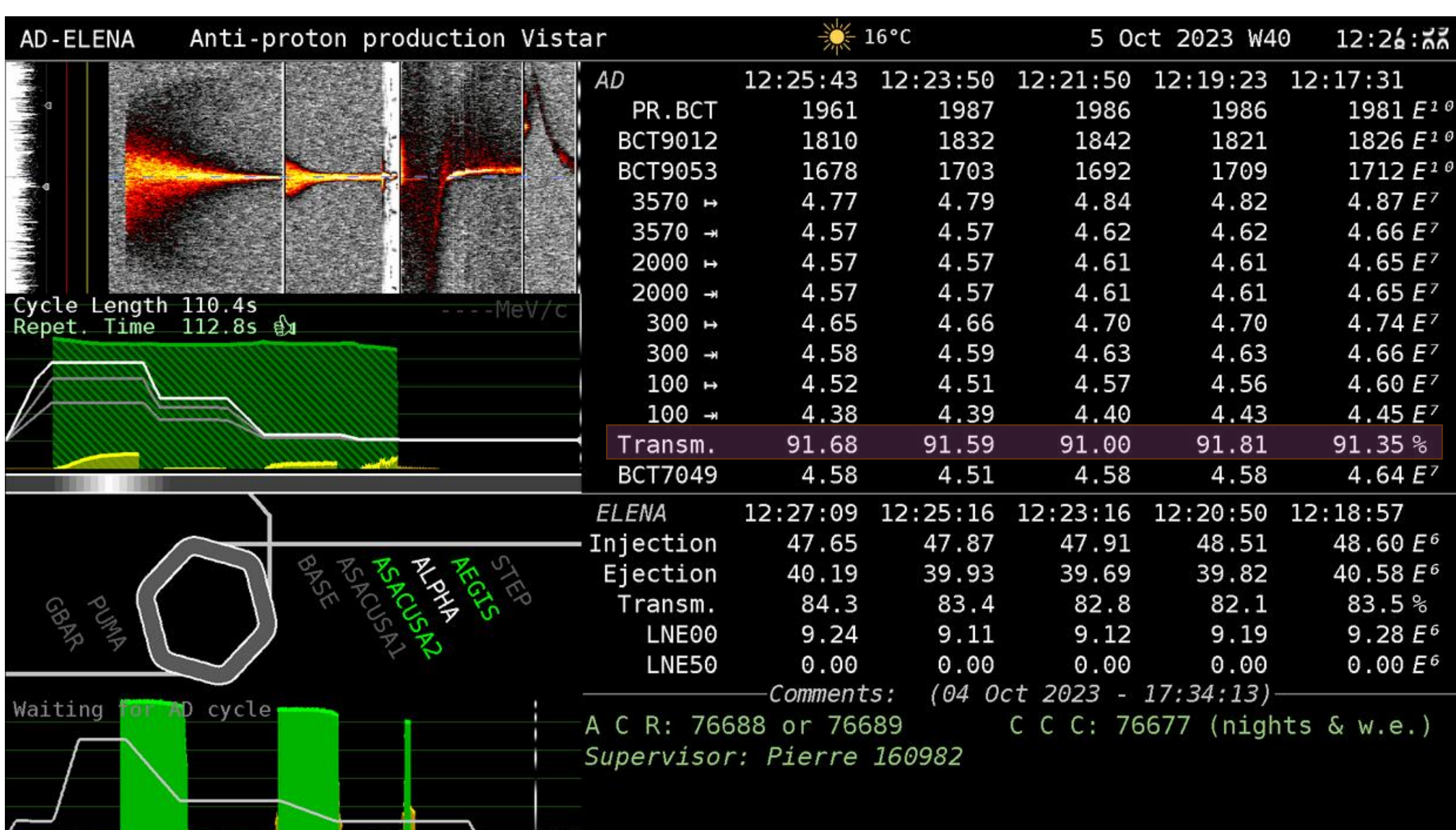

Figure 6 – AD Vistar showing 91% of energy transmission after correction

Beam Transfer Functions (BTF) require putting the AD into a dedicated 'pause' mode and keeping the beam at constant momentum.

- Beam circulates in the machine for extended period.
- Consequently, time slots available for BTFs are limited.
- Manual BTFs takes about two full working days for both plateaus to conduct, analyse and apply corrections.
- Little time is left for repeating measurements and making fine-tuning adjustments to the machine.

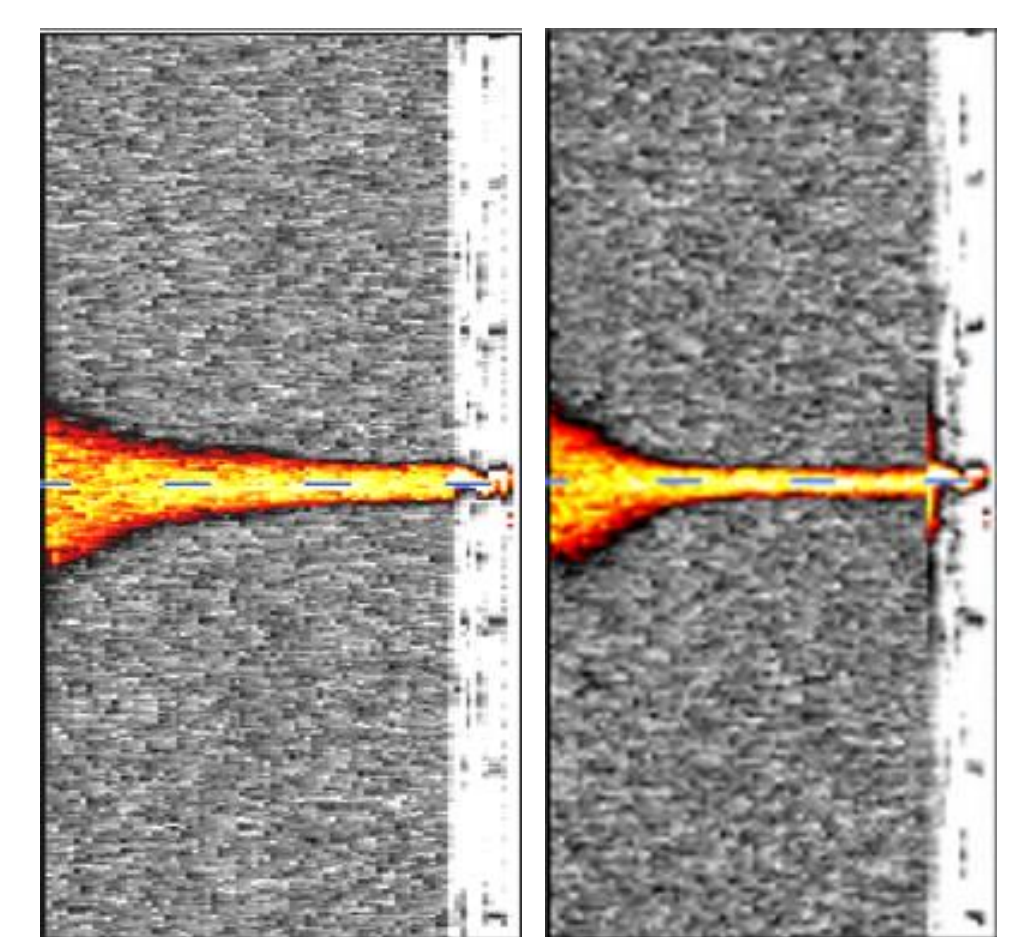

Figure 7 – 2.0 GeV/c before and after Longitudinal delay and phase correction

The BTF toolbox has enabled to :

- Reduce the measurement time, thereby increase the number of analysis iterations and machine adjustments.
- Shorten the 2.0 GeV/c plateau thanks to the cooling improvement (Figure 7) allowing to reduce the AD decelerating cycle time.
- Enhance the overall transmission by about 4%
- Significantly reduce the yearly commissioning time after the machine end of year technical stop.
- More anti-protons available for physics experiments.



Real Time
AD Vistar