



AIDAInnova WP10

3D printed ceramics

Martin Schwentenwein

A closer look at our LCM Technology

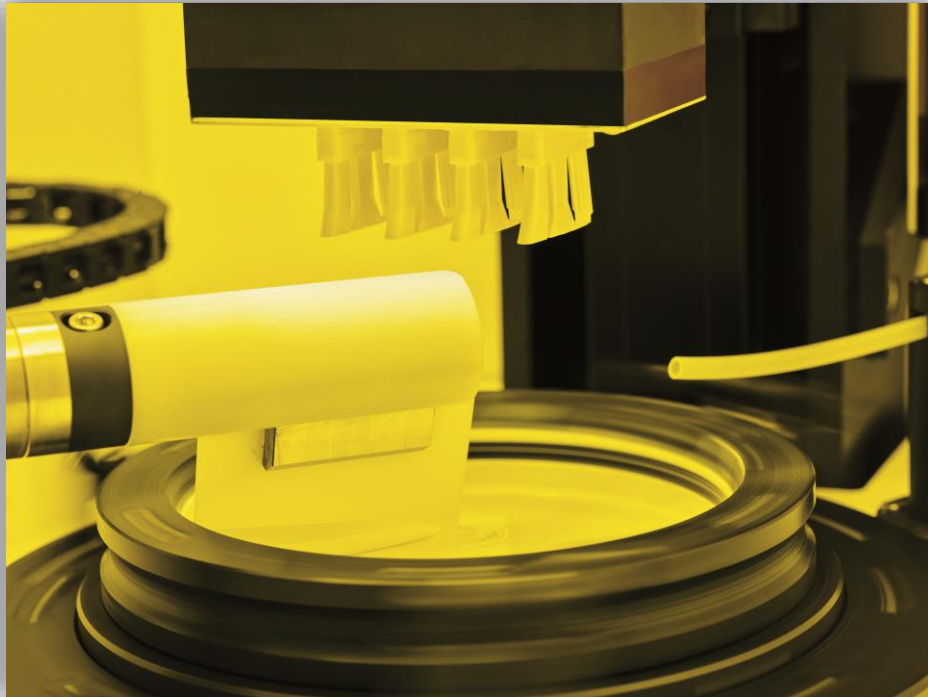

[Click to watch a video about the LCM technology](#)

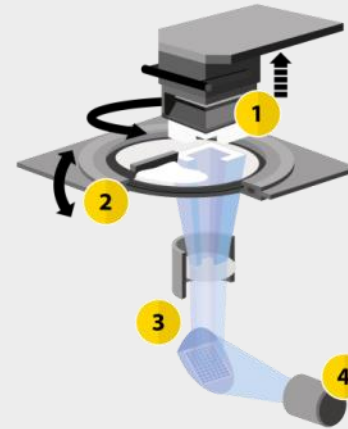

- 1 BUILDING PLATFORM
- 2 VAT
- 3 OPTICAL SYSTEM
- 4 LED

i Blue light cures the photosensitive formulation

Process Chain



CAD DESIGN



3D PRINT



DEBIND, SINTER



FINAL PRODUCT



Debind and Sinter Process

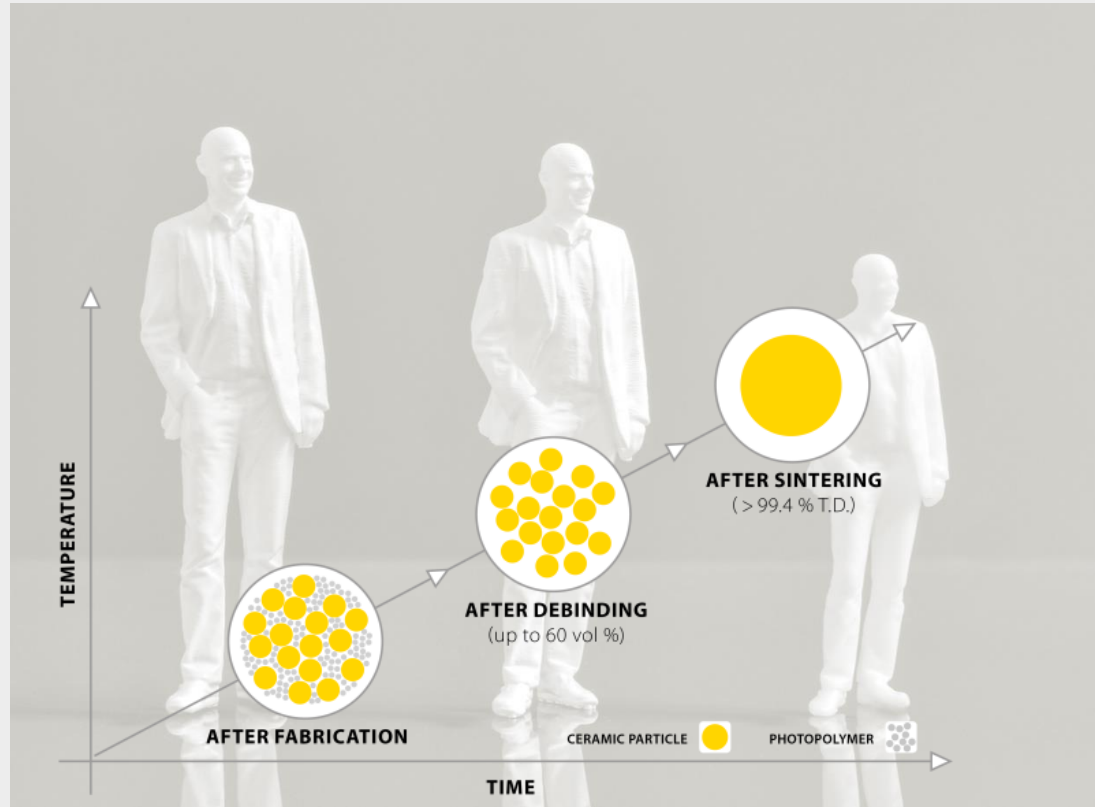



Aluminum oxide

ID	Material	Number of pieces	Type
E22447	Alumina	7	Plates
E22448	Alumina	7	Plates
A22352	Alumina	6	Discs
A22354	Alumina	9	Discs
A22353	Alumina	8	Discs
A22355	Alumina	7	Discs





Aluminum nitride

Aluminum Nitride

- High thermal conductivity
- CTE close to silicon

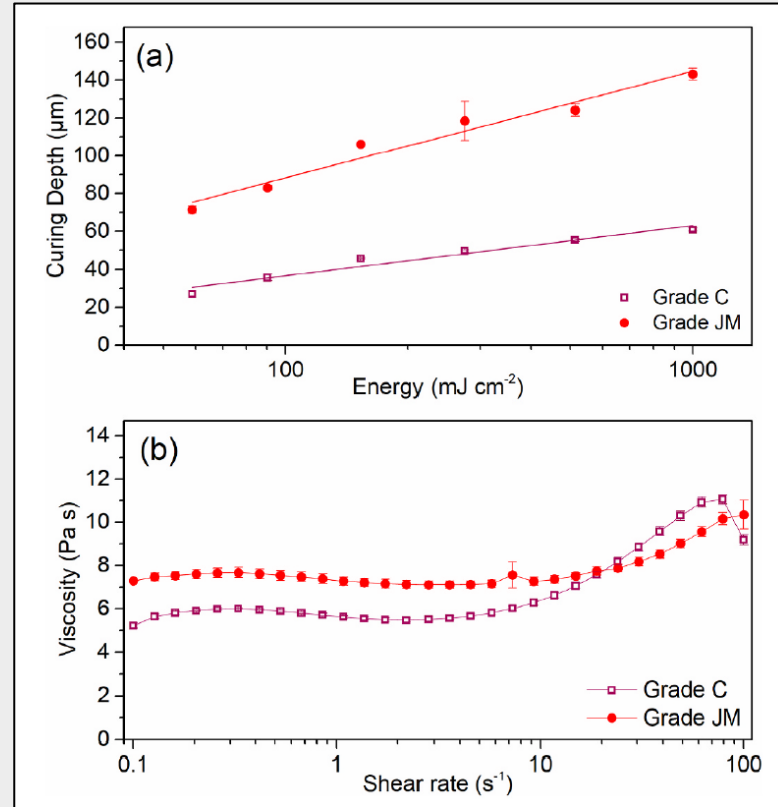

Aluminum Nitride

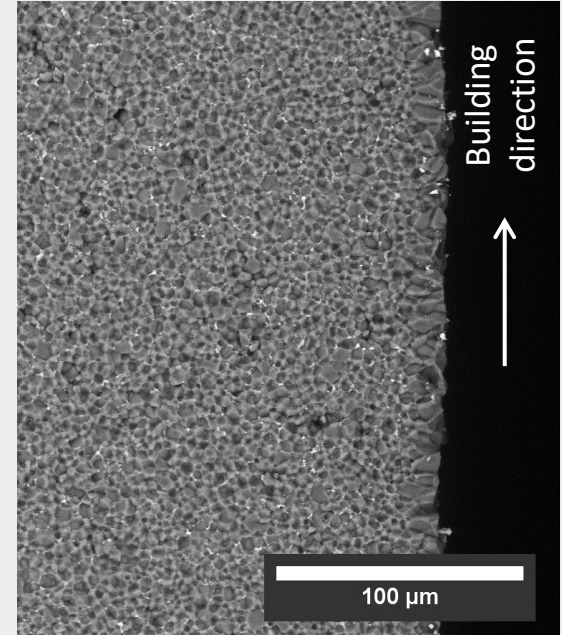
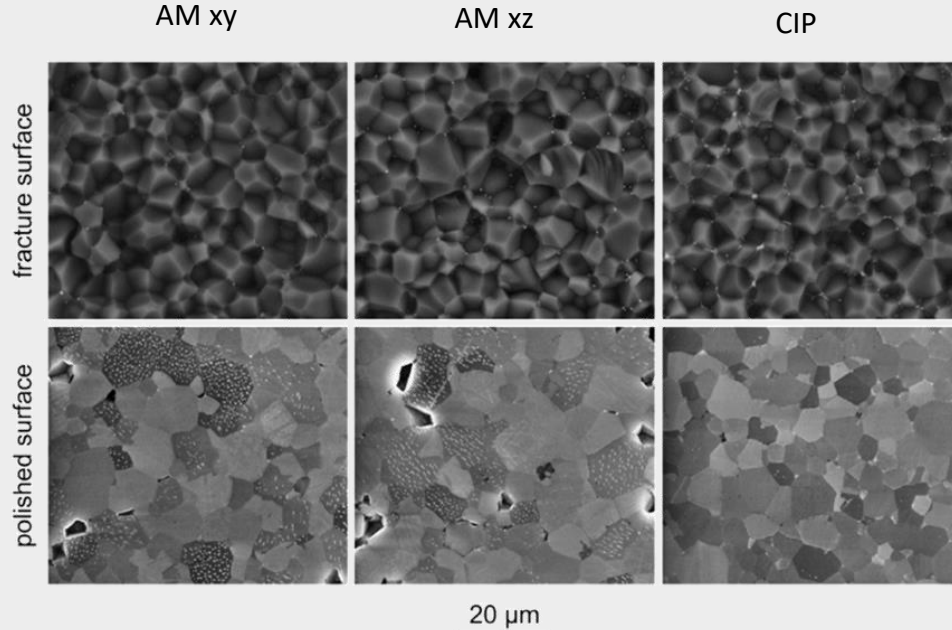
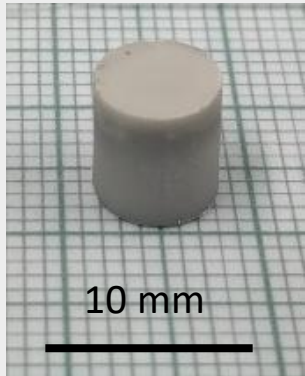

Aluminum Nitride

- complex shaped parts can be realized
- properties of AM materials comparable to conventionally produced parts

Property	CIP	AM
Relative density (%)*	> 97	> 96
Thermal conductivity (W/m.K)	170	169
Hardness (HV10)	960	940

* calculated reference value, expected to be higher in reality

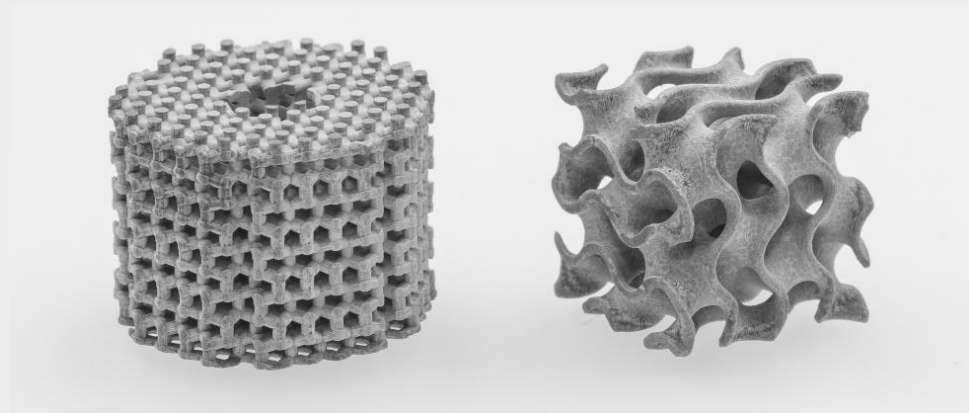

Discs, and cylinders

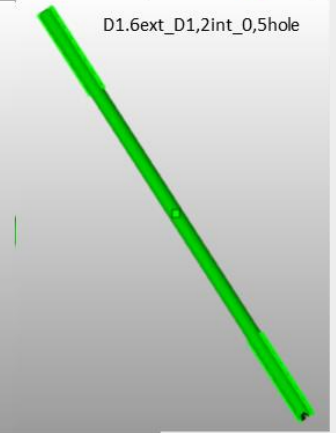
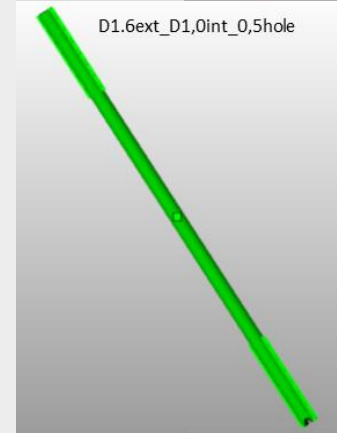
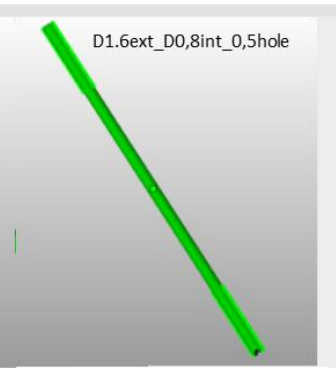
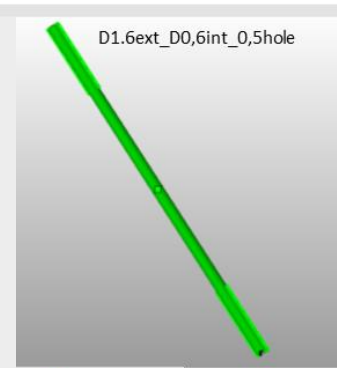
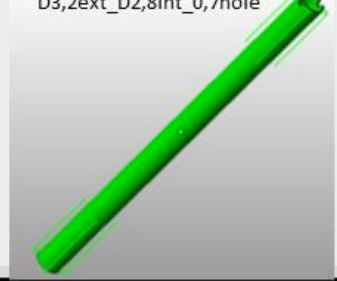
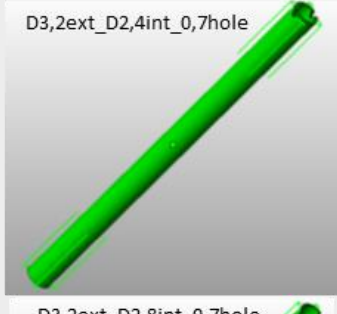
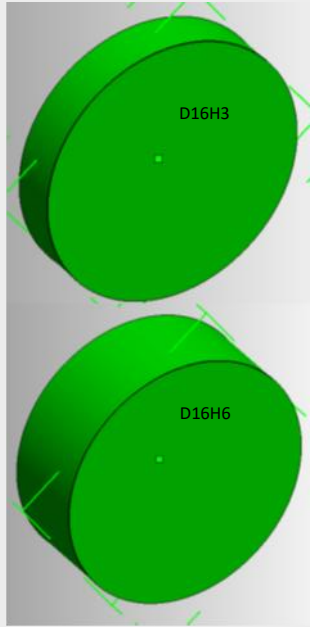

Cylinders were printed with notches at the bottom to avoid diving bell effect

Plates printed with different supports LITHOZ

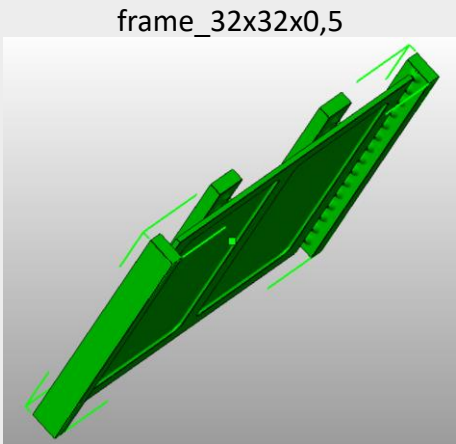
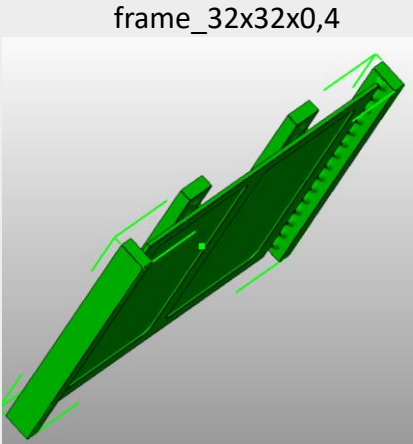
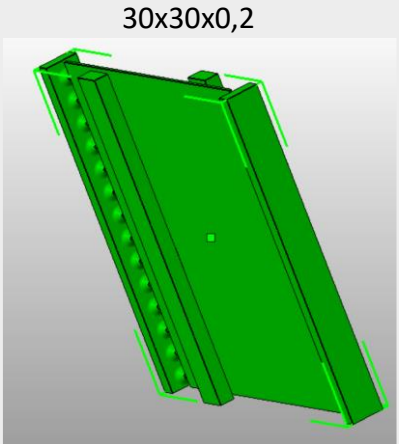
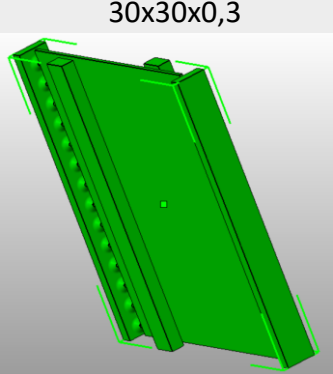
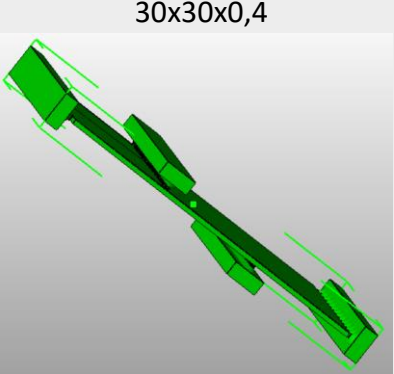
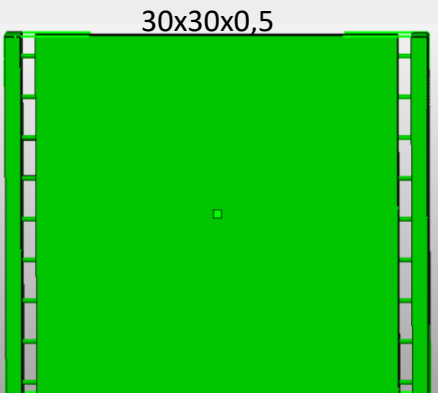
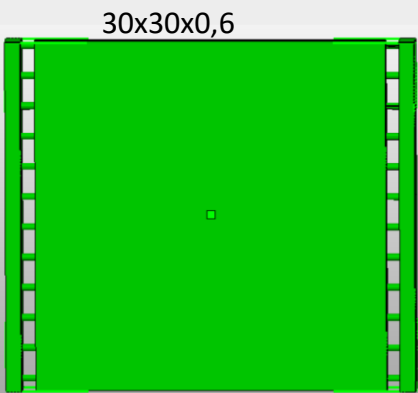

Aluminium Nitride

ID	Material	Number of pieces	Type
E22429	Aluminium Nitride	40	Test bars
E22461 & E22445	Aluminium Nitride	15	Discs D16H6
E22412B	Aluminium Nitride	15	Discs D16H3
E22276	Aluminium Nitride	11	Rods 1.6 mm
E22279	Aluminium Nitride	15	Rods 3.2 mm
E22404	Aluminium Nitride	15	Plates and Plate Frames

AlN

Density: 3,35g/cm³

Specific heat capacity: 740J/kgK

thermal conductivity 24°C

Probe 1: 212 W/mK

Probe 2: 213 W/mK

Probe 3: 213 W/mK

- density of 3.35gm/cm³
- Thermal conductivity: 212W/m.K
- Maximum wall thickness: 4mm
- Minimum wall thickness: 0.28mm
- Maximum Aspect ratio: 10
- Bending strength: 292.2 (+/-) 40MPa

Aluminium Nitride

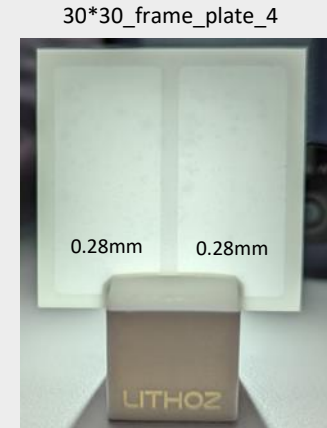

- Tailoring of formulation
- Optimization of sintering
 - density of 3.35 g/cm^3
 - Thermal conductivity: 212 W/m.K
(preliminary)
 - Maximum wall thickness: 4 mm
 - Minimum wall thickness: 0.2 mm
 - Maximum aspect ratio: 10
 - Bending strength: 360 mPa ($m = 10$)



200µm thin plate

Aluminium Nitride



Heat Exchanger

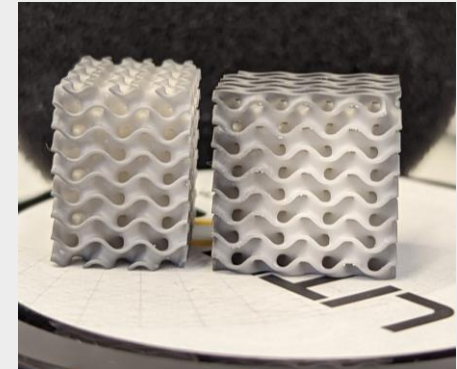
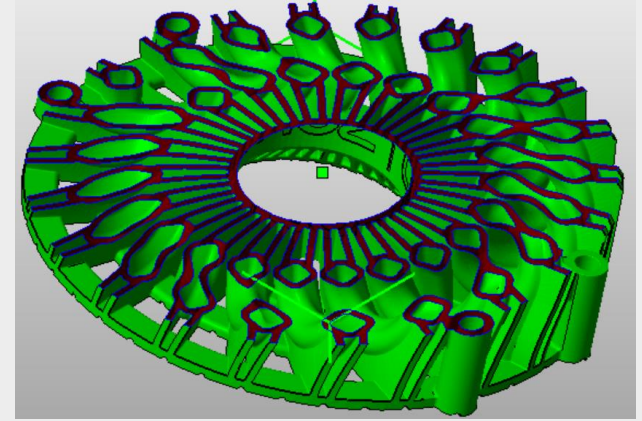

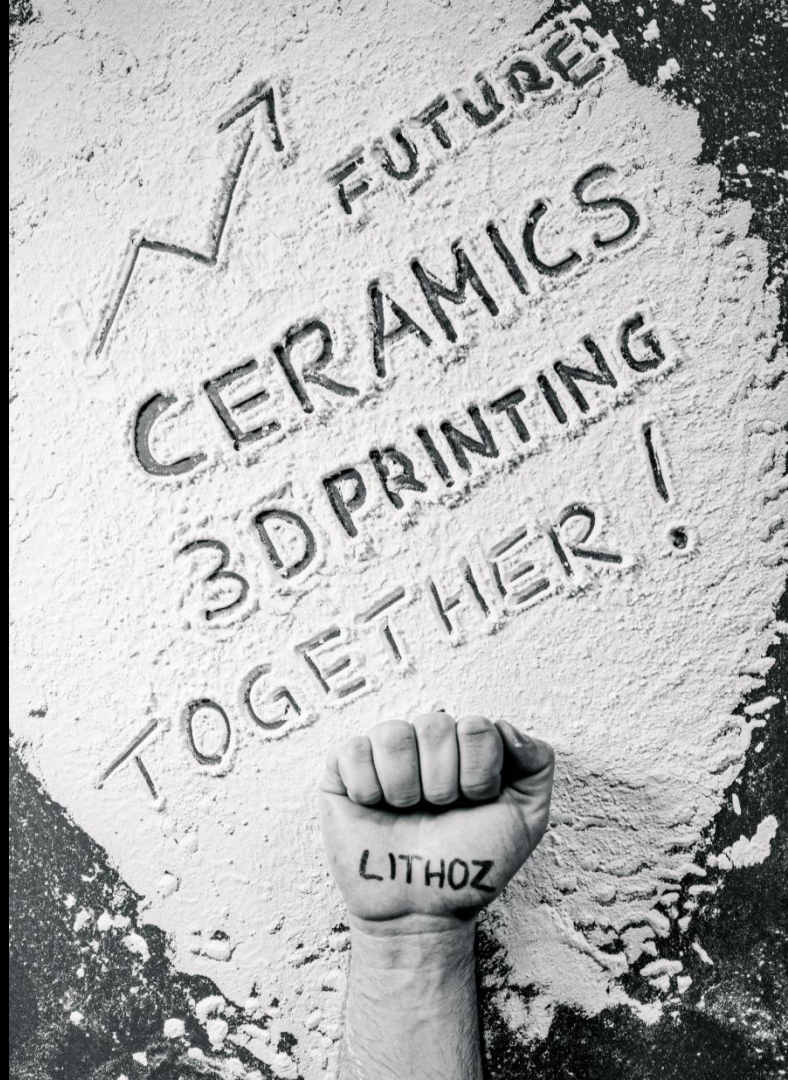

LITHOZ[®]

Manufacture the Future.

LITHOZ GmbH

Mollardgasse 85a/2/64-69

1060 Vienna/AUSTRIA

Phone: +43 1 9346612-204

mschwentenwein@lithoz.com

WWW.LITHOZ.COM