

Quality Control of the CMS Tracker and ECAL Installed Optical Cabling

D. Ricci, M. Abbas, S. Dris, K. Gill, R. Grabit, A. Jimenez Pacheco, L. Santos Amaral, V. Radicci, J. Troska, F. Vasey

CERN - European Organization for Nuclear Research, 1211 Geneva 23, Switzerland

Daniel.Ricci@pg.infn.it

Abstract

The readout and control optical links, developed for the CMS Tracker and ECAL at CERN, are approaching the final phase of the integration process at LHC Point 5. The individual component parts have been successfully integrated and connected at the innermost patch-panels. Efforts are concentrated on the multi-ribbon optical cable installation and connection to ribbon cables at the intermediate patch-panel inside CMS and to the racks at the patch-panel in the service cavern. Within the quality assurance programme, the quality control activities can give an online feedback during cable installation and provide an acceptance of the installed fibres. The final optical link lengths can also be measured as a precise input to the Tracker synchronization procedures. The recent integration experience and the quality control test system based on an Optical Time-Domain Reflectometer are described.

I. INTRODUCTION

The Compact Muon Solenoid (CMS) detector is currently undergoing its final integration phase at CERN LHC Point 5. Among several peculiarities it includes, to the best of our knowledge, the densest fibre optic system of its type in the world. The inner Silicon Strip Tracker [1] is read out and controlled by 39240 point-to-point optical links routed through three different patch panels: an inner (distributed) one, a dense (in-line) intermediate and a backend (distributed) patch panel. Similar optical links are used in the Pixel sub-detector, in the Electromagnetic Calorimeter (ECAL) and Preshower (about 15000 in total), as well as in MU-RPC (Muon Resistive Plate Chambers), BCM/PLT (Beam Conditions Monitor/Pixel Luminosity Telescope) and TOTEM systems. Figure 1 shows a schematic representation of the Tracker and ECAL optical links. A detailed description of these systems can be found in [2], [3] and [4].

The Optoelectronics Section of the CERN/PH department, has been historically responsible for designing the Tracker optical links (adopted further by the ECAL) and for procuring the optical components. Over the years, substantial efforts have been put in place to assess the link reliability [3], robustness [5] and, more recently, to define procedures and tools to assure and control their overall quality during the various integration activities.

The main features of the Quality Control (QC) program, the tools, the experience and the lessons learned in view of the forthcoming cabling of the Tracker and ECAL at Point 5 are described in the next paragraphs.

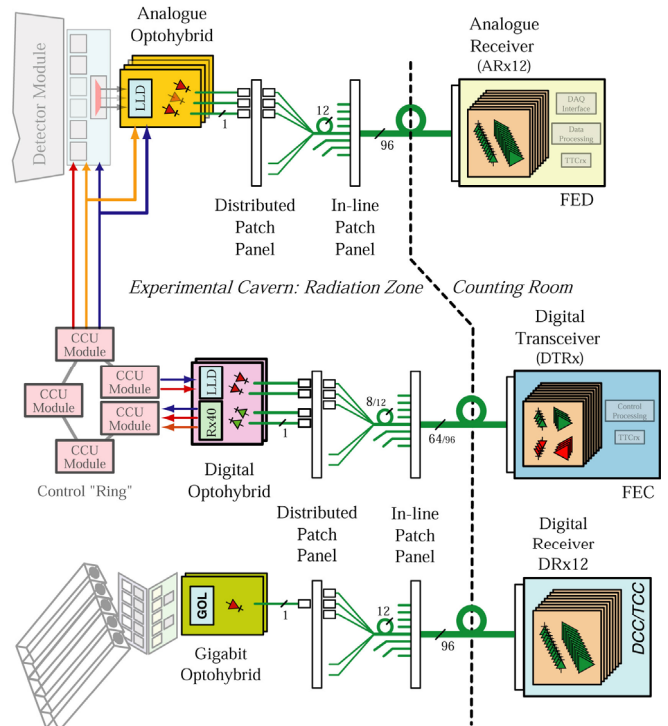

Figure 1: The Tracker Analogue readout (uppermost) and the ECAL Digital readout (lowermost) optical link system. The digital control link (in the middle) has the same design for both systems.

II. CABLING QUALITY CONTROL PROGRAM

In the CMS optical links the optical pigtailed fibres are routed individually inside the sub-detectors, fanned into 12-way ribbons (fan-outs) after the distributed patch-panel and then connected to 96-fibre dense Multi-Ribbon (MR) cables at the in-line patch-panel (PP1).

During the process of installation, routing and integration of the MR cables, acceptance and quality tests must be performed in order to validate the cable installation, give an assessment of the quality of the connections and measure the full optical link lengths, which are needed later for the synchronization of the Tracker [6]. To accomplish these tasks, a specific quality control procedure was defined.

A. Tracker

The QC program for the Tracker distinguishes two kinds of activities: systematic and troubleshooting. In Point 5 the MR cables will be tested in two steps to accept their installation and to validate their connection at PP1, measuring

also the overall lengths (test of the “full-link”). These activities are considered systematic and are carried out on 100% of the cables. For the MR cables, a comprehensive test campaign was already carried out in December 2006 at the Tracker Integration Facility (TIF) in preparation for the test on 20% of the detector. As troubleshooting activity, significant assistance was provided during the integration of pigtails and fan-outs on the various sub-detectors. During this activity, single fibres/connectors, ribbons and cables in full-link configuration were tested. The details of the lessons learned at the TIF are described further in section IV.

The test tool equipment for the link QC includes single-fibre fault locators (commercially available) and custom-built ribbon fault locators which work injecting visible light into the fibres to identify possible damaged points. These tools can also be used in combination with a camera or a microscope when the visual inspection of the fibres surface in a connector is required. In addition, a sophisticated test system based on a high-resolution Optical Time-Domain Reflectometer (OTDR) was developed for analytic fibre characterization and length measurement. The OTDR test setup is described in section III.

B. ECAL

The QC program for ECAL follows the same scheme as that of the Tracker. In this case, the MR cables are connected at PP1 before pulling them. A systematic test will be carried out to validate the quality of the installation procedures at the beginning of the cabling process. The tests on the full-links will be performed on the totality of the optical links. To this purpose, a second OTDR based test system was developed.

III. THE OTDR TEST SYSTEM

An Optical Time Domain Reflectometer (OTDR) is an instrument which allows the user to characterize the optical fibre under test by measuring, in terms of backscattered or reflected light, its response to a short optical impulse injected into it [7]. Given that the magnitude of the backscattered power is proportional, in any point, to the local transmitted power, the detected signal provides a detailed picture of the reflections along the fibre (caused by connectors, terminations, bends, splices, cracks, cuts, or any other non-homogeneity) as well as the local and distributed losses due to stress or strain. Providing the refraction index of the fibre, it is also possible to measure the time delay of the detected signal or, in other terms, the distance of the reflections from a reference point. The two main advantages of this technique are that it is not destructive and requires neither cutting the fibre nor access to both ends of it.

With respect to standard OTDR instruments, a Photon-Counting OTDR offers higher sensitivity and a much better spatial resolution (order of a few centimetres compared to the order of meters of the standard types) based on the fact that a single photon can be counted at a time. This type of instrument is suitable to measure optical networks spanning in the tens to hundreds of meter range as in the CMS optical links case. It is also worth mentioning that the Tracker synchronization procedure [6] requires a precision of 20cm for the overall optical link length, corresponding to a maximum error of 1ns (i.e. at most 4% signal loss) when

sampling the readout signal at the receiver in deconvolution mode. A high resolution instrument is therefore required to achieve such precision.

The instrument used for the quality control of the CMS cabling is a Sunrise (formerly Luciol) [8] Photon-Counting OTDR (ν -OTDR). The software was custom developed, accounting for the uniqueness of our optical system.

A. Optical switch configuration

Figure 2a depicts the setup used for testing a single CMS optical channel. The OTDR is connected to an optical switch which is controlled by software. This allows the possibility to sweep the 12 channels of a ribbon during the test. The switch is connected to a MR cable through a 12-fibre fan-out terminated with an MPO connector. This is called the launch lead. During the test of all links in a cable, the launch is connected to all 8 ribbons one at a time and the data from the single fibres are acquired and analyzed. It is essential that the launch connector be always kept in good condition and well cleaned to avoid the introduction of losses or scratches at the cable input.

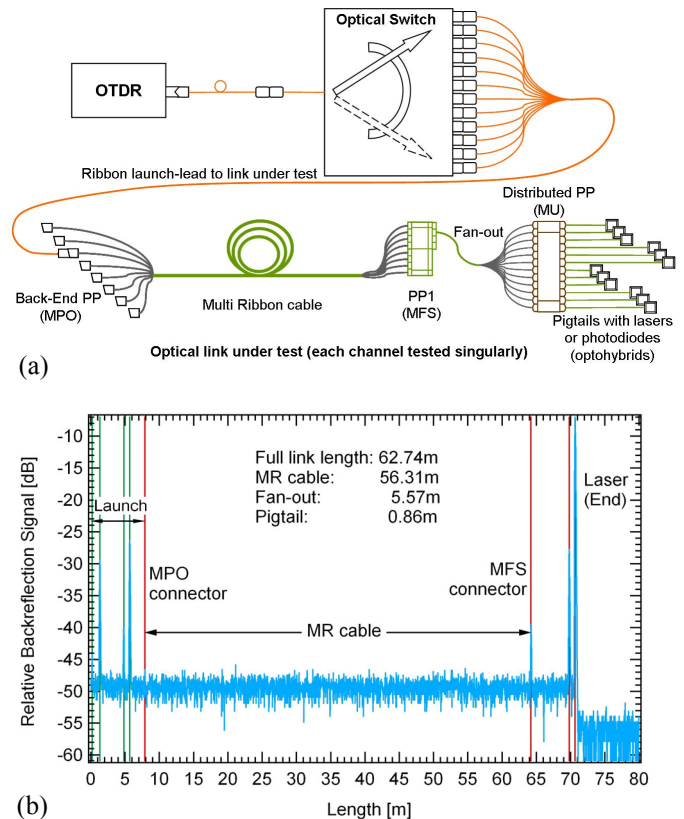

Figure 2: Test of a single optical channel with the OTDR combined to a switch (a) and the typical trace obtained (b) where the measured lengths are indicated.

The typical waveform measured is shown in figure 2b. On a distance scale, the peaks represent the reflections at the various components interface in the link. The peaks on the left hand side are from the launch connectors. It should be noted that the presence of a reflection at some point along the fibre does not imply necessarily the bad quality of a connection or the bad quality of the fibre itself. This can be only assessed by estimating the light-loss in that point, typically revealed by the presence of a step in the trace. In the event that a faulty

connection is suspected, the connectors can be cleaned and re-mated. When a loss is detected along the fibre, a replacement may be necessary. Knowing the launch length, the precise link length can be also determined. Based on the nominal lengths of the cables, additional and unexpected reflections can be automatically detected by the software comparing the measured peaks with the expected values.

The time required for testing an optical link with this method is 35s (including 25s of acquisition time and 10s for the cleaning/connection/disconnection of the launch) that brings the total test time for a MR cable to 56min (providing that no major problems are identified). As mentioned in [3] the time will be one of the major constraints during the installation activities and, although the test activity will be mostly in the shadow of the cabling process, the overall time required can still represent a handicap. For this reason, a faster system based on an optical splitter was developed.

B. Optical splitter configuration

Figure 3a shows the setup configuration in which the optical switch has been replaced by a custom made optical splitter. The 12 arms of the splitter have been fusion spliced with fibres of staggered lengths coming together in a ribbon terminated with an MPO connector (launch-lead). The configuration allows the separation of the reflection peaks of the 12 single fibre traces during a simultaneous measurement (figure 3b).

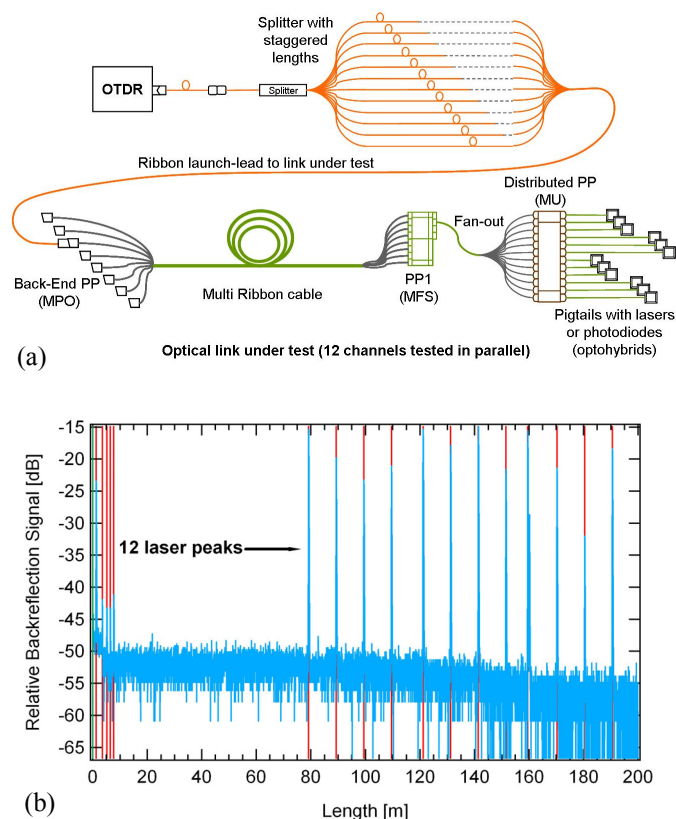

Figure 3: OTDR in the optical splitter configuration (a). The typical trace for a full-link (b) exhibits 12 peaks corresponding to the reflections of the laser diodes at the end of the links in a ribbon. Vertical cursors in the trace represent the software peak detections.

This method downs by a factor 3 the time of measurement bringing it to 19min per cable. At this point, the dominant component of the overall time needed is the time for cleaning and mating the launch/cable connectors.

The splitter setup will be used for the tests of the MR cables and full links in P5, even though it is not meant to replace completely the switch-based method. The latter is useful to evaluate the details of a single channel and it will continue to be used for the troubleshooting activities, in particular when results from a test with the splitter are dubious or unclear.

The overall lengths measured with both setups have a precision of ± 10 cm with respect to the physical length of the fibres under test.

IV. EXPERIENCE AND RESULTS

A. Integration of the Tracker sub-detectors

At the time of the integration of the various Tracker sub-detectors at the TIF, the quality of the optical chain was systematically checked by the Data Acquisition (DAQ) and a more detailed analysis with optical instruments was required only in dubious cases. The use of the OTDR for checking the distributed patch panel was limited to the few cases of broken fibres to determine precisely the break position in order to evaluate a possible repair action. In the other cases, a visual inspection (with a microscope) of the MU connectors ferrule surface was preferred. In almost all the dubious cases inspected (38 out of 41) the inspection revealed that the surface was quite dirty (see Figure 4). Functionality was completely recovered after cleaning. In three cases the surface was found to be scratched, resulting in a reduction of the overall link gain.

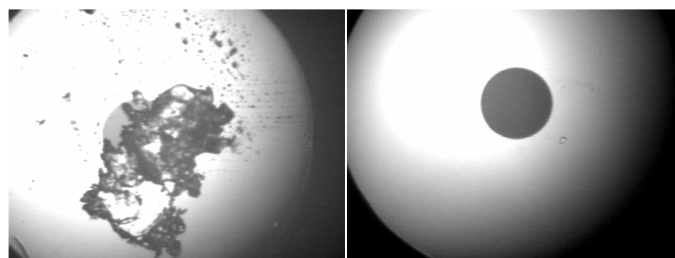

Figure 4: Microscope view of an MU connector ferrule (1.25mm diameter) before (left) and after (right) cleaning.

The troubleshooting activity, with the OTDR in the switch configuration, was carried out on 68 fan-outs during their installation at the distributed patch panel on both Tracker edges. All of the tested fan-outs were found to be good (in the worst case the problem was limited to a heavy scratch on the protective coating). Three more fan-outs, found to be broken during visual inspection, had to be cut and spliced with a new connector.

Table 1 provides the summary of all the optical parts installed in the CMS Tracker, including the quantity of the MR cables to be installed in P5 at the end of September 2007.

Table 1: Silicon Strip Tracker: installed optical parts.

Optical parts	Total installed	Installed optical fibers	Broken fibers	Faulty fibers
Analogue optohybrid	15148	36392	19	18
Digital optohybrid	712	2848	0	0
Fan-out	3624	43488	41*	0
MR	530**	50880	<i>Installation pending</i>	

* fibres in fan-outs were re-routed with no impact on the system performance.

** 34 additional cables for Pixel sub-detector will be installed and tested at the same time.

The “broken fibres” in the Analogue Optohybrid line of the table correspond to optical channels lost (not accessible for repair), whilst “faulty fibres” correspond to channels functioning at very low gain (less than 20% of the target), which cannot be compensated for by varying the Linear Laser Driver gain [2]. This is due to various reasons, including: poorly mated or dirty MU connectors, over bending of the fibres, low efficiency of the lasers (less likely) or to a combination of these factors.

B. Tracker Integration Facility cabling

After completing the integration of its sub-detectors, 20% of the Tracker has been tested extensively. For this purpose, 101 optical MR cables were temporarily installed and integrated into the readout and control system structure in November 2006. The cables were a mix of 50m and 55m nominal length for a path of about 20m. The slack was arranged on the roof of the TIF and in the adjacent cold room in special structures, purposely developed for coiling the excess length in a natural 8-shape (reducing to a minimum the stress on the stack of ribbons inside the MR cable). On the front-end side, the cables were routed and connected on temporary structures placed on the edge of the Tracker; 5 cables were also connected in a final version of the PP1 cassette [3] to verify the final connection and routing in the patch panel. On the back-end side, the cables were installed in the final patch panels and connected to the FED and FEC cards by the cabling team.

According to the Quality Control procedures, a first systematic OTDR test (splitter version) was performed on all the MR cables before their connection to the fan-outs at the front-end. No failure was found in this phase, therefore validating the good quality of the installation procedure. In only two cases (i.e. two fibres) a very low reflection at the MFS connector end required an in-depth test with the switch to verify the absence of defects. Additionally, the length of each cable was measured and stored for use as reference values in the subsequent full-link tests.

Figure 5 shows, as a typical example, the distribution of the lengths measured for the first (the longest) ribbon of the 55m long cables.

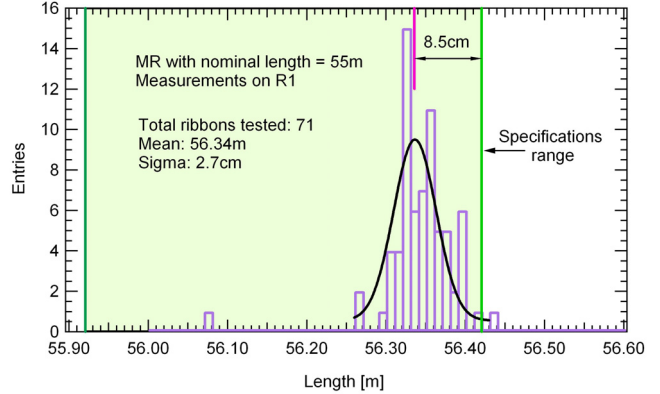

Figure 5: Distribution of the MR cable measured lengths (first ribbon of each cable). Similar results were obtained for the other ribbons. The real MR cable length equals to the sum of the nominal length, the naked ribbon length (not included in the nominal) and the tolerance allowed.

The measured lengths are given with an error of ± 10 cm including, as the main limitation to the precision, the variation of the absolute position of the launch reflection used as reference during the calibration of the system. This phenomenon is due to the adjustment of the dynamic range of the instrument relative to the amplitude of the reflected peaks. An evaluation of the single traces suggests indeed that for the MR cables (where the typical strong reflections of the full-links are not present) 90% of the lengths measured approach the actual physical lengths with an accuracy of better than ± 4 cm.

C. TIF full optical links

After connecting all the cables at the front-end, the full optical links were tested with the DAQ and checked with the OTDR when there was a suspicion of a bad connection. The final assessment on the links quality was thus given by a combination of the DAQ and the OTDR results. 16 MR cables (408 full-links in total) were investigated, yielding 13 dirty connections at PP1 and 3 at the back-end patch panel. In all cases to clean the connectors fully recovered performance. In three more cases, the OTDR analysis identified a problem with the fibre pigtailed inside the structure: on two fibres, over bending induced a loss not recoverable by increasing the nominal link gain; the third fibre had an interruption at the MU connector (either MU disconnected or fibre broken on the connector edge).

In response to the above three problems identified at the back-end, a visual inspection with the microscope was performed on 32 additional connectors at the back end, including the surface of the NGK connector inside the FED cards. All connectors were found to be clean.

D. ECAL troubleshooting

To date, all the interventions on the ECAL optical links have been limited to troubleshooting 668 fibre channels. During the Barrel super-module installation, 65 fan-outs were tested with the OTDR in the switch configuration and 15 more ribbons were tested on the End-cap structure. In the Barrel case, damage to the ribbons close to the edge of the

detector was suspected. A thorough OTDR analysis indicated that the optical links were well connected without excessive losses in the link. One control ring however functioned intermittently. The combination of the DAQ tests with the OTDR measurements on that control ring lead to the decision to replace the control board. In the End-cap case, out of 15 ribbons tested, 7 were found physically broken and were subsequently repaired (splicing).

During the abovementioned tests, the OTDR was connected at the ECAL in-line patch-panel except in one case where the test was performed at the back-end, after the DAQ test, with a temporary cable of 125m length. The measured links were good but the analysis revealed a stress in the cable about 20m before the patch panel. A subsequent visual inspection revealed an excessive bend in the cable; a clear lesson to be learned for the future installation process.

V. OUTLOOK FOR P5

The commissioning test of 20% of the Tracker ended in July 2007. In August, all the MR cables were removed and all the fan-outs were grouped according to their destination in the PP1 cassettes and properly arranged along the edges of the Tracker.

The dismantled MR cables were systematically tested with a fault locator (light box) and a microscope, using the OTDR for the investigation of 8 dubious cables. All cables were found to be good, further validating the quality of the procedure adopted for dismantling. The 530 MR cables for P5 (including the new ones) were also equipped with final protections and rearranged in their boxes to minimize the space requirement and the time of operation at P5.

The MR cable tests at P5 will be performed in parallel with the installation, allowing the possibility to replace a cable if it is found broken¹. In contrast, during the full link tests, problems can be solved only over 2m of ribbon accessible before PP1 where, having enough space, a splice can still be made. Every anomaly identified beyond that point and inside the detector can only be flagged as future reference for the DAQ system.

VI. CONCLUSION

In the framework of the optical cabling activities for the CMS Tracker and ECAL detectors, Quality Control procedures were defined and extensively practiced. The set of test tools, purposely developed, includes different instruments for visual inspection and a sophisticated, custom-developed, OTDR-based system.

At the Tracker Integration Facility at CERN, the QA/QC procedures were practiced during the installation/removal of 101 MR cables for the 20% test of the Tracker and their connections/disconnections to the patch-panels. The troubleshooting activities (during the sub-detectors integration and commissioning) provided essential support to the people involved and allowed us to practice/tune the test tools.

The TIF results are very encouraging: the QA procedures did not reveal any failure in the cabling process; 87% of the 41 channels classified as problematic by the DAQ were fully recovered as well as 100% of the problems on the connections at PP1. In general, the OTDR is able to flag the optical channels that will be problematic to the DAQ analysis and, in the dubious cases, a combination of the DAQ and OTDR results allows a clear determination of the channel functionality.

As a general remark, the cleanliness of connectors continues to be one of the main issues. Experience indicates that many problems that appeared during integration/commissioning were due to dirty connectors and were solvable in almost all cases. Practicing with a variety of cleaning tools for the cables and the receiver connectors yielded good results at the TIF. These proven cleaning methods will certainly be applied at P5.

In conclusion, the QC procedures and tools are now well defined for the upcoming installation and integration of the optical cables at Point 5.

ACKNOWLEDGEMENTS

Authors wish to thank all the people who collaborated on the described activities, in particular, the technical staff of the PH/ESE/BE and PH/CMT groups and the University of Minnesota group for the activities on the ECAL.

REFERENCES

- [1] CMS Tracker Technical Design Report, CERN/LHCC 98-6, Apr. 1998 and Addendum to the CMS Tracker TDR, CERN/LHCC 2000-016, Feb. 2000.
- [2] Jan Troska et al. "Optical Readout and Control Systems for the CMS Tracker", IEEE Transactions on Nuclear Science vol.50 n.4, pp. 1067-1072, Aug. 2003.
- [3] K. Gill et al. "Integration of CMS Tracker Optical Links", Proceedings of 12th LECC Workshop, Valencia, September 2006.
- [4] J. Troska et al. "CMS Optical Links – Lessons learned from Mass Production", Proceedings of 12th LECC Workshop, Valencia, September 2006.
- [5] Karl Gill et al. "Radiation Hardness Qualification of InGaAsP/InP 1310-nm Lasers for the CMS Tracker Optical Links", IEEE Transaction on Nuclear Science, vol.49, n.6, Dec. 2002.
- [6] K. Gill et al. "Synchronization of the CMS Tacker", Proceedings of 9th LECC Workshop, Amsterdam, October 2003.
- [7] M. K. Barnoski et al. "Optical time domain reflectometer", Applied Optics Vol. 16 No.9, September 1977.
- [8] Sunrise Telecom web-page: <http://www.sunrisetelecom.com/>
- [9] CMS Tracker optical links web-page: www.cern.ch/cms-tk-opto

¹ It is not excluded to keep a broken cable in place if other ribbons can be used instead of the damaged one(s).