

Radiation-Hard Optical Link for SLHC

W. Fernando, K.K. Gan, A. Law, H.P. Kagan, R.D. Kass, A. Rau, S. Smith
The Ohio State University

M.R.M. Lebbai, P.L. Skubic
University of Oklahoma

B. Abi, F. Rizatdinova
Oklahoma State University

September 4, 2007



Outline



- Introduction
- Bandwidth of micro twisted-pair cables
- Radiation hardness of PIN/VCSEL arrays
- Results on MT-style optical packages based on BeO
- Summary



ATLAS Pixel Opto-Link Architecture

- ATLAS is a detector studying pp collisions of 14 TeV at CERN
 - ◆ pixel detector is innermost tracker
 - ◆ detector upgrade planned for Super-LHC in 2015

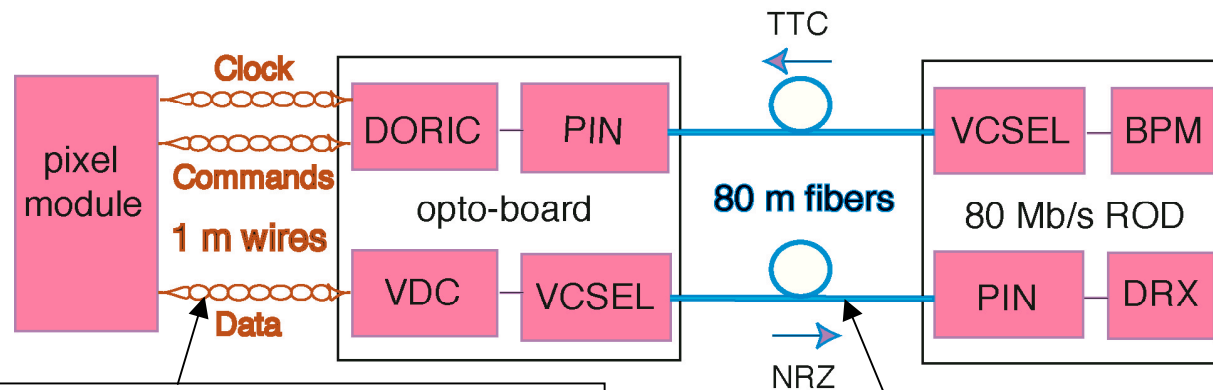

micro twisted pairs decouple pixel and opto module
⇒ simplify both design/production

8 m of rad-hard/low-bandwidth SIMM fiber fusion spliced to 70 m rad-tolerant/medium-bandwidth GRIN fiber

- ⇒ upgrade based on current pixel link architecture to take advantage of R&D effort and production experience?



R&D Issues for SLHC



- bandwidth of ~ 1 Gb/s is needed
 - ◆ can micro twisted pair transmit at this speed?
 - ◆ can fusion spliced SIMM/GRIN fiber transmit at this speed?
 - ✓ measured bandwidth ~ 2 Gb/s (see LECC06 talk)
- can PIN/VCSEL arrays survive SLHC radiation dosage?



Bandwidth of Micro Twisted Pairs

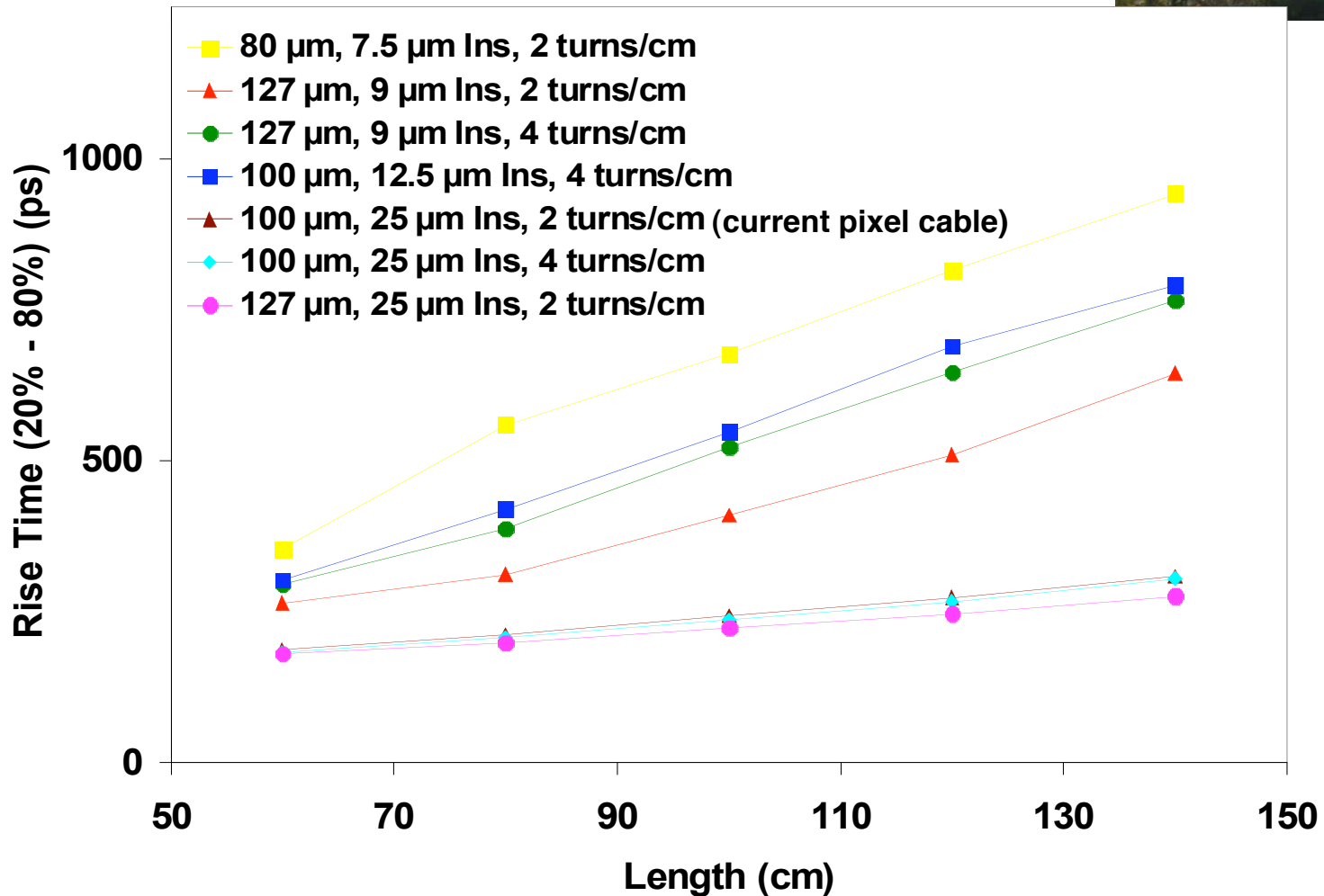
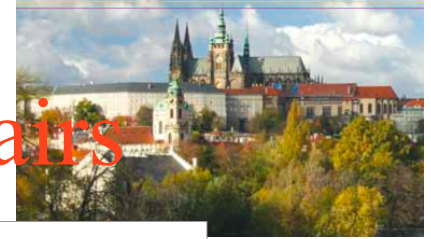

● current pixel cable with thick insulation is quite optimum!



Eye Diagrams

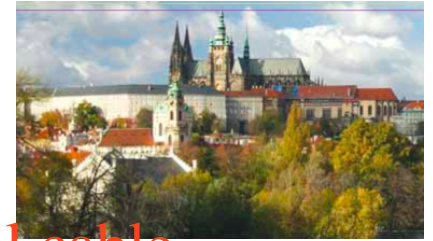

127 μm cable
140 cm

100 μm current pixel cable
140 cm
60 cm

640 Mb/s

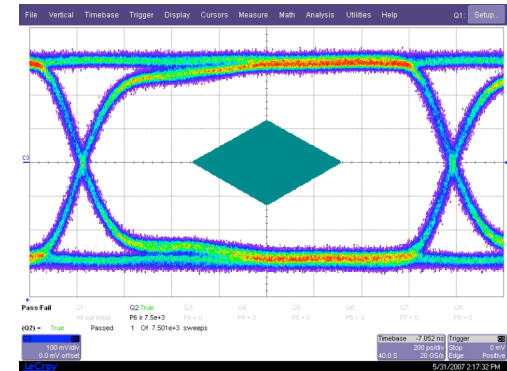
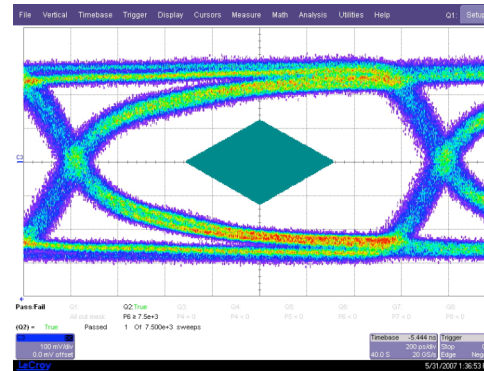
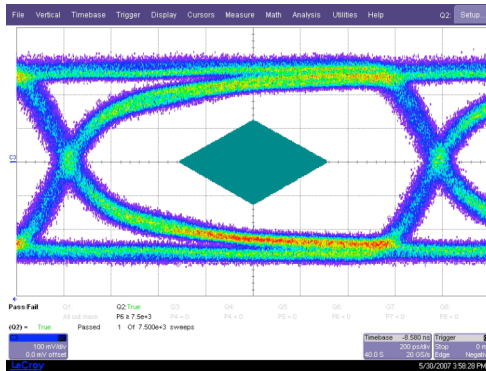

1280 Mb/s

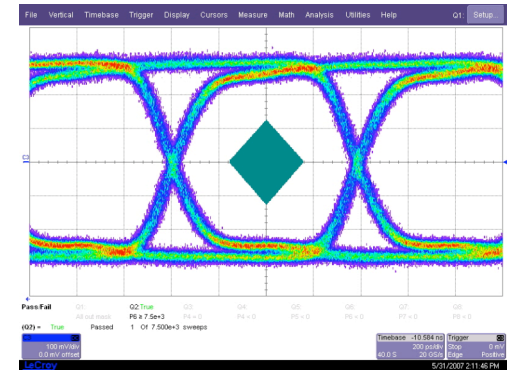
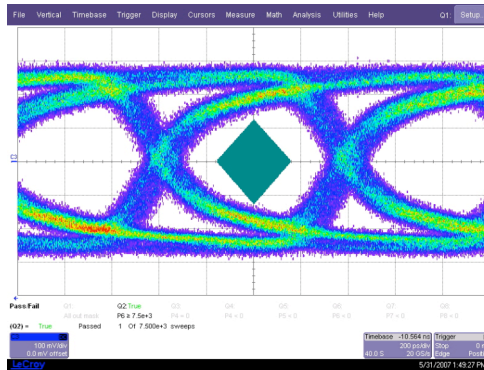
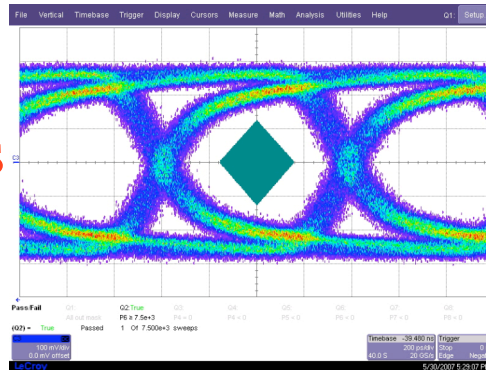

- transmission at 640 Mb/s is adequate
- transmission at 1280 Mb/s may be acceptable
- 127 μm cable is slightly better



Radiation Level at SLHC



- Optical link of current pixel detector is mounted on patch panels:
 - ⇒ much reduced radiation level:
 - ◆ Si (PIN) @ SLHC (5,000 fb⁻¹):
 - 2.5×10^{15} 1-MeV n_{eq}/cm^2
 - 4.3×10^{15} p/cm² or 114 Mrad for 24 GeV protons
 - ◆ GaAs (VCSEL) @ SLHC:
 - 14×10^{15} 1-MeV n_{eq}/cm^2
 - 2.7×10^{15} p/cm² or 59 Mrad for 24 GeV protons
 - ◆ above estimates include 50% safety margin



PIN Responsivity

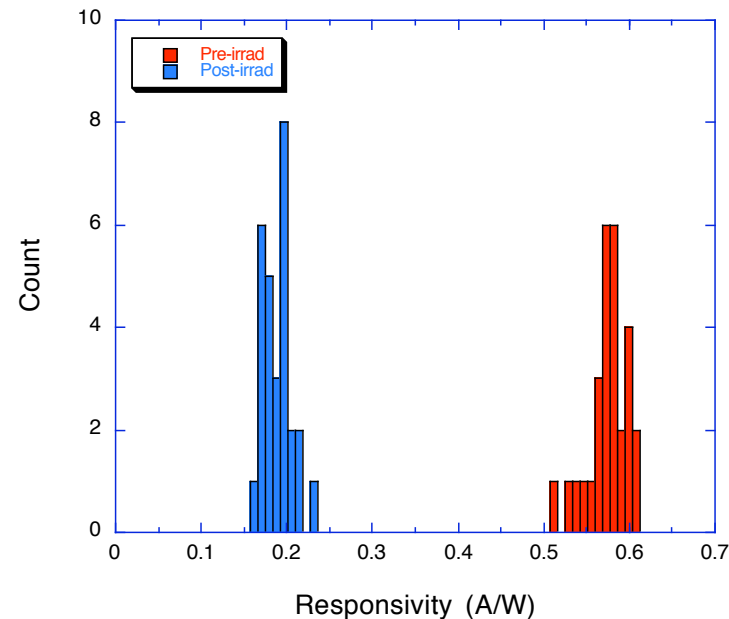
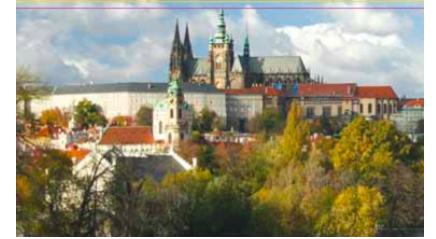

- Si PIN responsivity decreases by 65% after SLHC dosage
- completed irradiation of GaAs PIN from 3 vendors:
 - Optowell, AOC, ULM
 - responsivities will be measured next month



VCSEL LIV Characteristics

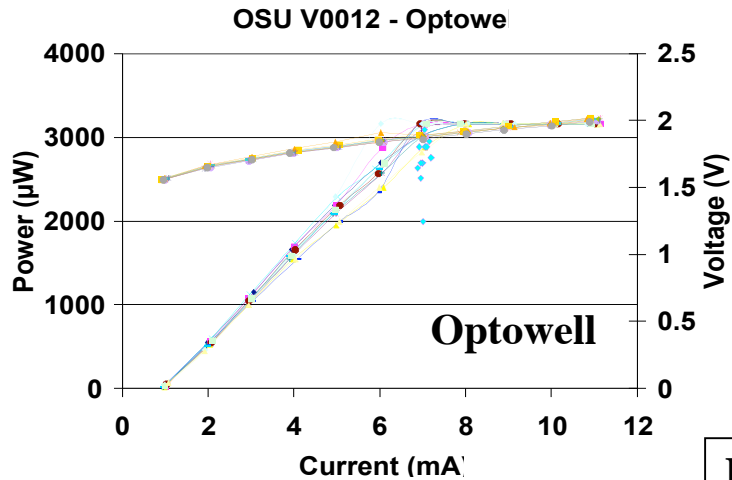
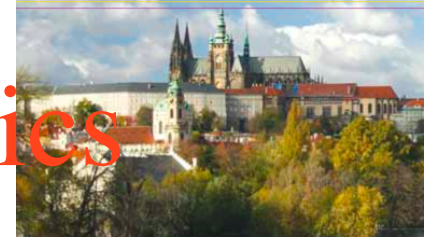

Pre-irrad

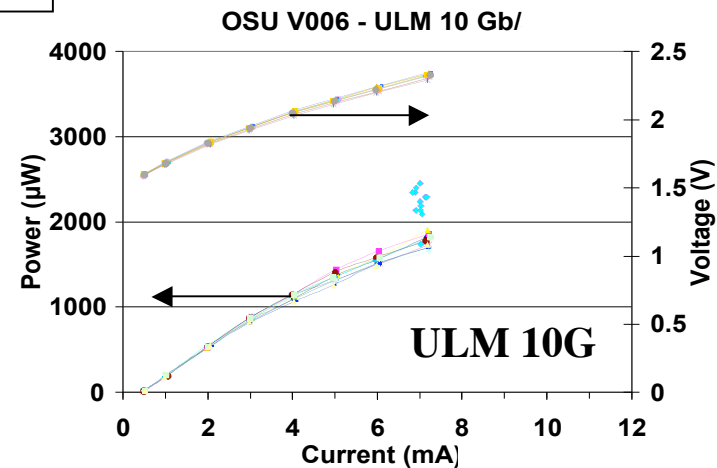
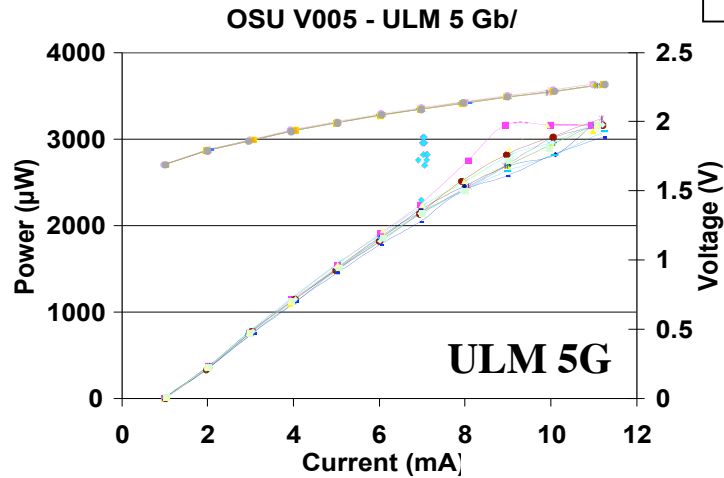

- ✘ ULM requires higher voltage to operate
- all arrays have very good optical power



VCSEL LIV Characteristics

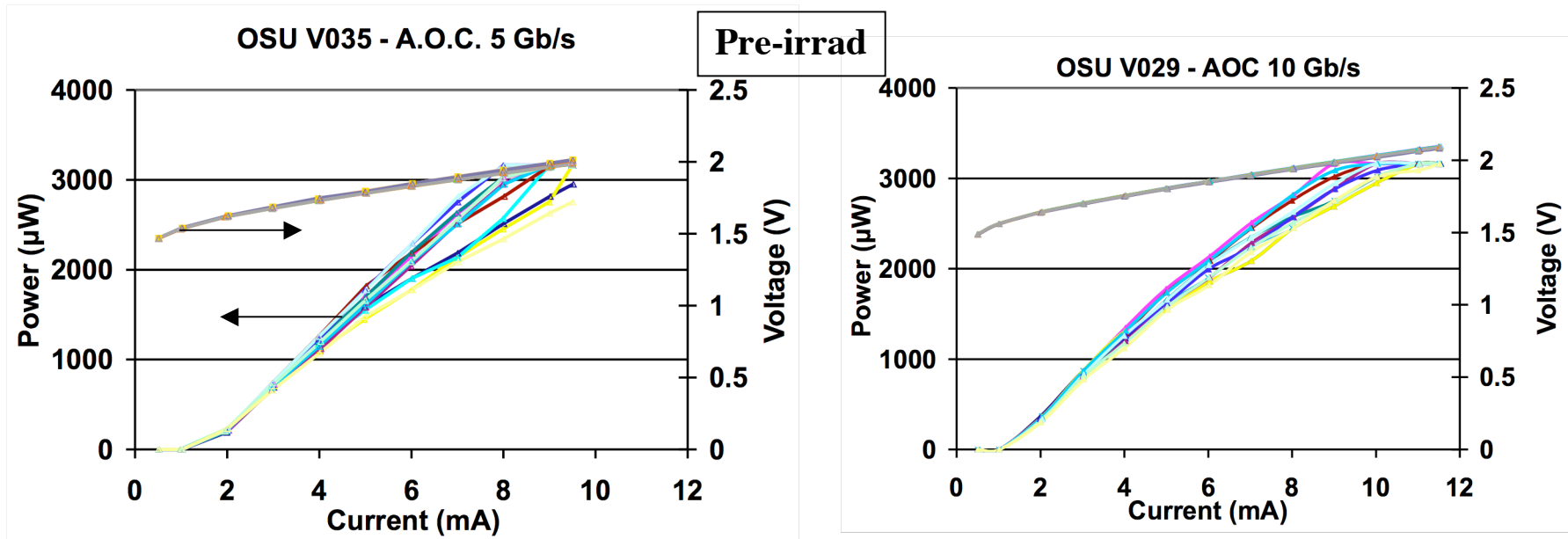
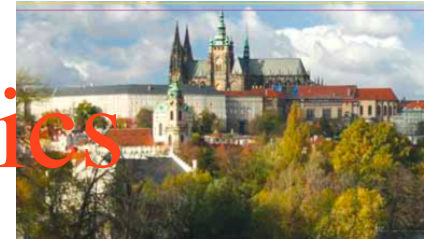

- both arrays have very good optical power



VCSEL Power vs Dosage

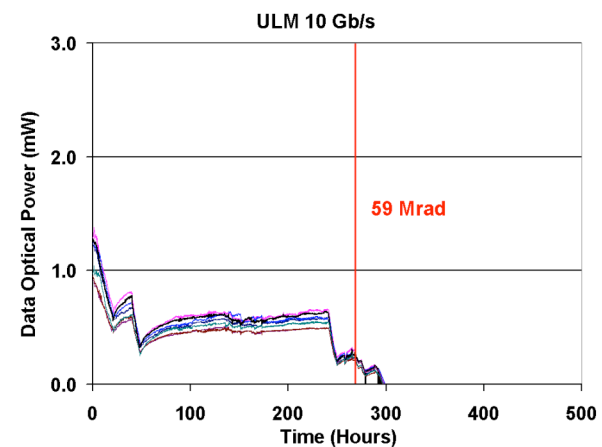
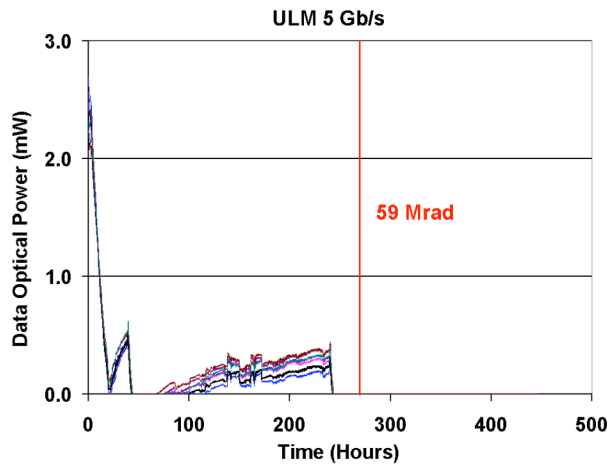
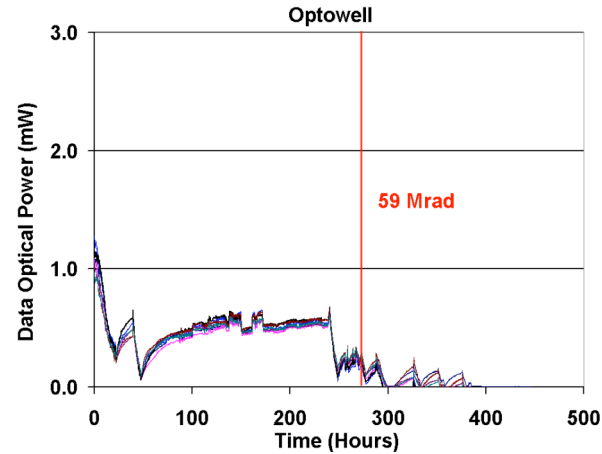
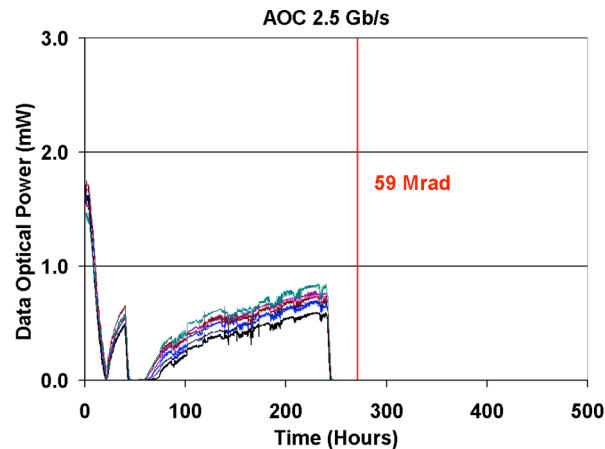
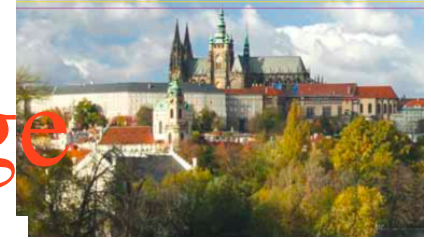

2006:
Two arrays each
(2 x 7 channels)

- Optowell & ULM (10 Gb/s) might survive to SLHC dosage
- more VCSELs might survive with lower intensity/more annealing



VCSEL Power vs Dosage

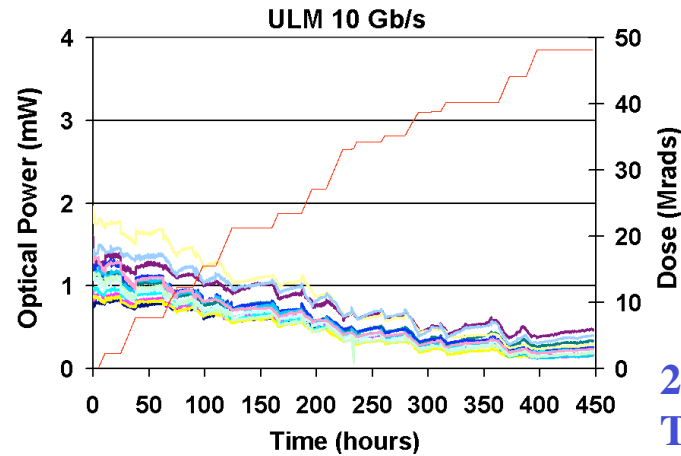
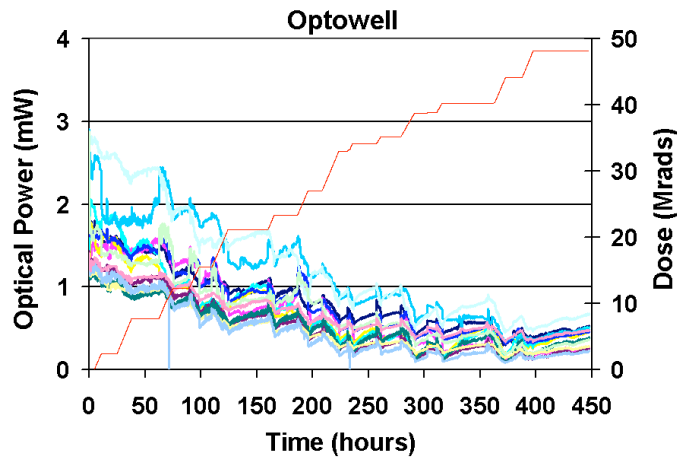
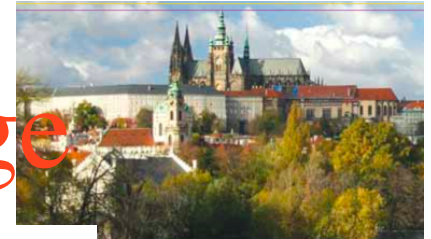

1st irradiation period

2007 preliminary
Two arrays each
(2 x 7 channels)

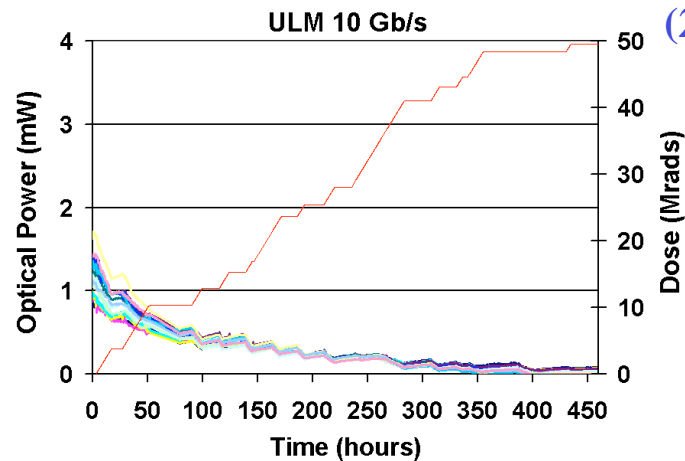
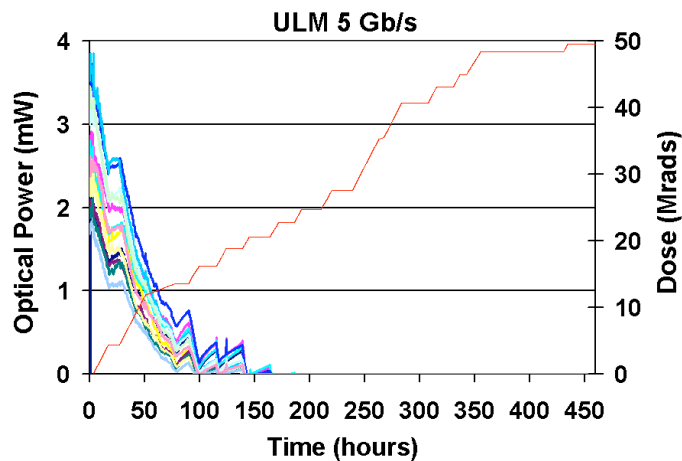

2nd irradiation period

- Optowell & ULM (10 Gb/s) might survive to SLHC dosage



VCSEL Power vs Dosage

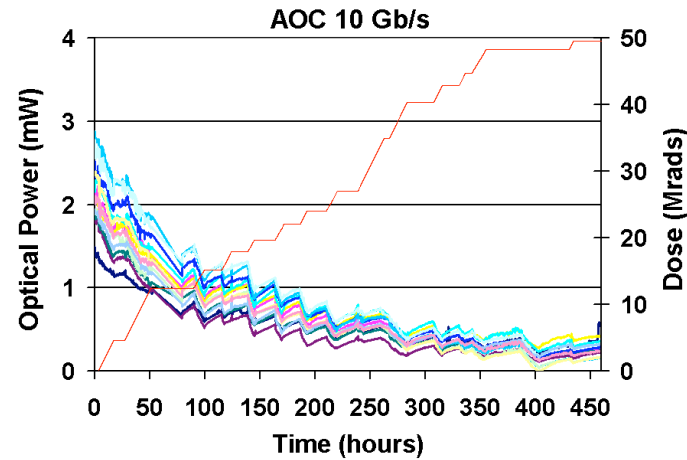
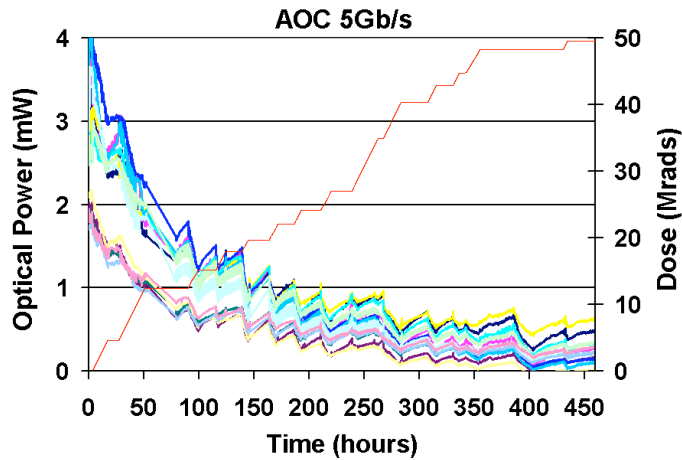
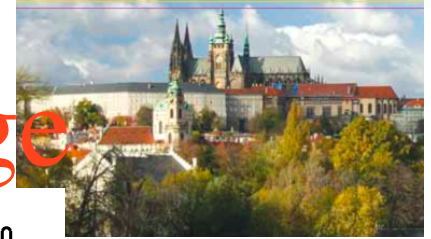

1st irradiation period

2007 preliminary
Two arrays each
(2 x 7 channels)

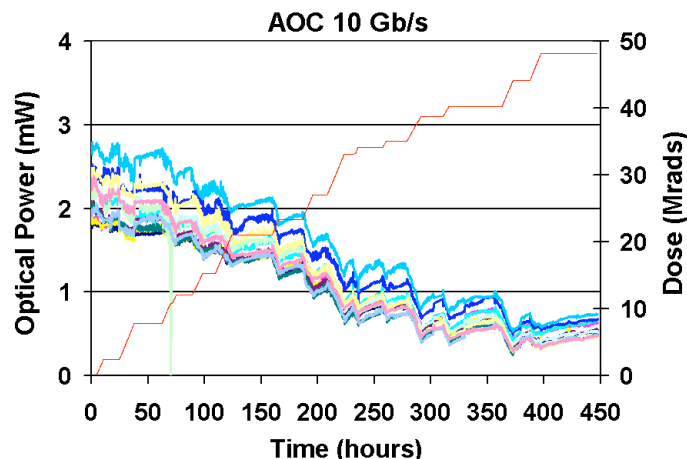
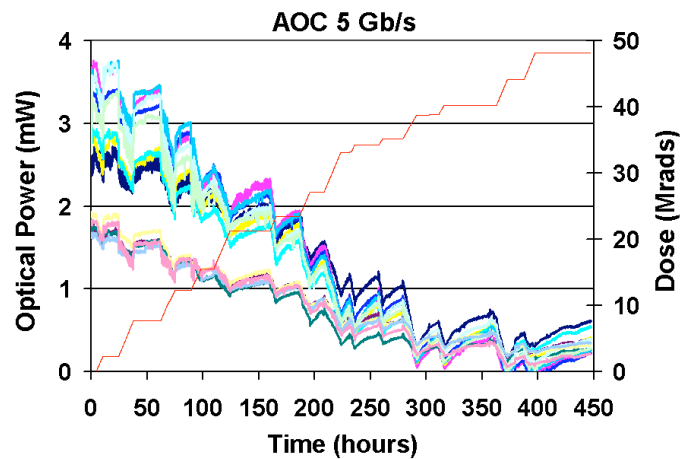

2nd irradiation period

- AOC (5 & 10 Gb/s) might survive to SLHC dosage
- need further analysis after radiation cool down...



Opto-Pack Development

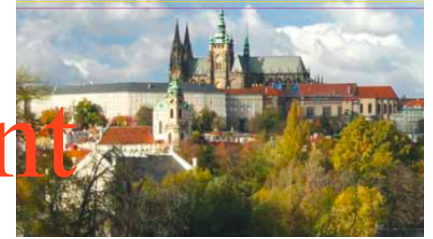

- current pixel detector uses Taiwan optical packages
 - ☹ VCSEL mounted on PCB with poor heat conduction
 - ☹ micro soldering of 250 μm leads is difficult
- Ohio State develops new opto-pack for SLHC
 - uses BeO base with 3D traces for efficient heat removal
 - wire bond to driver/receiver chip

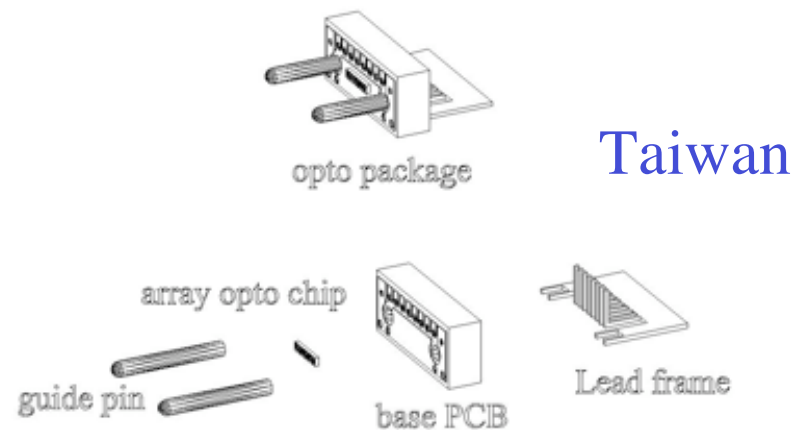
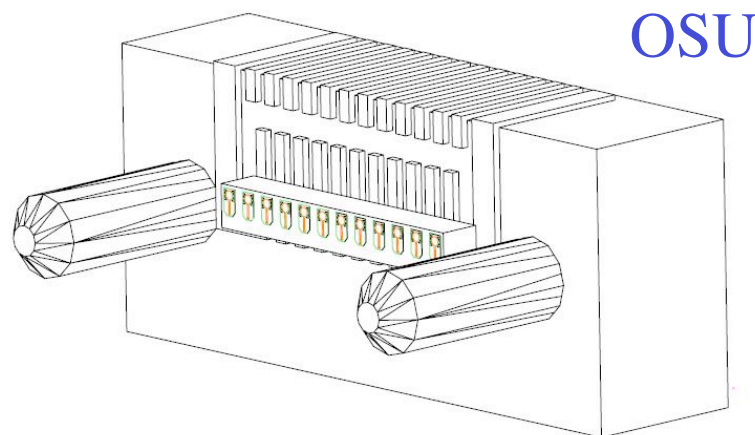



Results on Opto-Packs

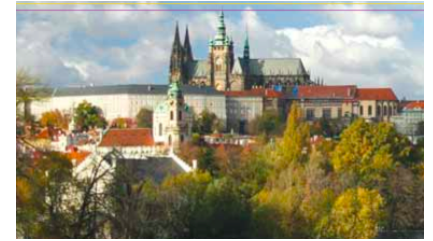

- 35 VCSEL & 6 PIN opto-packs have been fabricated
 - ◆ all VCSEL opto-packs except one have good coupled power
- ⇒ principle of new opto-pack has been demonstrated

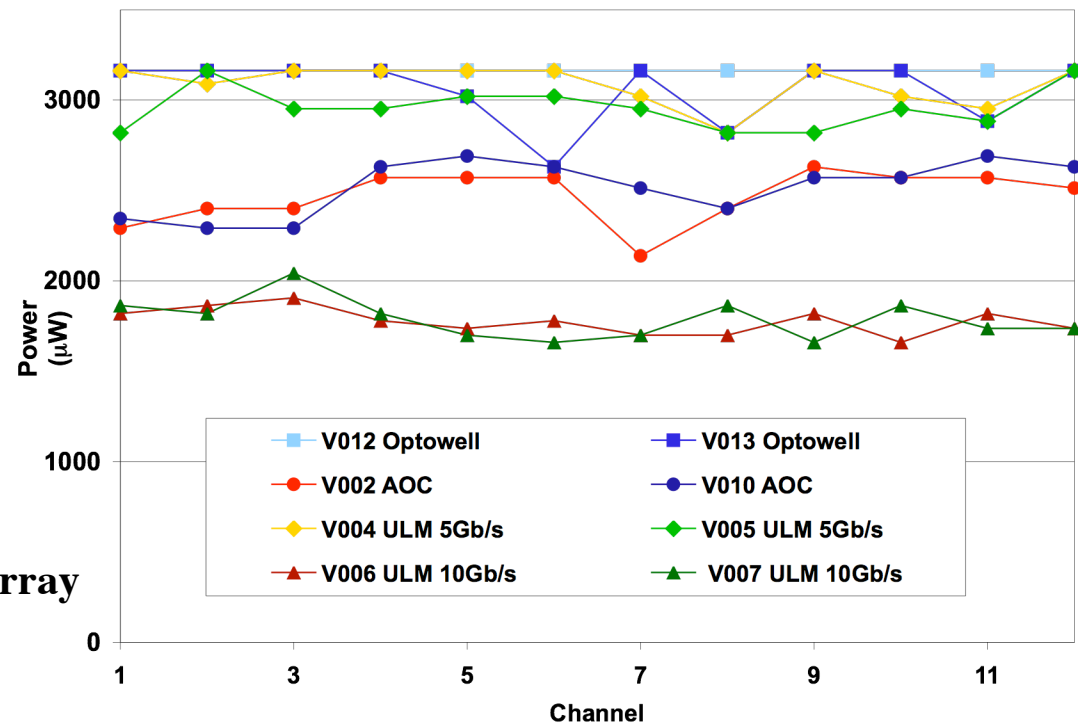
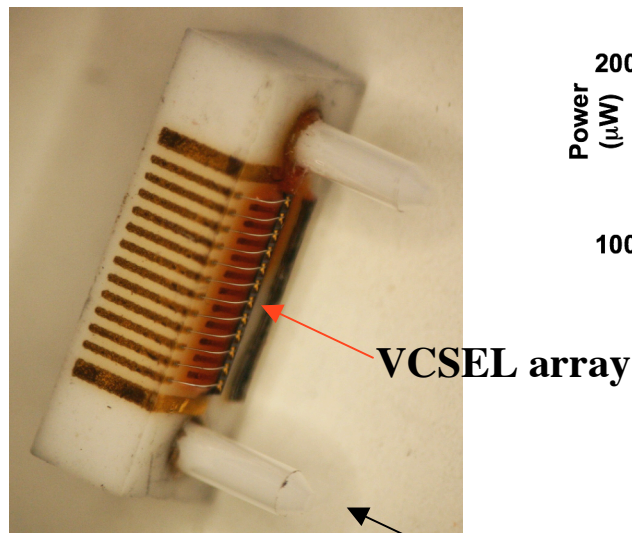
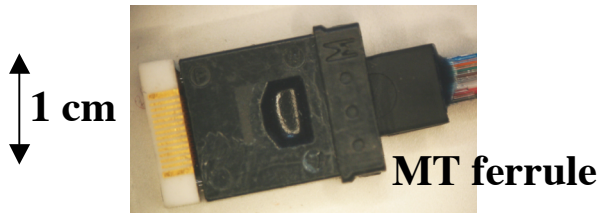



Summary



- micro twisted-pair cable of current ATLAS pixel detector can be used for transmission up to 1 Gb/s
- fusion spliced SIMM/GRIN fiber can transmit up to 2 Gb/s
- Si PIN responsivity decreases by 65% after SLHC dosage
- VCSEL from 3 vendors might survive to SLHC dosage
- ⇒ current opto-link architecture satisfies SLHC requirements
- compact MT-style opto-pack based on BeO has been developed